



TIPPER TIE®

A **DOVER** INDUSTRIES COMPANY

P.O. BOX 866 LUFKIN ROAD
APEX, N.C. USA 27502-0866
(919) 362-8811 or 1-800-331-2905
FAX: (919) 362-8667

Clipper VAC MODEL CVW Machine Manual

Manual No. 80-1409
Revision No. 03
01/08/01

Table of Contents

Chapter 1: Machine Description and Specifications

1.1 Description	4
1.2 Applications	4
1.3 Machine specifications	5

Chapter 2: Safety Instructions

2.1 International Safety signs	6-7
2.2 Safety Instructions	8-9
2.3 Danger Areas	10

Chapter 3: Delivery and Inspection

3.1 Delivery and inspection	11
3.2 Unpacking equipment	11

Chapter 4: Air Connections

4.1 Installation of Main air supply	12
4.2 Adjustment and lubrication	12-13
4.3 Air Regulator Assembly	14

Chapter 5: Operating Instructions

5.1 Air Adjustment	15
5.2 Vacuum pump	15
5.2.1 Electrical requirements (vacuum pump)	15
5.2.2 Lubrication system (vacuum pump)	15

Chapter 6: Operating procedure

6.1 Vacuum nozzle operation	16-18
6.2 Clipper operation	16
6.3 Unit recycles	16

Chapter 7: Maintenance

7.1 Cleaning	19
7.2 Cleaning vacuum lines and waste storage tank	20-21
7.3 US Department of Agriculture guidelines	22-23
7.4 General Maintenance check list	24
7.5 Trouble shooting guide	25

Chapter 8: Spare Parts List

8.1 Recommended Spare Parts	26
8.2 Loose Parts List	26

Chapter 9: Assembly drawings	26
---	----

Tipper Tie Warranty:

- (a) Tipper Tie warrants to Purchaser that equipment manufactured by Tipper Tie and sold to Purchaser hereunder shall be free from defects in material and workmanship under normal use and service for the earlier of (i) a period of one year from the date of installation of the equipment, or (ii) the period ending when the equipment has run the number of Machine Cycles as specified on Addendum A attached hereto for the particular model of equipment purchased by Purchaser (the "Warranty Period"). Any claim made under this warranty must be presented, in writing, to Tipper Tie during the Warranty Period. Tipper Tie makes no warranties as to any equipment or accessories not manufactured by Tipper Tie, and Purchaser shall be limited only to the warranties, if any, provided by the manufacturer of such equipment or accessories.
- (b) Tipper Tie's sole responsibility for any breach of the warranty contained herein shall be to repair or replace at Tipper Tie's option and, at Tipper Tie's sole cost and within a commercially reasonable period following receipt of a claim from Purchaser within the Warranty Period, items, components and/or parts not conforming to such warranty, f.o.b. Apex, North Carolina. All parts replaced by Tipper Tie shall become the property of Tipper Tie.
- (c) The foregoing warranty shall not apply to, nor shall Tipper Tie be responsible for, damages resulting from normal or excessive wear and tear of the equipment or component parts thereof (such component parts to include, but not be limited to, punches, dies, knife blades, skin brakes, conveyor belts and other parts which by their nature and as a result of normal equipment operation wear out and must be replaced), improper operation, operating under improper conditions or defects resulting from faulty installation which has not been carried out by Tipper Tie. The warranty becomes immediately void in every case where repairs, modifications or alterations are carried out by the Purchaser or by third parties, without the prior written consent of Tipper Tie. The warranty also does not cover any damages caused by insufficient, incorrect or forceful operation of the equipment, failure to observe the operating instructions, overloading, the use of materials, consumables or accessories not manufactured by Tipper Tie or specifically approved in writing by Tipper Tie for use with the equipment, chemical or electrolytic action, the use of spare parts from an outside source, or any event of force majeure.
- (d) **THERE ARE NO WARRANTIES, EXPRESS OR IMPLIED, GIVEN BY TIPPER TIE EXCEPT AS SET FORTH IN THIS WARRANTY SECTION, AND TIPPER TIE EXPRESSLY DISCLAIMS ALL OTHER WARRANTIES, INCLUDING BUT NOT LIMITED TO ANY AND ALL IMPLIED WARRANTIES OF MERCHANTABILITY OR FITNESS FOR A PARTICULAR PURPOSE. UNDER NO CIRCUMSTANCES SHALL TIPPER TIE'S LIABILITY HEREUNDER EXTEND TO OR INCLUDE LIABILITY FOR ANY SPECIAL, CONSEQUENTIAL, INCIDENTAL, PUNITIVE OR OTHER DAMAGES OF ANY KIND OR CHARACTER. THE WARRANTIES PROVIDED HEREIN MAY NOT BE ALTERED, EXTENDED OR VARIED EXCEPT BY A WRITTEN INSTRUMENT SIGNED BY TIPPER TIE AND PURCHASER.**

ADDENDUM A

<u>Model Number</u>	<u>Cycles/minute</u>	<u>Machine Cycles</u>
RS4202M	14	1,400,000
SAMIIIIE	25	2,500,000
TB-15	15	1,500,000
TCM 2250, pump	8	800,000
TCM 2250, breech	5	500,000
PTM	17	1,700,000
PTRFMx, normal	30	3,000,000
PTRFMx, high speed	45	4,500,000
TC4353	15	1,500,000
Alpina DKF 18/15	80	8,000,000
Alpina DKF 15/12	150	15,000,000
	<u>Hours/day</u>	<u>Hour/year</u>
Rota-Clip	8	2000

Chapter 1: Machine Description and Specifications

1.1 Description

The Clipper VAC, MODEL CVW, is a vacuum operated packaging machine designed to draw a vacuum and create a seal using **TIPPER TIE** clip closure technology. The machine is designed to accommodate either one of these clippers to meet different packaging requirements.

AZ2100LM Model Clipper, using Z200 Series clips:

Z201 Clips cover 3 MIL bags, 6"-12" flat width

Z211 clips cover 3 MIL bags, 7"-16" flat width

AZ4100LM Model Clipper, using Z400 Series clips:

Z401 clips cover 3 MIL BAGS, 8"-18" flat width

Z411 clips cover 3 MIL BAGS, 10"-23" flat width

For each machine cycle the machine will:

- *Draw a vacuum on package*
- *Gather the bag neck*
- *Apply a secure vacuum tight clip*
- *Trim excess material from bag tail*

Machine features:

- *Simplified valve design for faster cycling and greater reliability.*
- *Maximum operator safety, machine completely guarded.*
- *Two different clippers are available to meet most packaging needs.*

1.2 Applications

This machine is ideal for packaging a variety of products requiring a vacuum tight seal. products include, red meats, processed meats, smoked meats, cook-ins, cheeses, poultry etc.

1.3 Machine Specifications

Air consumption: 12 CFM @ 80 PSI
(340 liters @ 5,5 Bar)
at 20 cycles per minute

Electrical requirements:

USA

110 Volts, 50/60 Hz

6 Amps (full load)

European Union

220 Volts, 50 Hz

3.2 Amps (full load)

Shipping Weight::

250 Lbs (113,4 Kg.)

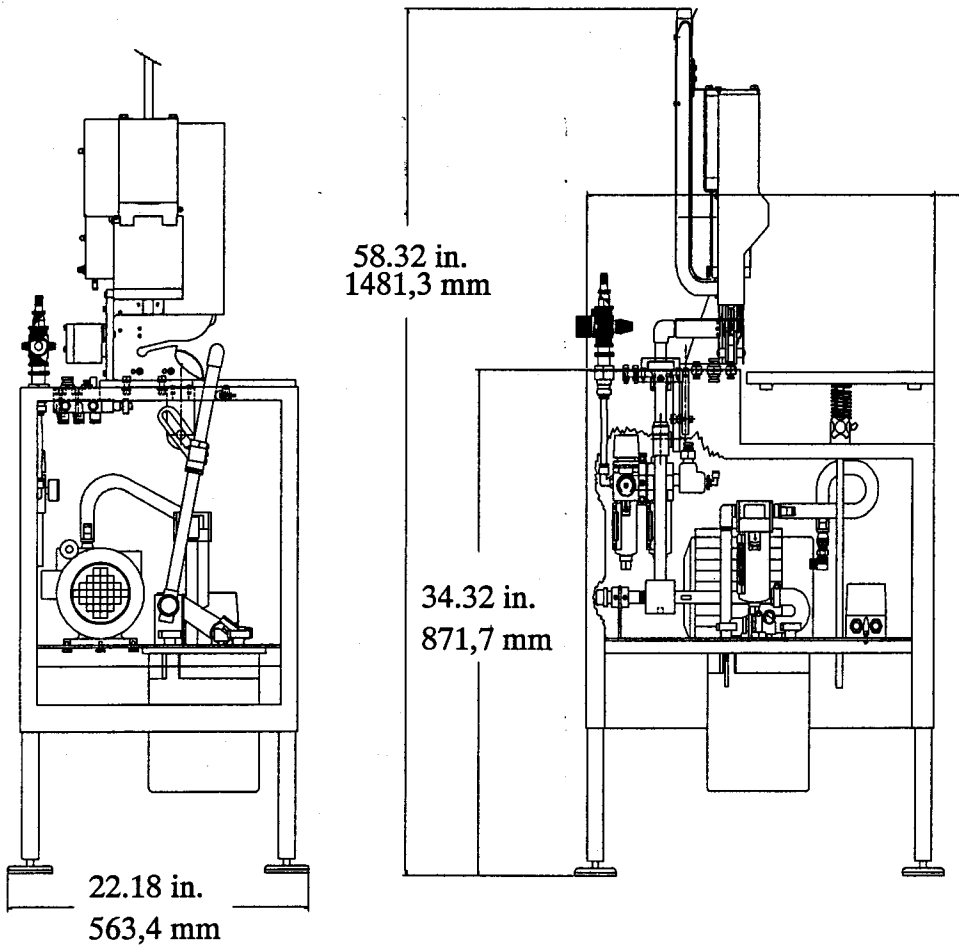

Chapter 2: Safety Instructions

2.1 International Safety Signs

INTERNATIONAL SAFETY SIGNS USED TO COMMUNICATE HAZARD INFORMATION USED WITH APPROPRIATE MACHINE FUNCTIONS

- THE YELLOW TRIANGLE SIGNS WARN OF EXISTING HAZARDOUS CONDITIONS
- THE BLUE CIRCULAR SIGNS DEFINE MANDATORY ACTIONS REQUIRED

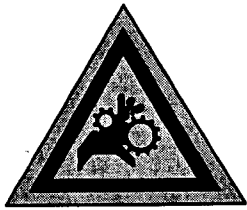

WARNING: DANGER OF CRUSHING

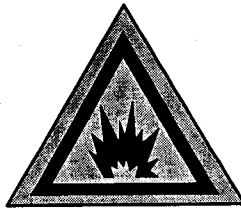

WARNING: EXPLOSIVE ATMOSPHERE

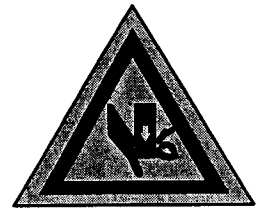

WARNING: KEEP HANDS AWAY FROM PINCH AREA

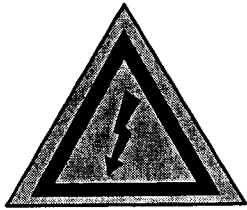

WARNING: DANGEROUS ELECTRICAL CURRENT

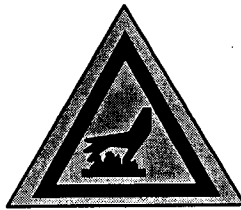

WARNING: HOT SURFACE



WARNING: KEEP HANDS AWAY FROM KNIFE AREA

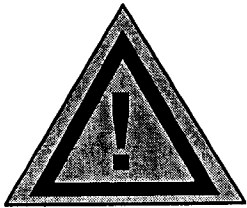

WARNING:



INSERT SAFETY LOCKOUT



CONSULT SERVICE MANUAL



ELECTRICAL LOCKOUT REQUIRED

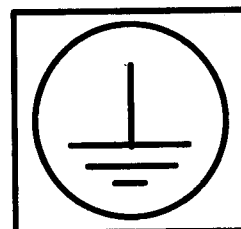

PROTECTIVE EARTH GROUND

2.1 International Safety Signs continued:

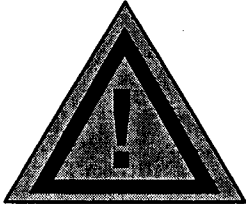

WARNING:

When using this machine, all operating instructions, safety instructions and precautions must be followed and strictly adhered!

Do not attempt to install, setup or operate this machine before you have read and understood this manual and any accompanying supplier's manuals.



Follow all warnings and safety instructions in this manual. Failure to comply with safety instructions could result in serious injury.

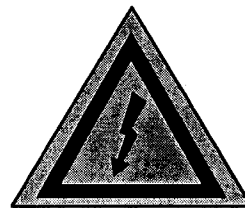
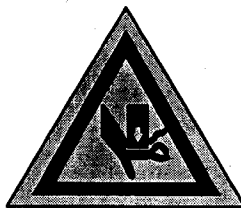

2.2 Safety Instructions

With the use of this machine, the following safety precautions must be obeyed:

- Before installing and first operating the machine, this manual must be read and understood. Follow all operating and safety instructions and exercise extreme care.
- This machine must be installed securely, and permanently attached to a solid surface before starting and operating.
- This machine must be operated only by trained personnel. Training must be repeated at regular intervals.
- Safety devices must be checked each day to ensure proper operation. Safety features should be examined once each year by experts.
- All guards, protective covers and shields must be in place before operating the machine. Do not modify, remove, disable or bypass the guards. Operating this machine with guards, covers and shields removed could result in serious injury. **Never operate this machine without safety devices.**
- **The maximum working pressure for this machine is 80 PSI, (5,5 BARS)**
Air pressure greater than this could cause an explosive rupture in any of the air lines or pneumatic components. Failure to adhere to this caution could result in personal injury or damage to the machine.
- Keep hands and fingers clear of the punch, die and knife areas at all times. Never touch these areas while the machine is in operation. Do not allow fingers, hands, jewelry or clothes around moving parts during operation of this machine.

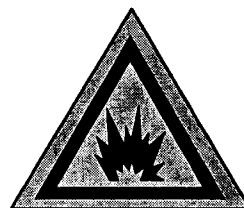
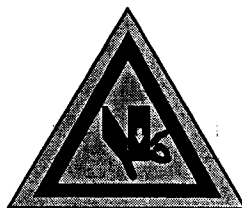

2.2 Safety Instructions continued:

- Immediately report any malfunction to the person in charge
- Stop machine to correct malfunctions.
- Disconnect air supply prior to servicing or moving the machine. The main air supply line must be disconnected from the machine before performing any service operation or maintenance.
- When this machine is not in operation, the air supply must be disconnected at the plant / regulator junction or at the quick disconnect on the machine. Failure to disconnect the air supply from this machine creates serious risk of injury. To prevent unauthorized personnel from operating this machine, rotate the red emergency stop valve 1/4 turn clockwise. Attach a padlock through the holes.
- Electrical operated devices, (motor, vacuum pumps etc.) must be turned-OFF and locked out before servicing. The ON/OFF switch must be turned off from inside of the cabinet. Be aware of the danger of Electrical Shock! Failure to disconnect creates serious risk of injury.
- When moving the machine, keep hands and fingers clear of punch, die and knife areas.
- Use only original spare parts and accessories.
- If the machine is sold, the manual must be supplied to the new owner.

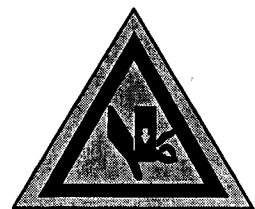
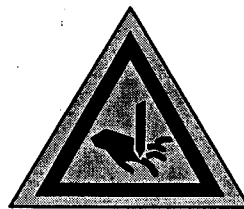

2.3 Danger areas

Warning:
Keep hands and fingers clear of die, punch, and knife areas.

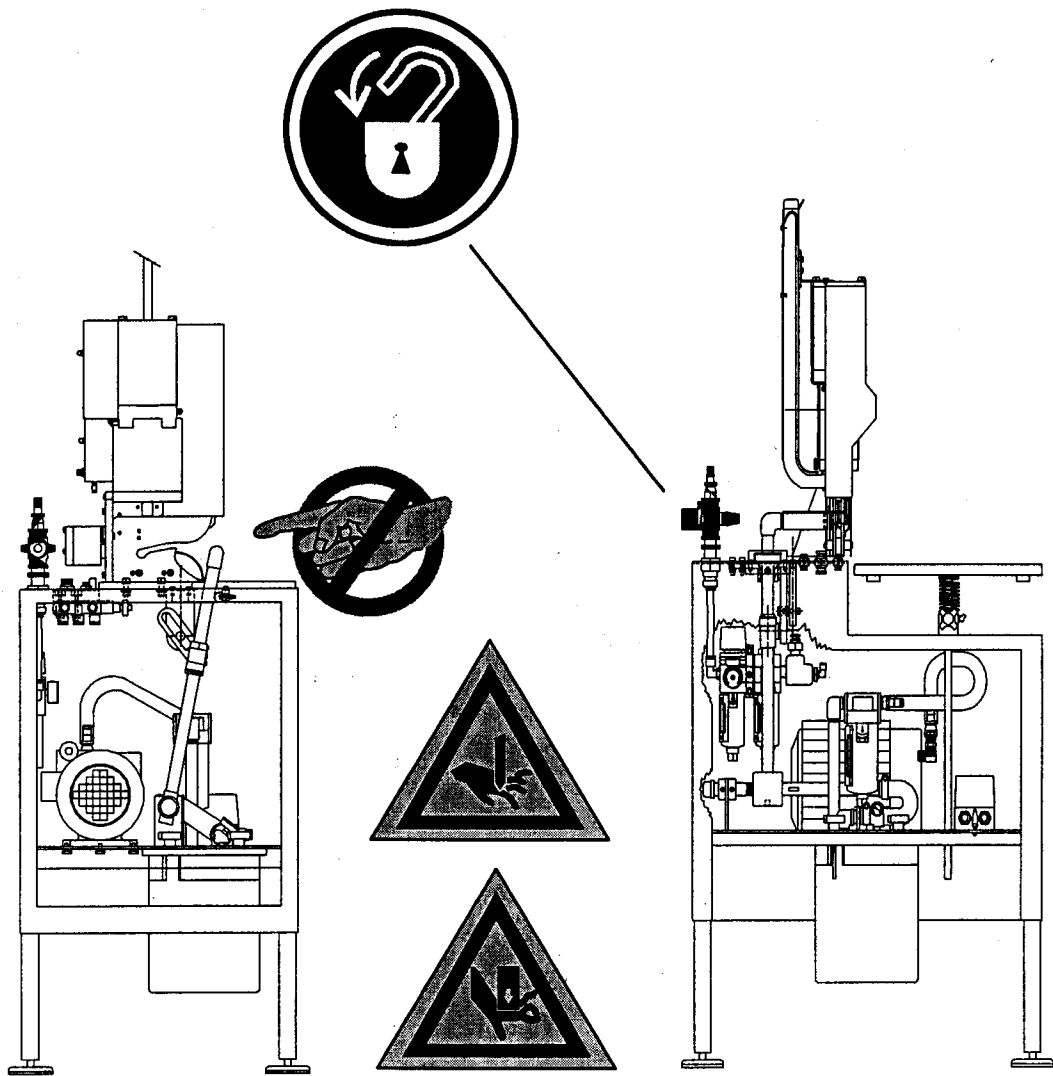

Chapter 3: Delivery and Inspection

3.1 Delivery

Upon delivery, inspect the shipping container and equipment for damages due to shipping and handling. If damage is found or suspected, contact the shipping agent immediately. In order that the carrier may have an opportunity to inspect goods and thereby properly verify claims, any loss or damage discovered after delivery should be reported to the agent of the delivering line immediately or within 15 days after receipt of goods.

In many instances, the original container is not opened and the contents not examined before reshipment to final destination. Therefore, under (SUBPART C: CLAIMS FOR LOSS OR DAMAGE: SECTION 1226.200 NATIONAL MOTOR FRIGHT CLASSIFICATION), 9 months are allowed for filing claims for loss or damages.

The shipping agent or carrier will help you in processing your claim. Remember to report all suspected damages immediately. If additional assistance is required, TIPPER TIE will gladly help in settling your claim. However, first contact the carrier or his agent involved.

WITH ALL CORRESPONDENCE, INCLUDE THE FOLLOWING:

- * Original bill of lading or copy thereof. *
- * Vendor invoice, or certified copy, when claim is based on weight or valuation of shipment has been improperly described.
- * Catalog pages or product information.
- * Original packing slip or receiving reports.
 - * or copy of electronic bill of lading manifest.

3.2 Unpacking Equipment

For ease of shipping, partial disassembly of the machine sometimes is necessary. Check the shipping list and loose parts list to ensure that all items have been received. Do not discard packing materials until machine is assembled and operation. notify **Tipper Tie** immediately if any component is missing or if additional assistance is required.

Refer to the installation and operating instructions before starting to operate the equipment. Add all required oils and fluids, and make all machine adjustments as instructed before starting machine. Failure to do so may result in equipment damage or personal injury, and voids product warranty.

Chapter 4: Air Connections

4.1 Installation of Main Air Supply

Note:

For installation within the European Union, Plant air supply must not be above 6 BAR (87 PSI).

- Clipper working pressure is between 3-6 BAR (43.5-87 PSI)
- Recommended air pressure setting is 5,5 BAR (80 PSI)
- Before operating, check air line connections as set at the factory. If lines have become disconnected, reassemble as shown per the Pneumatic schematic.
- Air pressure can be regulated from the air regulator assembly. The air regulator assembly consists of filter, regulator, and oiler. Please note incoming air direction. (plant air flow). The air regulator unit is located inside the cabinet, under the **QUICK-DISCONNECT AND RED LOCK-OUT VALVE**, mounted on the outside top surface of the machine. The cabinet doors can be easily opened and removed for servicing. Always replace and close cabinet doors before operating.

4.2 Adjustment and lubrication

Lubricator oil flow is adjusted by turning the front needle valve. By turning counter-clockwise, the oil drop rate will increase. Turning clockwise will decrease oil flow.

To regulate air pressure, pull the locking type adjustment knob away from the body of the regulator until the orange band is visible. Rotate knob to regulate air pressure (clockwise to increase pressure / counter-clockwise to decrease the pressure). When adjustment is complete, push the knob back to the body of the regulator.

WARNING:

DO NOT SET AIR PRESSURE ABOVE 6,8 BAR (100 PSI), CHECK THE AIR PRESSURE GAUGE!! SERIOUS INJURY AND DAMAGE WILL RESULT IF THE MACHINE IS OPERATED ABOVE THIS AIR PRESSURE.

4.2 continued:

- Change filter elements after one (1) year of service or when the air pressure drops to **1kg/cm sq. [1.03 BAR (15PSI)]**.
- Recommended lubrication: **ISO VG32**

WARNING:

DO NOT USE POLYCARBONATE BOWL ON FILTER / LUBRICATOR / REGULATOR

The polycarbonate bowls may be damaged and possibly fail if exposed to synthetic oils, thinner solvents, trichlorethylene, kerosene and other aromatic hydrocarbons. Therefore a **metal bowl** rather than polycarbonate is recommended.

WARNING:

The lubricator cannot be refilled under pressure. Always **shut off** the air pressure supply and purge pressure from the system, and lock-out before refilling with lubricating fluids.

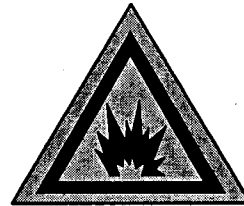

4.3 Air Regulator Assembly

Recommended setting is 80 PSI (5,5 BAR)

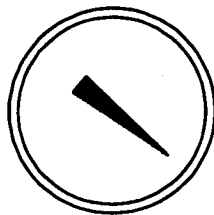
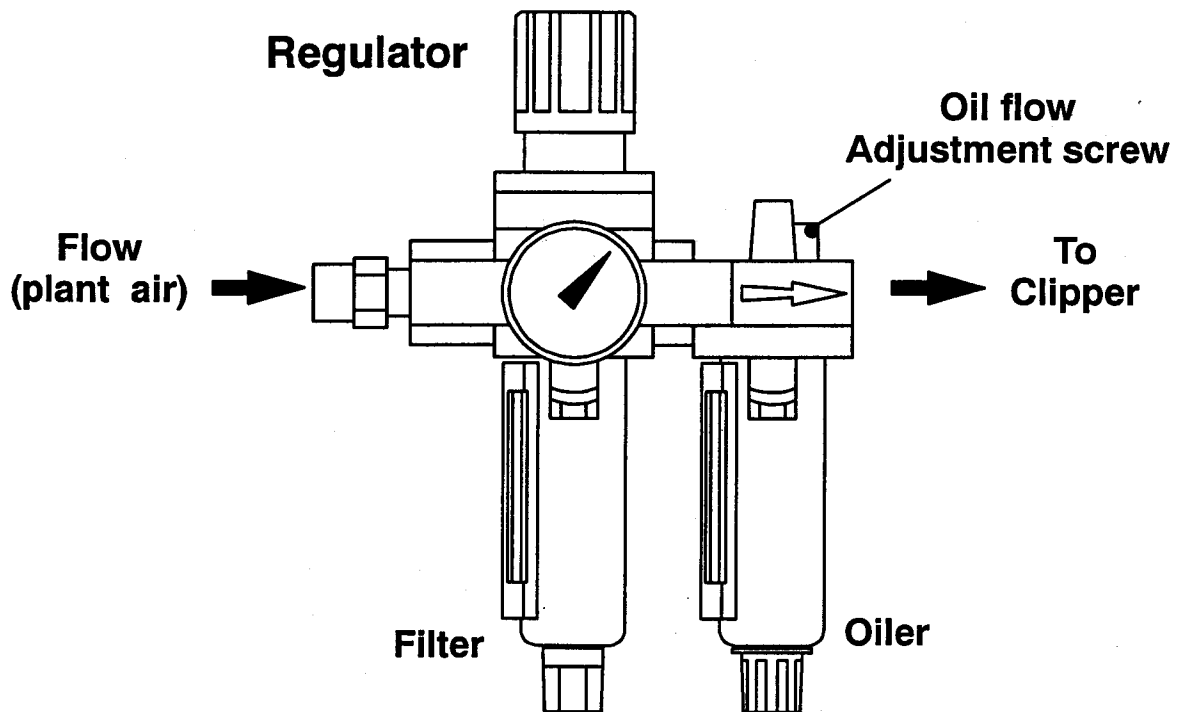

**Working Pressure is between
43.5-87 PSI, (3-6 BAR)**

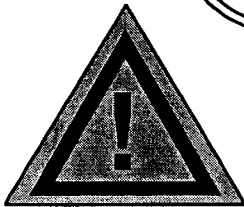

**Warning:
Do not set air pressure
above 100 PSI, (6,9 BAR)**

Chapter 5: Operating instructions

5.1 Air adjustment

The air regulating unit is located inside the **CLIPPER VAC** cabinet, under the **RED LOCK-OUT VALVE AND QUICK-DISCONNECT JUNCTION**.

- Connect the factory air coupling onto the machine at this junction.
- With air regulator **TURNED-OFF**, inside cabinet, slowly **TURN-ON** the **RED LOCK-OUT VALVE**.
- Adjust the air regulator to **5,5 BAR (80 PSI)** as outlined in **CHAPTER 4**.
- Listen for any air leaks around machine before continuing, correct as required before starting machine.

5.2 Vacuum pump

The **TIPPER TIE CLIPPER VAC** uses a single stage rotary vacuum pump.

5.2.1 Electrical requirements (vacuum pump)

WITHIN THE USA:

VOLTS:	110
Hz	50/60
HP/kw	.5/.37
Amps (full load)	6
RPM	3240

WITHIN THE EUROPEAN COMMUNITY:

VOLTS:	220
Hz	50
HP/kw	.5/.37
Amps (full load)	3.2
RPM	3240

All electrical connections should be made by qualified, competent electricians in accordance with all local and national codes.

5.2.2 Lubrication system (vacuum pump)

Before operating the machine, check the operating oils. For ease of shipping, the vacuum pump may need the addition of operating oils. Check for correct oil level and the oil filling procedure. After unpacking inspect the oil sight glass for correct oil level before starting machine.

Upon starting vacuum pump, check for vacuum leaks around all hose connections. Refer to pump operators manual for additional information and trouble shooting guide.

Chapter 6 Operating procedure

6.1 Vacuum nozzle operation

DANGER! While operating machine, never place fingers near or through the slot in clipping area, or hands into or around the gate area. **SERIOUS INJURY MAY RESULT!**
DO NOT OPERATE WITH GUARDS REMOVED!

- Place neck of the product to be sealed around the vacuum nozzle.
- **MANUALLY MOVE** the vacuum tube nozzle assembly forward. As the nozzle unit moves, the activating lever under the cabinet opens the **BALL VALVE**, connected to the vacuum pump. The nozzle assembly starts to draw a vacuum on the package, preparing it for clipping and sealing. (The ball valve is normally closed as the vacuum pump operates.)
- Continue to move the nozzle assembly forward until end of stroke, (vacuum continues to be drawn on package).
- As the product moves forward with the nozzle, the bag tail slides into the clipper gate assembly.
- At the maximum forward stroke, the **CLIPPER GATE VALVE**, under the cabinet is activated, firing the clipper thru its cycle.

6.2 Clipper operation

When the **GATE VALVE IS CLOSED**, the gate cylinder pressurizes, closing the front gate. The punch drives down, taking a clip from the magazine rail, continuing to the clip forming die, completing the closure. After the package is vacuum sealed and clipped, the trimming knife from the clipper extends to cut-off extra bag tail. (For additional information and clipper servicing refer to the clipper manual)

6.3 Unit recycles

When the nozzle assembly is manually returned to **HOME POSITION**, the clipper resets. **KNIFE RETRACTS, GATE OPENS, CLIPPER PUNCH RETRACTS.** and the **VACUUM VALVE CLOSES.** The unit is ready for another packaging cycle.

Chapter 6

6.1 Vacuum nozzle operation continued:

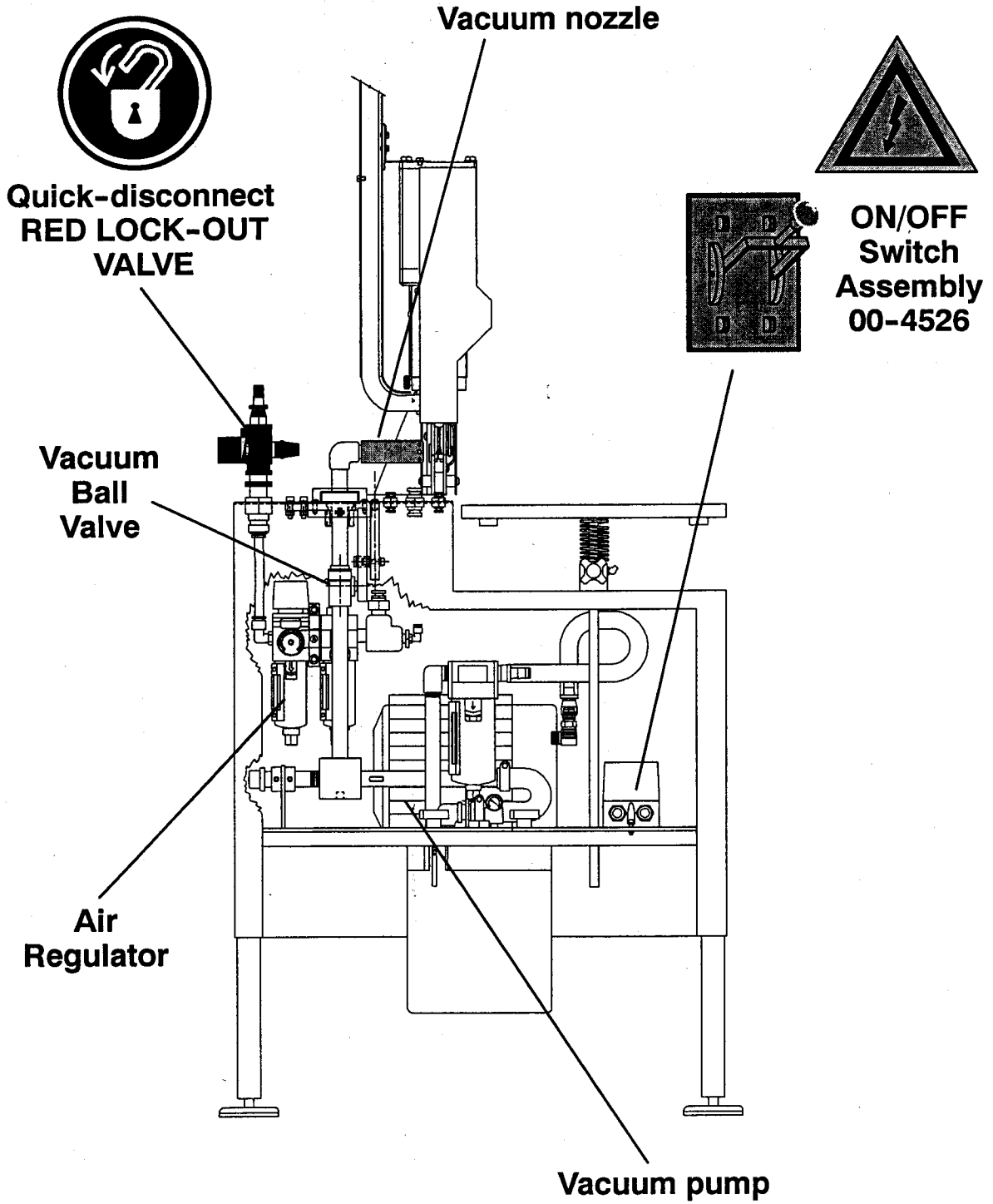

Chapter 6

6.1 Vacuum nozzle operation continued:

DANGER AREAS:

While operating machine never place fingers near or through the slot in clipping area, or hands into or around the gate area. serious injury may result!

NEVER
OPERATE
WITH
GUARDS
REMOVED!

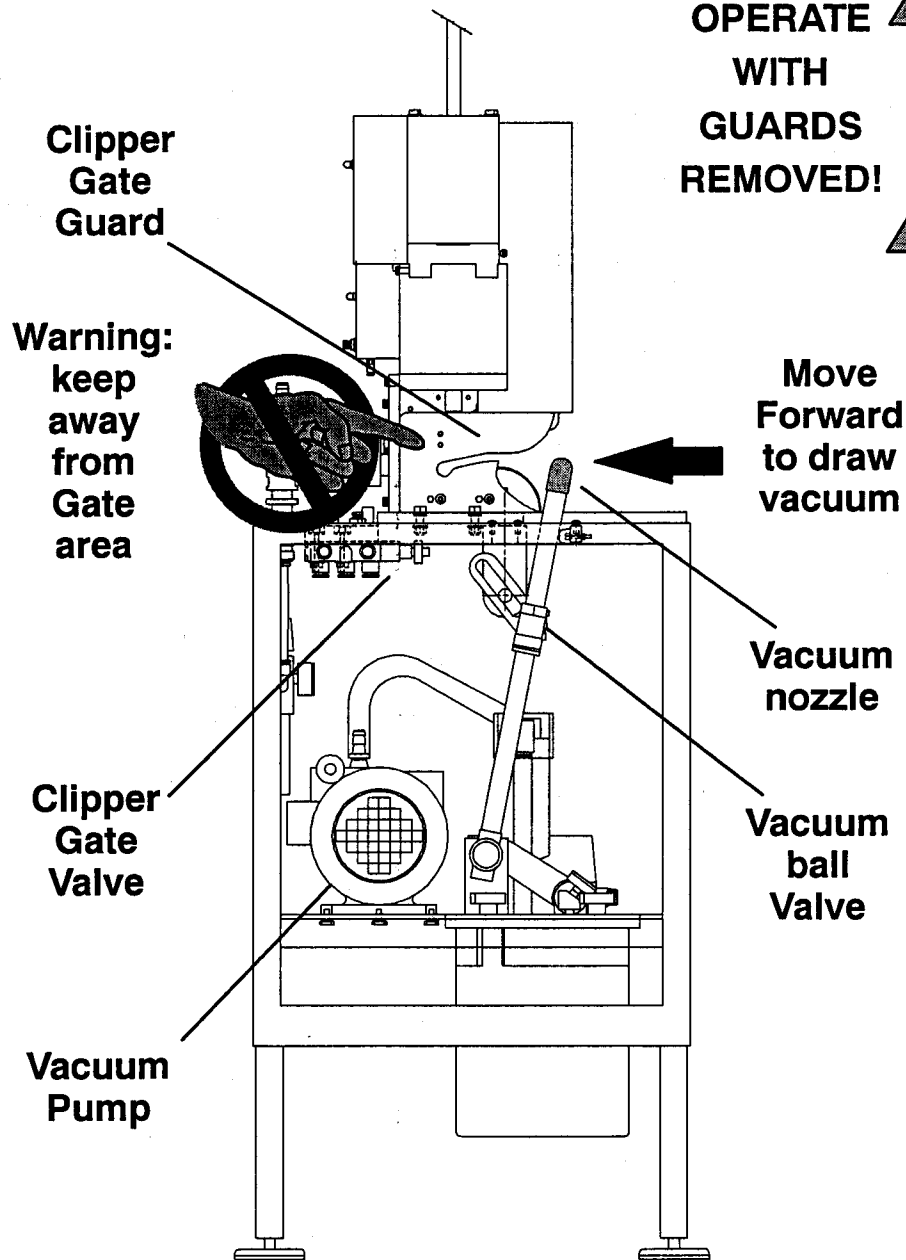
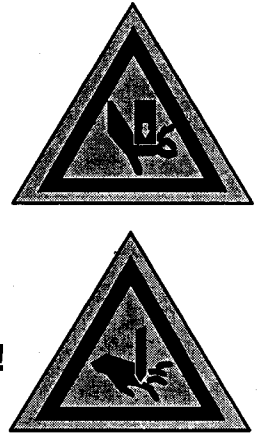

Chapter 7: Maintenance

7.1 Cleaning

After use of machine, the clipper must be cleaned to remove all residues (food products) from the throat, punch, knife and die areas, (*food contact zone*). Also check all other machine surfaces and surrounding work station for material residues or contamination. All surfaces must be cleaned using the recommended materials and procedures as outlined by the U.S. Department of Agriculture Food and Inspection Service Handbook No. 562. A copy of Part 5, Section 5.1, Titled: Cleaning Compounds: is included with this manual. Cleaning product approval, in writing is required, as outlined in the copy provided.

Remember, before cleaning, ensure that the air and electrical supply has been disconnected, and all lock-out procedures have been followed.

- Turn off factory air "**RED LOCK -OUT VALVE**" and disconnect the air lines from the cabinet with the "**Quick disconnect**" attached.
- Turn-off, disconnect and lock-out all air and electrical power

REMEMBER TO:

ALWAYS PROTECT ALL ELECTRICAL CONNECTIONS, PUMP MOTOR AND VACUUM LINES FROM WATER AND CLEANING FLUIDS!

- With the gate open remove all guards to expose all surfaces for cleaning.
- Clean all surfaces as outlined by the **U.S. DEPARTMENT OF AGRICULTURE HANDBOOK**.
- After cleaning, (FDA food contact approved) light mineral should be applied to the gate pivot areas. The internal moving parts are lubricated by the filter / regulator / lubricator.
- After cleaning and lubricating, reassemble all guards and check for safe function. Check for and tighten all loose connections and screws.
- While cleaning the Clipper VAC, inspect for worn or damaged components needing replacement. For replacement parts refer to the list of recommended spare parts, and assembly drawing. Before returning machine to operation check for burrs around die pocket of the clipper and remove.

7.2 Cleaning Vacuum lines and waste storage tank

Along with cleaning the outer surfaces of the machine, the vacuum system should be cleaned and purged daily.

The vacuum system and waste storage tank mounted in the machine cabinet must be cleaned using only the approved cleaning solutions as outlined by the US Department of Agriculture guide lines.

Follow all cleaning procedures described below

- Turn on the vacuum system, and move the vacuum nozzle forward until vacuum is applied. Attach a plastic bag containing approved cleaning solution to the vacuum nozzle, purge until the system is clean. Continue to flush out the vacuum system with clear potable water to remove all cleaning solution residues.
- Remove the waste tank, drain and clean. Continue flushing with clear potable water. Leave the tank unattached until the machine is ready to be used again. Let the waste tank air dry along with the vacuum system.
- When reattaching the waste storage tank and before using machine, always check the gasket seal, vacuum lines and vacuum nozzle for leakage.

7.2 continued:

Vacuum nozzle

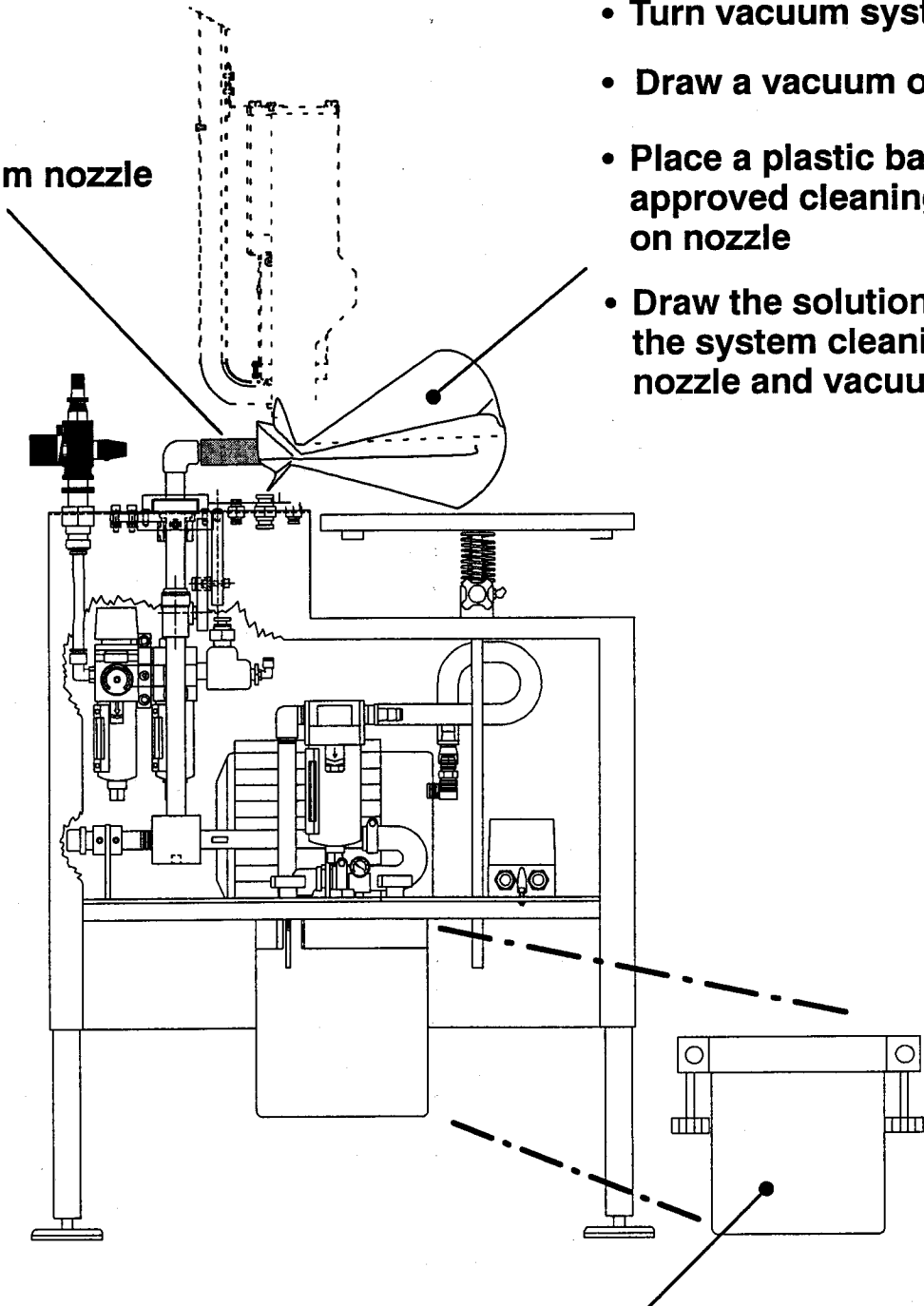

- Turn vacuum system on
- Draw a vacuum on system
- Place a plastic bag containing approved cleaning solution on nozzle
- Draw the solution through the system cleaning the nozzle and vacuum lines

After cleaning out vacuum lines, remove waste tank, empty and clean. Leave unattached and open to air dry until machine is ready to be used again.

7.3 U.S. Department of Agriculture Guidelines

**APPROVED CLEANING COMPOUNDS:
U.S. DEPARTMENT OF AGRICULTURE
FOOD SAFETY AND INSPECTION SERVICE
(REFERENCE AGRICULTURE HANDBOOK NO. 562)**

This publication is intended to assist in applying approved cleaning methods under the USDA meat and inspection program. Cleaning materials used must be in compliance with the USDA. Compliance with the requirements set forth in the publication does not, in itself constitute authorization. Users must submit application with the USDA for consideration of suitability of preparations and their safety for use as directed.

Submit requests for such evaluation to :

Compounds Evaluation Unit, CPS
Product Safety Branch
Food Ingredient Assessment Division, Science, FSQS
U.S. Department of Agriculture
Building 396, Room 300, Barc-East
Beltsville, MD 20705
Tel (301) 344-2566

**U.S. Department of Agriculture Food Safety and Inspection Service
Handbook No. 562 Part 5, Section 5.1 Cleaning Compound**

(A) GENERAL USE CRITERIA

- (1) Neutral or mildly alkaline preparations consisting of any combination of soaps, detergents, wetting agents, emulsifiers, solubilizers, and common inorganic builders may be used on any surface in and department
- (2) Strongly alkaline preparations (those containing in excess of 20 percent caustic soda or other ingredients with the equivalent causticity thereof) may be used only in soak tanks or with steam or mechanical cleaning devices in any department
- (3) Acidic preparations consisting of mineral acids, organic acids, or acidic salts may be used in any department for the removal of rust, corrosion, scale, or other deposits which are not readily removed by alkaline preparations.

(B) RESTRICTIONS OF USE

- (1) Before using any cleaning preparation, food products and packaging materials must be removed from the room or carefully protected. After using such preparations, all surfaces must be thoroughly rinsed with potable water.
- (2) Preparations having a characteristic odor of fragrance as diluted for use may, in the opinion of the **USDA**, interfere with sanitary inspection of food contact surfaces may not be used on food contact surfaces. They may be authorized for limited use on floors and walls only.
- (3) Preparations containing abrasive materials such as silica, pumice, etc. may be used on food contact surfaces only if care is taken to remove all odors or residues resulting from their use by thorough rinsing with potable water.
- (4) Boric acid and salts thereof, may be used in such preparations only at concentrations up to 90 percent in association with strong acids, strong alkalis, soaps, or synthetic detergents.

Chapter 7: Maintenance continued:

7.4 General Maintenance Checklist

- Check regularly for loose screws.
- Check the oil level in the lubricator regularly
- Check the air filter on a regular basis
- Check the knife for signs of chipping
- Check the end of the punch for burrs
- Check guards for safe function

Check for and tighten all loose connections and screws before returning machine to operation. Check for and remove any burrs around die pocket on the clipper.

While cleaning, inspect for worn or damaged components needing replacement. For replacement parts refer to the list or recommended spare parts and assembly drawings.

7.5 Trouble shooting Guide

Symptoms

Solution

No power

- Air connection may be loose. Check all air connections.
- or Regulator may be turned off. Check the regulator unit.
- or Water may be in the system. Drain and change the filter.

Check motor starter and Electrical supply

- Not turned on.
- or Starter not tripping. Check for curcuit failure,
- or bad connections.

Clipper is slow

- Water may be in the system. Drain the water and change the filter.
- or Muffler may be clogged. Replace the muffler.
- or Pressure to the clipper is low. Check the pressure setting and increase if necessary.
- or Air lines are pinched. Replace the air lines.
- or Cylinder is stuck. First check for pinched air line and check the air pressure. If cylinder is still stuck, disconnect air line and check for broken or worn parts. Replace bad parts or air cylinder.

Punch does not retract

Knife blade housing may be jammed with product residue. Disassemble and clean.

Knife does not cut

Check knife for nicks and sharpen as needed.

Malformed clips

- Punch or die may be damaged. Replace as necessary.
- or Air pressure may be too low or too high. Check air pressure and adjust if necessary.

Clips are loose and seal poorly

- Check crimp control and adjust if needed.
- or Air pressure is to low. Check air pressure and adjust if necessary.
- or Punch and die may be worn down. Check for wear on punch and die, and replace if needed.

No vacuum/ poor vacuum/ does not shut off

- Vacuum pump turned off, (turn ON)
- or Vacuum pump low on lubricating oil
- or vacuum lines disconnected or loose.
- or Check Ball valve, nozzle assembly.

Chapter 8: Spare parts List

When ordering replacement or spare parts, always include the following:

Machine model number and date of purchase:

Identifying part numbers stamped on part:

**Part number or numbers on spare parts list,
or identifying item numbers on assembly drawings:**

8.1 Recommended Spare parts

Item	Part No.	Description	Qty.
1	21-0043	Valve	1
2	21-0259	Gate Valve	1
3	24-0045	Filter element	1

8.2 Loose Parts List

Item	Part No.	Description	Qty.
1	24-9930	White oil (ISO VG32 Equivalent)	1
2	80-1409	Model Operators Manual	1

Chapter 9: Assembly Drawings

CVW	Assembly
	CVW Vacuum Schematic
00-0590	Vacuum pipe
00-1512	Waste tank
00-1514	3/4 HP Vacuum pump
00-4153	Waste tank sub assembly
00-4512	Product table
00-4526	ON-OFF switch assembly
63-0071	Pneumatic schematic

Modular Type F.R.L. Combination

Filter • Regulator • Lubricator • Filter/Regulator
Mist Separator • Micro Mist Separator

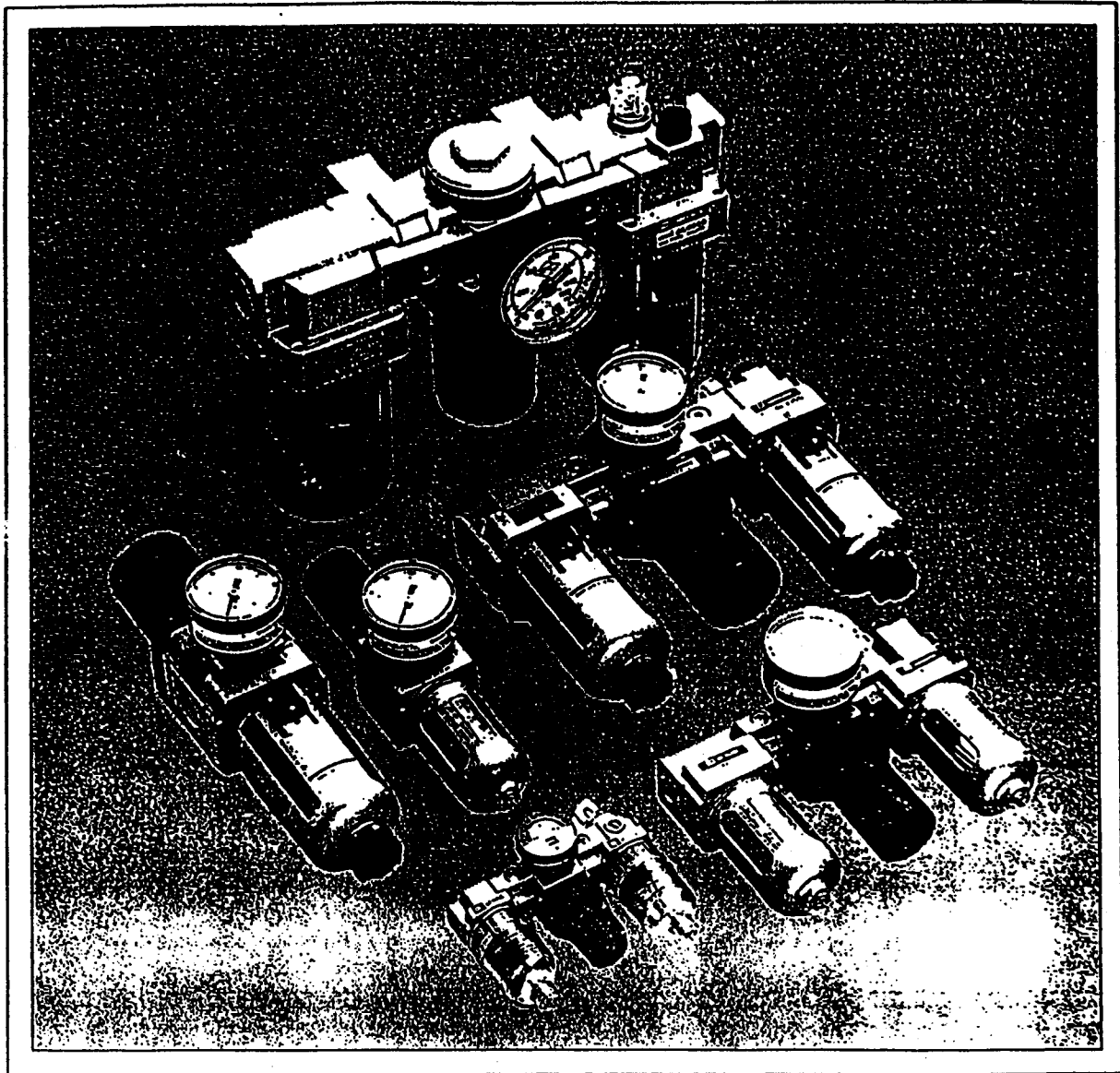

 **SMC**
SMC Pneumatics, Inc.

Modular Type F.R.L. Combination

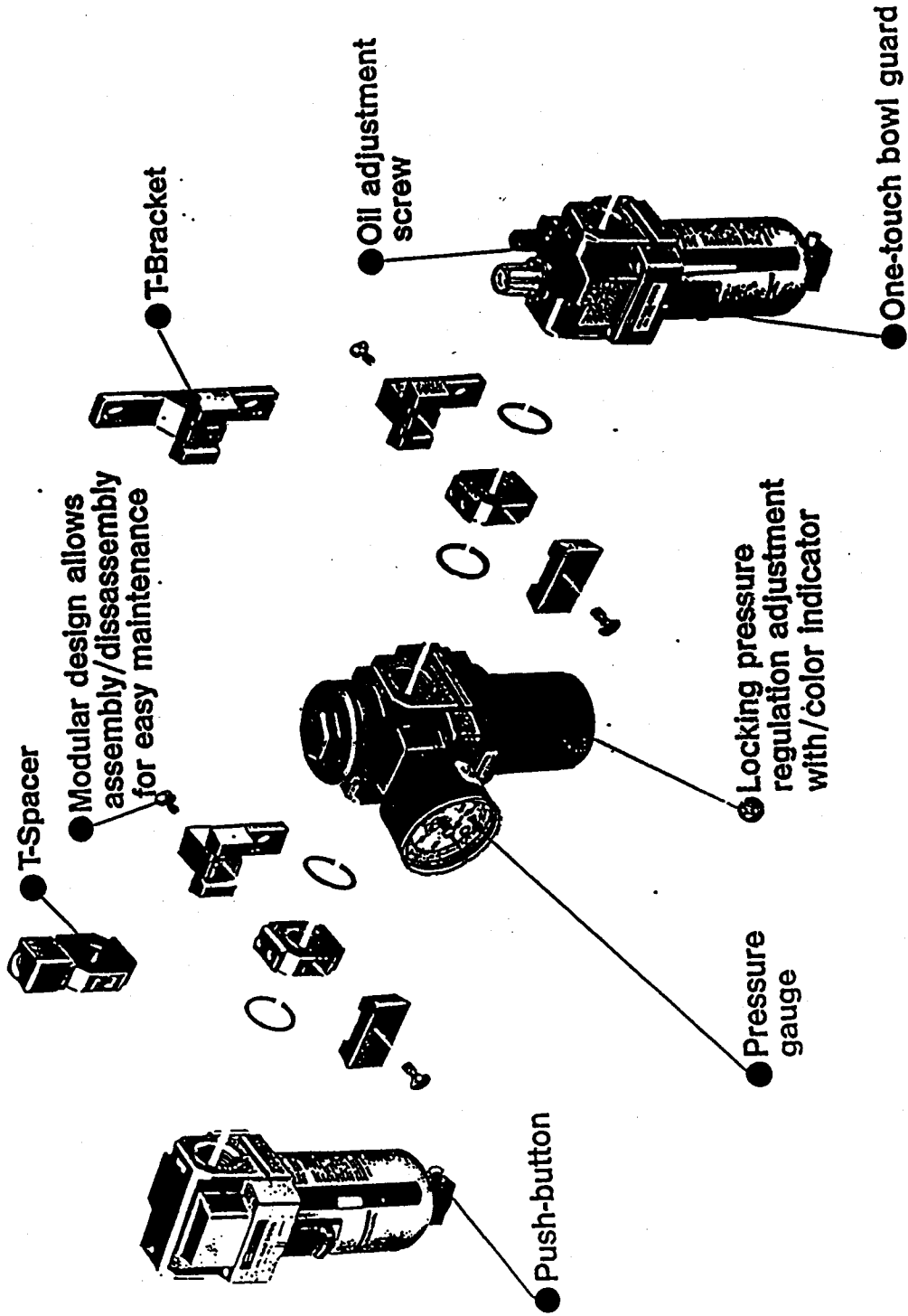

Flow Characteristics

Operating Pressure: 100 PSI

NAL1000

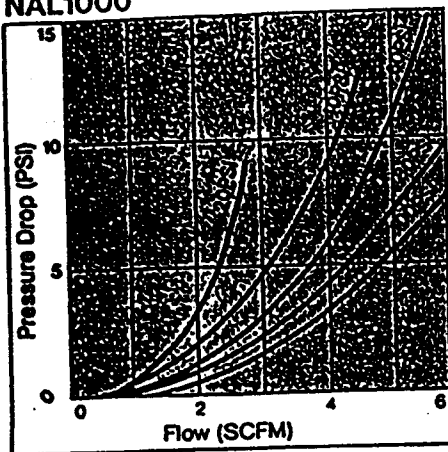

NAL2000

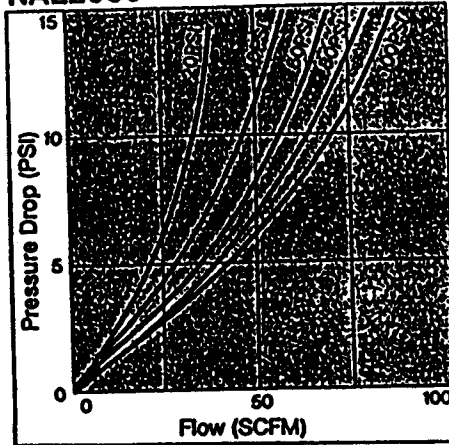

NAL3000

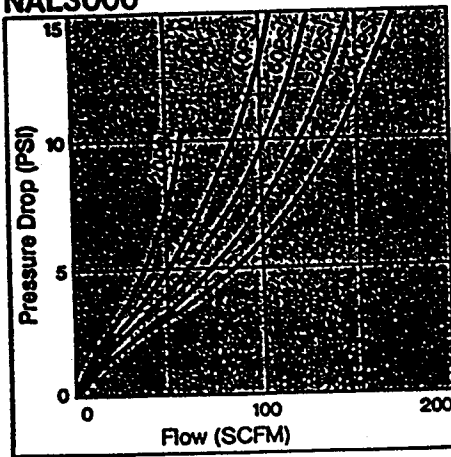

NAL4000

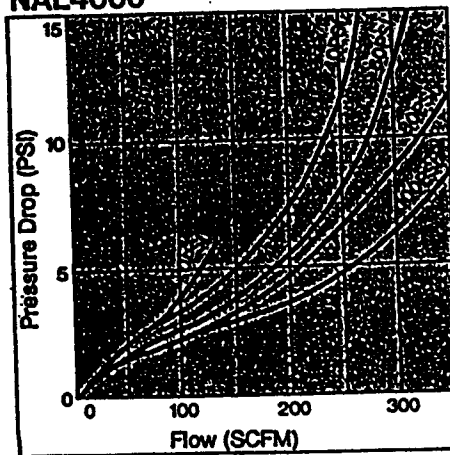

NAL1000

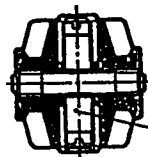

2 Needle

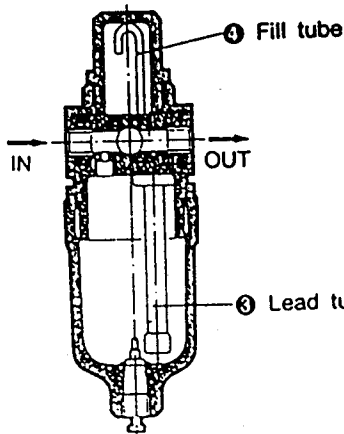

3 Lead tube

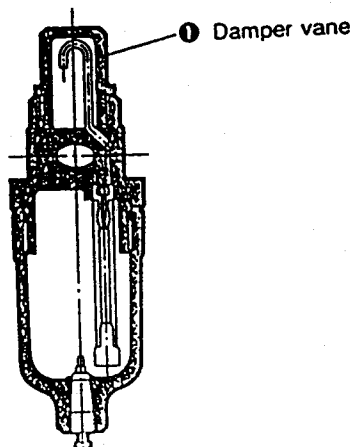

1 Damper vane

Precautions

Installation

- ① Recommended oil is ISO VG32.
- ② Flush piping before installation.
- ③ If intended for use with power presser, please consult SMC factory

Atmosphere

- ① Polycarbonate bowls may be damaged and possibly fail if exposed to synthetic oils, thinner solvents, trichlorethylene, kerosene and other aromatic hydrocarbons. If used above atmosphere a metal bowl is recommended.

Refill

- ① A minimum air flow is required for proper operation. (see specifications). Please sure the minimum requirements are met.
- ② NAL1000, 2000 type lubricators cannot be refilled under pressure. Shut off air pressure before refilling.

NAL4000-N06

3/4

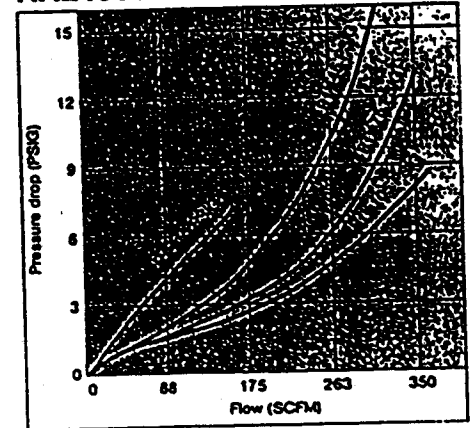

Air entering from the inlet port pressurizes the surface of the oil then flows through the needle valve to the outlet port. As a result of the differential pressure between the pressure in the bowl and the pressure in the damper vane, oil is passed through the lead tube and dropped out of the fill tube into the flow path of the air. Oil flow is adjusted by turning the front needle. Clockwise turns will increase oil drop rate and counter-clockwise will decrease oil drop rate. Leave the backside needle fully open.

Flow Characteristics

* Operating pressure: 100PSI (7kgf/cm²)

NAW1000

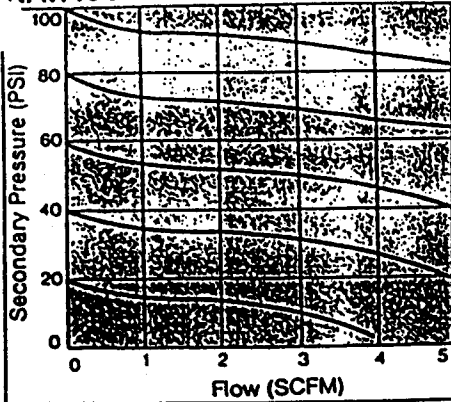

NAW2000

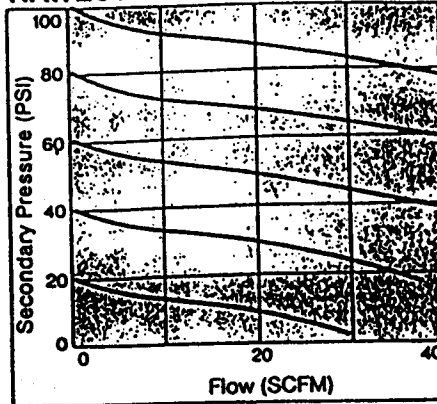

NAW3000

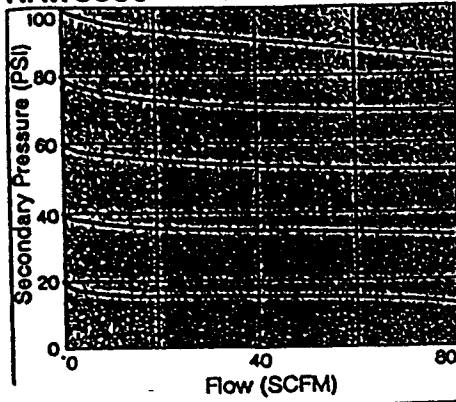

NAW4000

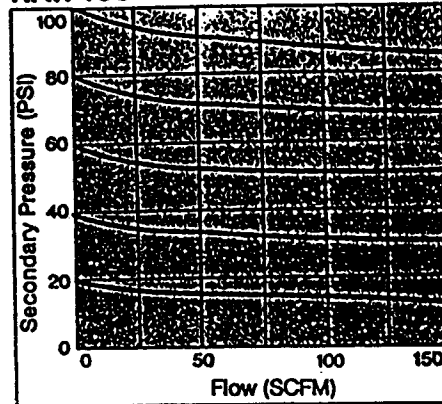

* Operating pressure: 100PSI (7kgf/cm²)
 Secondary Pressure: 30PSI (2kgf/cm²)
 Flow rate: 0.7SCFM (20Nl/min)

Pressure Characteristics

NAW1000

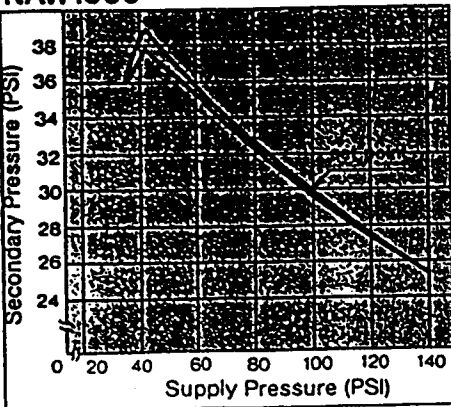

NAW2000

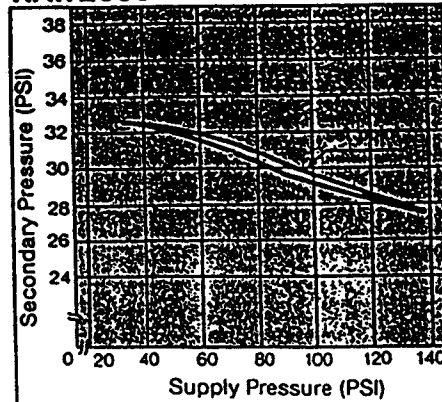

NAW3000

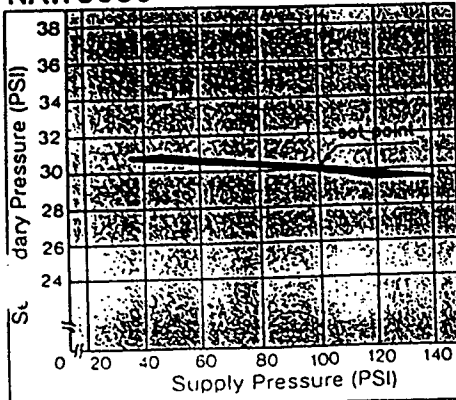

NAW4000

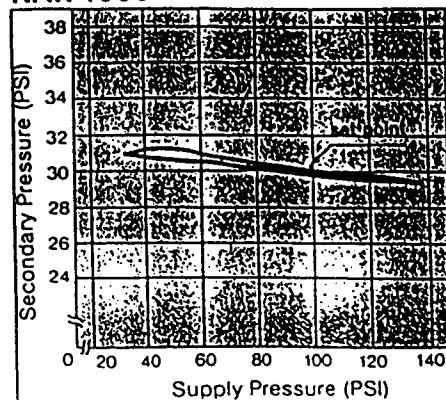

Setting

- ⊙ The adjustment knob is a locking type. Pull the knob away from the body until the orange band is visible. Adjust as necessary and push the knob back into its locked position to prevent accidental setting change.

Orange band



- ⊙ Turning the adjustment knob clockwise increases the pressure and turning the knob counterclockwise reduces the pressure.

Precautions

Installation

- ⊙ Flush piping before installation.
- ⊙ The use of piping adapters will make installation easier.
- ⊙ Must be installed with the knob up because the filter must be facing down.

Maintenance

- ⊙ Filter element should be changed after 1 year or when a pressure drop of 15 PSI (1 kgf/cm²) is reached.

Also Do

- ⊙ Drain line should be 1/8 inch (8mm) O.D. or more and should be less than 16.5 ft. (5m) long. Be sure not to have any upward turns in the drain line which could prevent drainage.
- ⊙ Unsuitable for flow below 3.5 SCFM (100Nl/min).
- ⊙ Operating pressure is more than 15 PSI (1kgf/cm²).
- ⊙ Soft nylon tube of more than 1/8 inch (φ2.5) O.D. is recommended for drain pipe. The length should be less than 16.5 ft. (5m) long.
- ⊙ Should be installed vertically.

NAW4000-06

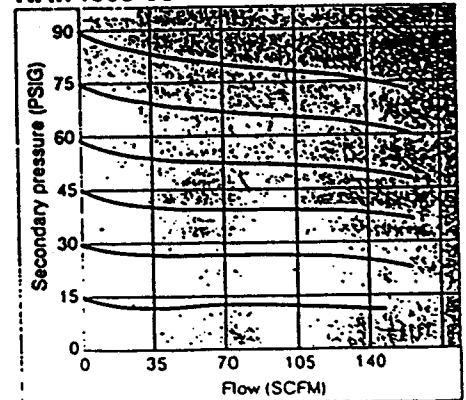

NAW4000-06

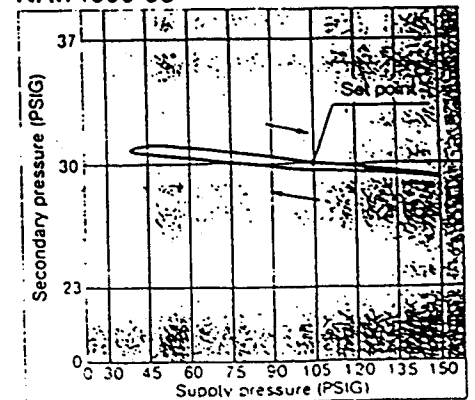

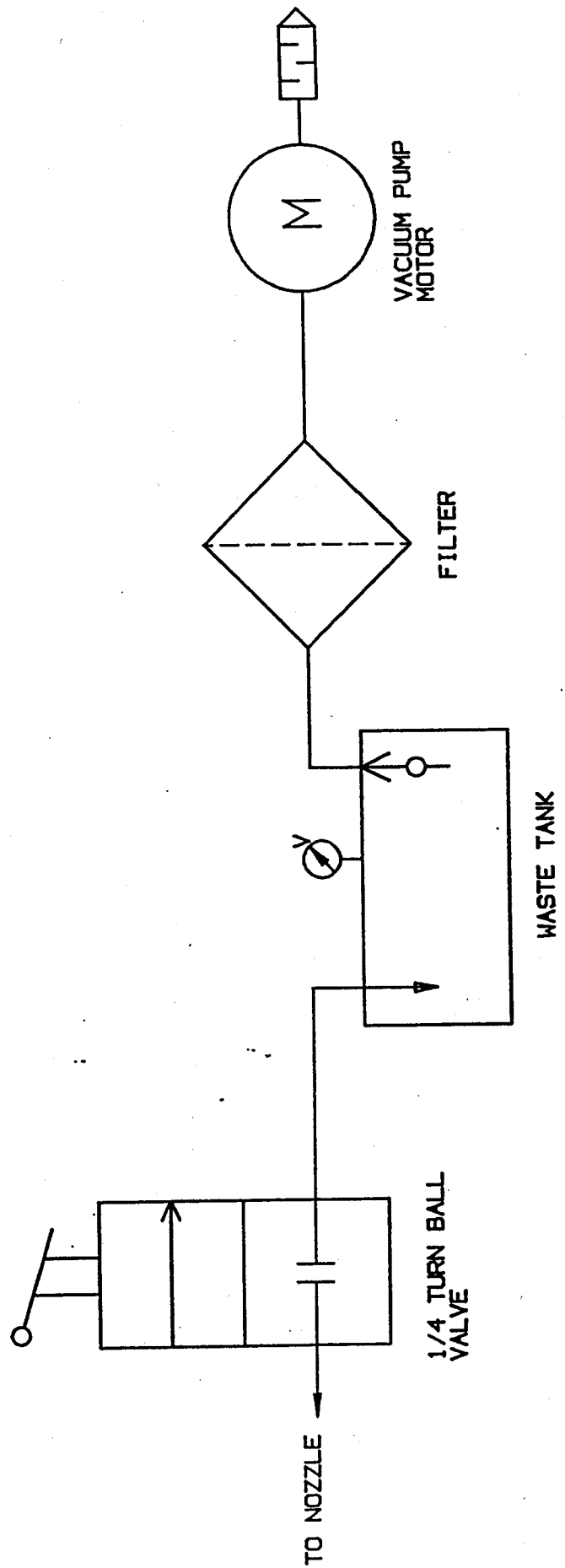

CVW VACUUM SCHEMATIC

CV-CL

CV-CR

CV-HL

CV-HR

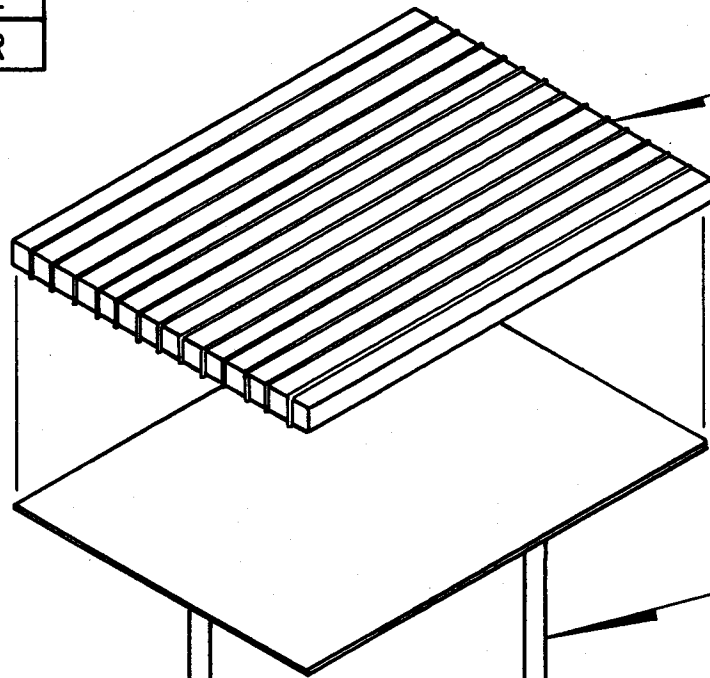

01-0159 1 REQ'D.
PRODUCT TABLE

01-0157 1 REQ'D.
SUB-PRODUCT TABLE

17-0151 2 REQ'D.
SPRING

00-0148 1 REQ'D.
LOCK BAR ASSEMBLY

28-4521 REF.
GREASE FITTING

20-0154 1 REQ'D.
KNOB

PRODUCT TABLE ASSEMBLY
00-4512 4-24-75

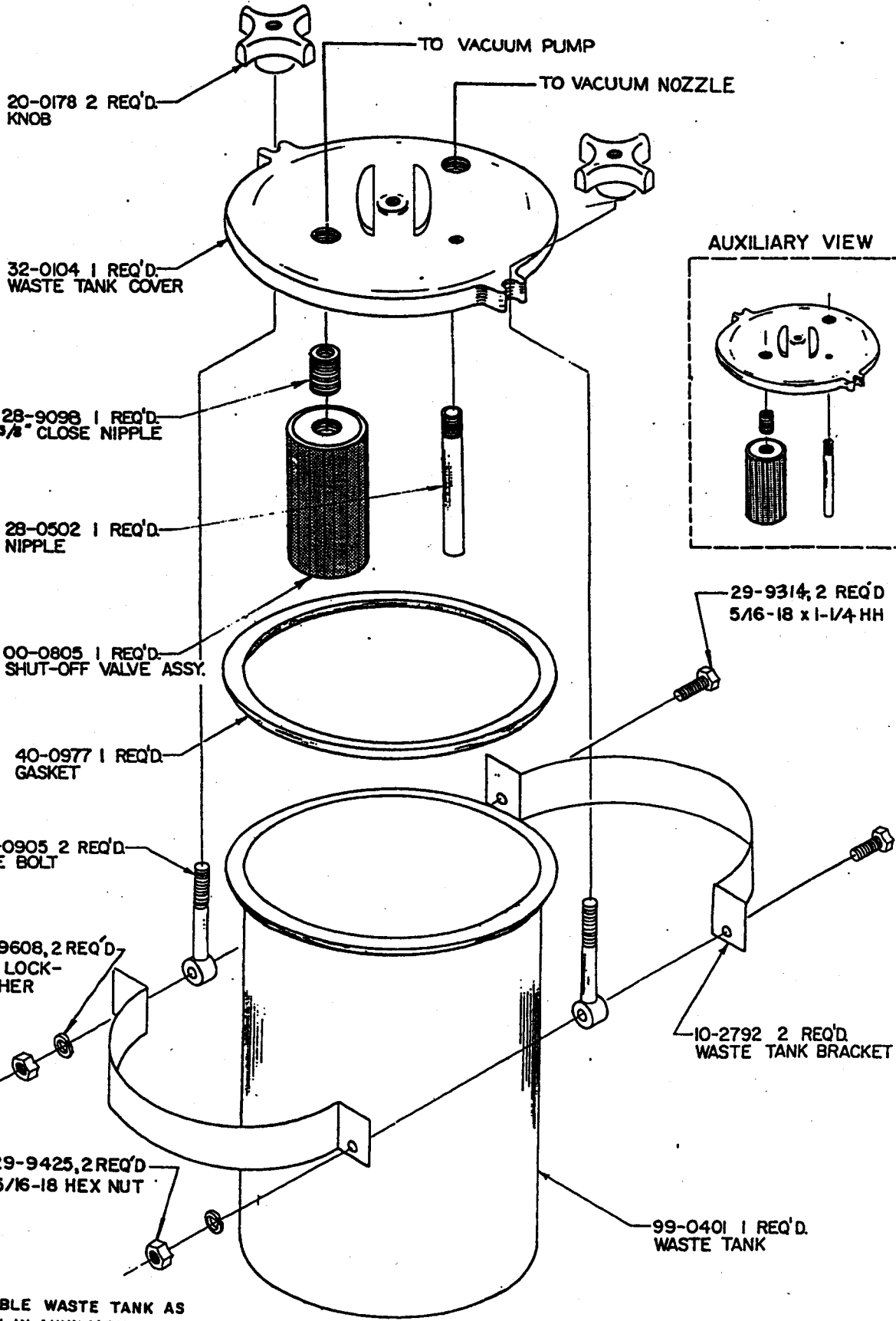

NOTE:

ASSEMBLE WASTE TANK AS SHOWN IN AUXILIARY VIEW FOR USE ON RIGHT HAND CLIPPER VAC CABINETS.

WASTE TANK ASSEMBLY

REV 4

00-4153

3-6-87

REVISIONS

NO.	DESCRIPTION	DATE	APPROVED	NO.	DESCRIPTION	DATE	APPROVED

1. INTERPRET DRAWING PER LATEST ANSI STANDARDS.
2. UNLESS OTHERWISE NOTED, REMOVE ALL BURRS AND BREAK ALL EDGES.
3. MATERIAL:

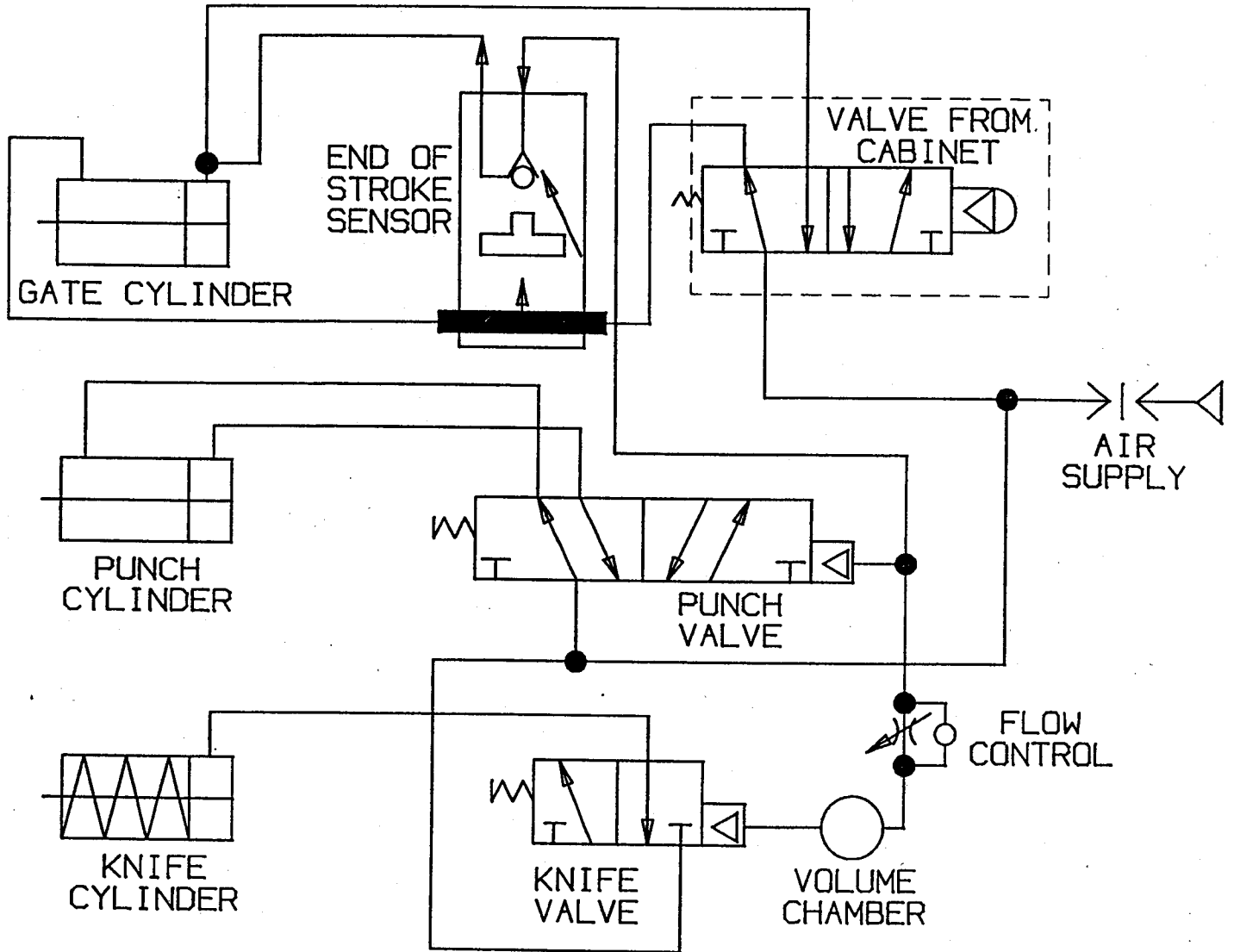

 TIPPER TIE [®] <small>ADDER INDUSTRIES COMPANY</small>	CHECKED BY _____ DATE _____	PNEUMATIC SCHEMATIC	
	APPROVED BY _____ DATE _____	SIZE A	PART NO. 63-0071-00
DRAWN BY B.DIGESO DATE 11/11/93	RELEASED BY _____ DATE _____	SCALE NTS	DO NOT SCALE DRAWING SHEET 1 of 1

USED ON
00-4520
00-0998
00-1424
00-5952

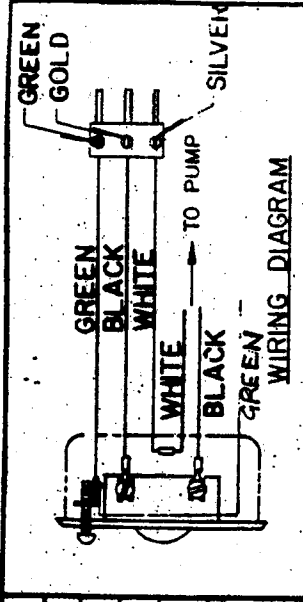

30-9954, 1 REQ'D.
17CM50 COVER

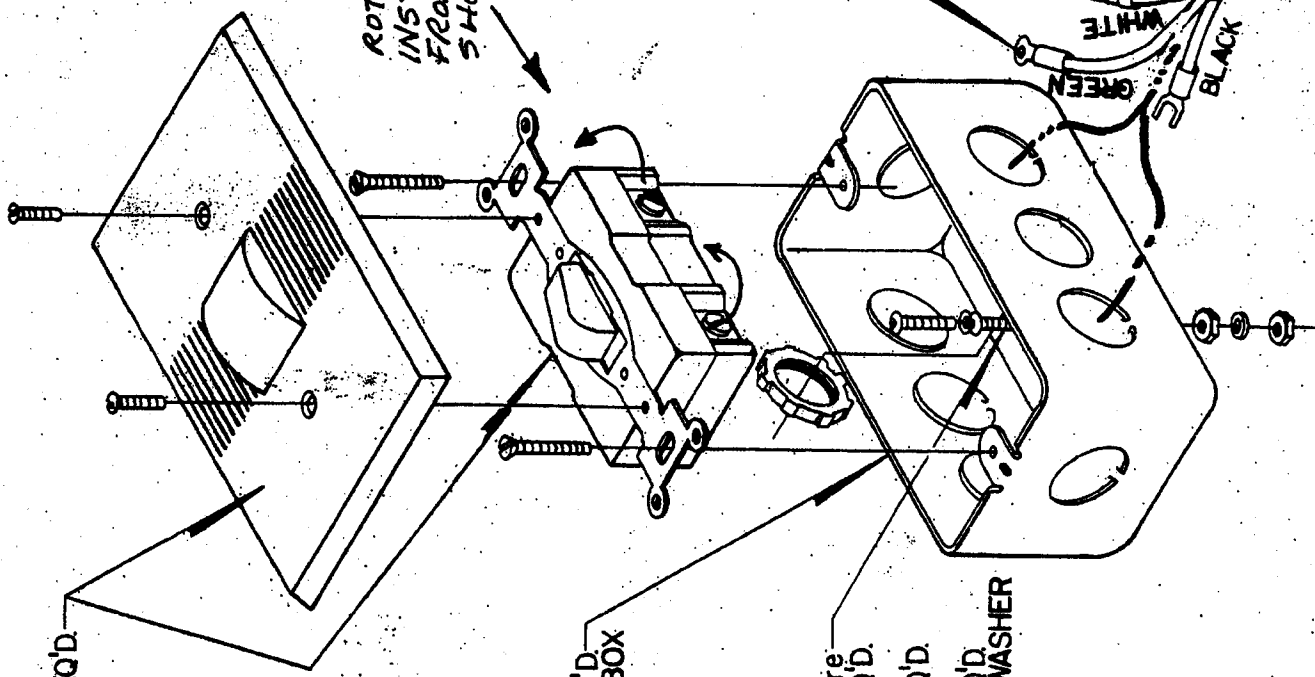

30-9955, 1 REQ'D.
HANDY SWITCH BOX

- Mounting Hardware
- 29-9182 2 REQ'D.
 - 10-32 x 5/8 BH
 - 29-9421 4 REQ'D.
 - 10-32 HEX NUT
 - 99-9603 4 REQ'D.
 - #10 INT/T LOCKWASHER

- 30-9952 2 REQ'D.
- 4X308 RING CONNECTOR
- 30-9953 1 REQ'D.
- 4X313 BUTT CONNECTOR
- 30-9958 2 REQ'D.
- 4X299 SPADE CONNECTOR
- 30-9956 2 REQ'D.
- T & B CORD GRIP

30-9944 2 REQ'D.
1/4 FEMALE QUICK DISC

30-9951 28 IN. REQ'D.
16/3 ELECTRIC CORD

30-3842
GND. FAULT CIRCUIT INT

30-9951 9 FT.
16/3 ELECTRIC CORD

ON-OFF SWITCH ASSEMBLY
00-4526-07 3.5.87.

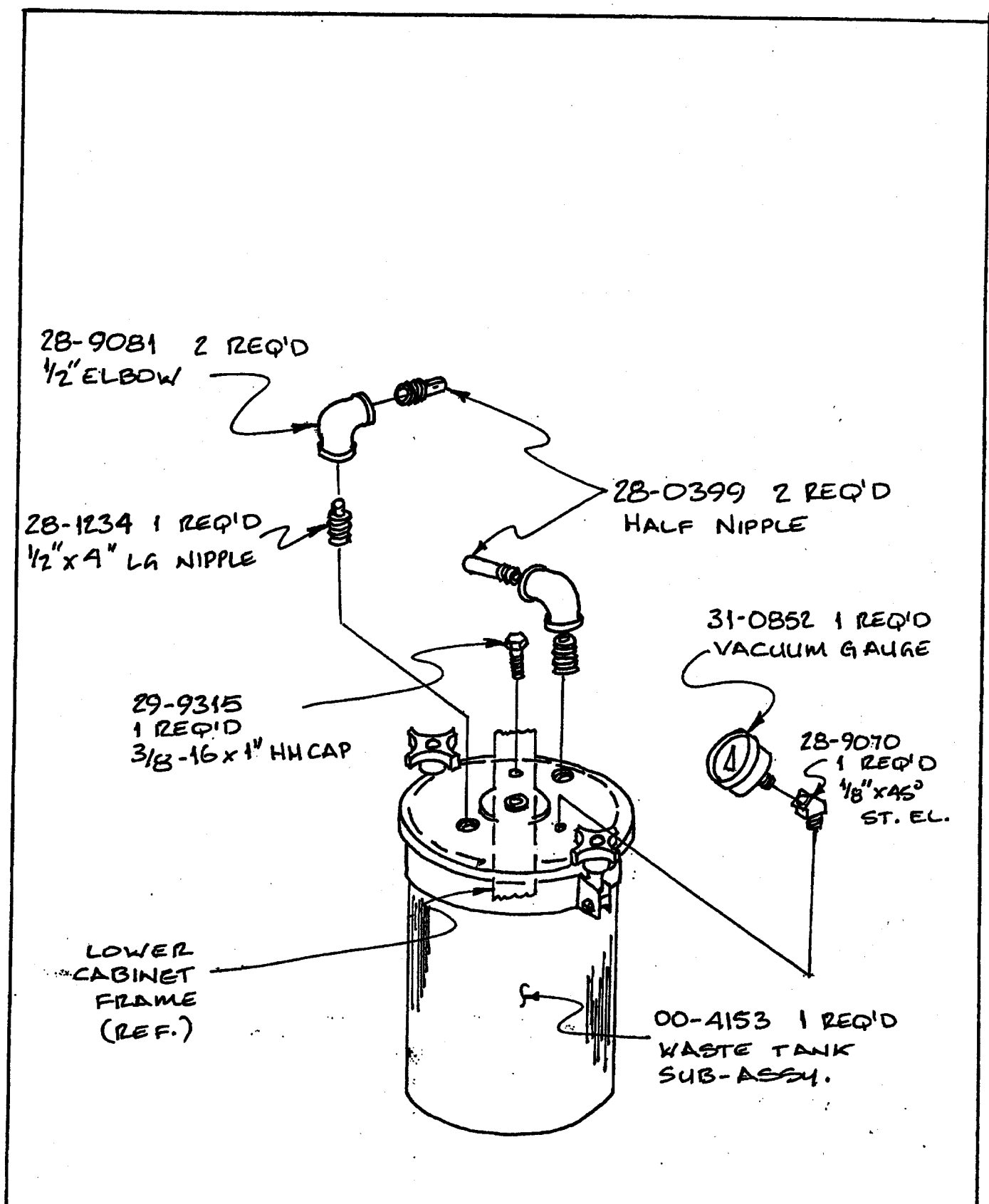

Rev 03		WASTE TANK ASSY CYW
		00-1512 12/21/00

DETAIL "A"
 SCALE 2:1

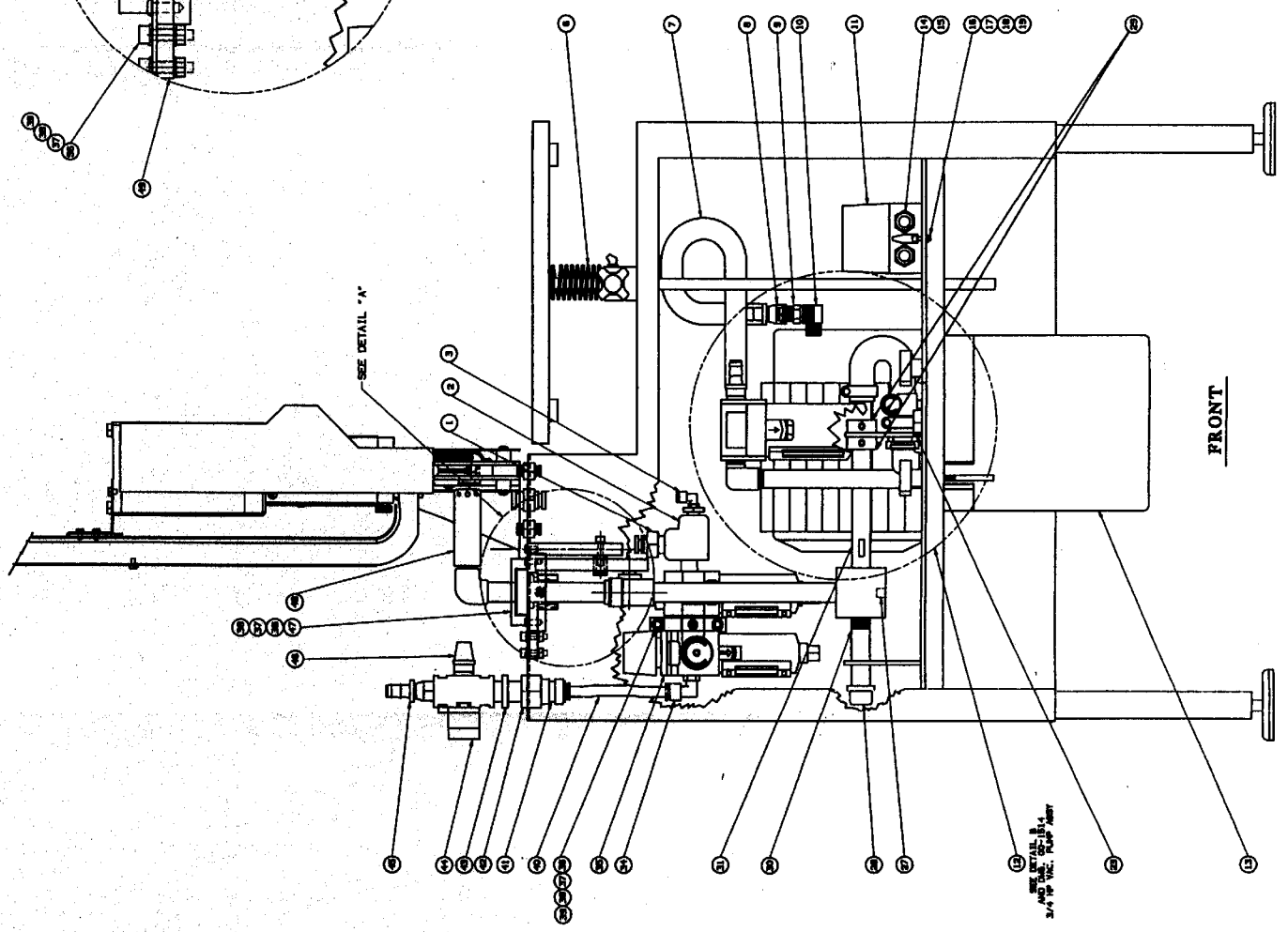
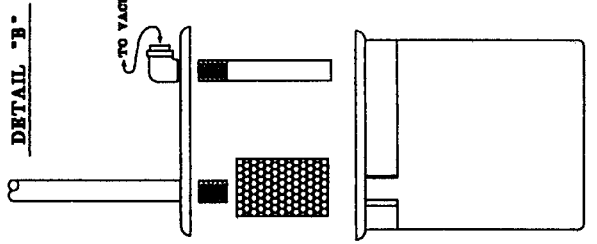
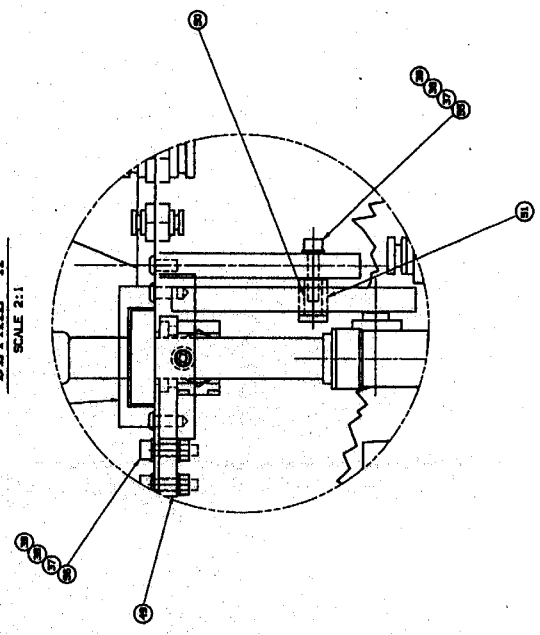

FRONT

SEE DETAIL B
 AND TABLE FOR
 3/4" DIA. PUMP ARM

NO.	DESCRIPTION	QTY.	UNIT	REMARKS
1	1/2" DIA. PUMP ARM	1	PC	
2	1/2" DIA. PUMP ARM	1	PC	
3	1/2" DIA. PUMP ARM	1	PC	
4	1/2" DIA. PUMP ARM	1	PC	
5	1/2" DIA. PUMP ARM	1	PC	
6	1/2" DIA. PUMP ARM	1	PC	
7	1/2" DIA. PUMP ARM	1	PC	
8	1/2" DIA. PUMP ARM	1	PC	
9	1/2" DIA. PUMP ARM	1	PC	
10	1/2" DIA. PUMP ARM	1	PC	
11	1/2" DIA. PUMP ARM	1	PC	
12	1/2" DIA. PUMP ARM	1	PC	
13	1/2" DIA. PUMP ARM	1	PC	
14	1/2" DIA. PUMP ARM	1	PC	
15	1/2" DIA. PUMP ARM	1	PC	
16	1/2" DIA. PUMP ARM	1	PC	
17	1/2" DIA. PUMP ARM	1	PC	
18	1/2" DIA. PUMP ARM	1	PC	
19	1/2" DIA. PUMP ARM	1	PC	
20	1/2" DIA. PUMP ARM	1	PC	
21	1/2" DIA. PUMP ARM	1	PC	
22	1/2" DIA. PUMP ARM	1	PC	
23	1/2" DIA. PUMP ARM	1	PC	
24	1/2" DIA. PUMP ARM	1	PC	
25	1/2" DIA. PUMP ARM	1	PC	
26	1/2" DIA. PUMP ARM	1	PC	
27	1/2" DIA. PUMP ARM	1	PC	
28	1/2" DIA. PUMP ARM	1	PC	
29	1/2" DIA. PUMP ARM	1	PC	
30	1/2" DIA. PUMP ARM	1	PC	
31	1/2" DIA. PUMP ARM	1	PC	
32	1/2" DIA. PUMP ARM	1	PC	
33	1/2" DIA. PUMP ARM	1	PC	
34	1/2" DIA. PUMP ARM	1	PC	
35	1/2" DIA. PUMP ARM	1	PC	
36	1/2" DIA. PUMP ARM	1	PC	
37	1/2" DIA. PUMP ARM	1	PC	
38	1/2" DIA. PUMP ARM	1	PC	
39	1/2" DIA. PUMP ARM	1	PC	
40	1/2" DIA. PUMP ARM	1	PC	
41	1/2" DIA. PUMP ARM	1	PC	
42	1/2" DIA. PUMP ARM	1	PC	
43	1/2" DIA. PUMP ARM	1	PC	
44	1/2" DIA. PUMP ARM	1	PC	
45	1/2" DIA. PUMP ARM	1	PC	
46	1/2" DIA. PUMP ARM	1	PC	
47	1/2" DIA. PUMP ARM	1	PC	
48	1/2" DIA. PUMP ARM	1	PC	
49	1/2" DIA. PUMP ARM	1	PC	
50	1/2" DIA. PUMP ARM	1	PC	

REVISIONS		DATE		BY		CHECKED BY		APPROVED BY	
1	INITIALS	DATE	DATE	INITIALS	INITIALS	INITIALS	INITIALS	INITIALS	INITIALS

SEE FIG. CVW-04
 REF. ECH.
 FOR BY 0210
 FOR BY 0210
 FOR BY 0210

CVW ASSEMBLY
 CVW-04

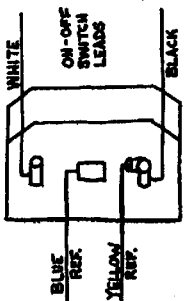

WIRING SCHEMATIC

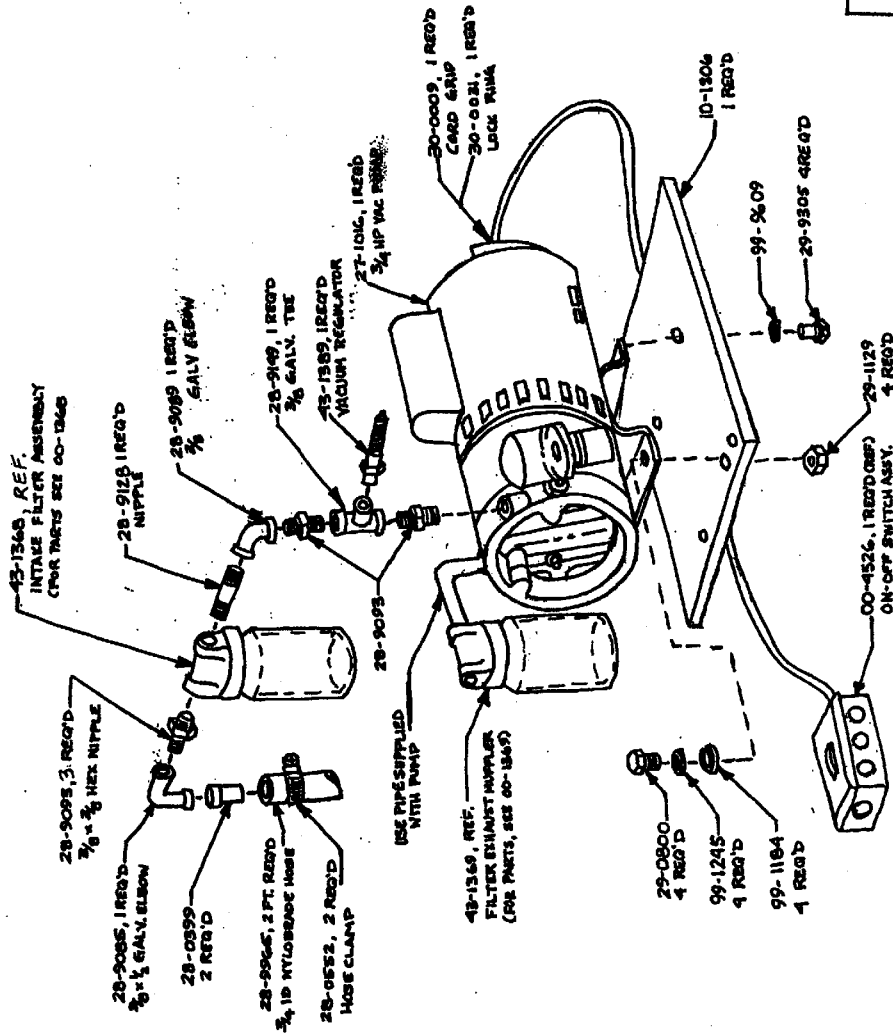

3/4 HP VAC. PUMP ASSEMBLY

01-18-01 00-1514-02