



## AIR POWERED VACUUM CLIPPER

ITEM NUMBER \_\_\_\_\_

JOB NAME / NUMBER \_\_\_\_\_



### Cleveland Standard Features

- Single Station, automatic, hand activated System
- Able to handle random sizes and weights
- Vertical mounted Clipper with automatic Clip feeding mechanism, Safety shut-off Valve and Air Pressure Gauge
- Vacuum Pump and Controls Mounted in Stainless Steel Cabinet
- System complete with: Air Filter, Regulator and Pneumatic Lubricator
- Easy removable Waste Container
- Adjustable Clip crimping Control and Clipping Cycle
- One continuous Operation: draws Vacuum, gathers Casing Neck, clips and cuts Tailing
- Cabinet with adjustable Table Top, hinged Front and Side Doors

### Options & Accessories

- Casters
- Clips
- Labels

### Cleveland Standard Features

- Single station, hand activated vacuum packaging system
- Able to handle random sizes and weights
- Open base stainless steel cabinet
- Horizontal mounted Clipper
- Vacuum pump assembly complete with air filter, regulator and pneumatic lubricator
- Easily removable waste container
- Tabletop mounted Goose-neck pipe with vacuum nozzle and gauge

### Options & Accessories

- Casters
- Clips
- Labels

MODEL:  CVW



### Short Form Specifications

Shall be Cleveland Model CVW, Vacuum packaging system, Stainless Steel Cabinet, housing pneumatic Controls and On/Off Switch, vertical mounted Clipper with automatic Clip feeding, safety shut-off and Air pressure Gauge. Air Filter, Air regulator and pneumatic Lubricators. Cabinet with adjustable Table Top, and hinged front and side Doors.

MODEL:  CV-E-8065



### Short Form Specifications

Shall be Cleveland Model CV-E-8065, Vacuum packaging system, Stainless steel open stand with vacuum pump, horizontal mounted clipper, goose-neck assembly with vacuum gauge and hand activated nozzle.

MINIMUM CLEARANCE	
FRONT	36"
SIDE	12"
REAR	12"

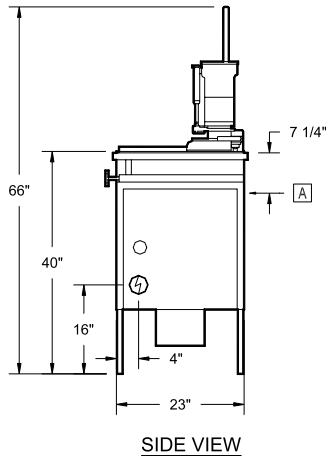
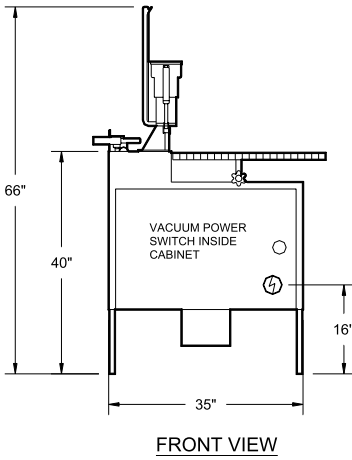
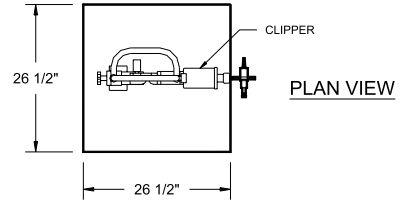
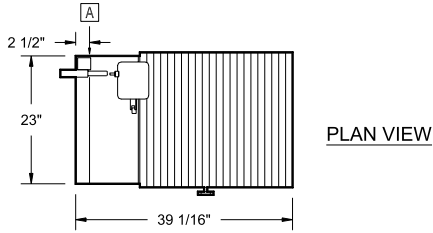

CVW

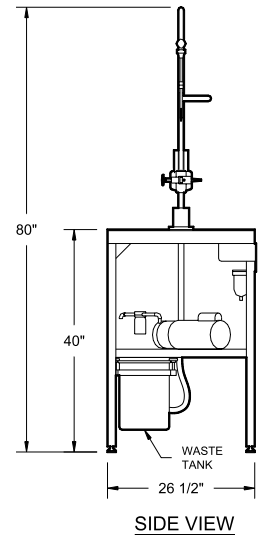
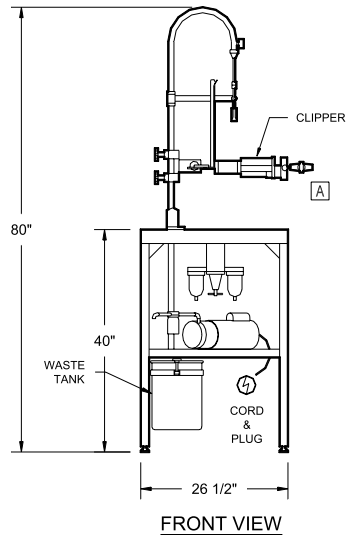

CV-E-8065

**UTILITIES**

MODEL	AIR	ELECTRICAL
	A	⚡
CVW	25 CFM, 90 to 110 PSI	120V/1PH – 10 amps cord and plug

MODEL	AIR	ELECTRICAL
	A	⚡
CV-E-8065	25 CFM, 90 to 110 PSI	120V/1PH – 10 amps cord and plug



# TIPPER TIE®

A  DOVER INDUSTRIES COMPANY

P.O. BOX 866 LUFKIN ROAD  
APEX, N.C. USA 27502-0866  
(919) 362-8811 or 1-800-331-2905  
FAX: (919) 362-8667

## Machine Manual Model CVE

Manual No. 80-0005  
Revision No. 14  
07/242001

# Tipper Tie Model CVE

## Table of Contents

### Chapter 1: Machine Description and Specifications

1.1 Description .....	5
1.2 Applications .....	5
1.3 Machine specifications .....	5

### Chapter 2: Safety Instructions

2.1 International Safety signs .....	6-7
2.2 Safety Instructions .....	8-9
2.3 Danger Areas .....	10

### Chapter 3: Delivery and Inspection

3.1 Delivery and inspection .....	11
3.2 Unpacking equipment .....	11

### Chapter 4: Air Connections and Lubrication

4.1 Installation of Main Air Supply .....	12
4.2 Filter / Regulator / Lubricator .....	12
4.3 Air regulator Assembly .....	13
4.4 Lubricator Adjustment .....	14
4.5 Regulator Adjustment .....	15

### Chapter 5: Operation: Product packaging

5.1 Preparation .....	15
5.2 Vacuum Nozzle operation .....	15
5.3 Operating the Clipper .....	16
5.4 Cut-Off Knife operation .....	16
5.5 Operating features .....	17

### Chapter 6: Cleaning Procedure

6.1 U.S. Department of Agriculture Guidelines .....	18-19
6.2 Cleaning Procedure .....	20

### Chapter 7: Maintenance

7.1 General maintenance Checklist .....	21
7.2 Lubricator Maintenance .....	22
7.3 Filter / Regulator Maintenance .....	22
7.4 Vacuum Pump .....	23
7.4.1 Electrical requirements .....	23
7.4.2 Lubrication System (vacuum pump) .....	23
7.4.3 Oil type .....	24
7.4.4 Motor .....	24
7.4.5 Flushing .....	24
7.4.6 Disassembly .....	24

**Chapter 8 Trouble Shooting Guide** ..... 25

**Chapter 9: Replacement or Spare Parts**

9.1 Loose Parts List ..... 26

**Chapter 10: Assembly drawings** ..... 27

Tipper Tie Warranty:

- (a) Tipper Tie warrants to Purchaser that equipment manufactured by Tipper Tie and sold to Purchaser hereunder shall be free from defects in material and workmanship under normal use and service for the earlier of (i) a period of one year from the date of installation of the equipment, or (ii) the period ending when the equipment has run the number of Machine Cycles as specified on Addendum A attached hereto for the particular model of equipment purchased by Purchaser (the "Warranty Period"). Any claim made under this warranty must be presented, in writing, to Tipper Tie during the Warranty Period. Tipper Tie makes no warranties as to any equipment or accessories not manufactured by Tipper Tie, and Purchaser shall be limited only to the warranties, if any, provided by the manufacturer of such equipment or accessories.
- (b) Tipper Tie's sole responsibility for any breach of the warranty contained herein shall be to repair or replace at Tipper Tie's option and, at Tipper Tie's sole cost and within a commercially reasonable period following receipt of a claim from Purchaser within the Warranty Period, items, components and/or parts not conforming to such warranty, f.o.b. Apex, North Carolina. All parts replaced by Tipper Tie shall become the property of Tipper Tie.
- (c) The foregoing warranty shall not apply to, nor shall Tipper Tie be responsible for, damages resulting from normal or excessive wear and tear of the equipment or component parts thereof (such component parts to include, but not be limited to, punches, dies, knife blades, skin brakes, conveyor belts and other parts which by their nature and as a result of normal equipment operation wear out and must be replaced), improper operation, operating under improper conditions or defects resulting from faulty installation which has not been carried out by Tipper Tie. The warranty becomes immediately void in every case where repairs, modifications or alterations are carried out by the Purchaser or by third parties, without the prior written consent of Tipper Tie. The warranty also does not cover any damages caused by insufficient, incorrect or forceful operation of the equipment, failure to observe the operating instructions, overloading, the use of materials, consumables or accessories not manufactured by Tipper Tie or specifically approved in writing by Tipper Tie for use with the equipment, chemical or electrolytic action, the use of spare parts from an outside source, or any event of force majeure.
- (d) **THERE ARE NO WARRANTIES, EXPRESS OR IMPLIED, GIVEN BY TIPPER TIE EXCEPT AS SET FORTH IN THIS WARRANTY SECTION, AND TIPPER TIE EXPRESSLY DISCLAIMS ALL OTHER WARRANTIES, INCLUDING BUT NOT LIMITED TO ANY AND ALL IMPLIED WARRANTIES OF MERCHANTABILITY OR FITNESS FOR A PARTICULAR PURPOSE. UNDER NO CIRCUMSTANCES SHALL TIPPER TIE'S LIABILITY HEREUNDER EXTEND TO OR INCLUDE LIABILITY FOR ANY SPECIAL, CONSEQUENTIAL, INCIDENTAL, PUNITIVE OR OTHER DAMAGES OF ANY KIND OR CHARACTER. THE WARRANTIES PROVIDED HEREIN MAY NOT BE ALTERED, EXTENDED OR VARIED EXCEPT BY A WRITTEN INSTRUMENT SIGNED BY TIPPER TIE AND PURCHASER.**

## ADDENDUM A

<u>Model Number</u>	<u>Cycles/minute</u>	<u>Machine Cycles</u>
RS4202M	14	1,400,000
SAMIIIIE	25	2,500,000
TB-15	15	1,500,000
TCM 2250, pump	8	800,000
TCM 2250, breech	5	500,000
PTM	17	1,700,000
PTRFMx, normal	30	3,000,000
PTRFMx, high speed	45	4,500,000
TC4353	15	1,500,000
Alpina DKF 18/15	80	8,000,000
Alpina DKF 15/12	150	15,000,000
	<u>Hours/day</u>	<u>Hour/year</u>
Rota-Clip	8	2000

Tipper Tie Warranty:

- (a) Tipper Tie warrants to Purchaser that equipment manufactured by Tipper Tie and sold to Purchaser hereunder shall be free from defects in material and workmanship under normal use and service for the earlier of (i) a period of one year from the date of installation of the equipment, or (ii) the period ending when the equipment has run the number of Machine Cycles as specified on Addendum A attached hereto for the particular model of equipment purchased by Purchaser (the "Warranty Period"). Any claim made under this warranty must be presented, in writing, to Tipper Tie during the Warranty Period. Tipper Tie makes no warranties as to any equipment or accessories not manufactured by Tipper Tie, and Purchaser shall be limited only to the warranties, if any, provided by the manufacturer of such equipment or accessories.
- (b) Tipper Tie's sole responsibility for any breach of the warranty contained herein shall be to repair or replace at Tipper Tie's option and, at Tipper Tie's sole cost and within a commercially reasonable period following receipt of a claim from Purchaser within the Warranty Period, items, components and/or parts not conforming to such warranty, f.o.b. Apex, North Carolina. All parts replaced by Tipper Tie shall become the property of Tipper Tie.
- (c) The foregoing warranty shall not apply to, nor shall Tipper Tie be responsible for, damages resulting from normal or excessive wear and tear of the equipment or component parts thereof (such component parts to include, but not be limited to, punches, dies, knife blades, skin brakes, conveyor belts and other parts which by their nature and as a result of normal equipment operation wear out and must be replaced), improper operation, operating under improper conditions or defects resulting from faulty installation which has not been carried out by Tipper Tie. The warranty becomes immediately void in every case where repairs, modifications or alterations are carried out by the Purchaser or by third parties, without the prior written consent of Tipper Tie. The warranty also does not cover any damages caused by insufficient, incorrect or forceful operation of the equipment, failure to observe the operating instructions, overloading, the use of materials, consumables or accessories not manufactured by Tipper Tie or specifically approved in writing by Tipper Tie for use with the equipment, chemical or electrolytic action, the use of spare parts from an outside source, or any event of force majeure.
- (d) **THERE ARE NO WARRANTIES, EXPRESS OR IMPLIED, GIVEN BY TIPPER TIE EXCEPT AS SET FORTH IN THIS WARRANTY SECTION, AND TIPPER TIE EXPRESSLY DISCLAIMS ALL OTHER WARRANTIES, INCLUDING BUT NOT LIMITED TO ANY AND ALL IMPLIED WARRANTIES OF MERCHANTABILITY OR FITNESS FOR A PARTICULAR PURPOSE. UNDER NO CIRCUMSTANCES SHALL TIPPER TIE'S LIABILITY HEREUNDER EXTEND TO OR INCLUDE LIABILITY FOR ANY SPECIAL, CONSEQUENTIAL, INCIDENTAL, PUNITIVE OR OTHER DAMAGES OF ANY KIND OR CHARACTER. THE WARRANTIES PROVIDED HEREIN MAY NOT BE ALTERED, EXTENDED OR VARIED EXCEPT BY A WRITTEN INSTRUMENT SIGNED BY TIPPER TIE AND PURCHASER.**

## ADDENDUM A

<u>Model Number</u>	<u>Cycles/minute</u>	<u>Machine Cycles</u>
RS4202M	14	1,400,000
SAMIIIIE	25	2,500,000
TB-15	15	1,500,000
TCM 2250, pump	8	800,000
TCM 2250, breech	5	500,000
PTM	17	1,700,000
PTRFMx, normal	30	3,000,000
PTRFMx, high speed	45	4,500,000
TC4353	15	1,500,000
Alpina DKF 18/15	80	8,000,000
Alpina DKF 15/12	150	15,000,000
	<u>Hours/day</u>	<u>Hour/year</u>
Rota-Clip	8	2000

# Chapter 1: Machine Description and Specifications

## 1.1 Description

The CVE is user friendly, and is specifically designed for processors who vacuum package a wide variety of products. The machine is easy to operate, and its simple design reduces downtime, for greater production. The machine's table is stainless steel, for ease of cleaning, in addition, all of the CVE's components are also readily accessible for easy cleaning and maintenance. The simple height adjustment of the vertical goose neck vacuum nozzle allows quick and easy changeover to accommodate differences in product size and shape. After drawing a vacuum on the package, the operator moves the package onto the clipper, where it is clipped and automatically trimmed.

Value added features such as an optional gas flush conversion kit, and various optional nozzle configurations are available to maximize the machine's versatility and cost effectiveness. Various clipper models are also available to optimize all sealing requirements. The clippers are designed to use either Z200 or Z400 series Tipper Tie clips.

## 1.2 Applications

The CVE is designed to handle a wide variety of products. The machine is ideal for packaging poultry parts, whole birds, turkey breasts, game birds, sausages, cheeses, and other products.

## 1.3 Machine Specifications

Vacuum pump: 26.5 HG. MAX.  
VAC., 8.0 CFM OPEN FLOW

Air Requirements:  
100 psi, (6,9 bars) MAXIMUM

Clip size:  
Z200 OR Z400 SERIES  
TIPPER TIE CLIPS

Machine weight: 200 LBS.  
Shipping weight: 250 LBS.

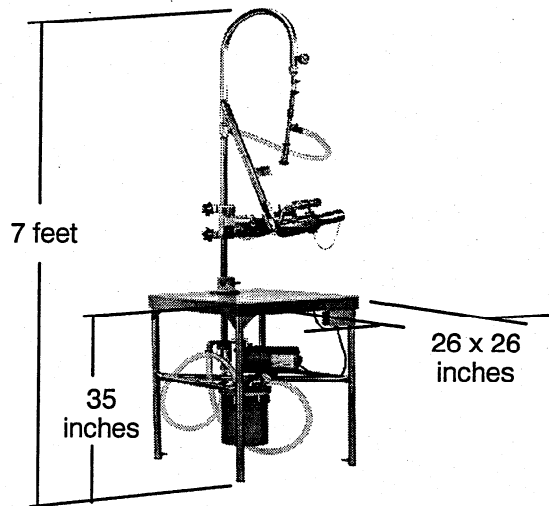

# Chapter 2: Safety Instructions

## 2.1 International Safety Signs

International safety signs are used to communicate hazard information used with appropriate machine functions.

- The yellow triangle signs warn of existing hazardous conditions.
- The blue circular signs define mandatory actions required.

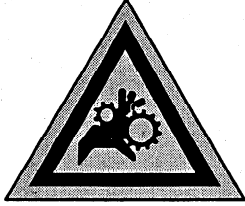

**WARNING: DANGER OF CRUSHING**

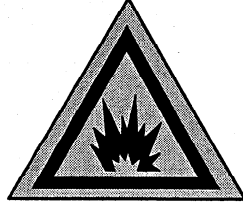

**WARNING: EXPLOSIVE ATMOSPHERE**

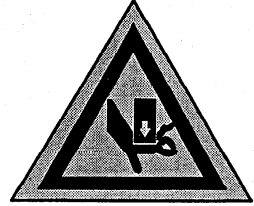

**WARNING: KEEP HANDS AWAY FROM PINCH AREA**

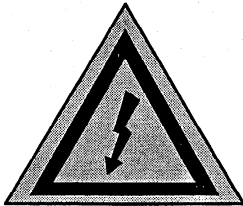

**WARNING: DANGEROUS ELECTRICAL CURRENT**

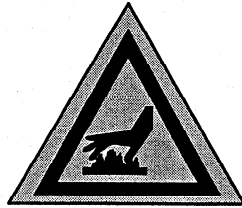

**WARNING: HOT SURFACE**

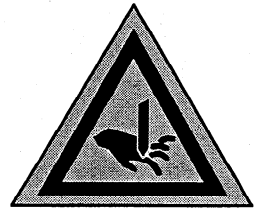

**WARNING: KEEP HANDS AWAY FROM KNIFE AREA**

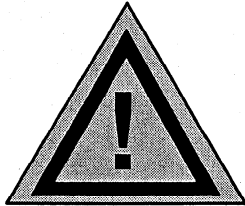

**WARNING:**



**READ MANUAL BEFORE SERVICING**

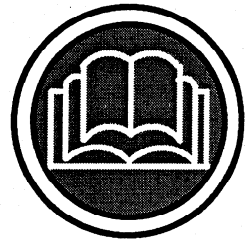

**READ MANUAL BEFORE OPERATING**



**ELECTRICAL LOCKOUT REQUIRED**

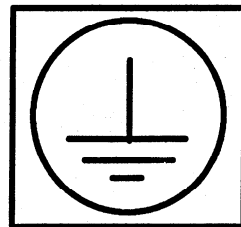

**PROTECTIVE EARTH GROUND**

## 2.1 International Safety Signs continued:

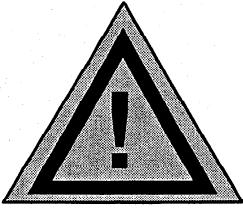

### **WARNING:**

When using this machine, all operating instructions, safety instructions and precautions must be followed and strictly adhered!

Do not attempt to install, setup or operate this machine before you have read and understood this manual and any accompanying supplier's manuals.

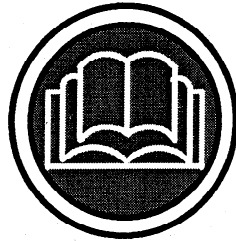

Follow all warnings and safety instructions in this manual. Failure to comply with safety instructions could result in serious injury.

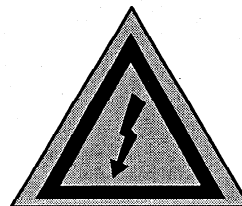
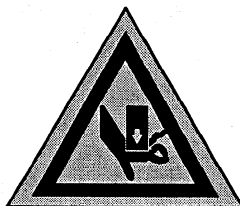

## 2.2 Safety Instructions

With the use of this machine, the following safety precautions must be obeyed:

- Before installing and first operating the machine, this manual must be read and understood. Follow all operating and safety instructions and exercise extreme care.
- **Warning:** This machine must be plugged in a ground fault circuit interruptor (GFCI) type receptacle. Failure to do so could cause injury or death.
- This machine must be installed securely, and permanently attached to a solid surface before starting and operating.
- This machine must be operated only by trained personnel. Training must be repeated at regular intervals.
- Safety devices must be checked each day to ensure proper operation. Safety features should be examined once each year by experts.
- All guards, protective covers and shields must be in place before operating the machine. Do not modify, remove, disable or bypass the guards. Operating this machine with guards, covers and shields removed could result in serious injury. **Never operate this machine without safety devices.**
- **The maximum working pressure for this machine is 100 psi, (6,9 bars)**  
Air pressure greater than this could cause an explosive rupture in any of the air lines or pneumatic components. Failure to adhere to this caution could result in personal injury or damage to the machine.
- Keep hands and fingers clear of the punch, die and knife areas at all times. Never touch these areas while the machine is in operation. Do not allow fingers, hands, jewelry or clothes around moving parts during operation of this machine.

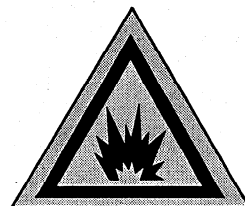
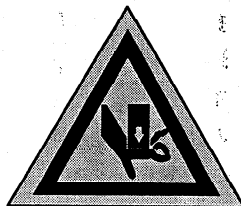

## 2.2 Safety Instructions continued:

- Immediately report any malfunction to the person in charge
- Stop machine to correct malfunctions.
- Disconnect air supply prior to servicing or moving the machine. The main air supply line must be disconnected from the machine before performing any service operation or maintenance.
- When this machine is not in operation, the air supply must be disconnected at the plant / regulator junction or at the quick disconnect on the machine. Failure to disconnect the air supply from this machine creates serious risk of injury. To prevent unauthorized personnel from operating this machine, rotate the red emergency stop valve 1/4 turn clockwise. Attach a padlock through the holes.
- When moving the machine, keep hands and fingers clear of punch, die and knife areas.
- Use only original spare parts and accessories.
- If the machine is sold, the manual must be supplied to the new owner.

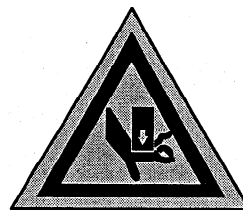
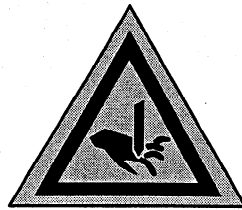

## 2.3 Danger areas

**Warning:**  
Keep hands and fingers clear  
of die, punch, and knife areas.

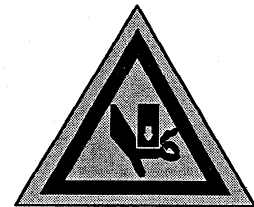
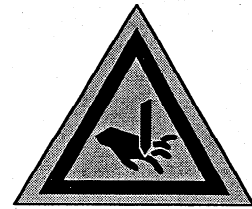
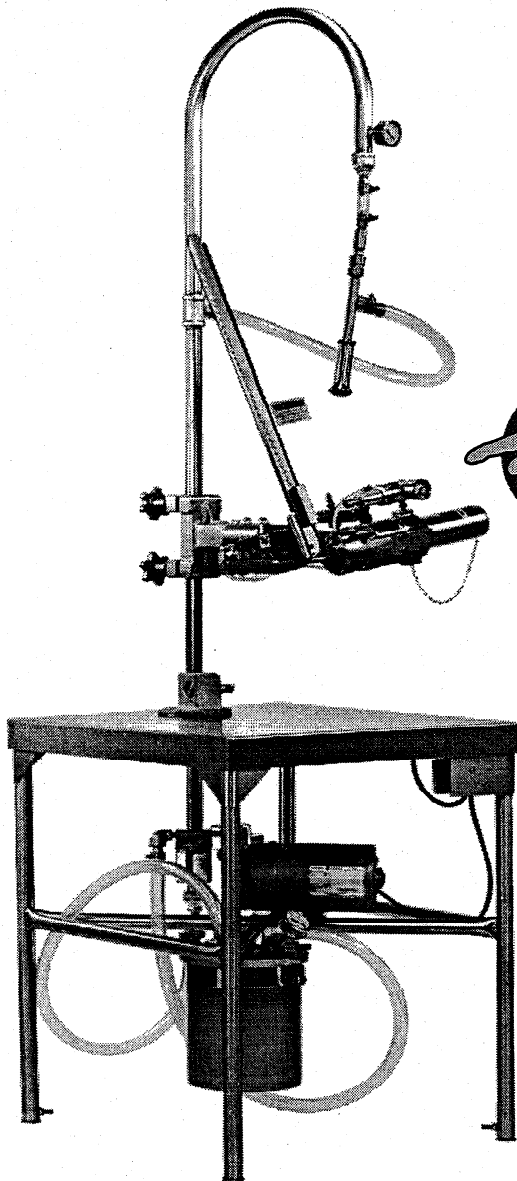

## **Chapter 3: Delivery and Inspection**

### **3.1 Delivery**

Upon delivery, inspect the shipping container and equipment for damages due to shipping and handling. If damage is found or suspected, contact the shipping agent immediately. In order that the carrier may have an opportunity to inspect goods and thereby properly verify claims, any loss or damage discovered after delivery should be reported to the agent of the delivering line immediately or within 15 days after receipt of goods.

In many instances, the original container is not opened and the contents not examined before reshipment to final destination. Therefore, under (SUBPART C: CLAIMS FOR LOSS OR DAMAGE: SECTION 1226.200 NATIONAL MOTOR FRIGHT CLASSIFICATION), 9 months are allowed for filing claims for loss or damages.

The shipping agent or carrier will help you in processing your claim. Remember to report all suspected damages immediately. If additional assistance is required, TIPPER TIE will gladly help in settling your claim. However, first contact the carrier or his agent involved.

WITH ALL CORRESPONDENCE, INCLUDE THE FOLLOWING:

- \* Original bill of lading or copy thereof. \*
- \* Vendor invoice, or certified copy, when claim is based on weight or valuation of shipment has been improperly described.
- \* Catalog pages or product information.
- \* Original packing slip or receiving reports.
  - \* or copy of electronic bill of lading manifest.

### **3.2 Unpacking Equipment**

For ease of shipping, partial disassembly of the machine sometimes is necessary. Check the shipping list and loose parts list to ensure that all items have been received. Do not discard packing materials until machine is assembled and operation. notify **Tipper Tie** immediately if any component is missing or if additional assistance is required.

Refer to the installation and operating instructions before starting to operate the equipment. Add all required oils and fluids, and make all machine adjustments as instructed before starting machine. Failure to do so may result in equipment damage or personal injury, and voids product warranty.

## **Chapter 4: Air Connections and Lubrication**

### **4.1 Installation of Main Air Supply**

Before operating, check all the air line connections as set at factory. If lines have become disconnected, reassemble. Air pressure can be regulated from the air regulator assembly. The air regulator assembly consists of filter, regulator, and oiler. Please note incoming air direction. (plant air flow) Assemble the factory air supply to the air regulator assembly by means of the quick-disconnect, connector. This quick-disconnect provides a means of removing the air supply for servicing and clean-up. The quick-disconnect must be attached with the check valve half (female), to the supply side of the air circuit.

The CVE is equipped with a filter, regulator, and lubricator unit. The air intake has ports tapped for 1/4" and 3/8" pipe thread. The filter is equipped with an automatic drain, and should be checked periodically to ensure it is draining off the moisture collected from the air lines. The lubricator must always have a supply of oil, otherwise the sealing rings within the air valves will wear out prematurely.

### **4.2 Filter / Regulator / Lubricator**

The filter must be kept clean to maintain maximum filtering efficiency. Open drain cock, under the filter periodically and drain off any bowl accumulation before it reaches level of lower baffle. A visible coating of dirt or condensate on the filter element surface or an excessive pressure drop is an indication that cleaning is necessary. To clean, turn-off air supply, and depressurize. Loosen locking collar and remove bowl. Clean all parts with denatured alcohol and blow-out the inside with compressed air.

### 4.3 Air Regulator Assembly

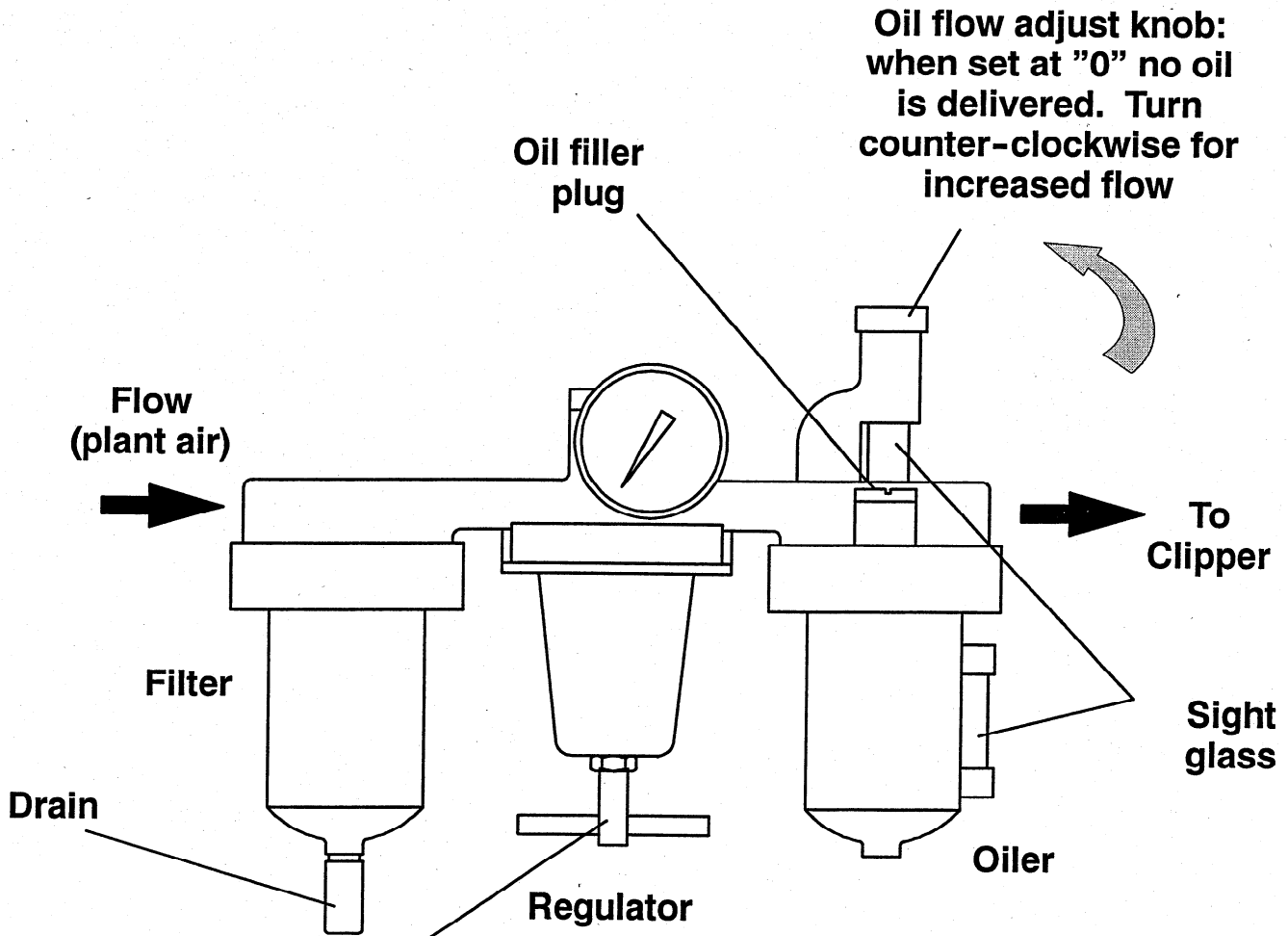

Oil flow adjust knob:  
when set at "0" no oil  
is delivered. Turn  
counter-clockwise for  
increased flow

Clockwise rotation  
increases regulated  
pressure

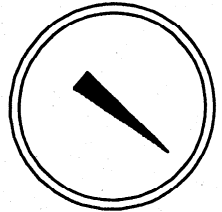

Recommended Pressure Setting:  
80-100 psi

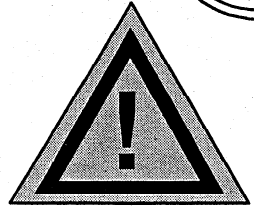

Warning:  
Do not set air  
pressure above 100 psi

## 4.4 Lubricator Adjustment

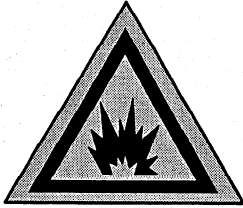

**Do not attempt to add oil to the lubricator while under pressure. Disconnect the air pressure supply and purge pressure from the system before filling with lubrication fluids.**

**The lubricator cannot be filled while under pressure.**

### **LUBRICATION:**

For average operating conditions, the use of SAE #10 (SUV > 150-200 SEC @100 degrees F) oil is recommended. Other lubrications may be used if not heavier than SAE #40 (SUV 800 SEC @ 100 degrees F).

### **FILLING:**

Shut down and depressurize before refilling lubricator. Slowly remove the fill plug and fill to 1/4 inch to the top of the bowl using recommended oil.

### **ADJUSTMENT:**

The adjustment knob is calibrated from "0" to "9". At "0" no oil is delivered, the unit is not lubricating. To adjust, first turn on the air. Turn the knob to start oil flow, observing the drip rate visible through the sight glass. One to two drops per minute is suggested, correct lubrication being a matter of experience and demand. *Counter-clockwise rotation of knob increases oil feed rate.*

To check lubrication, hold a mirror of similar material near the equipment exhaust. A heavy film discharge indicates over-lubrication. The oil drop rate should be reduced by turning the knob to a lower setting, decreasing oil drop rate.

If no oil drips through the sight glass with the needle valve open, proceed as follows:

- Make certain there is sufficient oil in the bowl.
- Check to determine whether there is air pressure ahead of the lubricator.
- Check the air flow from the lubricator.

If oil still does not drip through the sight glass, an accumulation of dirt in the lubricator is indicated. The lubricator will need to be cleaned.

## 4.5 Air regulator adjustment

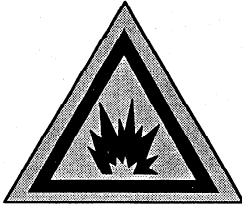

**It is recommended that air pressure remain between 80-100 psi**

**Never Keep pressure above 100 psi**

*Clockwise turning of the adjusting screw, (located under the regulator), increases the regulated pressure. Erratic regulator operation or loss of regulation is due most often to dirt in the disk area of the regulator, requiring disassembly and cleaning. To clean, turn-off air supply, and depressurize. Remove bottom plug, spring and disc. Clean all parts with denatured alcohol, wipe off seat, and blow-out regulator body with compressed air. Reassemble as a unit. Before tightening plug make sure disk is centered.*

## Chapter 5 Operation: Product packaging

### 5.1 Preparation

Before operating check all air connections. If they have become disconnected, reassemble as shown in the pneumatic schematic. Adjust incoming air to the recommended pressure of 80-100 PSI and check for any air leakage. If leakage is present, correct before continuing. Load clip spools, and push clips down rails and manually reset clip pusher. Check for proper feeding, and for any obstructions at the punch, knife, and die areas on the clipper.

### 5.2 Vacuum Nozzle Operation

**DANGER!** While operating machine, never place fingers near or through the slot in clipping area, or hands into or around the gate area. **SERIOUS INJURY MAY RESULT!**

- **MOVE** the nozzle assembly downward and into the package. Once the lip of the nozzle is securely within the package envelope, **PULL-DOWN** on the nozzle assembly, opening the valve to draw a vacuum against the package. After the vacuum is drawn proceed to the clipper.

## Chapter 5 continued:

### 5.3 Operating the Clipper

- Remove the nozzle, (release to close the valve), and quickly slide the package into the slot of the clipper's die support. As the package tail reaches the bottom of the slot, it activates the trigger arm, activating the punch valve. The clipper goes through its cycle.
- The punch advances into the die forming a clip onto the product.

### 5.4 Cut-off Knife Operation

- Once the correct pressure is reached, the air pressure continues to the cut-off knife cylinder, extending the knife.
- After the cut-off knife fully extends and cuts the package between the two clips, start to remove the product. The trigger valve resets, retracting the cut-off knife and clip punch.
- Continue to remove the package out of the clipper by pulling the material away from the side of the die support plate.
- System resets, machine is ready for another cycle.



#### **Warning!**

If a clip jams in the die area, do not attempt to cycle the machine again until the jam is cleared. Follow all safety procedures as described in Section 2.2, entitled Safety Instructions. Disconnect air supply prior to servicing or moving the machine. The main air supply line must be disconnected from the machine before performing any service operation or maintenance.

After disconnecting the air supply, lock-out the air supply valve before attempting to remove the clip, or other obstructions from the die area. Failure to do this creates serious risk of injury to the operator.

## 5.5 Operating features

### Clipping Sequence

- A) Push product into throat of Die support.
- B) Activate the punch trigger valve.
- C) Punch trigger valve activates.
- D) Punch assembly starts downward, clip is taken from rail. At the bottom of the stroke, clip forms onto product in die.
- E) At end of punch stroke, cut-off knife extends and cuts product between the two clips.
- F) Valve resets system. knife and punch retract.
- G) Remove product. Machine is ready for another cycle.

### Vacuum Nozzle assembly

Pull down on the handle to open the vacuum nozzle

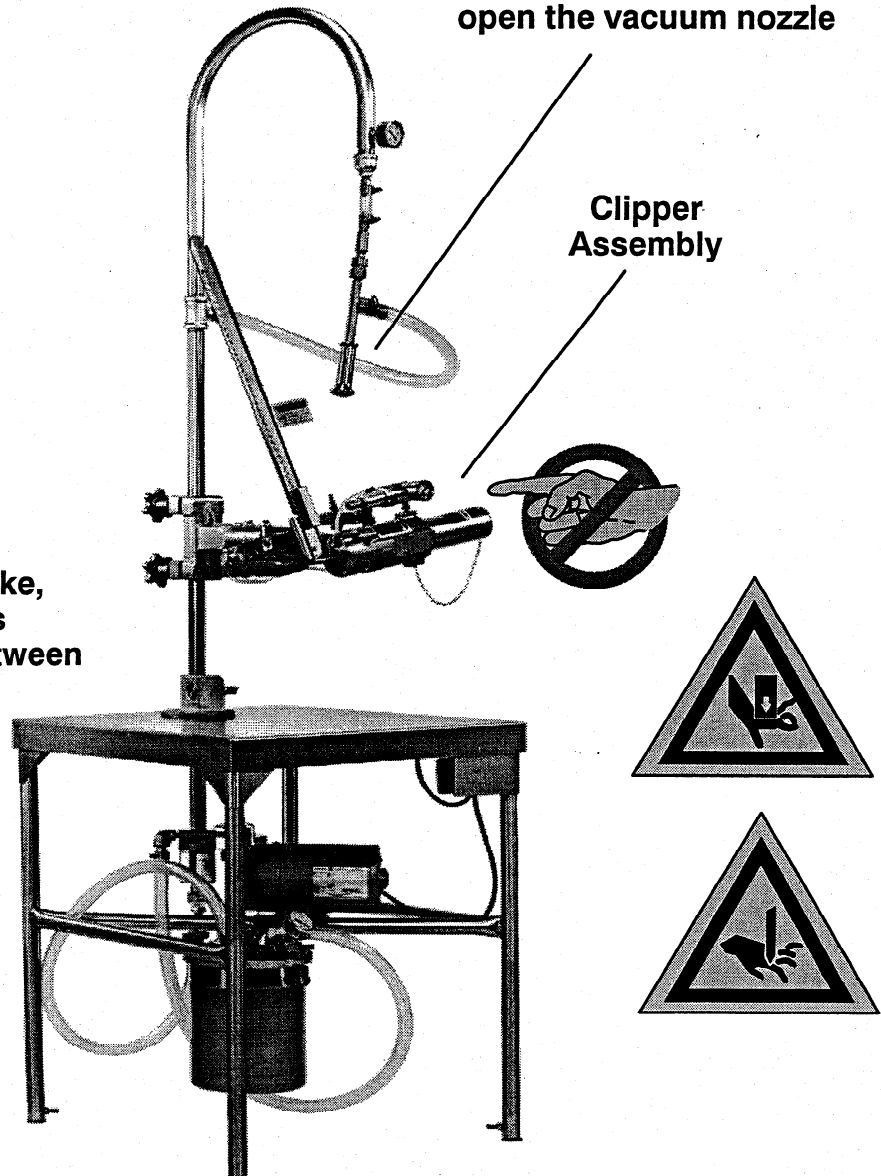

## **Chapter 6: Cleaning Procedure**

### **6.1 U.S. Department of Agriculture Guidelines**

**APPROVED CLEANING COMPOUNDS:  
U.S. DEPARTMENT OF AGRICULTURE  
FOOD SAFETY AND INSPECTION SERVICE  
(REFERENCE AGRICULTURE HANDBOOK NO. 562)**

This publication is intended to assist in applying approved cleaning methods under the USDA meat and inspection program. Cleaning materials used must be in compliance with the USDA. Compliance with the requirements set forth in the publication does not, in itself constitute authorization. Users must submit application with the USDA for consideration of suitability of preparations and their safety for use as directed.

#### **Submit requests for such evaluation to :**

Compounds Evaluation Unit, CPS  
Product Safety Branch  
Food Ingredient Assessment Division, Science, FSQS  
U.S. Department of Agriculture  
Building 396, Room 300, Barc-East  
Beltsville, MD 20705  
Tel (301) 344-2566

**U.S. Department of Agriculture Food Safety and Inspection Service  
Handbook No. 562 Part 5, Section 5.1 Cleaning Compound**

**(A) GENERAL USE CRITERIA**

- (1) Neutral or mildly alkaline preparations consisting of any combination of soaps, detergents, wetting agents, emulsifiers, solubilizers, and common inorganic builders may be used on any surface in and department
- (2) Strongly alkaline preparations (those containing in excess of 20 percent caustic soda or other ingredients with the equivalent causticity thereof) may be used only in soak tanks or with steam or mechanical cleaning devices in any department
- (3) Acidic preparations consisting of mineral acids, organic acids, or acidic salts may be used in any department for the removal of rust, corrosion, scale, or other deposits which are not readily removed by alkaline preparations.

**(B) RESTRICTIONS OF USE**

- (1) Before using any cleaning preparation, food products and packaging materials must be removed from the room or carefully protected. After using such preparations, all surfaces must be thoroughly rinsed with potable water.
- (2) Preparations having a characteristic odor of fragrance as diluted for use may, in the opinion of the USDA, interfere with sanitary inspection of food contact surfaces may not be used on food contact surfaces. They may be authorized for limited use on floors and walls only.
- (3) Preparations containing abrasive materials such as silica, pumice, etc. may be used on food contact surfaces only if care is taken to remove all odors or residues resulting from their use by thorough rinsing with potable water.
- (4) Boric acid and salts thereof, may be used in such preparations only at concentrations up to 90 percent in association with strong acids, strong alkalis, soaps, or synthetic detergents.

## **6.2 Cleaning procedure**

After use, the machine must be cleaned to remove all residues (food products). Check and clean the throat, punch, knife and die areas of the clipper, vacuum nozzle and table top, (*food contact zones*). Also check all other machine surfaces and surrounding work station for material residues or contamination. All surfaces must be cleaned using the recommended materials and procedures as outlined by the U.S. Department of Agriculture Food and Inspection Service Handbook No. 562. A copy of Part 5, Section 5.1, Titled: Cleaning Compounds: is included with this manual. Cleaning product approval, in writing is required, as outlined in the copy provided.

Remember, before cleaning, ensure that the air supply has been disconnected from the machine, and all lock-out procedures have been followed.

### **Never attempt to clean the clipper while it is attached to the air supply!**

- Turn off factory air and disconnect the air line with the "Quick disconnect", and follow all lock-out procedures.
- Remove all guards to expose all surfaces for cleaning.
- Clean all surfaces as outlined by the U.S. Department of Agriculture Handbook.
- After cleaning, (FDA food contact approved) light mineral should be applied to all pivot areas. The internal moving parts are lubricated by the filter / regulator / lubricator.
- After cleaning and lubricating, reassemble all guards and check for safe function. Check for and tighten all loose connections and screws before returning machine to operation. Check for and remove all burrs around die pocket.
- While cleaning the clipper, inspect for worn or damaged components needing replacement. For replacement parts refer to the list of recommended spare parts, and assembly drawing.

## **Chapter 7: Maintenance**

### **7.1 General Maintenance Checklist**

- Check regularly for loose screws.
- Check the oil level in the lubricator regularly
- Check the air filter on a regular basis
- Check the knife for signs of chipping
- Check the end of the punch for burrs
- Check guards for safe function

Check for and tighten all loose connections and screws before returning machine to operation. Check for and remove any burrs around die pockets.

While cleaning the clipper, inspect for worn or damaged components needing replacement. For replacement parts refer to the list or recommended spare parts and assembly drawings.

## **7.2 Lubricator Maintenance**

The oil level in the lubricator must never be allowed to drop below the end of the dip tube. To replenish oil, first shut off the air supply, lock-out the system. Remove the slotted filler plug and fill to oil level mark. Replace and tighten plug.

Normally, the lubricator should require only occasional cleaning, provided clean oil is used, and the air supply is kept clean by the filter system. However, if no oil drips through the sight glass, and the oil supply has been replenished, the lubricator requires cleaning.

*Check the following before cleaning the lubricator:*

- Make sure there is sufficient oil in the bowl.
- Check to determine whether there is air pressure ahead of the lubricator
- Check the air flow from the lubricator

If each of these areas are functioning properly, continue to clean the lubricator.

## **7.3 Filter / Regulator / Maintenance**

The air filter is equipped with an automatic drain that should be cleaned periodically to maintain maximum filter efficiency. Open drain cock under the filter periodically and drain off any bowl accumulation before it reaches level of the lower baffle. A visible coating of dirt on the filter element surface or an excessive pressure drop in an indication that cleaning is necessary.

To clean the filter, turn off air supply, lock out system, and depressurize. Loosen locking collar and remove bowl. Clean all parts with denatured alcohol and blow out the inside with compressed air.

To clean the regulator, turn off air supply, lock out system, and depressurize. Remove the bottom plug, spring, and disk. Clean all parts with denatured alcohol. Wipe off seat and blow out regulator body with compressed air. Reassemble the filter / regulator unit. Before tightening the plug, make certain the disk is centered.

After cleaning and servicing, the air regulator may need adjusting. Adjust the incoming air to the recommended pressure settings of 80-100 psi, (5,5-6,9 bar). Always keep air pressure below 100 psi, (6,9 bar).

Always check the air muffler for oil build up and blockage. A muffler caked with oil or accumulated contamination will restrict the porting of the used air into the atmosphere, and slow down the machine. Always check the mufflers when servicing the filter / regulator unit, and replace as required.

## 7.4 Vacuum pump

The **TIPPER TIE CVE** uses the GAST 3/4 HP Single stage rotary vacuum pump.

### 7.4.1 Electrical requirements: (vacuum pump)

#### Model 0823

HP	3/4	Hz 60/50
Volts	100-115/208-230	PH 1
RPM	1725/1425	code J
A	12.2/6.1	SF 1.00
SFA	AMB 40 c	

<b>TIME RATING:</b>	Cont
	50 Hz
	100-110/220-240 V
	14.0/ 7.0 AMPS

All electrical connections should be made by qualified, competent electricians in accordance with all local and national codes.

### 7.4.2 Lubrication system: (Vacuum pump)

The pump uses a constant level oiler. The lubrication rate is determined by the temperature, the vacuum or pressure at which the pump is operating, and the siphon jar oil level (determined by the vertical position of the tube in the jar).

Before operating the machine, check the vacuum pump for operating oils. To replenish, pull the reservoir upward out of the adjusting sleeve and turn over. Add oil through the tube. When the upper reservoir is filled, replace it through the adjusting sleeve and firmly seat it against the top of the sleeve. The oil wick should be folded in half, with the two ends submerged in the oil at the bottom of the jar. The folded center of the wick is inserted into the connector approximately 3/8" (9,5 mm) past the two breather holes in the connector, it should not touch the feed hole leading to the pump. Both the breather holes and the feed hole must be unrestricted.

The lower end of the tube should be 1/4" ( 6,35 mm) from the bottom of the oil jar for normal lubrication. To reposition the tube, loosen the locknut and adjust the sleeve up or down.

Lock the new position with the locknut. For faster lubrication, raise the reservoir tube away from the bottom of the oil jar. For slower lubrication, lower the reservoir tube toward the bottom of the jar.

Upon starting vacuum pump, check for vacuum leaks around all hose connections. Refer to the GAST Operation and Maintenance technical manual for additional information and trouble shooting guide.

### 7.4.3 Oil type

Oil type, GAST recommended oil part No. AD220. 10wt. high detergent automotive engine oil can also be used, as an equivalent. In high ambient locations a 20wt. oil may also be used.

### 7.4.4 Motor

If the motor fails to start or slows down under load, shut off and unplug. Check the supply voltage agrees with the motor post termination and the motor data nameplate. Also examine plug and switch. If unit is extremely cold, bring to room temperature before starting.

### 7.4.5 Flushing

Most pump troubles can be corrected by flushing rather than be taking apart. A noisy or inefficient pump is frequently nothing more serious than a vane(s) stuck in the rotor slot due to excessive oiling or foreign material in unit. Remove inlet and outlet accessories. Add several teaspoons of solvent, (recommended solvent, Gast Flushing solvent part No. AH255) slowly at the intake while unit is running. Flush unit in a well ventilated area. Eye protection is recommended. keep face away from exhaust port and do no flush unit with flammable solvent. lay unit on side with outlet downward so solvent will work out again. Right the pump. Add a few drops of oil at intake and attach accessories.

### 7.4.6 Disassembly

If foreign matter has entered pump, try flushing. If this does not eliminate the foreign matter, remove only the end plate and the four vanes, (DO NOT at any time remove the rotor or loosen any of the electric motor thru-bolts). Wash vanes, end plate, and pump chamber with recommended solvent. Dry and re-lubricate lightly. If the pump fails to produce the proper vacuum or pressure, the top clearance between the rotor body may have increased. A metallic clanging could mean the rotor and the body are touching. Remove end plate, loosen body bolts; and set top clearance at .004. This can be done by tapping LIGHTLY with a miniature hammer on pump body, (either top or bottom, depending whether clearance is too large or too small). The rotor should be turning while setting clearance so that all points on the circumference of rotor will clear. End clearance, total for both sides of rotor may vary from .0025 to .0035 inch.

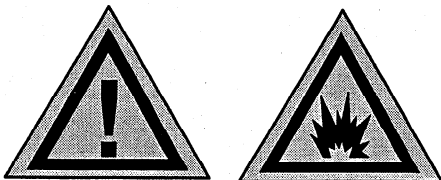

#### **Warning:**

Do not use kerosene, gasoline or any other flammable liquid for flushing. Personal injury and /or property damage will result.

## Chapter 8: Trouble Shooting Guide

### **Symptoms**

### **Solution**

***Clipper has no power***

- Air connection may be loose. Check all air connections.
- or Regulator may be turned off. Check the regulator unit.
- or Water may be in the system. Drain and change the filter.

***Clipper is slow***

- Water may be in the system. Drain the water and change the filter.
- or Muffler may be clogged. Replace the muffler.
- or Pressure to the clipper is low. Check the pressure setting and increase if necessary.
- or Air lines are pinched. Replace the air lines.
- or Cylinder is stuck. First check for pinched air line and check the air pressure. If cylinder is still stuck, disconnect air line and check for broken or worn parts. Replace bad parts or air cylinder.

***Punch does not retract***

Knife blade housing may be jammed with product residue. Disassemble and clean.

***Knife does not cut***

Check knife for nicks and sharpen as needed.

***Malformed clips***

- Punch or die may be damaged. Replace as necessary.
- or Air pressure may be too low or too high. Check air pressure and adjust if necessary.

***Clips are loose and seal poorly***

- Check crimp control and adjust if needed.
- or Air pressure is too low. Check air pressure and adjust if necessary.
- or Punch and die may be worn down. Check for wear on punch and die, and replace if needed.

## Chapter 9: Replacement or Spare parts

When ordering replacement or spare parts, always include the following:

**Machine model number and date of purchase:**

**Identifying part numbers stamped on part:**

**Part number or numbers on spare parts list,  
or identifying item numbers on assembly drawings:**

### 9.1 Loose Parts List

Item	Part No.	Description	Qty.
1	24-9930	White oil (ISO VG32 Equivalent)	1
2	00-0915	Air Supply Unit	1
3	80-0005	Model Operators Manual	1

## Chapter 10: Assembly Drawings

CV-E	Assembly
00-0803	Waste tank
00-0805	Shut-Off valve assembly
00-0813	Goose neck pipe assembly
00-1368	Intake Filter assembly
00-1369	Exhaust muffler assembly
00-4153	Waste tank assembly
00-4526	ON/OFF switch assembly
00-4527	Lubrication assembly
00-5952	3/4 HP Vacuum motor assembly
00-8065	Vacuum nozzle assembly
00-8103	Pipe adapter assembly
27-1016	Vacuum pump

### Options

00-0424	Spit nozzle assembly
00-8066	Vacuum nozzle assembly
00-0915	Air supply unit
00-0397	Pipe adapter assembly
00-0783	Pipe adapter assembly

### Gas Flush Options

00-5325	Vacuum Nozzle assembly
00-5359	Gas Flush Valve assembly
00-5363	Waste tank cover assembly
00-5364	CV-E Gas Flush conversion Kit

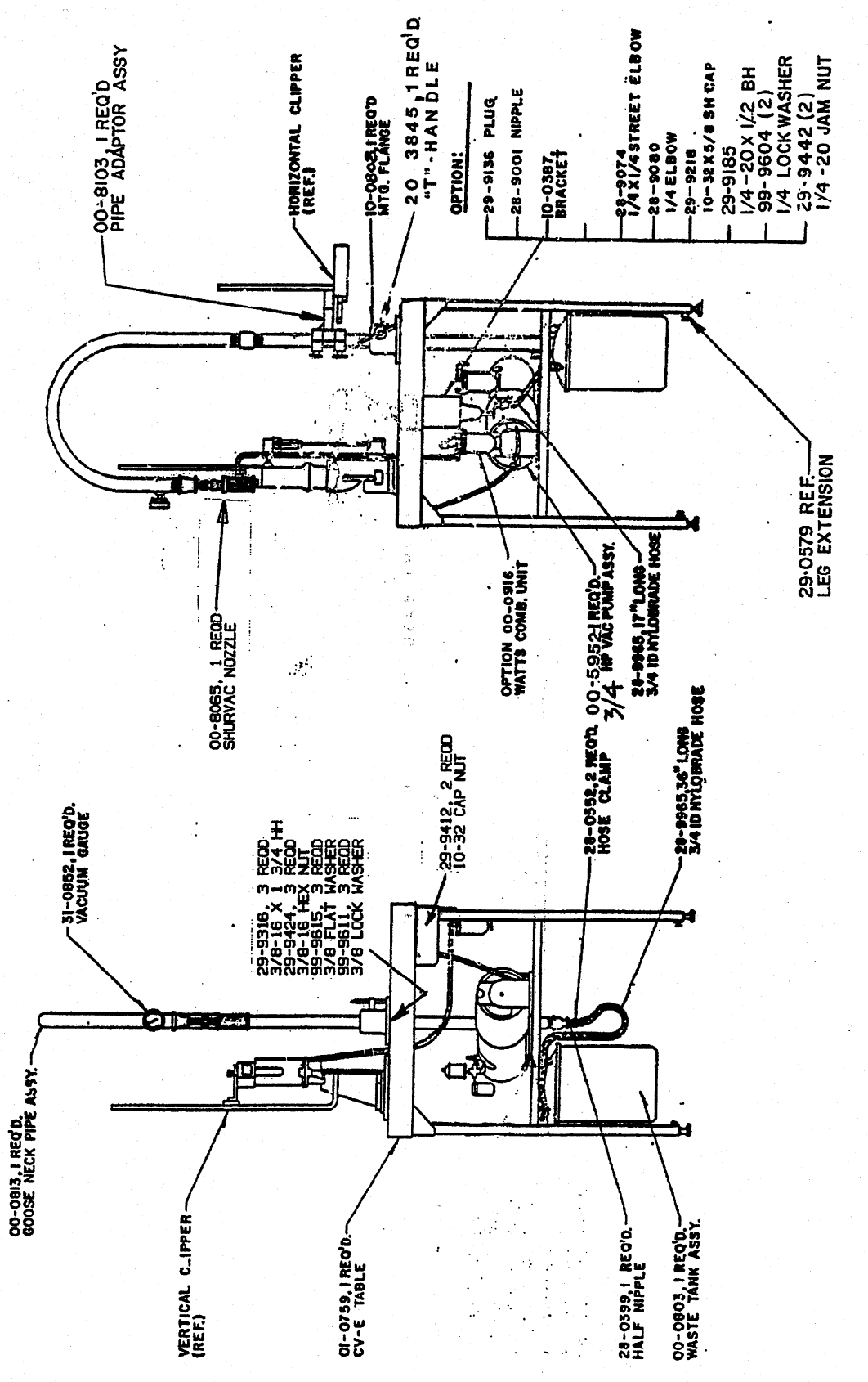

M89

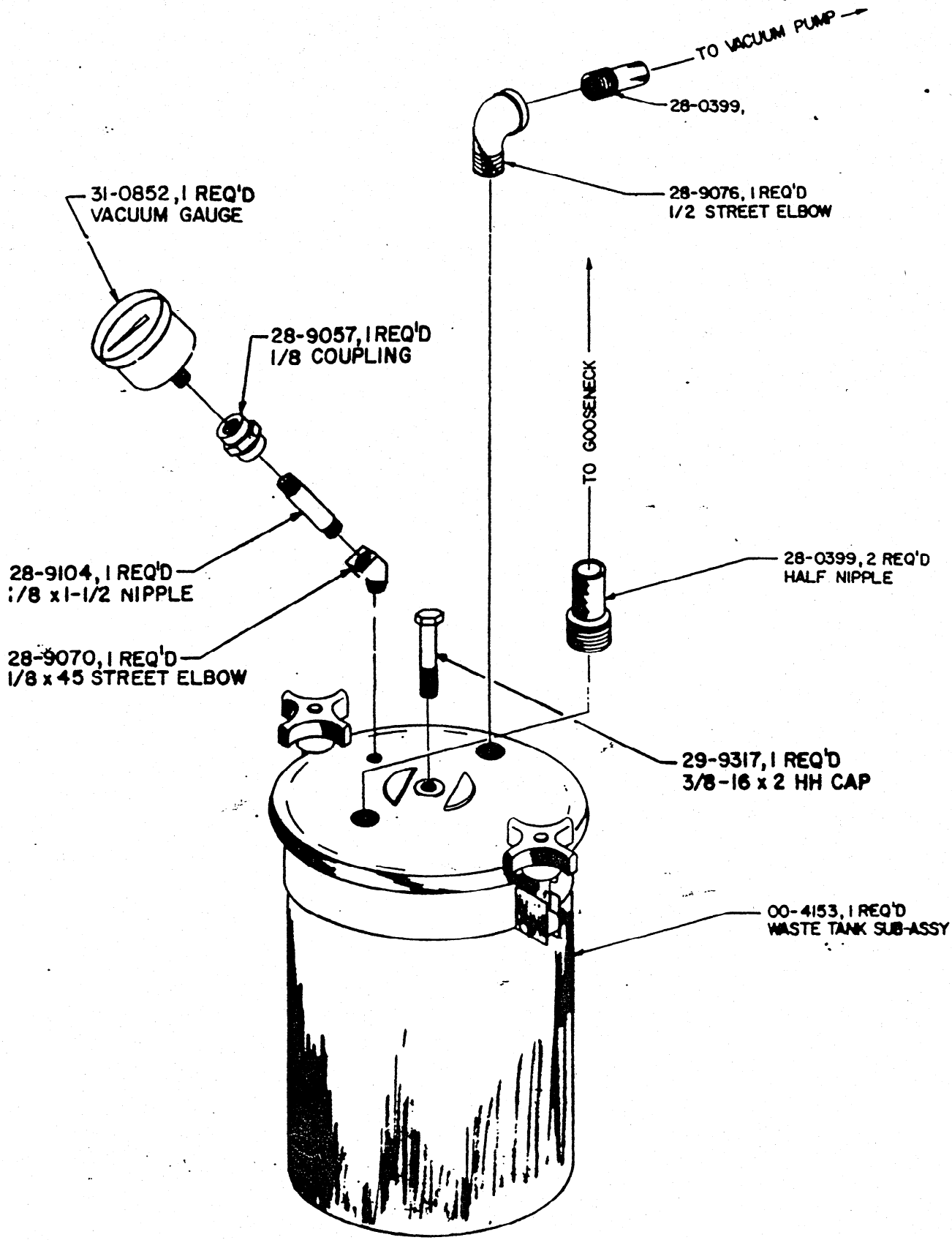

31-0852, 1 REQ'D  
VACUUM GAUGE

28-9057, 1 REQ'D  
1/8 COUPLING

28-9104, 1 REQ'D  
1/8 x 1-1/2 NIPPLE

28-9070, 1 REQ'D  
1/8 x 45 STREET ELBOW

28-0399,

28-9076, 1 REQ'D  
1/2 STREET ELBOW

TO GOOSENECK

28-0399, 2 REQ'D  
HALF NIPPLE

29-9317, 1 REQ'D  
3/8-16 x 2 HH CAP

00-4153, 1 REQ'D  
WASTE TANK SUB-ASSY

WASTE TANK ASSEMBLY

00-0803-04

3-12-87

USED ON  
00-4153

99-0848 | REQ'D  
BALL

99-0769 | REQ'D  
FILTER

41-0849 | REQ'D  
1/2" CUP

99-0768 | REQ'D  
CONNECTOR

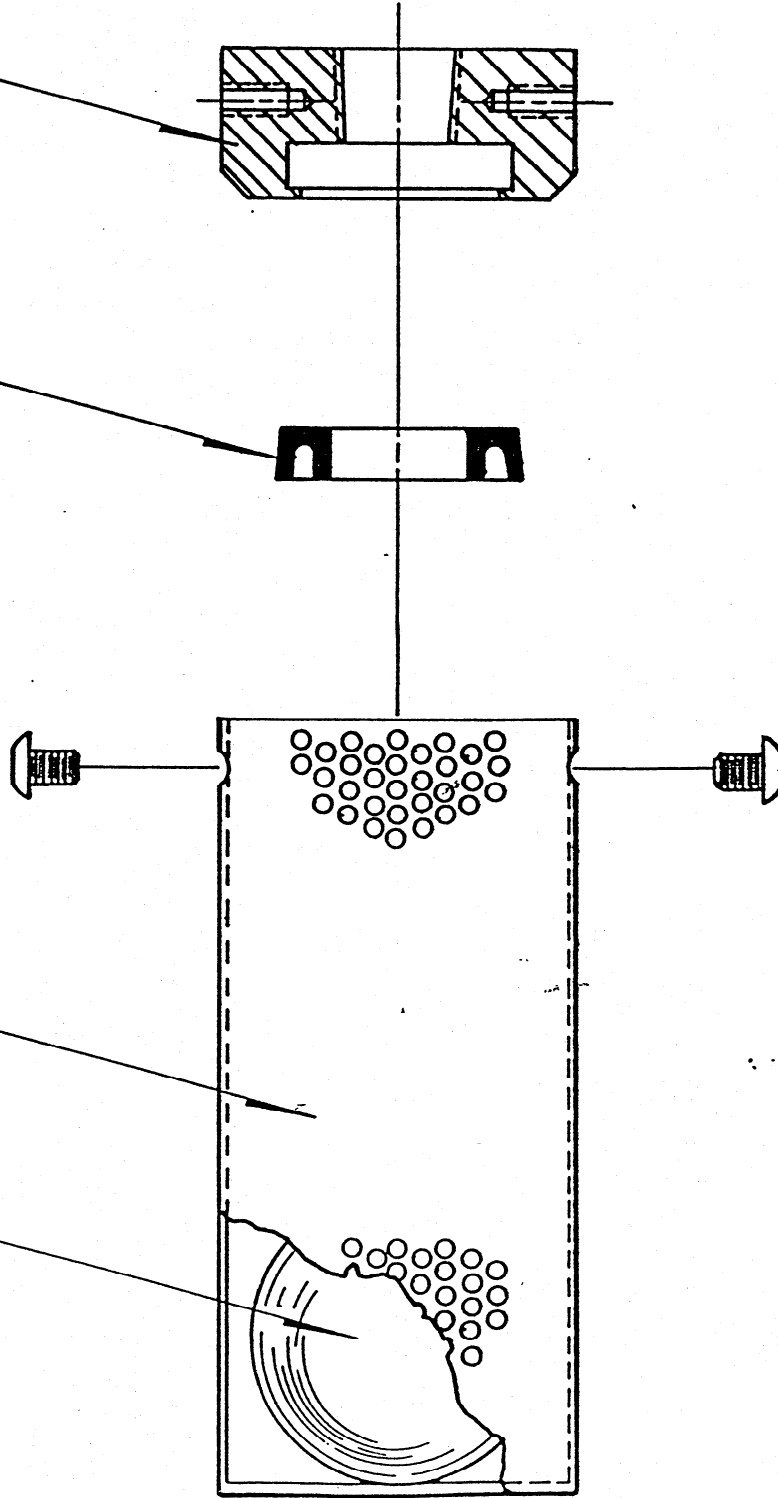

29-9179 2 REQ'D  
10 32 X 1/4 BH

SHUT-OFF VALVE ASSY  
00-0805 8-11-75

REV. 1

USED ON  
CV-E

28-0844, 1 REQD.  
BELL REDUCER  
(USE 28-1001  
& 28-1002)

28-0840, 1 REQD.  
PIPE, CURVED SECTION

99-0728, 2 REQ'D.  
BARB FITTING

28-9962, 6" REQ'D.  
1/2 ID NYLOBRAID  
HOSE

28-1253, 1 REQD.  
COUPLING

28-0928, 2 REQ'D.  
HOSE CLAMP

28-9965, 1 REQD.  
3/4 NYLOBRADE HOSE

28-1258, 1 REQD.  
TEE

28-0552, 2 REQD.  
HOSE CLAMP

28-0841, 1 REQD.  
PIPE, STRAIGHT  
SECTION

28-0399, 1 REQD.  
HALF NIPPLE

28-0843, 1 REQD.  
BELL REDUCER

REV.04

GOOSE NECK PIPE ASSEMBLY  
00-0813 11-11-77

MSP

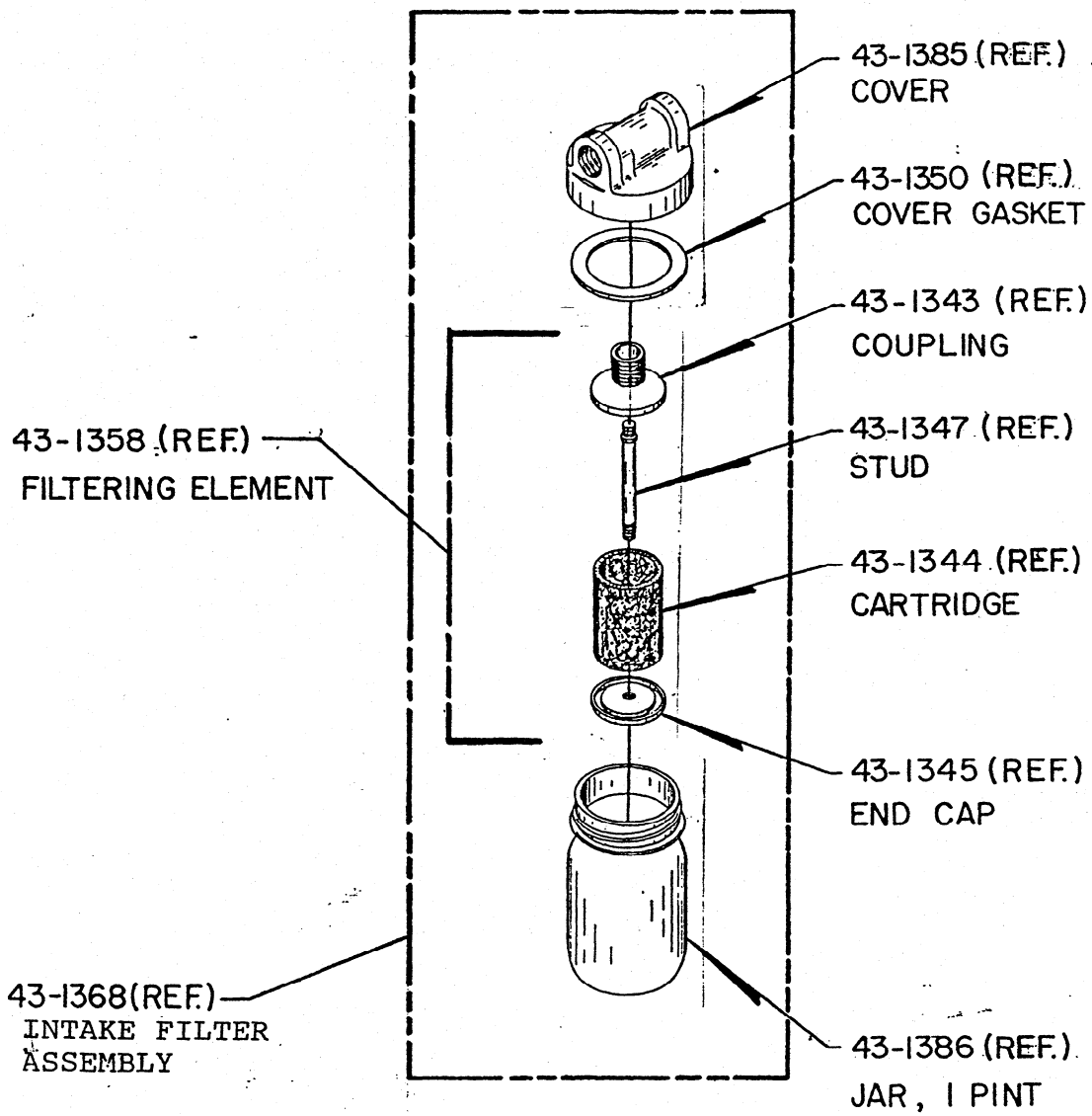

# REVISIONS

NO.	DESCRIPTION	DATE	APPROVED	NO.	DESCRIPTION	DATE	APPROVED

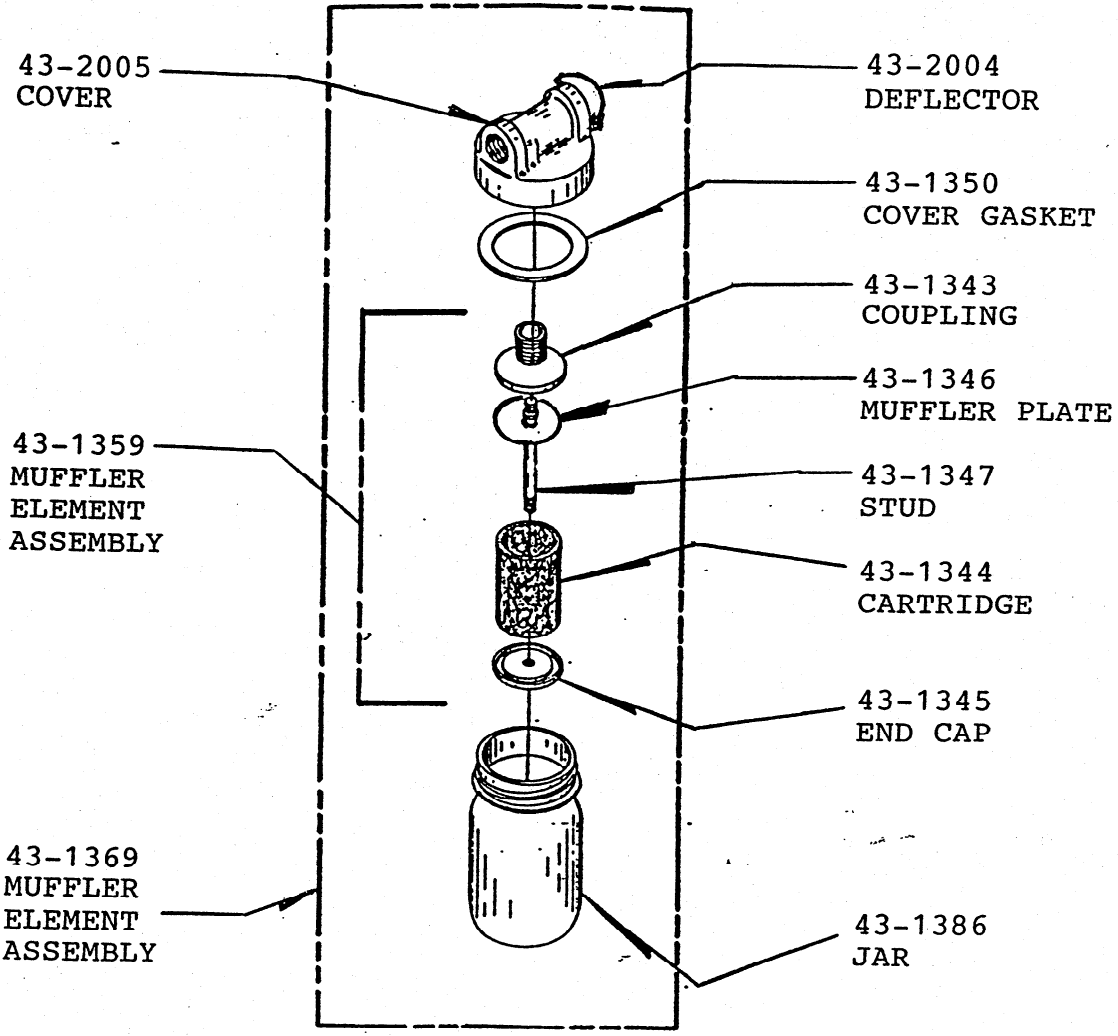

 <b>TIPPER TIE</b> <small>A DOVER INDUSTRIES COMPANY</small>	CHECKED BY	DATE	EXHAUST MUFFLER ASSEMBLY		
	<i>DM</i>	<i>6-20-94</i>			
DRAWN BY	APPROVED BY	DATE	SIZE	CLIPPER VAC'S	PART NO.
	<i>JOM</i>	<i>6/20/94</i>	<b>A</b>		00-1369-00
DATE	RELEASED BY	DATE	SCALE	DO NOT SCALE DRAWING	SHEET 1 of 1
<i>6-20-94</i>	<i>JOM</i>	<i>6/20/94</i>	N/A		

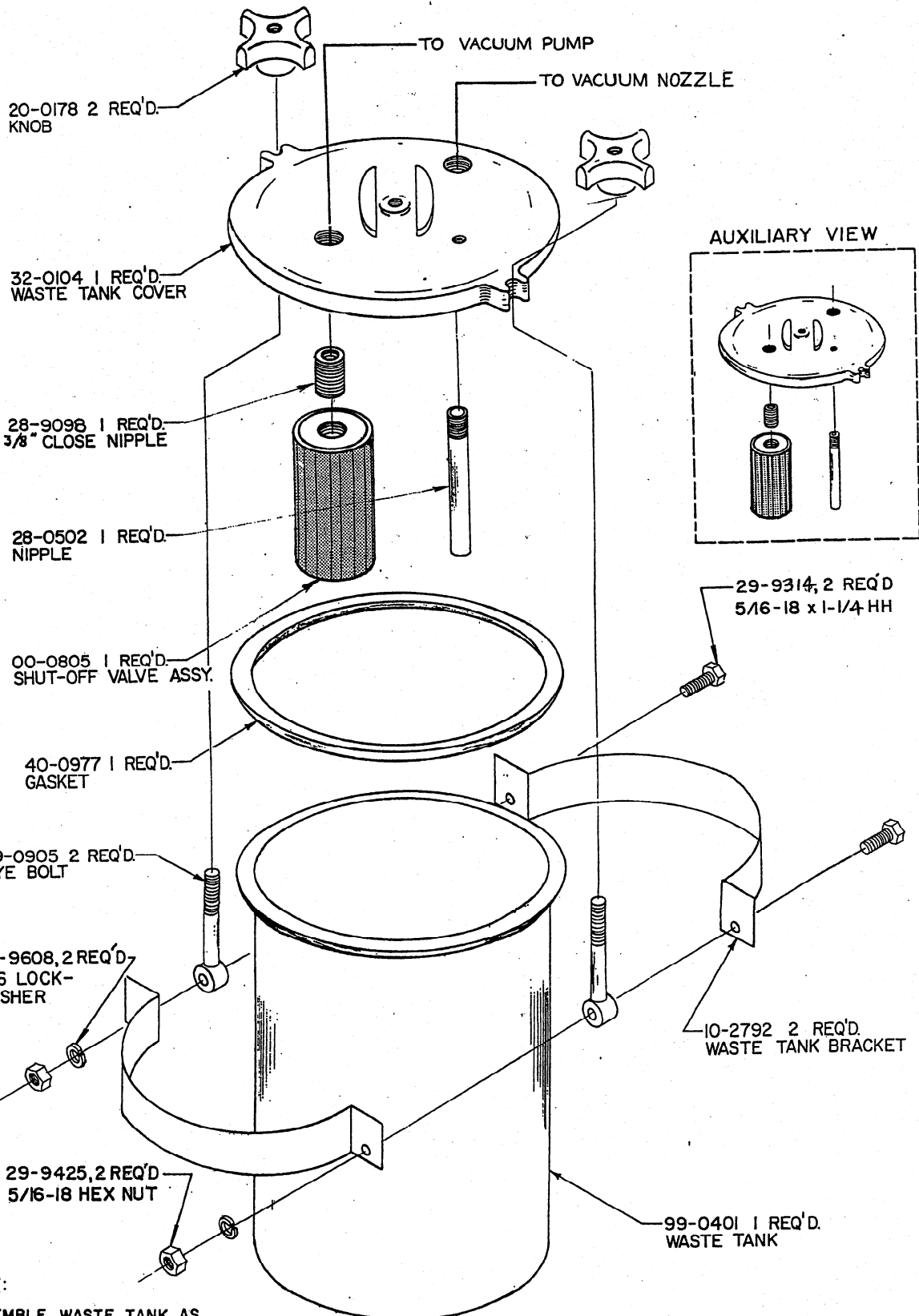

**NOTE:**

ASSEMBLE WASTE TANK AS SHOWN IN AUXILIARY VIEW FOR USE ON RIGHT HAND CLIPPER VAC CABINETS.

**WASTE TANK ASSEMBLY**

USED ON  
 00-4520  
 00-0998  
 00-1424  
 00-5952

30-9954, 1 REQ'D.  
 17CM50 COVER

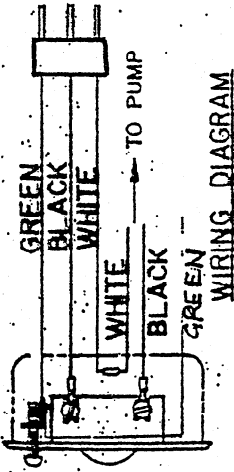

30-9952, 2 REQ'D.  
 4X308 RING CONNECTOR  
 30-9953, 1 REQ'D.  
 4X313 BUTT CONNECTOR  
 30-9958, 2 REQ'D.  
 4X299 SPADE CONNECTOR  
 30-9956, 2 REQ'D.  
 T & B CORD GRIP

ROTATE 180° TO  
 INSTALL SWITCH  
 FROM PICTURE  
 SHOWN.

30-9955, 1 REQ'D.  
 HANDY SWITCH BOX

Mounting Hardware  
 29-9182, 2 REQ'D.  
 10-32 x 5/8 BH  
 29-9421, 4 REQ'D.  
 10-32 HEX NUT  
 99-9603, 4 REQ'D.  
 #10 INT/T LOCKWASHER

30-9944, 2 REQ'D.  
 1/4 FEMALE QUICK DISC.  
 30-9951, 28 IN. REQ'D.  
 16/3 ELECTRIC CORD

WARNING! THIS MUST BE PLUGGED INTO A GROUND FAULT CIRCUIT INTERRUPTOR (GFCI) TYPE RECEPTACLE. FAILURE TO DO SO COULD CAUSE INJURY OR DEATH.

30-0246 (9')  
 14/3 ELECTRIC CORD  
 ON-OFF SWITCH ASSEMBLY  
 00-4526-08 3.5.87

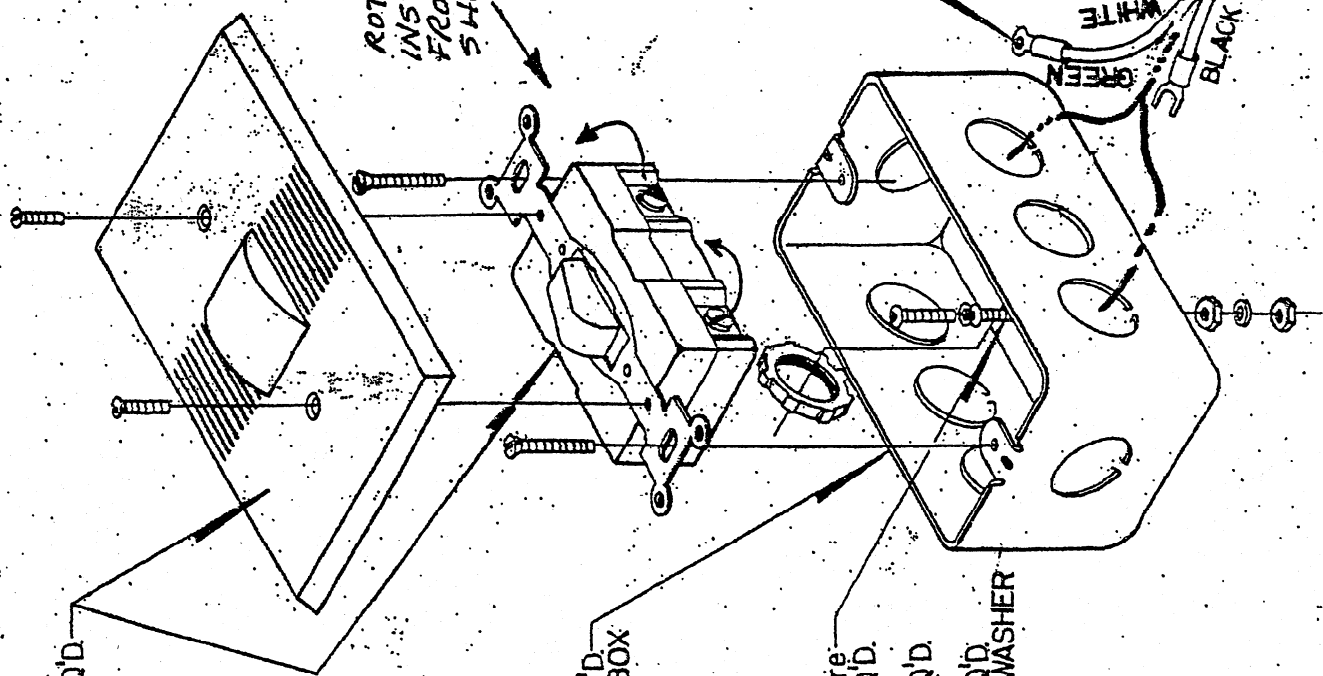

USED ON  
00-7983

43-1314 1 REQ'D.  
OIL. RESERVOIR

43-1302 1 REQ'D.  
ADJUSTABLE SLEEVE

43-1303 1 REQ'D.  
LOCK NUT

43-1316 1 REQ'D.  
CONSTANT LEVEL OILER

43-1301 REF  
COVER

43-1394 REF  
CONNECTOR

43-1391 REF  
COVER GASKET

43-1392 REF  
WICK

43-1393 REF  
JAR

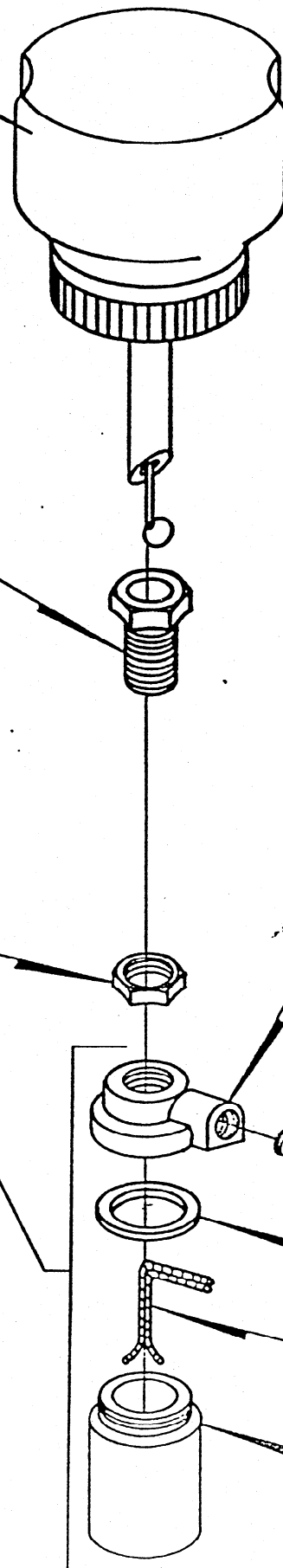

REV.

LUBRICATION UNIT  
00-4527 3-13-87

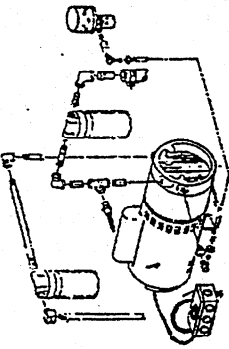

ASSEMBLE AS SHOWN ABOVE FOR RIGHT HAND CLIPPERS. PARTS IDENTICAL.

43-1369, REF. FILTER EXHAUST MUFFLER (FOR PARTS, SEE 00-1369)

WARNING: THIS MUST BE PLUGGED IN A GROUND FAULT CIRCUIT INTERRUPTOR (GFCI) TYPE RECEPTACLE. FAILURE TO DO SO COULD CAUSE INJURY OR DEATH.

43-1389, 1 REQ'D. VACUUM REGULATOR

28-9129 3/8-8 GALV. NIPPLE 1 REQ'D

28-9149, 1 REQ'D. 3/8 GALV. TEE

28-0399, 1 REQ'D. HALF NIPPLE

28-9085, 1 REQ'D. 3/8 x 1/2 GALV. ELBOW

28-9093, 4 REQ'D. 3/8 x 3/8 HEX NIPPLE

28-9126, 1 REQ'D. 3/8 x 6 NIPPLE

43-1368

28-9089, 2 REQ'D. 3/8 GALV. ELBOW

28-9089

INTAKE FILTER ASSEMBLY (FOR PARTS SEE 00-1368)

00-4528, (REF) LUBRICATION UNIT

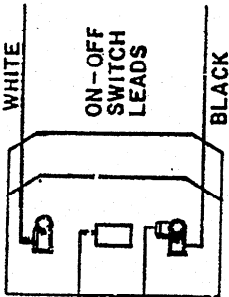

WIRING SCHEMATIC

BLUE REF.  
YELLOW REF.

WHITE  
ON-OFF SWITCH LEADS  
BLACK

28-9045, 2 REQ'D. ELBOW FITTING  
28-9043, REF. COMPRESSION SLEEVE  
28-9042, REF. COMPRESSION NUT  
28-9018, REF. HOSE INSERT

28-9966, 2 FT. REQ'D. 1/4 OD POLY-FLO TUBING

28-9965, 3 FT. REQ'D. 3/4 ID NYLOBRAD HOSE

28-0552, 2 REQ'D. HOSE CLAMP

30-0009, 1 REQ'D. CORD GRIP  
30-0031, 1 REQ'D. LOCK RING

28-9045  
28-9043  
28-9042

00-4526, 1 REQ'D. ON-OFF SWITCH ASSY.

28-9018  
99-9609

29-9305 2 REQ'D. 5/16-18 x 1 HH

10-0899 (REF.)

99-9609, 6 REQ'D. 5/16 FLATWASHER

29-9402, 6 REQ'D. 5/16-18 x 1/2 SST. HH

27-1016, 1 REQ'D. 3/4 HP VAC PUMP

28-9093

3/4 HP VAC. PUMP ASSY.  
00-5952-07 3-18-87

USED ON  
CV-E

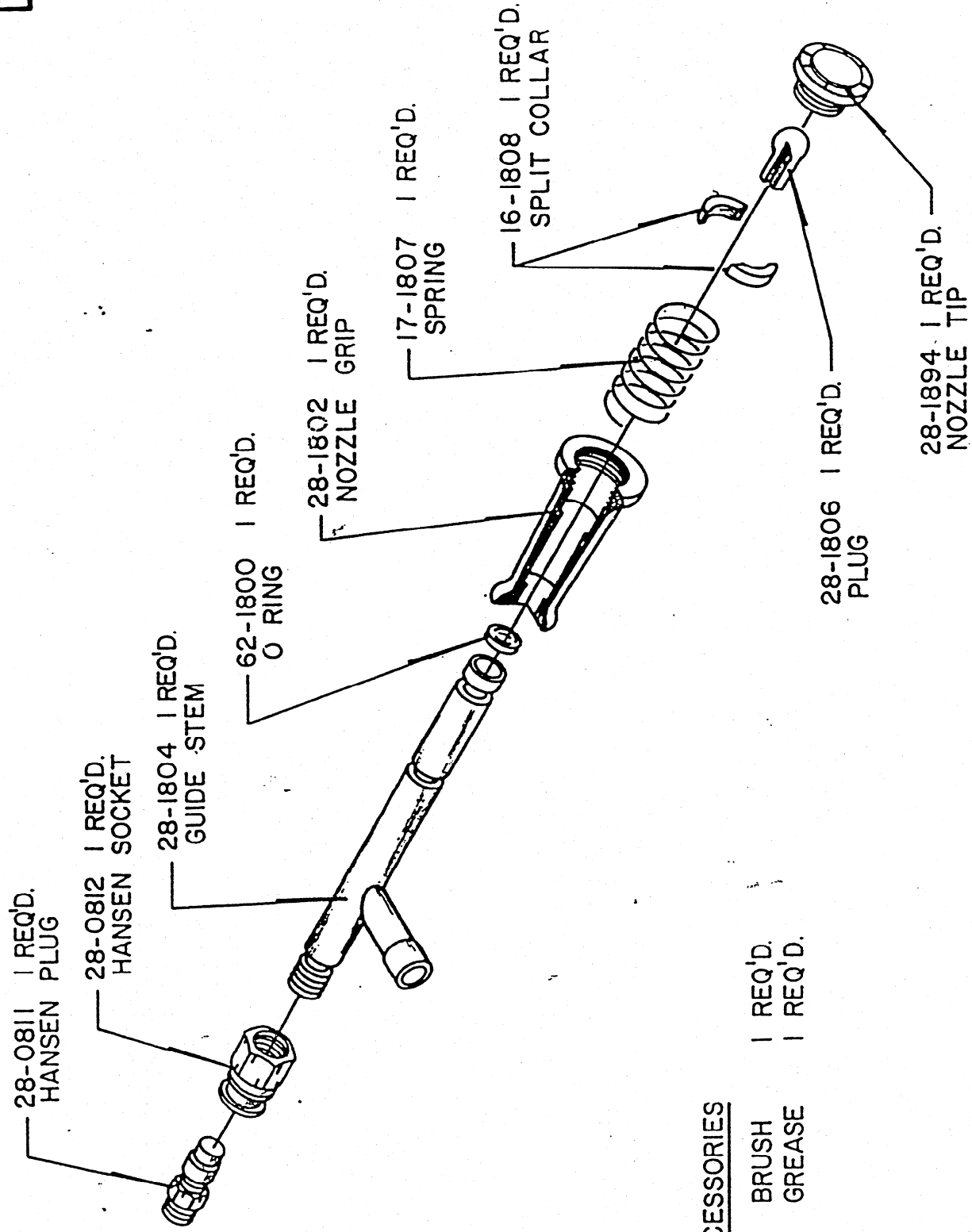

ACCESSORIES

- 99-1821 BRUSH 1 REQ'D.
- 99-1822 GREASE 1 REQ'D.

VACUUM NOZZLE ASSEMBLY  
00-8065 4-5-77

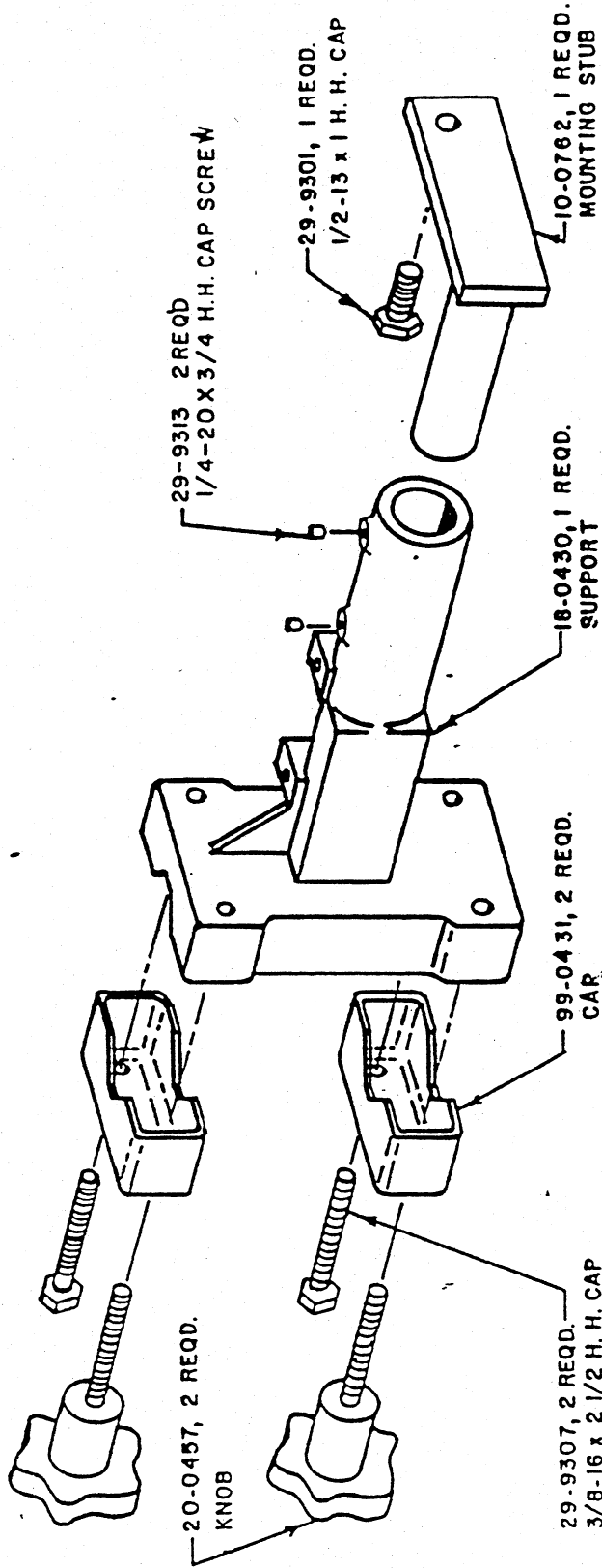

PIPE ADAPTER ASSY,  
 00-8103-01 02-08-82

## REVISIONS

NO.	DESCRIPTION	DATE	APPROVED	NO.	DESCRIPTION	DATE	APPROVED
				05	PCN 950025	2/15	<i>DM</i>
				04	PCN 940350	12/7	<i>DM</i>
				03	RE-DRAWN/PCN 940168	6/94	<i>DM</i>

A SUBSTITUTE ITEM SHALL NOT BE USED WITHOUT PRIOR TESTING AND APPROVAL BY ENGINEERING

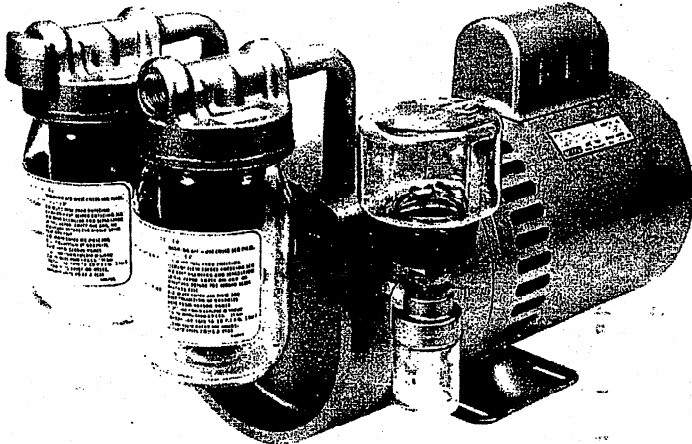

**MODEL 0823 SERIES**  
26.5" HG MAX. VAC., 8.0 CFM OPEN FLOW

### PRODUCT FEATURES

- Lubricated operation
- Motor mounted
- Rugged construction/low maintenance
- Essentially pulse free service

### INCLUDES (ALL MODELS)

- Constant level oiler AD125K
- Oil reservoir AD117
- Filter AB599
- Muffler AB599C
- Thermotector (single phase units only)

### COMMON MOTOR OPTIONS AVAILABLE

- 115V, 60 Hz, single phase
- 220V, 50 Hz, single phase
- 230V, 60 Hz, single phase
- 110/220V, 50 Hz, single phase
- 115/230V, 60 Hz, single phase
- 208-220/440V, 50/60 Hz, three phase

### RECOMMENDED ACCESSORIES

- Vacuum relief valve AA840A
- Vacuum gauge AA640
- Repair kit K486

### Important Notice:

Pictorial and dimensional data is subject to change without notice.

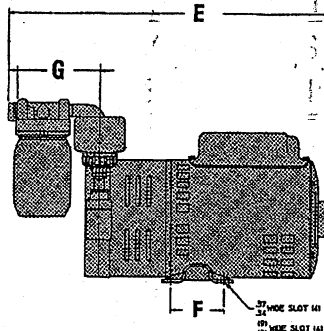
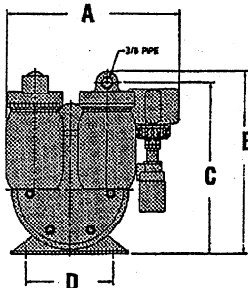

Model 0823/1023

### Product Dimensions Metric (mm) U.S. Imperial (inches)

Model	A	B	C	D	E	F	G
0823	243	255	239	124	471	76	131
0823	9.58	10.02	9.39	4.88	18.54	3.00	5.17

**Note:** Revision 03 of this drawing changed the pump from 1/2 to 3/4 HP. Refer to Change Notice 940168 for more info.

DUNCAN-PARNELL, INC., RALEIGH 27607 919-833-4877 331586

GAST MFG. CORP.		P.O. BOX 98763 Chicago, IL 60693		823-V2-G608X	
NAME OF VENDOR		VENDORS ADDRESS		VENDORS PART NO.	
 <b>TIPPER TIE</b> <small>A J BOYER INDUSTRIES COMPANY</small>		CHECKED BY <i>DM</i> DATE 6-20-94		<b>3/4 HP VACUUM PUMP</b> <b>SOURCE CONTROL DRAWING</b>	
		APPROVED BY <i>DM</i> DATE			
DRAWN BY <i>DM</i> DATE 6/15/94		RELEASED BY <i>DM</i> DATE		SIZE <b>A</b>	PART NO. <b>27-1016-05</b>
				SCALE -	DO NOT SCALE DRAWING
				SHEET	of 4

## REVISIONS

NO.	DESCRIPTION	DATE	APPROVED	NO.	DESCRIPTION	DATE	APPROVED
				05	PCN 950025	2/15	JM
				04	940350		JM
				03	SEE SHEET 1		

A SUBSTITUTE ITEM SHALL NOT BE USED WITHOUT PRIOR TESTING AND APPROVAL BY ENGINEERING

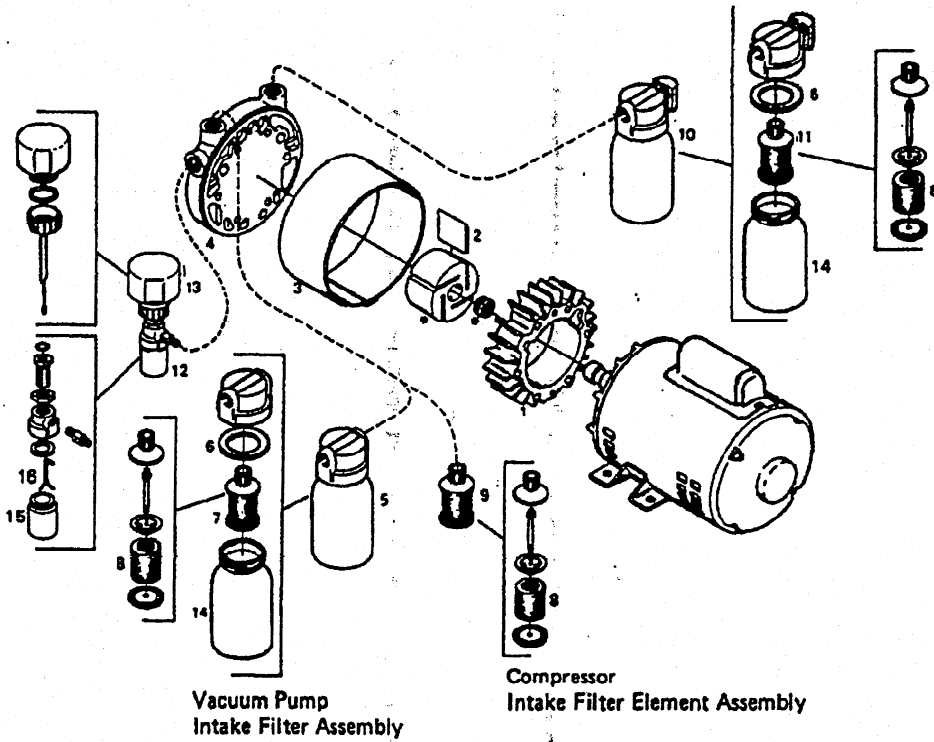

(SEE SHEET 3 FOR PART NUMBERS)

NAME OF VENDOR

VENDORS ADDRESS

VENDORS PART NO.



CHECKED BY DATE

*JM* 6-20-94

APPROVED BY DATE

*JM* 11

RELEASED BY DATE

*JM* 6

3/4 HP VACUUM PUMP  
SOURCE CONTROL DRAWING

SIZE

**A**

PART NO.

27-1016-05

DRAWN BY DATE

JOM 6-15-94

SCALE

—

DO NOT SCALE DRAWING

SHEET 2 of 4

## REVISIONS

NO.	DESCRIPTION	DATE	APPROVED	NO.	DESCRIPTION	DATE	APPROVED
				05	950025	2/15	DM
				04	940350		DM
				03	SEE SHEET 1		

A SUBSTITUTE ITEM SHALL NOT BE USED WITHOUT PRIOR TESTING AND APPROVAL BY ENGINEERING

Reference Number	Description	Part Quantity	0823-V2	TIPPER TIE PART NUMBER
1	Body	1	AK517	43-2000
+2	Vane	4	AK741	43-2001
3	Shroud	1	AK511	43-2002
4	End Plate	1	AK515B	43-2003
5	Intake Filter Assembly	1	AB599	43-1368
+6	Cover Gasket	2	AA405	43-1350
7	Filter Element Assembly	1	AC433	43-1358
+8	Cartridge	2	AC393	43-1344
10	Exhaust Muffler Assembly	1	AB599C	43-1369
11	Muffler Element Assembly	1	AC434	43-1359
12	Constant Level Oiler	1	AD126K	43-1316
13	Oil Reservoir	1	AD117	43-1314
14	Jar	2	AA805	43-1386
15	Jar	1	AA935A	43-1393
16	Wick	1	AA934	43-1392
	Service Kit	1	K486	

+ Denotes parts included in SERVICE KIT. Extra filter felts and cover gaskets are included in Kit when used for compressor.

\* (See schematic) Under most circumstances, rotor and tolerance ring should not be replaced in the field.

Rotor	1	AK512	43-2006
Tolerance Ring	1	AD126	43-1317

NAME OF VENDOR	VENDORS ADDRESS	VENDORS PART NO.
----------------	-----------------	------------------



CHECKED BY *DM* DATE 6-20-94

APPROVED BY *DM* DATE "

RELEASED BY *[Signature]* DATE "

3/4 HP VACUUM PUMP  
SOURCE CONTROL DRAWING

SIZE  
**A**

PART NO.

27-1016-05

DRAWN BY *JOM* DATE 6-15-94

SCALE —

DO NOT SCALE DRAWING

SHEET 3 of 4

## OPERATING AND MAINTENANCE INSTRUCTIONS

### GAST VACUUM PUMPS

**CONSTRUCTION:** Your rotary pump is a precision product, there being only .002 clearance at the top and .0025" - .0035" total at the ends of the rotor. The vanes take up their own wear and should last 5,000 - 15,000 hours operation depending upon application. Remember that it is designed for pumping clean-dry air, being built of cast iron and steel. Protect it against the entrance of dirt and excessive moisture, lubricate it, and you will receive years of trouble-free service.

**LUBRICATION:** Use of the correct oil and the proper amount of oil will insure years of operation. A film of oil provides the seal for the vanes to ride on and fill any tolerance clearance. Gast AD220 Oil is available in convenient quart containers from the factory or through Gast stocking representatives. Order by part #AD220. A high detergent 10 wt. automotive engine oil may be used as an equivalent to Gast AD220. In high ambient locations over 100 degrees Fahrenheit a 20 wt. oil should be used.

**Series 0323 and 0523-** For proper lubrication fill oil jar to level indicated on outside of jar. The oil wick (reference #7) should be doubled up, with the two ends submerged in oil at the bottom of the oil jar and the other end inserted in the connector, approximately 3/8" past the two breather holes (but not touching the oil feed hole). Both breather holes and the oil hole in the connector leading to pump, must be free of dirt and other restrictions. The rate of oil feed is determined by the diameter of the oil hole in the connector, ambient temperature, degree of vacuum or pressure at which the pump is operating, and the oil level of the jar.

**Series 0823 and 1023-** To fill the oil reservoir, pull reservoir (reference #13) up and out of adjusting sleeve of the constant level oiler (reference #12) and invert. Add oil through the tube hole. When filled, replace reservoir by inserting it through the adjusting sleeve so that the reservoir is firmly seated against the top of adjusting sleeve. The point of the tube should be approximately 1/4" from the bottom of the oil jar for normal lubrication. Adjustment of the tube can be accomplished by loosening the locknut and moving the threaded adjusting sleeve up or down until the desired position is reached. The adjusting sleeve is then locked in position with the locknut. The oil wick (reference #16) should be doubled up with the two ends submerged in oil at the bottom of the oil jar and the other end inserted in the connector, approximately 3/8" past the two breather holes (but not touching the oil feed hole). Both breather holes and the oil hole in the connector leading to the pump, must be free of dirt and other restrictions. The rate of oil feed is determined by the diameter of the connector hole, ambient temperature, degree of vacuum or pressure at which the pump is operating, and the oil level in the jar. For faster oil consumption, raise the reservoir tube away from the bottom of the oil jar. For slower oil consumption, lower the reservoir tube toward the bottom of the jar.

**STARTING:** If motor fails to start or slows down when under load, shut off and unplug. Check the supply voltage agrees with the motor post termination and the motor data nameplate. Also examine plug and switch. If unit is extremely cold, bring to room temperature before starting. If trouble appears to be in the motor, it might be cheaper to return the unit to pump manufacturer than to call an electrician, especially if within guarantee period. NOTE: ALL DUAL VOLTAGE MOTORS ARE SHIPPED FROM FACTORY SET FOR HIGH VOLTAGE.

**WARNING: THE MOTOR MAY BE THERMALLY PROTECTED AND WILL AUTOMATICALLY RESTART WHEN THE PROTECTOR RESETS. ALWAYS DISCONNECT POWER SOURCE BEFORE SERVICING. PERSONAL INJURY AND/OR PROPERTY DAMAGE WILL RESULT.**

**FLUSHING:** Most pump trouble can be corrected by flushing rather than by taking apart. A noisy or inefficient pump is frequently nothing more serious than a vane(s) stuck in rotor slot due to excessive oiling or foreign material in unit. Remove inlet and outlet accessories, add several teaspoons of solvent\* slowly at the intake while unit is running. Flush unit in a well ventilated area. Eye protection is recommended. Keep face away from exhaust port and do not flush unit with flammable solvent. Lay unit on side with outlet downward so solvent\* will work out again. Right the pump, add a few drops of oil at intake and attach accessories.

**DISASSEMBLY:** If foreign matter has entered pump, try flushing. If this does not eliminate the foreign matter, remove only the end plate and the four vanes (DO NOT at any time remove the rotor or loosen any of the electric motor thru-bolts.) Wash vanes, end plate, and pump chamber with solvent\*. Dry and re-lubricate lightly. If the pump fails to produce the proper vacuum or pressure, the top clearance between the rotor and body may have increased. A metallic clanging could mean the rotor and the body are touching. Remove end plate, loosen body bolts, and set top clearance at .002" (models 0323, 0523) or .004" (models 0823, 1023). This can be done by tapping "LIGHTLY" with miniature hammer on pump body (either top or bottom, depending upon whether clearance is too large or too small.) The rotor should be turned while setting clearance so that all points on the circumference of rotor will clear. End clearance, total for both sides of rotor, may vary from .0025" to .0035".

**INSPECTION:** Regular inspection and flushing may prevent extensive repairs. Dirty or clogged filter felts can be responsible for failure of the pump to build up pressure or produce vacuum and eventual overheating of the pump. Remove the felts and wash in solvent\*. If there is evidence of overheating or excessive noise, stop immediately for repairs. It is usually quickest and least expensive to send the unit in for repair. All returns are F. O. B. from your closest service center. The locations are listed on the cover page.

**WARNING: To prevent explosive hazard, DO NOT pump combustible liquids or vapors with these units. PERSONAL INJURY AND/OR PROPERTY DAMAGE WILL RESULT.**

\*Recommended Solvent: Gast Flushing Solvent part AH255. DO NOT USE KEROSENE, GASOLINE or any other flammable liquid. Personal injury and/or property damage will result.

# OPTIONS

CLIPPER MODEL C186L  
98-0150  
CLIPPER MODEL C486L  
98-0166  
CLIPPER MODEL Z2115  
98-0236

CLIPPER MODEL F186L  
98-0151  
CLIPPER MODEL F486L  
98-0167  
CLIPPER MODEL Z2105  
98-0235

00-8065, REF.  
VACUUM NOZZLE ASSY.  
00-8066, REF.  
VACUUM NOZZLE ASSY.  
00-0424, REF.  
SPLIT NOZZLE ASSY.

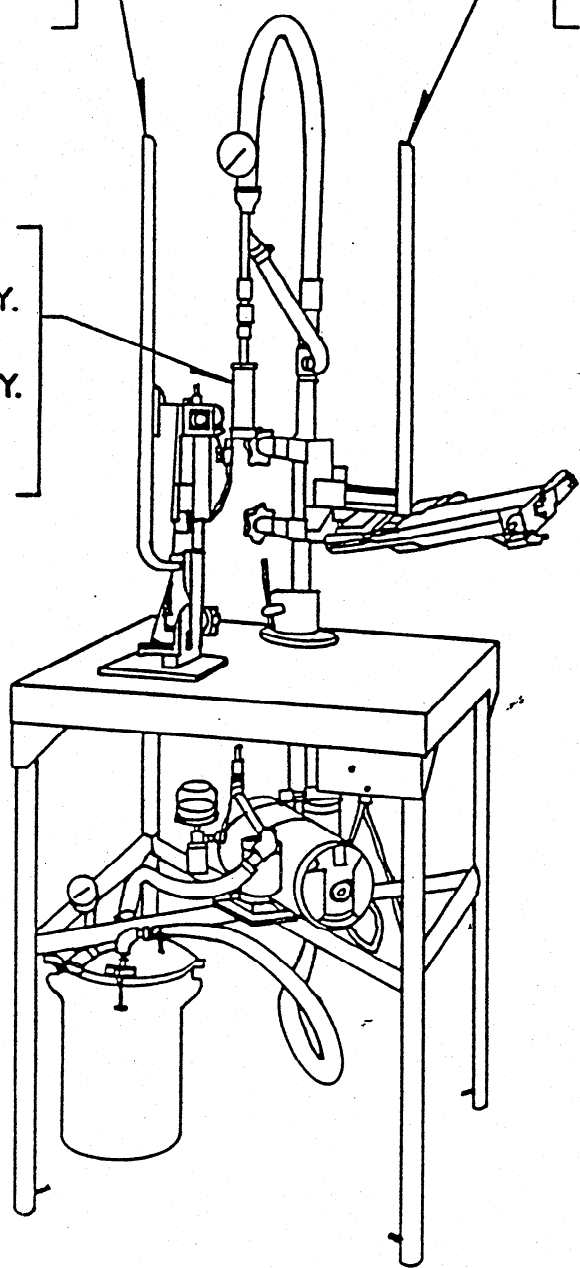

USED ON  
CV-E

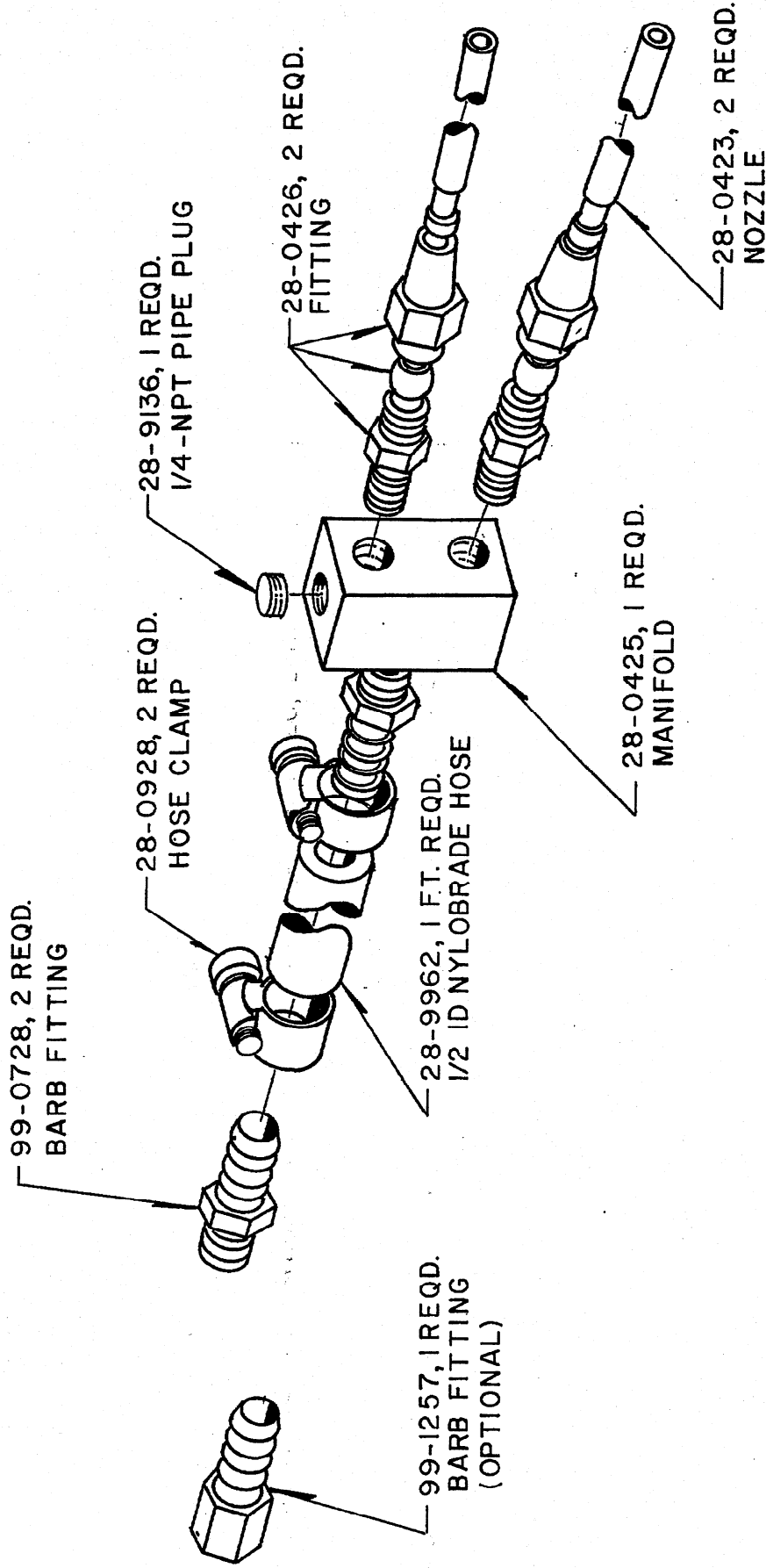

SPLIT NOZZLE ASSEMBLY  
00-0424 11-8-77

REV. 1

USED ON  
CV-E

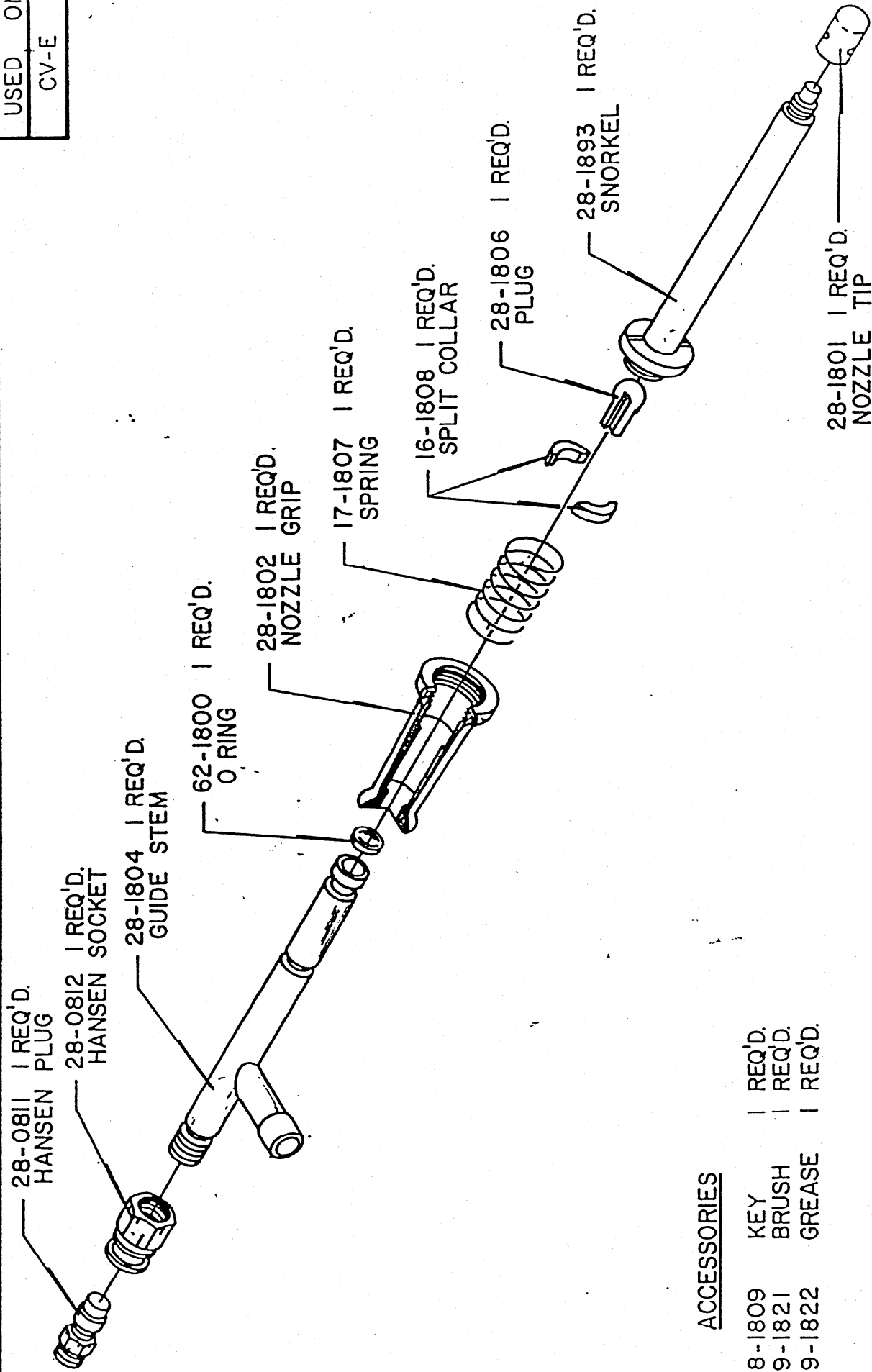

ACCESSORIES

- 28-1809 KEY 1 REQ'D.
- 99-1821 BRUSH 1 REQ'D.
- 99-1822 GREASE 1 REQ'D.

VACUUM NOZZLE ASSEMBLY  
00-8066 4-5-77

REV. 1

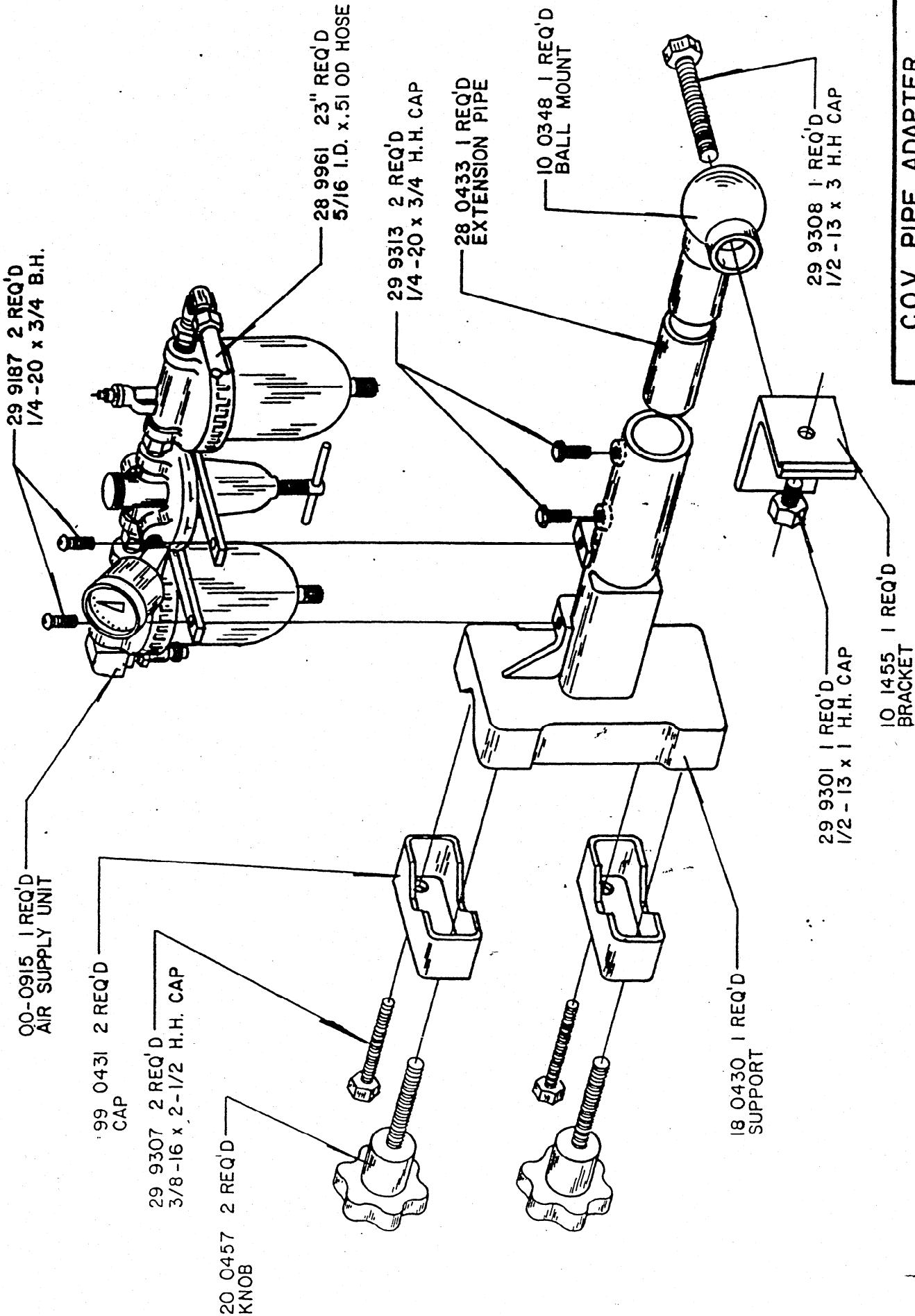

C.O.V. PIPE ADAPTER  
 00 0397 1-5-77

REV 1

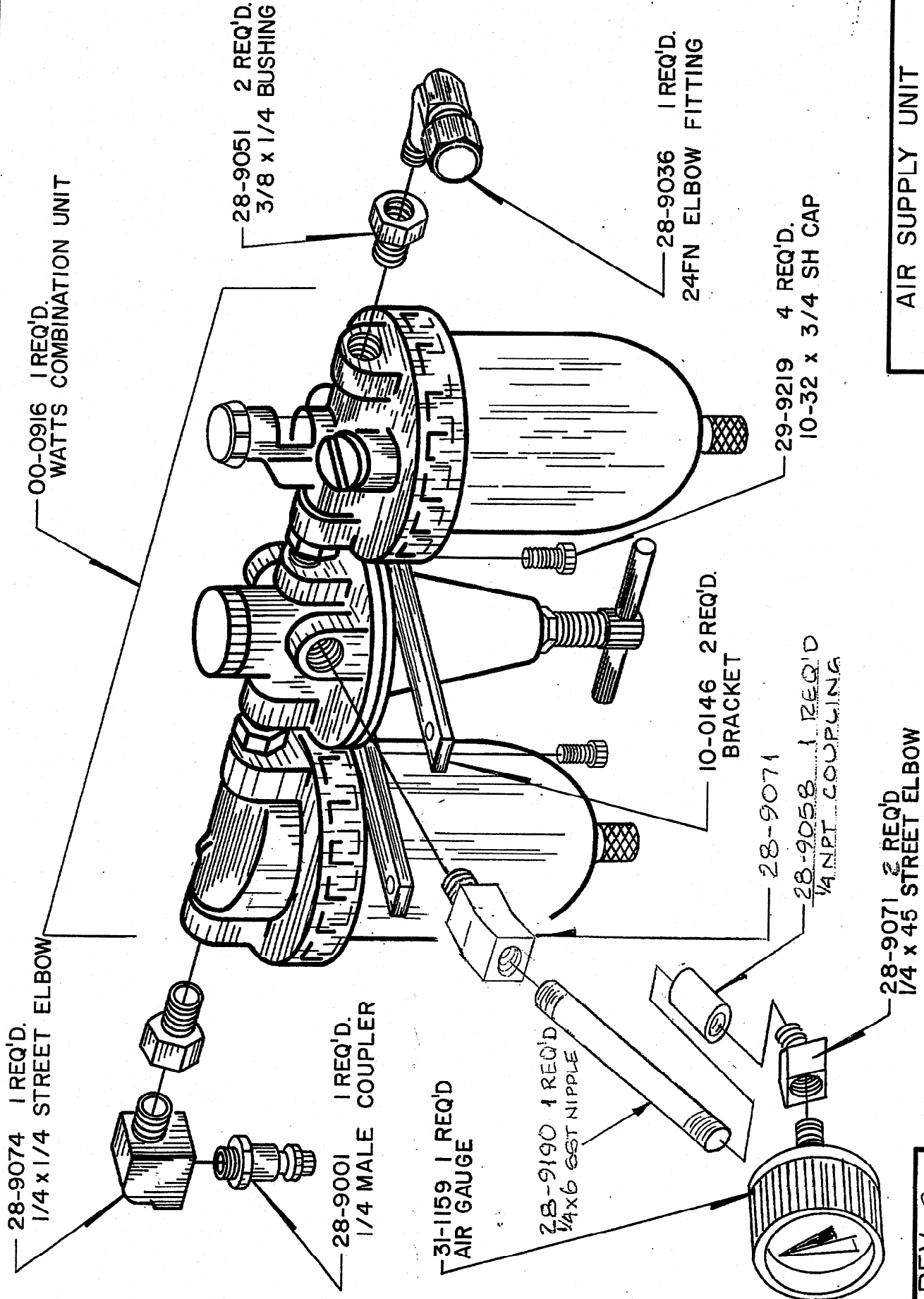

AIR SUPPLY UNIT  
00-0915 8-19-75

REV. 3

USED ON  
CV-E

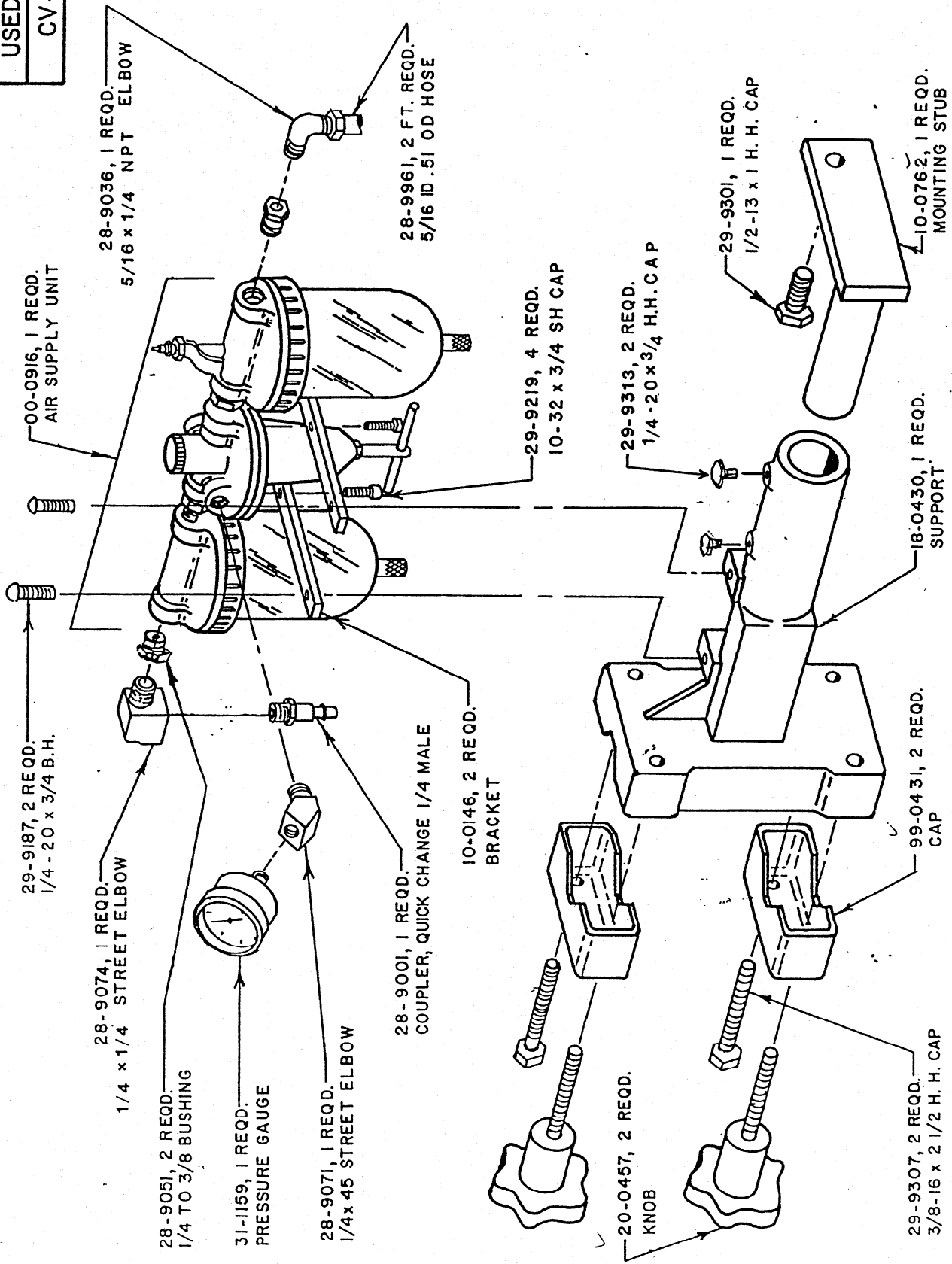

PIPE ADAPTER  
00-0783 11-8-77

REV. 2

USED ON  
CV-E WITH  
GASFLUSH

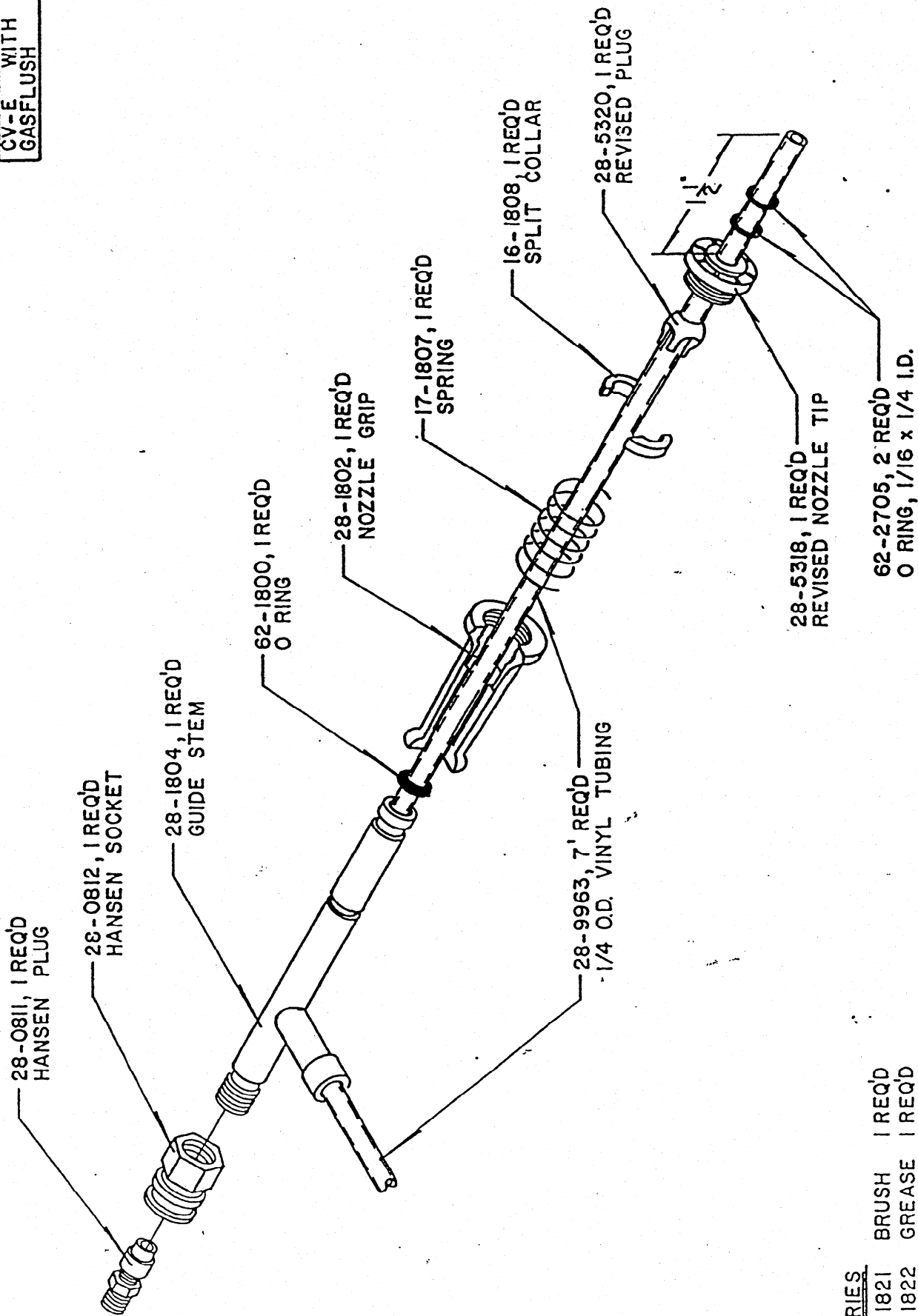

ACCESSORIES

- 1. 99-1821 BRUSH 1 REQ'D
- 2. 99-1822 GREASE 1 REQ'D

VACUUM NOZZLE ASSEMBLY  
00-5325 5-24-77

**ACCESSORIES:**

28-9963, 1/4 O.D. VINYL TUBING 8 FT REQ'D

USED ON  
CV-E WITH  
GASFLUSH

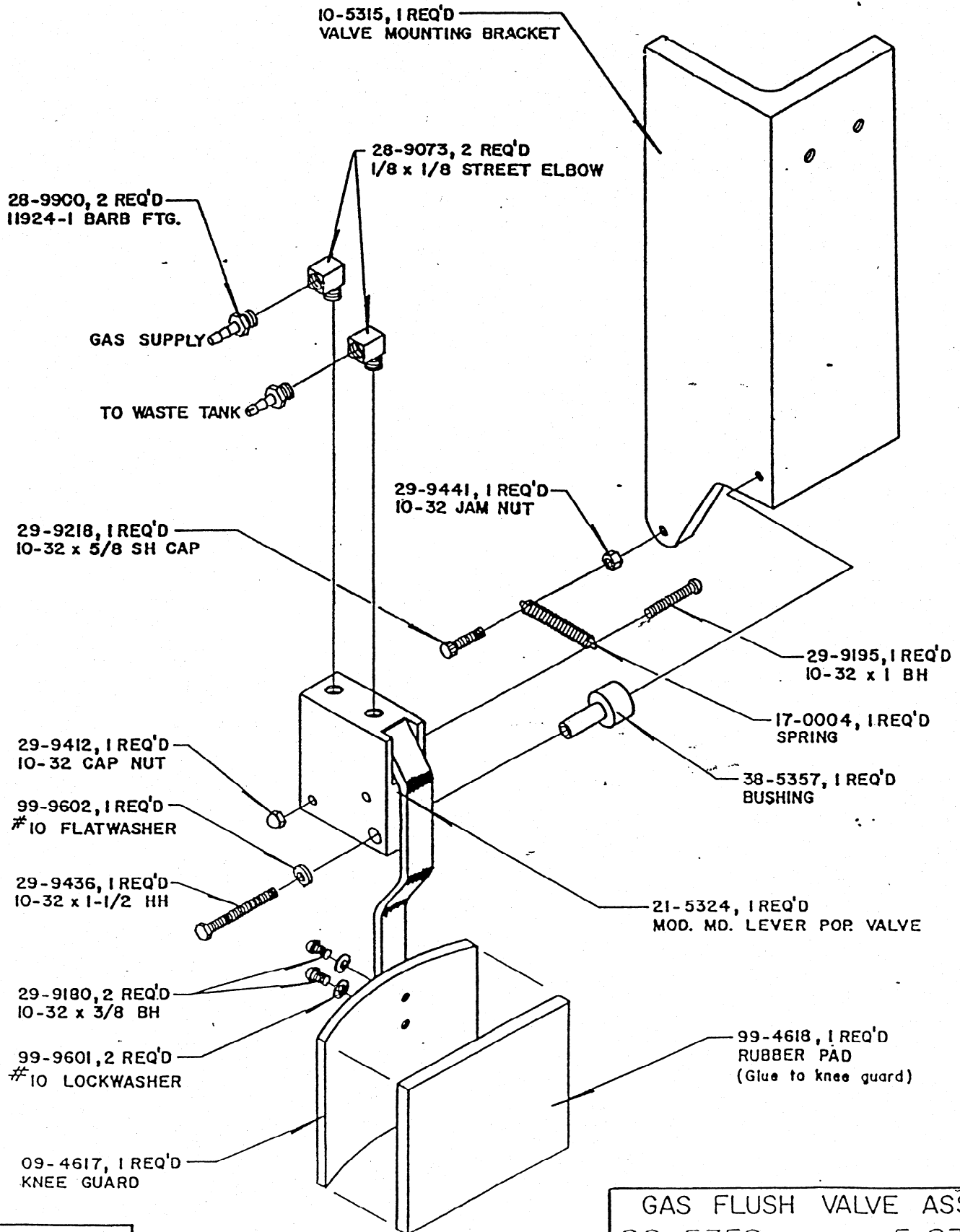

GAS FLUSH VALVE ASS'Y  
00-5359 5-23-77

USED ON

CV-E WITH  
GAS-FLUSH

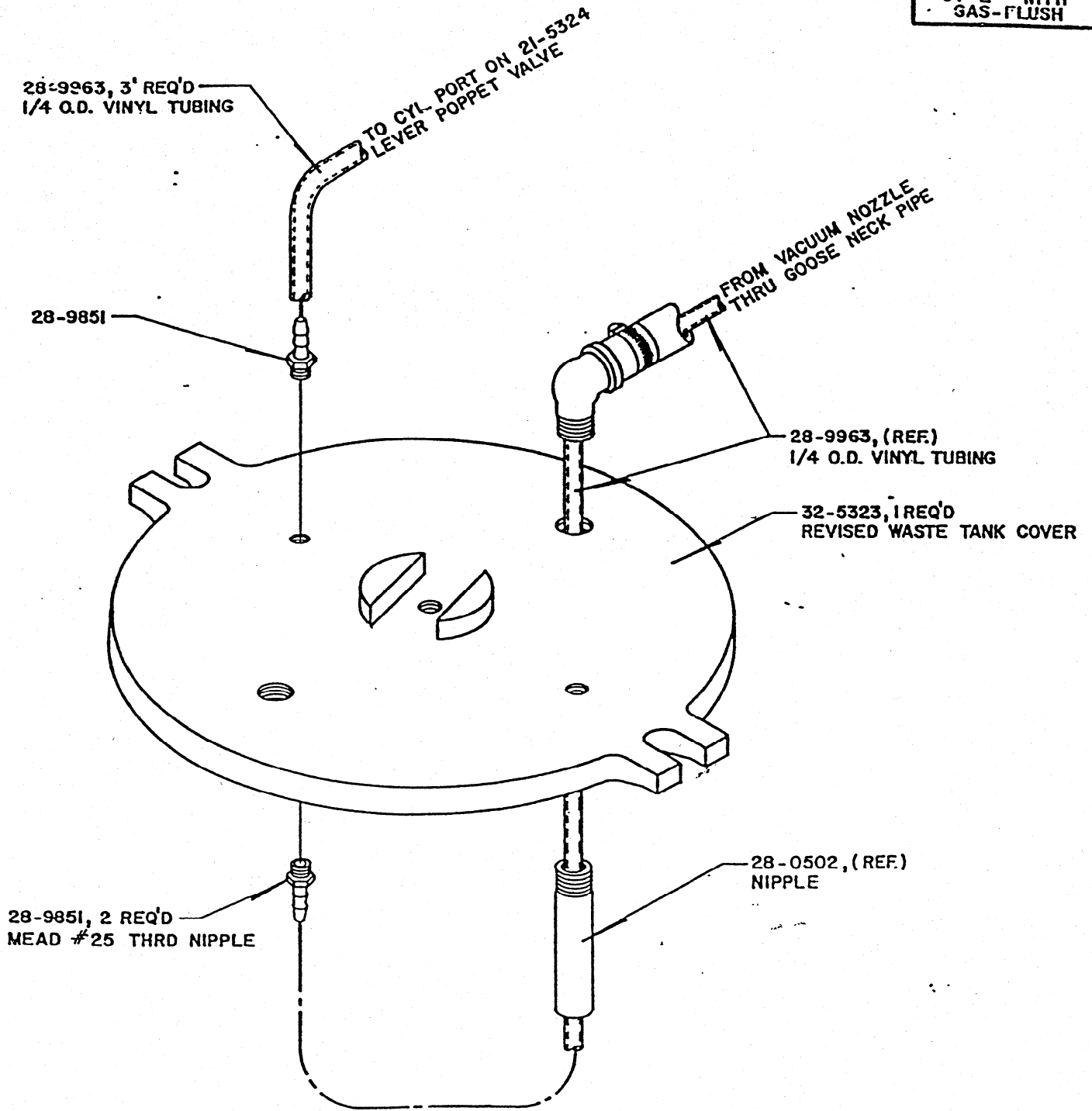

**NOTE:**

1. WHEN CONVERTING A CLIPPER VAC-E TO A CLIPPER VAC-E WITH GAS-FLUSH, REMOVE STANDARD WASTE TANK COVER, (32-0104) FROM THE WASTE TANK, (99-0401) AND REPLACE IT WITH THE REVISED WASTE TANK COVER, (32-5323), SHOWN ABOVE, USING THE SAME HARDWARE IN ADDITION TO TWO MEAD NIPPLES, (28-9851) AND NECESSARY TUBING, (28-9963).
2. REFER TO DWG. NO. 00-0803 FOR HARDWARE ITEMS.

WASTE TANK COVER ASS'Y

00-5363

5-27-77-

