

ASSEMBLED VIEW

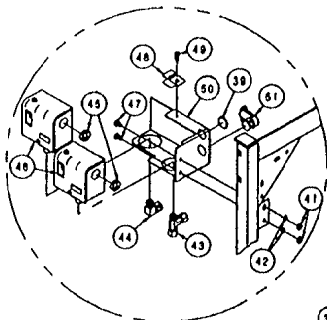

DETAIL A

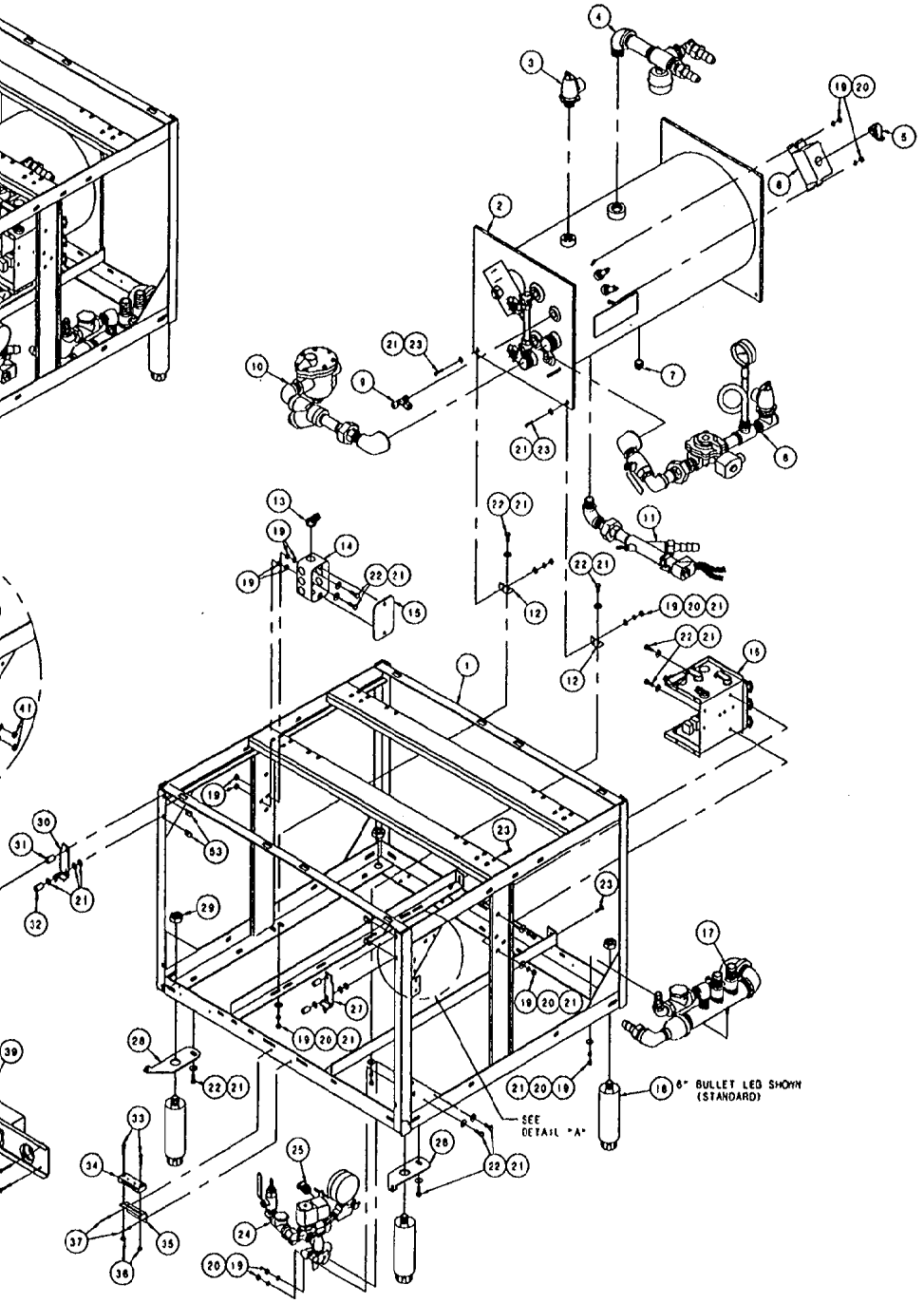

SEE DETAIL "A"

THIS DESIGN DESCRIBES A PROPRIETARY ITEM AND IS THE PROPERTY OF CLEVELAND RANGE. THIS DRAWING IS NOT TO BE COPIED OR USED WITHOUT THE APPROVAL OF CLEVELAND RANGE.

LET.	REVISIONS	DATE	BY
A	ADDED P/N 106090, 106099; P/N 23110 WAS	05-23-94	EAG
-	DTY(20), P/N 14618 WAS DIV(23), #C-2643		

64	4	106090	SCREW, TRUSS HD PHILPS, 10-24 X 1-1/2
63	4	106099	NUT, SLIP ON, 10-24, TINNERMAN
52	A/R	00994	SEALANT, RECTORSEAL
51	1	105247	CONNECTOR, 1/2 X 90° SHAPITE
50	1	526241	BRACKET, PRESSURE SWITCH, GAS/ELEC
49	1	10148	SCREW, HEX WASHER HEAD, SLTD
48	1	52490	BRACKET, PRESSURE SWITCH RETAINER
47	2	18218	SCREW, HEX HEAD, 1/4-20 X 3/5 S/S
46	2	18947	SWITCH, PRESSURE CONTROL
45	2	02599	BUSHING, INSULATING, 3/8 X 1/2 HEYCO
44	1	09198	FITTING, COMP, 3/8 X 1/4 MPT, 90°
43	1	100803	FITTING, COMP TEE 3/8 X 1/4 NPT X 3/8
42	2	23137	WASHER, LOCK INT TOOTH, 1/4 S/S
41	2	14688	NUT, HEX JAM, 1/4-20, S/S
40	1	105246	CONNECTOR, GREENFIELD 1/2 STRAIGHT
39	1	19329	PLUG, SNAP-IN, 1/2" FOR 7/8" HOLE
38	1	1048074	CONSOLE ASSY, 900 MM 2 SWITCH
37	A/R	18359	RIVET, 1/8 DIA, FLUSH BREAK S/S
36	4	14674	NUT, HEX 6-32 ZINC PLATED
35	1	53274	CLIP, MAGNET CATCH, S/S
34	2	03100	CATCH, MAGNETIC
33	4	19208	SCREW, HD, HEAD 6-32 X 1 ZINC PLTD
32	2	19552	SPACER
31	2	19555	SPACER
30	1	526811	HINGE, UPPER LEFT HINGE
29	4	14688	NUT, HEX JAM 3/4-10 ZINC PLTD
28	1	1020882	HINGE, LOWER LEFT HINGE
27	1	526821	HINGE, UPPER RIGHT HINGE
26	1	1020883	HINGE, LOWER RIGHT HINGE
25	1	105243	CONNECTOR, GREENFIELD 3/8 STRAIGHT
24	1	100304	WATER FEED ASSY, REV BEND GEN, 3/8"
23	4	19292	SCREW, ROUND HEAD, SLTD, 1/4-20 X 1" LG
22	10	19286	SCREW, HEX HEAD, 1/4-20 X 3/4
21	25	23110	WASHER, FLAT 1/4 X 5/8 X .085
20	11	23105	WASHER, LOCK 1/4 KATLINK STYLE
19	19	14618	NUT, HEX 1/4-20 S/S
18	4	08159	LEG, BULLET 6"
17	1	427601	DRAIN ASS'Y, MANIFOLD
16	1	44186	BOX, ELECTRIC, STEAM COIL W/COMPONENTS
15	1	02388	COVER, HANDI-BOX
14	1	02381	BOX, HANDI-BOX, ELECTRICAL
13	1	105244	CONNECTOR, GREENFIELD, 3/8" X 45°
12	2	101893	BRACKET, GENERATOR, MNTD LG STM COIL
11	1	101890	BLOWDOWN ASSM, AUTO, PCL STEAM COIL
10	1	101703	PIPING, STEAM OUTLET...PCL & STEAM COIL
9	1	030073	FITTING, COMP, TEE, 3/8" BRASS
8	1	101723	INLET, STEAM ASSM, PCL STEAM COIL
7	1	18802	PLUG, SO. HD, CORED, 1/2" PIPE, BLK
6	1	101112	BOX, PROBE COVER, LARGE STEAM COIL
5	1	105245	CONNECTOR, GREENFIELD, 3/8" X 90°
4	1	101724	PIPING ASSM, STEAM OUTLET, PCL
3	1	22131	VALVE, SAFETY, 3/4" 16 PSI, BRONZE
2	1	101927MP	GENERATOR ASSM, LG STM COIL, W/REF PARTS
1	-	1018921	BASE, WELDMENT, 900MM, A C S
1	-	101892	BASE WELDMENT, 900MM, S/S

ITEM	QTY	PART NO.	DESCRIPTION
TOLERANCES (EXCEPT AS NOTED)			
CLEVELAND RANGE INC. 1333 East 178th St., Cleveland, Ohio 44110-2074			
DECIMAL & N/A	SCALE 1/8"=1	DRAWN BY E. GRIVEAS	APPROVED BY
ANGULAR & N/A	TITLE	BASE ASSEMBLY, LARGE STEAM COIL GENERATOR 900 MM, PCL	
CK	DATE 12-06-93	DRAWING NO. C - FJE0001	REV. A

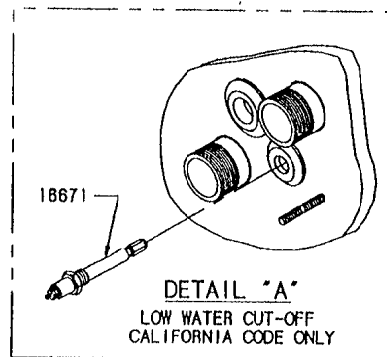
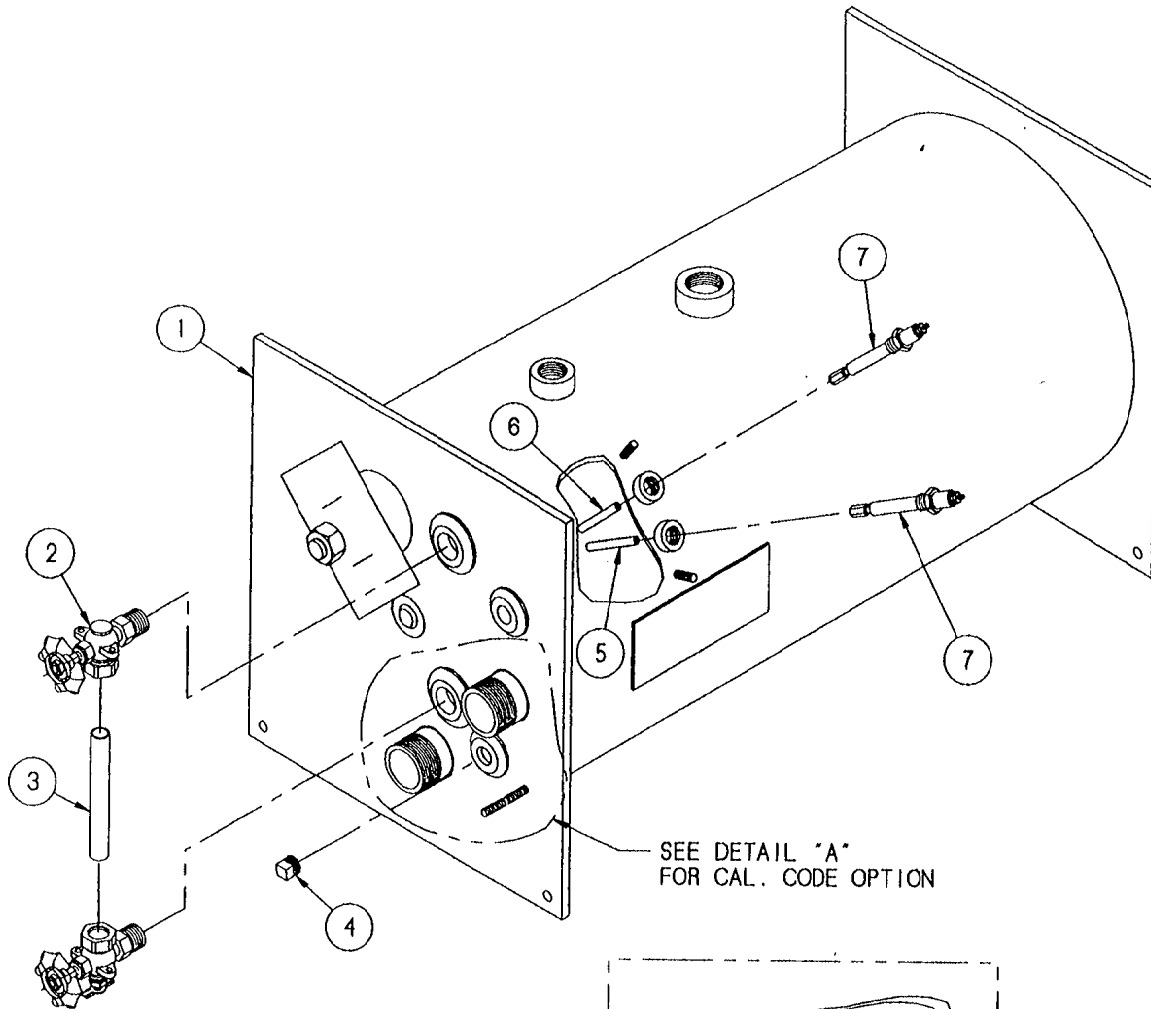

THIS DESIGN DESCRIBES A PROPRIETARY ITEM AND IS THE PROPERTY OF CLEVELAND RANGE. THIS DRAWING IS TO BE COPIED OR USED WITHOUT THE APPROVAL OF CLEVELAND RANGE.

8	A/R	00934	SEALANT, RECTORSEAL
7	2	16671	PROBE, WARRICK, 4-5/16" LG.
6	1	101913	EXTENSION, PROBE, HIGH WATER, PCL
5	1	101912	EXTENSION, PROBE, LOW WATER, PCL
4	1	18601	PLUG, SQUARE HEAD, 3/8" PIPE BLACK
3	1	101900	GAUGE, WATER, 5/8" X 4.625", GLASS
2	1	07176	GAUGE FITTINGS, WATER, 1/2"
1	1	101927	GENERATOR ASM, 2 PROBE, LG ST COIL
ITEM	QTY.	PART NO.	DESCRIPTION

TOLERANCES (UNLESS AS NOTED)			
CLEVELAND RANGE INC. 1333 East 179th St. Cleveland, Ohio 44110-2574			
DECIMAL ± N/A	SCALE 3/8=1	DRAWN BY E. GRIVEAS	APPROVED BY
ANGULAR ± N/A	TITLE GENERATOR ASSEMBLY, LARGE STEAM COIL W/ REFERENCE PARTS		
CK	DATE 11-23-93	DRAWING NO. C - 101	REV. WP

LET.	REVISIONS	DATE	BY
A	REPLACED 19927 WITH 19921 AND 14859 WITH 14858. SEE EC-C-2618	4/25/84	DLD
B	ADDED P/N 106698, 106699; P/N 23116 WAS QTY(23). P/N 14818 WAS QTY(17), #C-2643	05-23-94	EAG

Not used after
4-2004 convection
6-2004 pressure

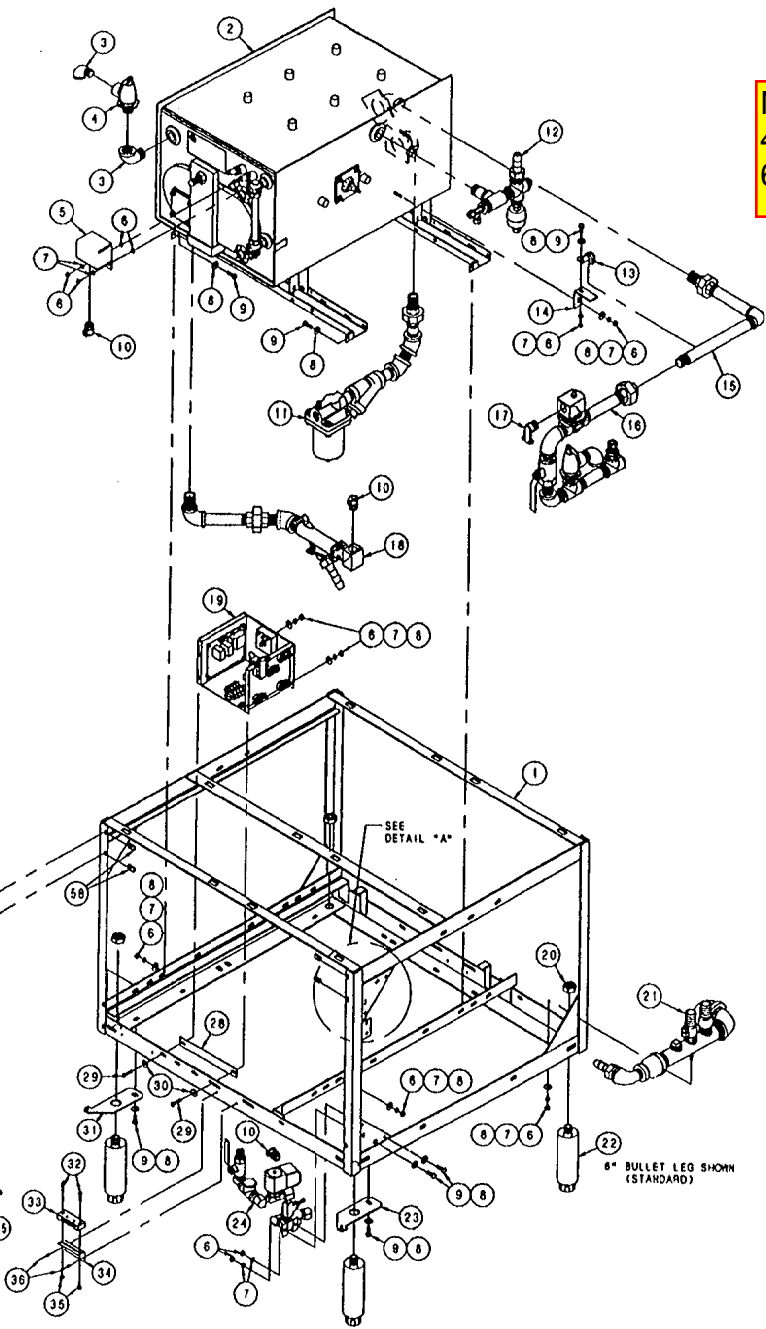
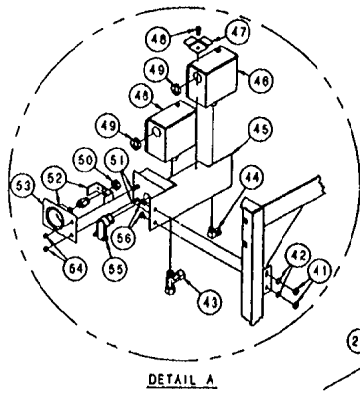
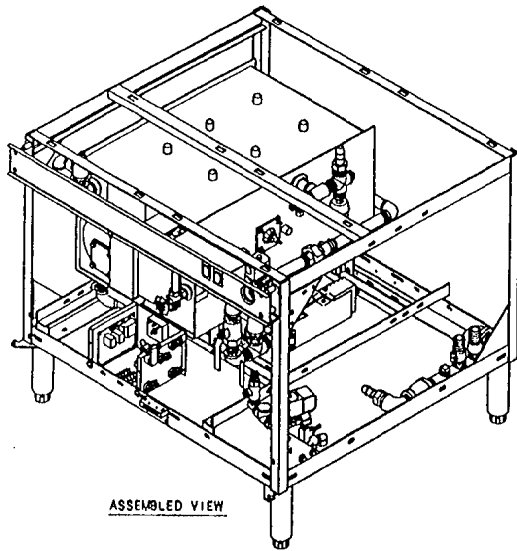

ITEM	QTY	PART NO.	DESCRIPTION
39	4	106898	SCREW, TRUSS HD PHILPS, 10-24 X 1-1/2
38	4	108889	NUT, SLIP ON, 10-24, TINNED
37	N/A	00934	SEALANT, RECTORSAL
36	2	19218	SCREW, HEX HEAD, 1/4-20 X 3/5 S/S
35	1	108247	CONNECTOR, GREENFIELD, 3/8" X 90°
34	2	14868	NUT, ELASTIC LOCK, 1/4-20, S/S
33	1	52548	BRACKET, PRESSURE GAUGE, 2 X 4-1/4
32	1	07188	GAUGE, PRESSURE, PANEL MOUNT
31	2	19921	SILCO, WELD, 1/4-20 X 1/2, S/S
30	1	08197	FITTING, COMPRESSION, 3/8" T X 1/4" FPT
29	2	02698	BUSHING, INSULATING, 3/8 X 1/2 HEYCO
28	1	19148	SCREW, HEX WASHER HEAD, 3/8 X 1/2 HEYCO
27	1	52499	BRACKET, PRESSURE SWITCH RETAINER
26	2	19947	SWITCH, PRESSURE CONTROL
25	1	52840	BRACKET, PRESSURE SWITCH 2 PROBE
24	1	08198	FITTING, COMP, 3/8 X 1/4 NPT, 90°
23	1	100803	FITTING, COMP TEE 3/8 X 1/4 NPT X 3/4
22	2	23137	WASHER, LOCK INT. TOOTH, 1/4 S/S
21	2	14868	NUT, HEX JAW, 1/4-20, S/S
20	1	19329	PLUG, SHAP-IN, 1/2" FOR 7/8" HOLE
19	1	105248	CONNECTOR, GREENFIELD 1/2 STRAIGHT
18	1	1048074	CONSOLE ASSY, 90D MM 2 SWITCH
17	1	412182	BRACKET, ASS'Y, TOP HINGE, L.S.
16	A/R	16358	RIVET, 1/8 DIA, FLUSH BREAK S/S
15	4	14874	NUT, HEX 8-32 ZINC PLATED
14	1	33274	CLIP, MAGNET CATCH, S/S
13	2	03100	CATCH, MAGNETIC
12	4	19208	SCREW, RD HEAD 8-32 X 1 ZINC PLTD
11	1	1020832	HINGE, LOWER LEFT HINGE
10	2	101855	WASHER, FLAT, #10 S/S
9	2	19287	SCREW, PAN HEAD, #10-24 X 5 LG S/S
8	1	86732	PLATE, COVER, STEAM COIL BASE
7	2	19555	SPACER
6	2	05567	SPACER
5	1	412192	BRACKET, ASS'Y, TOP HINGE, R.S.
4	1	440702	WATER FEED ASSY, REV BEND GEN
3	1	1020863	HINGE, LOWER RIGHT HINGE
2	4	06156	LEG, BULLET 8"
1	1	42781	DRAIN ASSEMBLY, MANIFOLD, STEAM COIL
0	1	14868	NUT, HEX JAW 3/4-10 ZINC PLTD
19	1	44188	BOX, ELECTRIC, STEAM COIL W/COMPONENTS
18	1	42813	PIPING, GENERATOR DRAIN, ST.CO. MANUAL
17	1	108248	CONNECTOR, GREENFIELD, 3/8" X 90°
16	1	42809	PIPING, STEAM SUPPLY, STEAM COIL
15	1	52808	PIPING, STEAM SUPPLY, ASSM, STEAM COIL
14	1	52830	BRACKET, PIPE, REV BEND GEN.
13	1	03197	CLAMP, 1 HOLE, RIGID, 3/4"
12	1	428123	PIPING, STEAM OUTLET, REV BEND
11	1	42810	PIPING, CONDENSATE DRAIN, STEAM COIL
10	3	105243	CONNECTOR, GREENFIELD, 3/8 STRAIGHT
9	7	19288	SCREW, HEX HEAD, 1/4-20 X 3/4
8	19	23118	WASHER, FLAT 1/4 X 5/8 X 083
7	11	23105	WASHER, LOCK 1/4 KATLINK STYLE
6	19	14818	NUT, HEX 1/4-20 S/S
5	1	52305	BOX, PROBE COVER, 2 PROBES, A.C.S.
4	1	22131	VALVE, SAFETY, 3/4" 90° BRONZE
3	2	05259	ELBOW, STREET, 3/4", 90° BLACK
2	1	40821MP	GENERATOR ASM, STEAM COIL W/REF PARTS
1	-	411201	BASE WELDMENT, 900MM, A.C.S.
1	-	41120	BASE WELDMENT, 900MM, S/S

THIS DESIGN DESCRIBES A PROPRIETARY ITEM AND IS THE PROPERTY OF CLEVELAND RANGE. THIS DRAWING IS NOT TO BE COPIED OR USED WITHOUT THE APPROVAL OF CLEVELAND RANGE.

NEXT ASS'Y DHE0018

ITEM	QTY	PART NO.	DESCRIPTION
TOLERANCES UNLESS SHOWN			
1393 East 179th St. Cleveland, Ohio 44110-2574			
DECIMAL	SCALE	DRAWN BY	APPROVED BY
± N/A	1/8" = 1"	E. GRIVEAS	N.T.
ANGULAR	TITLE	BASE ASSEMBLY, STEAM COIL	
± N/A		900 MM	
DATE	DRAWING NO.	REV	
CK 10-22-93	C - DHE0012	B	

LET.	REVISIONS	DATE	BY
A	REPLACED 19927 WITH 19921 AND 14619 WITH 14669. SEE ED C-1010.	4/25/04	DLB
B	ADDED P/N 106698, 106699; P/N 23118 WAS QTY(33), P/N 14618 WAS QTY(21), P/N 1061935 WAS 1048075. PER E.O. #C-2643	05-23-94	EAG

Not used after
4-2004 convection
6-2004 pressure

81	4	108898	SCREW, TRUSS HD. PHLPS. 10-24 X 1-1/2
80	4	108899	NUT, SLIP ON. 10-24. TINNERMAN
59	A/R	00931	SEALANT, RECTORSEAL
58	2	19216	SCREW, HEX HEAD. 1/4-20 X 3/5 S/S
57	1	105247	CONNECTOR, GREENFIELD. 1/2 X 90° SHAP-LITE
56	2	14888	NUT, ELASTIC LOCK. 1/4-20. S/S
55	1	52548	BRACKET, PRESSURE GAUGE. 2 X 1-1/4
54	1	07168	GAUGE, PRESSURE. PANEL MOUNT
53	2	19921	STUD, WELD. 1/4-20 X 1/2. S/S
52	1	08197	FITTING, COMPRESSION. 3/8" X 1/4" FPT
51	2	02598	BUSHING, INSULATING. 3/8 X 1/2 HEYCO
50	1	19148	SCREW, HEX WASHER HEAD, STD
49	1	52498	BRACKET, PRESSURE SWITCH RETAINER
48	2	19947	SWITCH, PRESSURE CONTROL
47	1	82840	BRACKET, PRESSURE SWITCH 2 PROBE
46	1	08188	FITTING, COMP. 3/8 X 1/4 MPT. 90°
45	1	100883	FITTING, COMP TEE 3/8 X 1/4 MPT X 3/8
44	2	23137	WASHER, LOCK INT. TOOTH. 1/4 S/S
43	2	14888	NUT, HEX JAM. 1/4-20. S/S
42	1	19329	PLUG, SNAP-IN. 1/2" FOR 7/8" HOLE
41	1	105248	CONNECTOR, GREENFIELD 1/2 STRAIGHT
40	1	1061935	CONSOLE ASSY. 1050 MM 2 SWITCH
39	1	412187	BRACKET, ASS'Y., TOP HINGE, L. S.
38	A/R	18959	RIVET, 1/8 DIA. FLUSH BREAK S/S
37	4	14874	NUT, HEX 6-32 ZINC PLATED
36	1	53274	CLIP, MAGNETIC CATCH. S/S
35	2	03100	CATCH, MAGNETIC
34	4	19208	SCREW, RD. HEAD 8-32 X 1 ZINC PLTD
33	1	102082	HINGE, LOWER LEFT HINGE
32	2	101885	WASHER, FLAT. #10 S/S
31	2	19287	SCREW, PAN HEAD. #10-24 X 5 LG S/S
30	1	96732	PLATE, COVER, STEAM COIL BASE
29	2	19855	SPACER
28	2	193582	SPACER
27	1	412182	BRACKET, ASS'Y., TOP HINGE, R.S.
26	1	440702	WATER FEED ASSY., REV BEND GEN
25	1	102083	HINGE, LOWER RIGHT HINGE
24	4	08158	LEG, BULLET 4"
23	1	104873	DRAIN ASSEMBLY, MANIFOLD, STEAM COIL
22	4	14888	NUT, HEX JAM 3/4-10 ZINC PLTD
21	1	44188	BOX, ELECTRIC, STEAM COIL W/COMPONENTS
20	1	101873	BRACE, KETTLE SUPPORT
19	1	53111	CHANNEL, KETTLE SUPPORT
18	1	42813	PIPING, GENERATOR DRAIN, ST. CO. MANUAL
17	1	105245	CONNECTOR, GREENFIELD. 3/8" X 90°
16	1	42809	PIPING, STEAM SUPPLY, STEAM COIL
15	1	42809	PIPING, STEAM SUPPLY, ASSM. STEAM COIL
14	1	52530	BRACKET, PIPE, REV BEND GEN.
13	1	03197	CLAMP, 1 HOLE, RIGID. 3/4"
12	1	428123	PIPING, STEAM OUTLET, REV BEND
11	1	42810	PIPING, CONDENSATE DRAIN, STEAM COIL
10	3	105243	CONNECTOR, GREENFIELD 3/8 STRAIGHT
9	13	19288	SCREW, HEX HEAD. 1/4-20 X 3/4
8	29	23118	WASHER, FLAT 1/4 X 5/8 X .085
7	18	23105	WASHER, LOCK 1/4 KATLINK STYLE
6	17	14818	NUT, HEX 1/4-20 S/S
5	1	52305	BOX, PROBE COVER, 2 PROBES, A.C.S.
4	1	32131	VALVE, SAFETY. 3/4" 16 PSI. BRONZE
3	2	05259	ELBOW, STREET. 3/4", 90° BLACK
2	1	40921MP	GENERATOR ASM. STEAM COIL W/REF PARTS
1	-	411271	BASE, WELDMENT. 1050MM. A.C.S
1	-	41127	BASE WELDMENT. 1050MM. S/S

ITEM	QTY	PART NO.	DESCRIPTION
TOLERANCES UNLESS SHOWN:			
CLEVELAND RANGE INC.			
1939 East 179th St. Cleveland, Ohio 44110-2574			
DECIMAL & N/A	SCALE 1/8"=1"	DRAWN BY E. GRIVEAS	APPROVED BY M.T
ANGULAR & N/A	TITLE BASE ASSEMBLY, STP 1050 MM		
CK	DATE 10-27-93	DRAWING NO. C - LMF0013	REV. 8

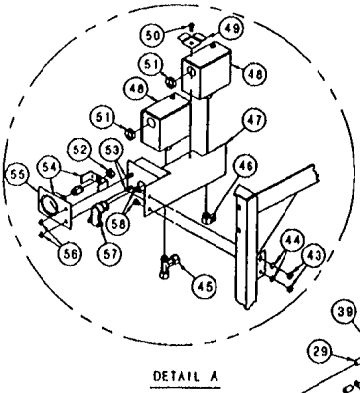
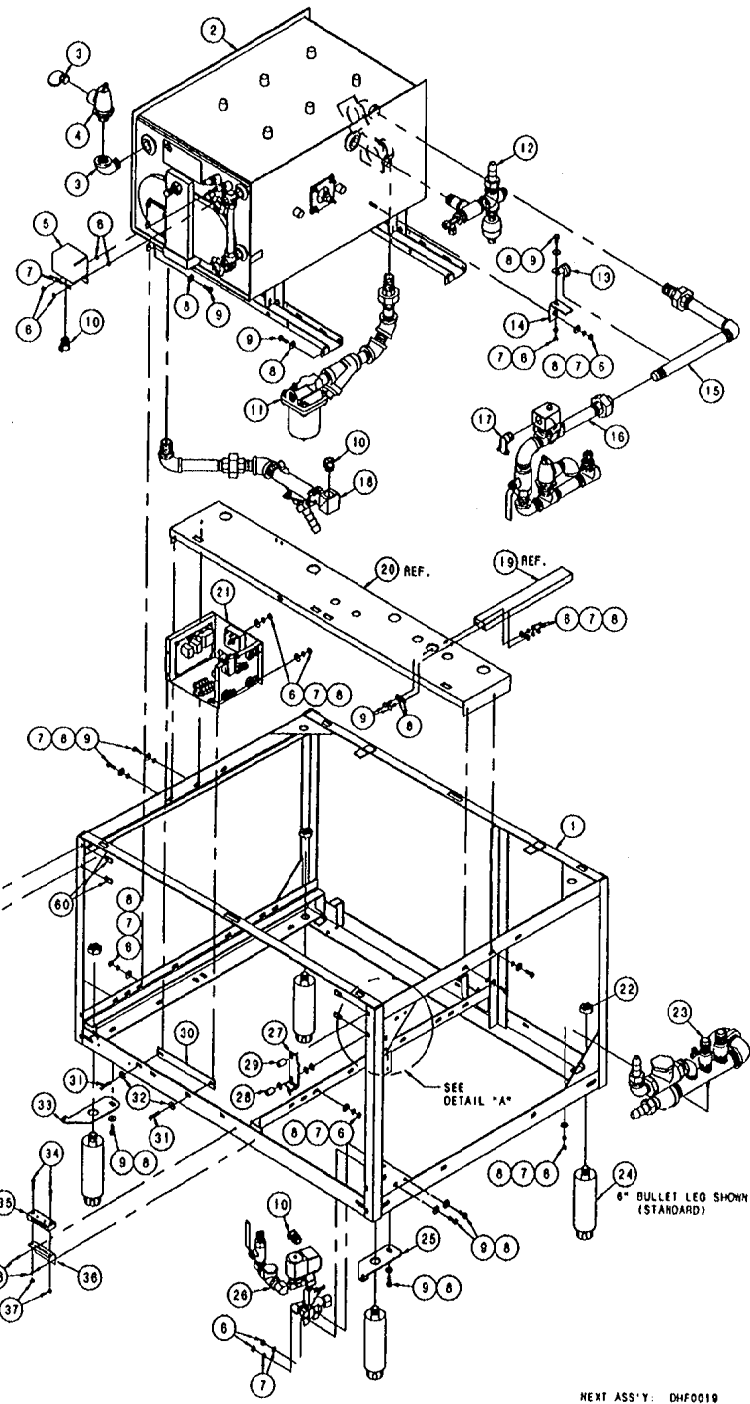
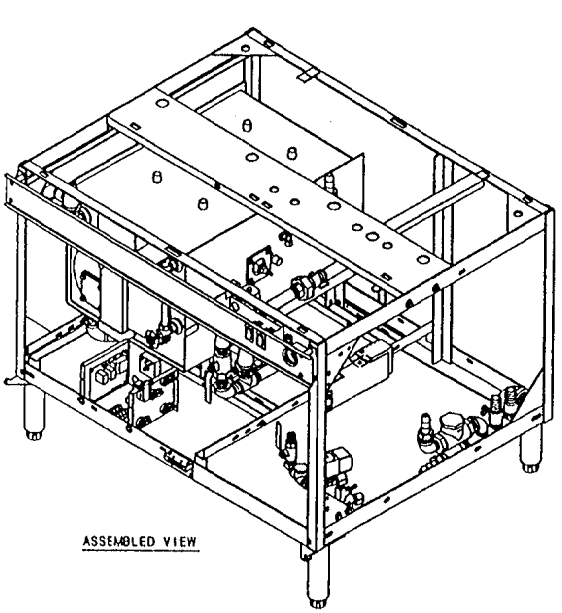

THIS DESIGN IS A PROPRIETARY ITEM AND IS THE PROPRIETARY PROPERTY OF CLEVELAND RANGE. THIS DRAWING IS TO BE COPIED OR USED WITHOUT THE APPROVAL OF CLEVELAND RANGE.

NEXT ASS'Y.: DHF0019

NOTES:

- CHANNEL SUPPORT SHOWN (P/N 89986) IS USED ON 800MM BASE. CHANNEL SUPPORT NOT SHOWN (P/N 89987) IS USED ON 900 & 1050 MM BASES.

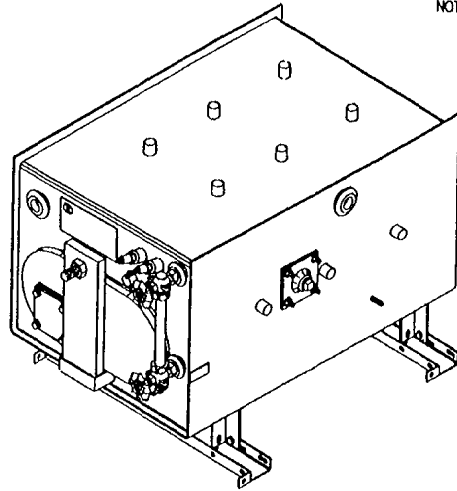

ASSEMBLED VIEW

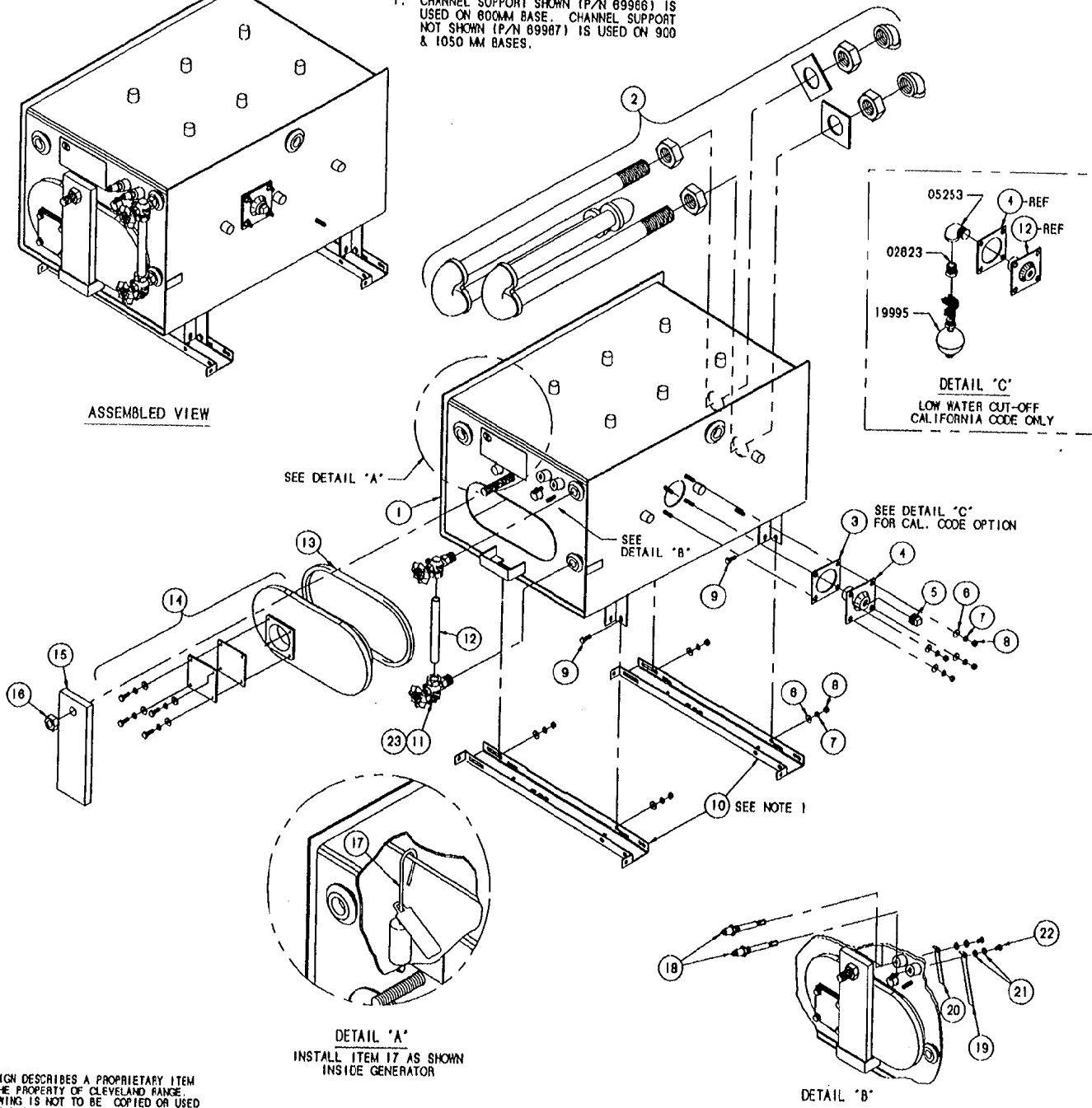

Not used after
4-2004 convection
6-2004 pressure

NO.	QTY.	PART NO.	DESCRIPTION
23	A/R	00934	SEALANT, RECTORSEAL
22	2	19218	SCREW, HEX HEAD, 1/4-20 X 3/8 S/S
21	4	23151	WASHER, INTERNAL TOOTH LOCK, 1/4
20	1	82452	EXTENSION, WATER PROBE 1/2 X 3-1/8
19	1	82453	EXTENSION, WATER PROBE, 1/2 X 4-5/8
18	2	18871	PROBE WARRICK, 4-5/16" LG
17	1	43895	ANODE ASSM CORROSION PREVENTATIVE
16	1	100284	NUT, HEAVY HEX 5/8-11 UNC SA-194
15	1	52517	BAR, HAND HOLE, 5/8" X 3" X 9-1/8"
14	1	40425	PLATE ASSEMBLY, HAND HOLE
13	1	07116	GASKET, HAND HOLE
12	1	07302	GAUGE, WATER, 5/8 X 6, GLASS
11	1	07170	GAUGE, FITTINGS, WATER, 1/2"
10	-	89986	SUPPORT, GEN. MTG. CHANNEL 800MM S/S
	-	89987	SUPPORT, GEN MTG CHANNEL 900/1050MM
9	4	19288	SCREW, HEX HEAD, 1/4-20 X 3/4
8	8	14618	NUT, HEX, 1/4 - 20 S/S
7	8	23105	WASHER, SPLIT LOCK, 1/4 S/S
6	8	23118	WASHER, FLAT, 1/4 S/S
5	1	16802	PLUG, SQUARE 1/2 PIPE, BLACK
4	1	41943	PLATE, MOUNTING
3	1	07128	GASKET, HEATER
2	1	40401	EXCHANGER, HEAT ASSY, STEAM COIL
1	1	408211	GENERATOR WELDMENT, STEAM COIL

TOLERANCES (EXCEPT AS NOTED)		CLEVELAND RANGE INC.	
1333 East 179th St. Cleveland, Ohio 44110-2574		DRAWN BY GRIVEAS	
DECIMAL ± N/A	SCALE 3/16	APPROVED BY	M.T.
ANGULAR ± N/A	TITLE STEAM COIL GENERATOR ASSEMBLY W/ REFERENCE PARTS		
CK	DATE 10-18-93	DRAWING NO. C-408211WP	REV. -

THIS DESIGN DESCRIBES A PROPRIETARY ITEM AND IS THE PROPERTY OF CLEVELAND RANGE. THIS DRAWING IS NOT TO BE COPIED OR USED WITHOUT THE APPROVAL OF CLEVELAND RANGE.

LET.	REVISIONS	DATE	BY
D	REDRAWN	9-10-80	SPS
E	ITEM #5 WAS 8-02147 REVISED PER E.O. #1022	3-05-85	DJP
F	REDRAWN AND ADDED ITEMS 1 TO 3 PER E.O. 1C-1994	08-12-91	PJD

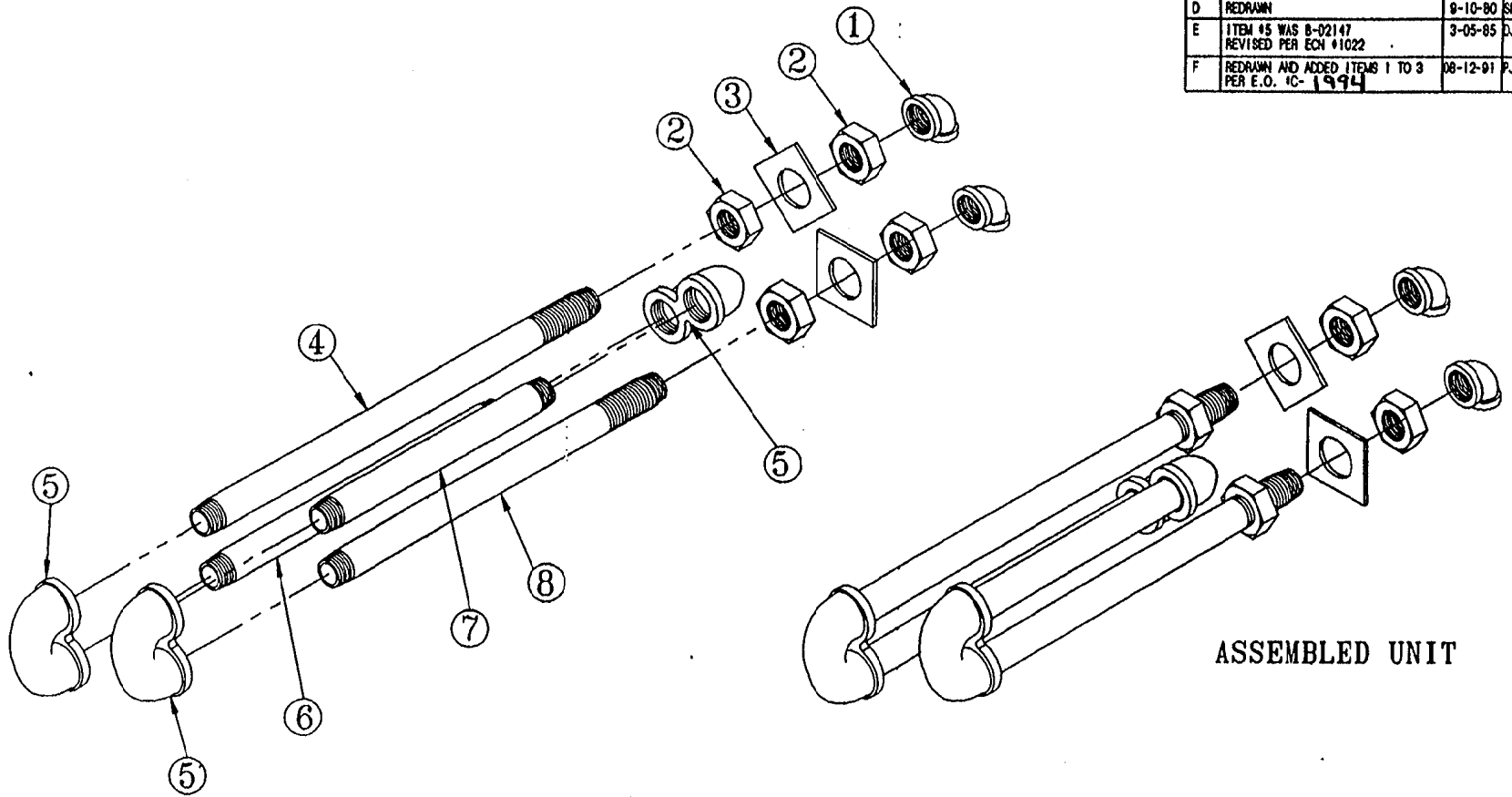

ASSEMBLED UNIT

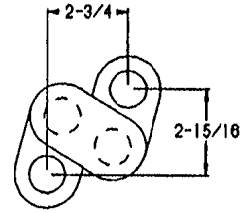
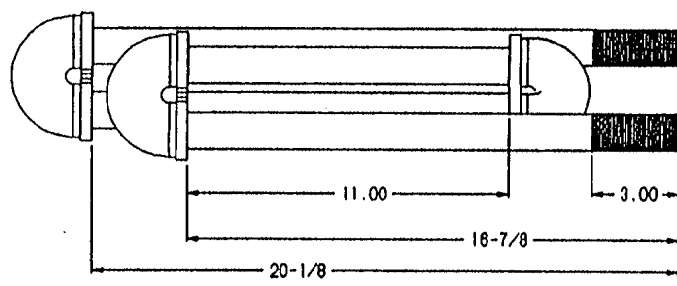

ITEM	QTY.	PART NO.	DESCRIPTION
8	1	18475	PIPE, 1-1/4 X 17.375", BRASS
7	1	18478	PIPE, 1-1/4 X 12.00", BRASS
6	1	18474	PIPE, 1-1/4 X 15.250", BRASS
5	3	02150	FITTING, RETURN BEND 1-1/4 NPT. UED. PTH. 180°
4	1	18473	PIPE, 1-1/4 X 20.825", BRASS
3	2	23135	WASHER, FLAT, 0 GA., 3" X 3" 8/16
2	4	14812	NUT, LOCK; LGT. PTH., 1-1/4 PIPE, BRASS
1	2	05270	ELBOW, 90° 1-1/4 X 3/4, BLACK

THIS DESIGN DESCRIBES A PROPRIETARY ITEM AND IS THE PROPERTY OF CLEVELAND RANGE. THIS DRAWING IS NOT TO BE COPIED OR USED WITHOUT THE APPROVAL OF CLEVELAND RANGE.

TOLERANCES EXCEPT AS SHOWN			
DECIMAL	± N/A	SCALE	N/A
MILLIMETER	± N/A	TITLE	HEAT EXCHANGER ASSEMBLY, STEAM COIL, SMALL GENERATOR
DATE	06-04-81	DRAWING NO.	C-40401
CHK.		REV.	F

CLEVELAND RANGE INC.
1333 East 178th St., Cleveland, Ohio 44116-2571

DRAWN BY A.B.K. APPROVED BY -

NOTES:
 1) REFER TO DWG. FJE0003 FOR CAL CODE
 W/INTERMITTENT BLOWDOWN FOR LARGE
 STEAM COIL GENERATOR.

Electric Box Cover
Part# S111275

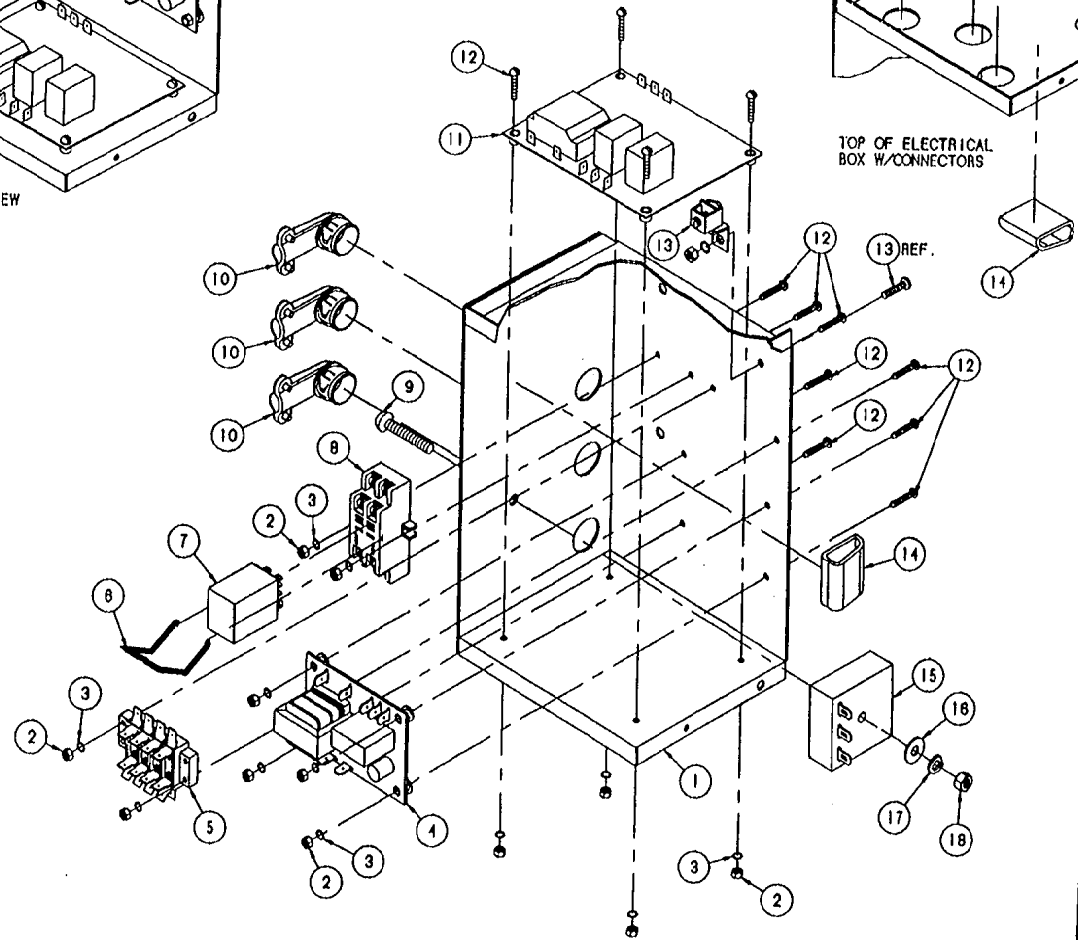
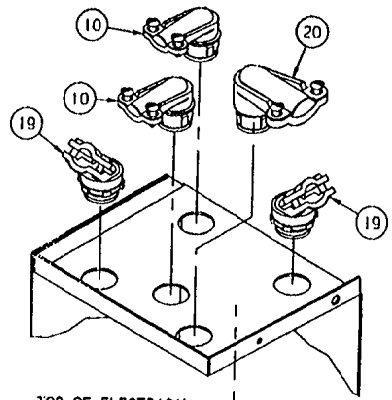
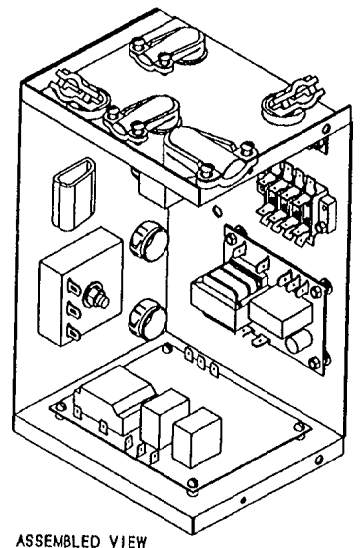

ITEM	QTY.	PART NO.	DESCRIPTION
20	1	105247	CONNECTOR, GREENFIELD, 1/2" X 90°
19	2	105244	CONNECTOR, GREENFIELD, 3/8" X 45°
18	1	14518	NUT, HEX, 1/4-20, S/S, FULL FINISHED
17	1	23105	WASHER, LOCK, MED PAT, 1/4" KATLINK STYLE, S/S
16	1	23116	WASHER, FLAT, 1/4: 10 X 5/16 OD X .065 THK
15	1	20478	TIMER, SOLID STATE INTERVAL 3 MINUTE
14	2	23432	CLIP, MOUNTING, WIRE/CALE, 1.25 X 1.50
13	1	12330	LUG, SOLDERLESS GROUND FOR 10-14 GA. WIRE
12	12	19183	SCREW, ROUND HEAD SLOTTED, 6-32 X .75 ZINC PLTD
11	1	23198	CONTROL, WATER LEVEL
10	5	105245	CONNECTOR, GREENFIELD, 3/8" X 90°
9	1	19265	SCREW, ROUND HEAD, 1/4-20 X 1-1/2, S/S
8	1	03525	SOCKET, RELAY
7	1	03524	RELAY, 120V, 50/60 HZ, AC, DPDT
6	1	105044	CLIP, WIRE, RELAY, (03524 - 03525)
5	1	44104	TERMINAL BLOCK ASM. - 4 POLE GAS UNITS
4	1	03528	BOARD CONTROL, CUT-OFF LOW WATER
3	12	23111	WASHER, LOCK, INTERNAL TOOTH, #8, ZINC PLTD
2	12	14674	NUT, HEX, 6-32, ZINC PLTD
1	1	409391	BOX, WELDMENT, ELECT, CAL CODE LG STM COIL GEN

TOLERANCES (EXCEPT AS NOTED)			
CLEVELAND RANGE INC. 1333 East 170th St. Cleveland, Ohio 44110-2574			
DECIMAL ± N/A	SCALE 1/2=1	DRAWN BY E. GRIVEAS	APPROVED BY
ANGULAR ± N/A	TITLE BOX, ELECTRIC, ASSEMBLY CAL. CODE, LARGE STEAM COIL		
CK	DATE 02-28-94	DRAWING NO. C - FJE0002	REV. -

THIS DESIGN DESCRIBES A PROPRIETARY ITEM
 AND IS THE PROPERTY OF CLEVELAND RANGE.
 THIS DRAWING IS NOT TO BE COPIED OR USED
 WITHOUT THE APPROVAL OF CLEVELAND RANGE.

OPTION FOR NEXT ASS'Y: FJE0001

LET.	REVISIONS	DATE	BY
------	-----------	------	----

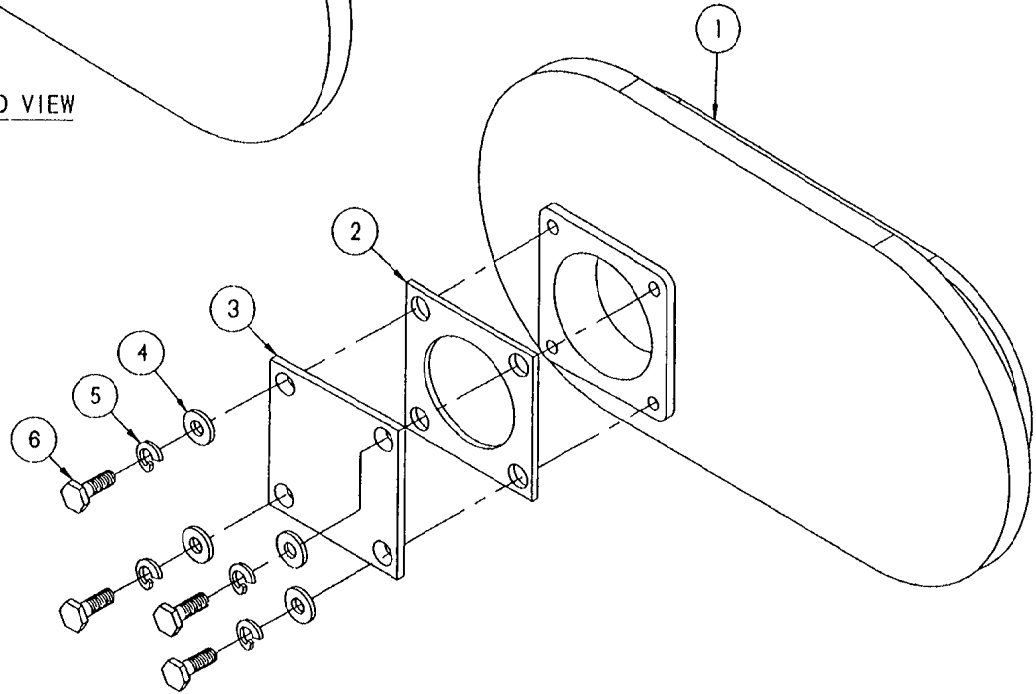
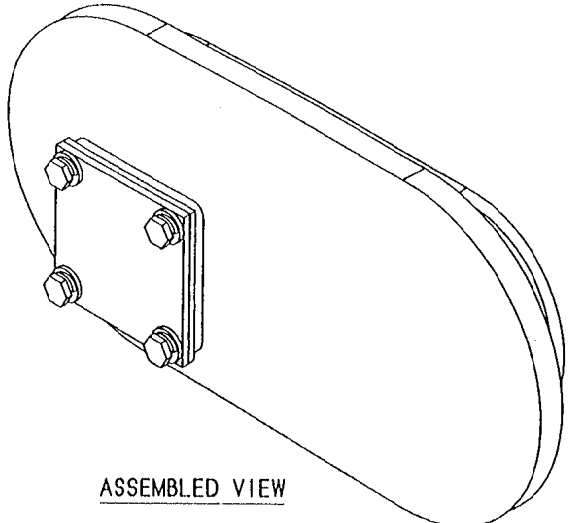

ITEM	QTY.	PART NO.	DESCRIPTION
6	4	100448	SCREW, HEX HEAD, 1/4-20 UNC-2A X 3/4
5	4	23105	WASHER, LOCK, MEDIUM PATTERN, 1/4" KATL. INK
4	4	23118	WASHER, FLAT, 1/4 X 5/8 OD. X .065 THK
3	1	16546	PLATE, BLOCK-OFF, 3.125 X 3.125
2	1	07128	GASKET
1	1	16545	PLATE, HAND HOLE

TOLERANCES (EXCEPT AS NOTED)		CLEVELAND RANGE INC. 1333 East 179th St. Cleveland, Ohio 44110-2574	
DECIMAL ± N/A	SCALE 1/2=1	DRAWN BY E. GRIVEAS	APPROVED BY NLT
ANGULAR ± N/A	TITLE PLATE, HAND HOLD, W/COVER FOR STEAM-COIL GENERATOR		
CK	DATE 11-08-93	DRAWING NO. B - 425	REV. -

THIS DESIGN DESCRIBES A PROPRIETARY ITEM AND IS THE PROPERTY OF CLEVELAND RANGE. THIS DRAWING IS NOT TO BE COPIED OR USED WITHOUT THE APPROVAL OF CLEVELAND RANGE.

NOTES:

1. REMOVE P/N 19329 WHEN CAL. CODE / LWCO IS USED (SEE B.O.M. FOR APPROPRIATE CONNECTOR). FOR CAL. CODE ELECTRIC BOX ASS'Y ON LARGE STEAM COIL GENERATOR REFER TO DWG. FJEO002.
2. REFER TO DWG. 441681 FOR ELECTRIC BOX W/INTERMITTENT BLOWDOWN.

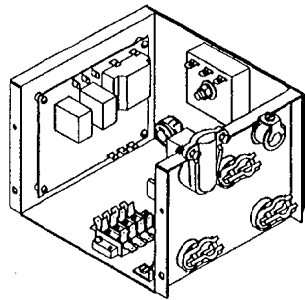

ASSEMBLED VIEW

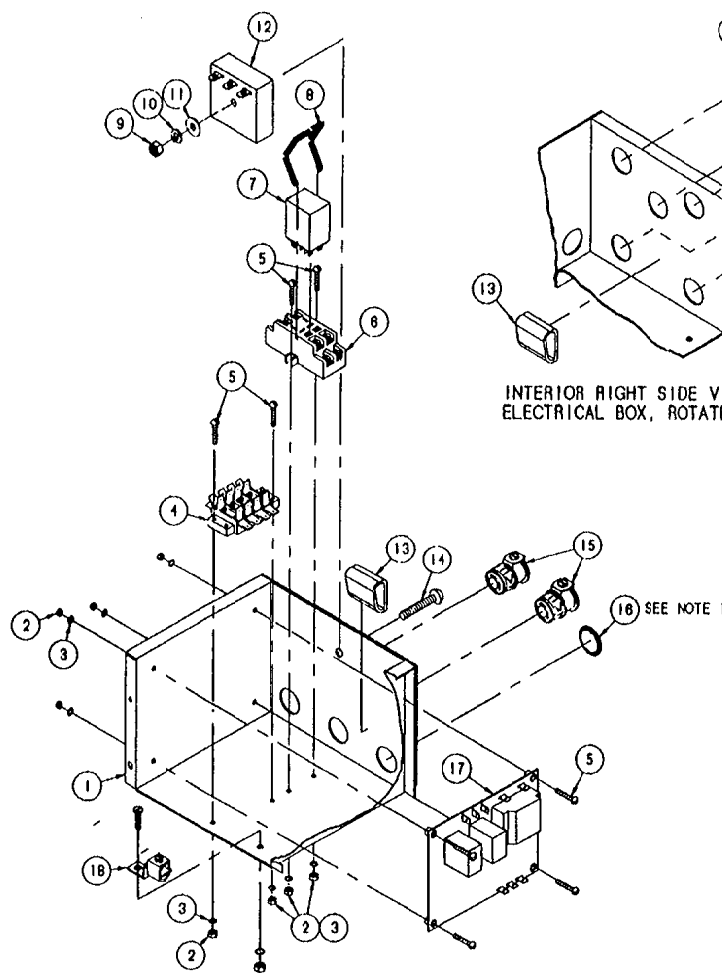
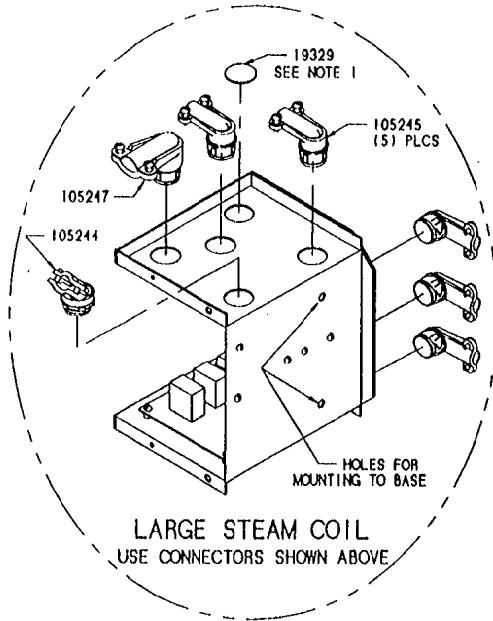

INTERIOR RIGHT SIDE VIEW OF ELECTRICAL BOX, ROTATED 90°

ITEM	QTY.	PART NO.	DESCRIPTION
20	1	105247	CONNECTOR, GREENFIELD, 1/2" X 90°
19	3	105244	CONNECTOR, GREENFIELD, 3/8" X 45°
18	1	12930	PLUG, SOLDERLESS GROUND FOR 10-14 GA. WIRE
17	1	23198	CONTROL, WATER LEVEL
16	1	19329	PLUG, SWAP-IN, 1/2" FOR 7/8" HOLE
15	3	105243	CONNECTOR, GREENFIELD, 3/8" STRAIGHT
14	1	19285	SCREW, ROUND HEAD, 1/4-20 X 1-1/2, S/S
13	2	23492	CLIP, MOUNTING, WIRE/CABLE, 1.25 X 1.50
12	1	20478	TIMER, SOLID STATE INTERVAL 3 MINUTE
11	1	23110	WASHER, FLAT, 1/4" ID X 5/8" OD X .065 THK
10	1	23105	WASHER, LOCK, MED PAT, 1/4" KATLINK STYLE, S/S
9	1	14818	NUT, HEX, 1/4-20, S/S, FULL FINISHED
8	1	105044	CLIP, WIRE, RELAY, 103524 - 035251
7	1	03524	RELAY, 120V, 50/60 HZ, AC, DPDT
6	1	03525	SOCKET, RELAY
5	8	19183	SCREW, ROUND HEAD SLOTTED, 8-32 X .75 ZINC PLTD
4	1	44184	TERMINAL BLOCK ASM. - 4 POLE GAS UNITS
3	8	23111	WASHER, LOCK, INTERNAL TOOTH, #8, ZINC PLTD
2	8	14874	NUT, HEX, 8-32, ZINC PLTD
1	1	40939	BOX, WELDMENT, ELECTRIC, STEAM COIL GENERATOR

TOLERANCES (EXCEPT AS NOTED)		CLEVELAND RANGE INC. 1333 East 179th St. Cleveland, Ohio 44110-2574	
DECIMAL ± N/A	SCALE 3/8=1	DRAWN BY E. GRIVEAS	APPROVED BY
ANGULAR ± N/A	TITLE BOX, ELECTRIC, ASSEMBLY STEAM COIL		
CK	DATE 10-20-93	DRAWING NO. C - 44166	REV. -

NEXT ASSY: DHD0011
DHE0012
DHF0013
FJEO031

THIS DESIGN DESCRIBES A PROPRIETARY ITEM AND IS THE PROPERTY OF CLEVELAND RANGE. THIS DRAWING IS NOT TO BE COPIED OR USED WITHOUT THE APPROVAL OF CLEVELAND RANGE.

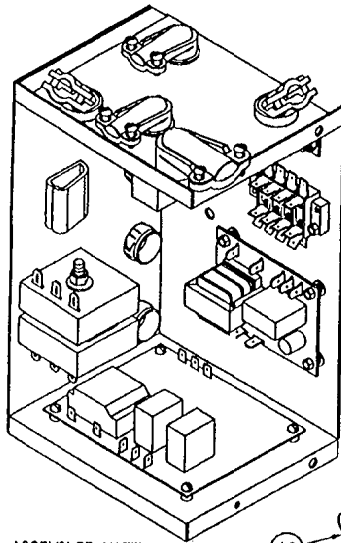

ASSEMBLED VIEW

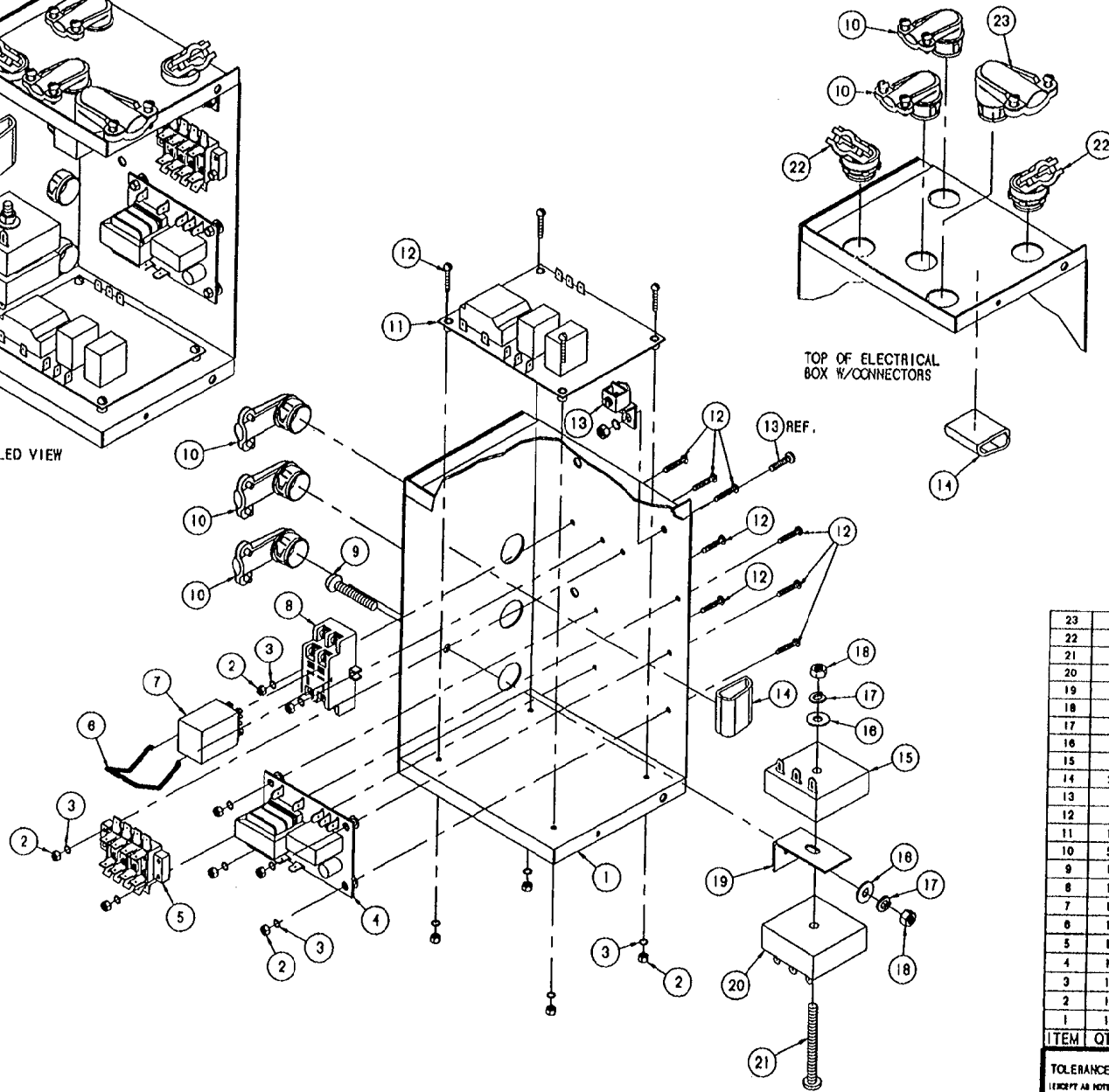

TOP OF ELECTRICAL BOX W/CONNECTORS

ITEM	QTY.	PART NO.	DESCRIPTION
23	1	105217	CONNECTOR, GREENFIELD, 1/2" X 90°
22	2	105214	CONNECTOR, GREENFIELD, 3/8" X 45°
21	1	106118	SOLT, 1/4-20 X 2-1/2" ZINC PLTD, INTRMT. TIMER
20	1	104716	TIMER, RECGLING, GENERATOR W/BLOWDOWN
19	1	105955	BRACKET, CTRL MOUNT
18	1	14618	NUT, HEX, 1/4-20, S/S, FULL FINISHED
17	1	23105	WASHER, LOCK, MED PAT, 1/4" KATLINK STYLE, S/S
16	1	23116	WASHER, FLAT, 1/4: 10 X 3/8" OD X .065 THK
15	1	20476	TIMER, SOLID STATE INTERVAL 3 MINUTE
14	2	23432	CLIP, MOUNTING, WIRE/CABLE, 1.25 X 1.50
13	1	12330	LUG, SOLDERLESS GROUND FOR 10-14 GA. WIRE
12	12	19163	SCREW, ROUND HEAD SLOTTED, 8-32 X .75 ZINC PLTD
11	1	23198	CONTROL, WATER LEVEL
10	3	105245	CONNECTOR, GREENFIELD, 3/8" X 90°
9	1	19285	SCREW, ROUND HEAD, 1/4-20 X 1-1/2, S/S
8	1	03525	SOCKET, RELAY
7	1	03524	RELAY, 120V, 50/60 HZ, AC, DPDT
6	1	105044	CLIP, WIRE, RELAY, (03524 - 03525)
5	1	44184	TERMINAL BLOCK ASM, - 4 POLE GAS UNITS
4	1	03526	BOARD CONTROL, CUT-OFF LOW WATER
3	12	23111	WASHER, LOCK, INTERNAL TOOTH, #8, ZINC PLTD
2	12	14674	NUT, HEX, 8-32, ZINC PLTD
1	1	409391	BOX, WELDMENT, ELECT, CAL CODE LG STM COIL GEN

TOLERANCES (EXCEPT AS NOTED)			
DECIMAL	SCALE	DRAWN BY	APPROVED BY
± N/A	1/2=1	E. GRIVEAS	
ANGULAR	TITLE		
± N/A	BOX, ELECTRIC, ASSEMBLY CAL. CODE W/INTER. BLOWDOWN, LARI. .AM COIL		
DATE	DRAWING NO.	REV.	

THIS DESIGN DESC AND IS THE PROPRIETARY ITEM OF CLEVELAND RANGE. THIS DRAWING IS N/A. BE COPIED OR USED WITHOUT THE APPROVAL OF CLEVELAND RANGE.

OPTION FOR NEXT ASS'Y: FJL0001

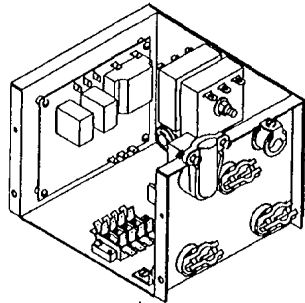

ASSEMBLED VIEW

NOTES:
 1. REMOVE P/N 19329 WHEN CAL. CODE / LWCO IS USED (SEE B.O.M. FOR APPROPRIATE CONNECTOR). FOR CAL. CODE ELECTRIC BOX ASS'Y ON LARGE STEAM COIL GENERATOR REFER TO DWG. FJE0002.

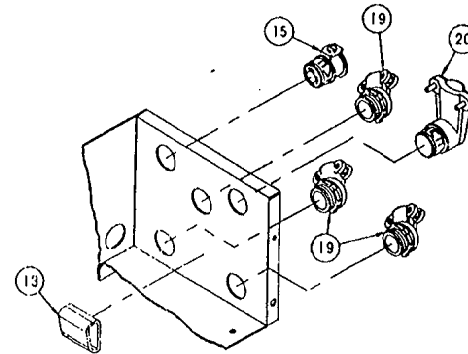

INTERIOR RIGHT SIDE VIEW OF ELECTRICAL BOX, ROTATED 90°

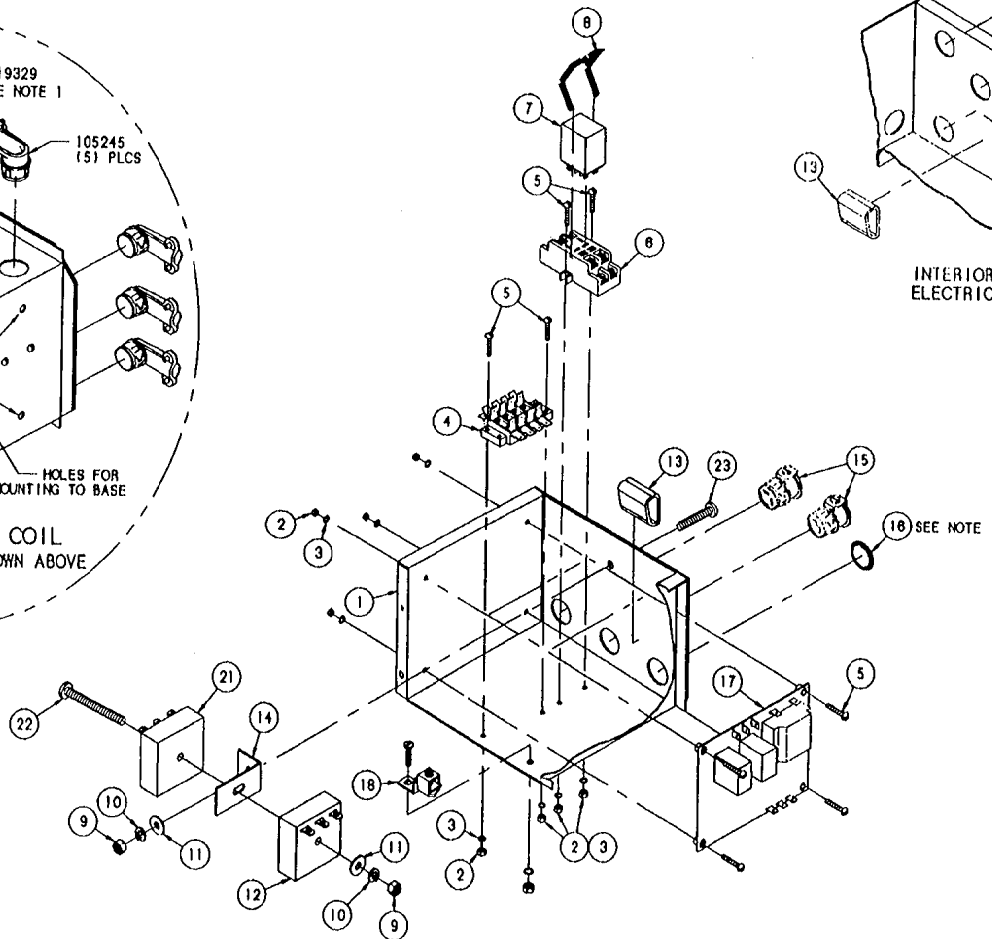
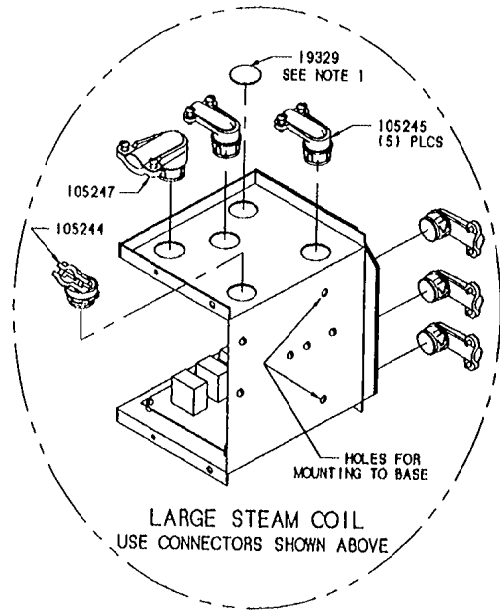

ITEM	QTY.	PART NO.	DESCRIPTION
23	1	19285	SCREW, ROUND HEAD, 1/4-20 X 1-1/2, S/S
22	1	100118	BOLT, 1/4-20 X 2-1/2" ZINC PLTD, INTFRM. TIMER
21	1	104718	TIMER, RECYCLING, GENERATOR W/BLOWDOWN
20	1	105247	CONNECTOR, GREENFIELD, 1/2" X 90°
19	3	105244	CONNECTOR, GREENFIELD, 3/8" X 45°
18	1	12330	LUG, SOLDERLESS GROUND FOR 10-14 GA. WIRE
17	1	23198	CONTROL, WATER LEVEL
16	1	19329	PLUG, SNAP-IN, 1/2" FOR 7/8" HOLE
15	3	105243	CONNECTOR, GREENFIELD, 3/8" STRAIGHT
14	1	105955	BRACKET, CTRL MOUNT
13	2	23432	CLIP, MOUNTING, WIRE/CABLE, 1.25 X 1.50
12	1	20478	TIMER, SOLID STATE INTERVAL 3 MINUTE
11	2	23118	WASHER, FLAT, 1/4: 10 X 5/8" OD X .095 THK
10	2	23105	WASHER, LOCK, MED PAT, 1/4" KATLINK STYLE, S/S
9	2	14818	NUT, HEX, 1/4-20, S/S, FULL FINISHED
8	1	105044	CLIP, WIRE, RELAY, 103524 - 03525
7	1	03524	RELAY, 120V, 50/60 HZ, AC, DPDT
6	1	03525	SOCKET, RELAY
5	8	19183	SCREW, ROUND HEAD SLOTTED, 8-32 X .75 ZINC PLTD
4	1	44184	TERMINAL BLOCK ASM. - 4 POLE GAS UNITS
3	8	23111	WASHER, LOCK, INTERNAL TOOTH, 1/8, ZINC PLTD
2	8	14874	NUT, HEX, 8-32, ZINC PLTD
1	1	40939	BOX, WELDMENT, ELECTRIC, STEAM COIL GENERATOR

THIS DESIGN DESCRIBES A PROPRIETARY ITEM AND IS THE PROPERTY OF CLEVELAND RANGE. THIS DRAWING IS NOT TO BE COPIED OR USED WITHOUT THE APPROVAL OF CLEVELAND RANGE.

NEXT ASSY: DHD0011
 DHE0012
 DIF0013
 FJE0001

TOLERANCES (UNLESS AS NOTED)			CLEVELAND RANGE INC. 1333 East 179th St. Cleveland, Ohio 44110-2574	
DECIMAL ± N/A	SCALE 3/8=1	DRAWN BY E. GRIVEAS	APPROVED BY	
ANGULAR ± N/A	TITLE BOX, ELECTRIC, STEAM COIL W/INTERMITTENT BLOWDOWN			
CK	DATE 11-18-93	DRAWING NO. C - 441661	REV.	

LET.	REVISIONS	DATE	BY
A	REMOVED 14359 ADDED 14343 REARRANGED ASSEMBLY	5-19-92	SM

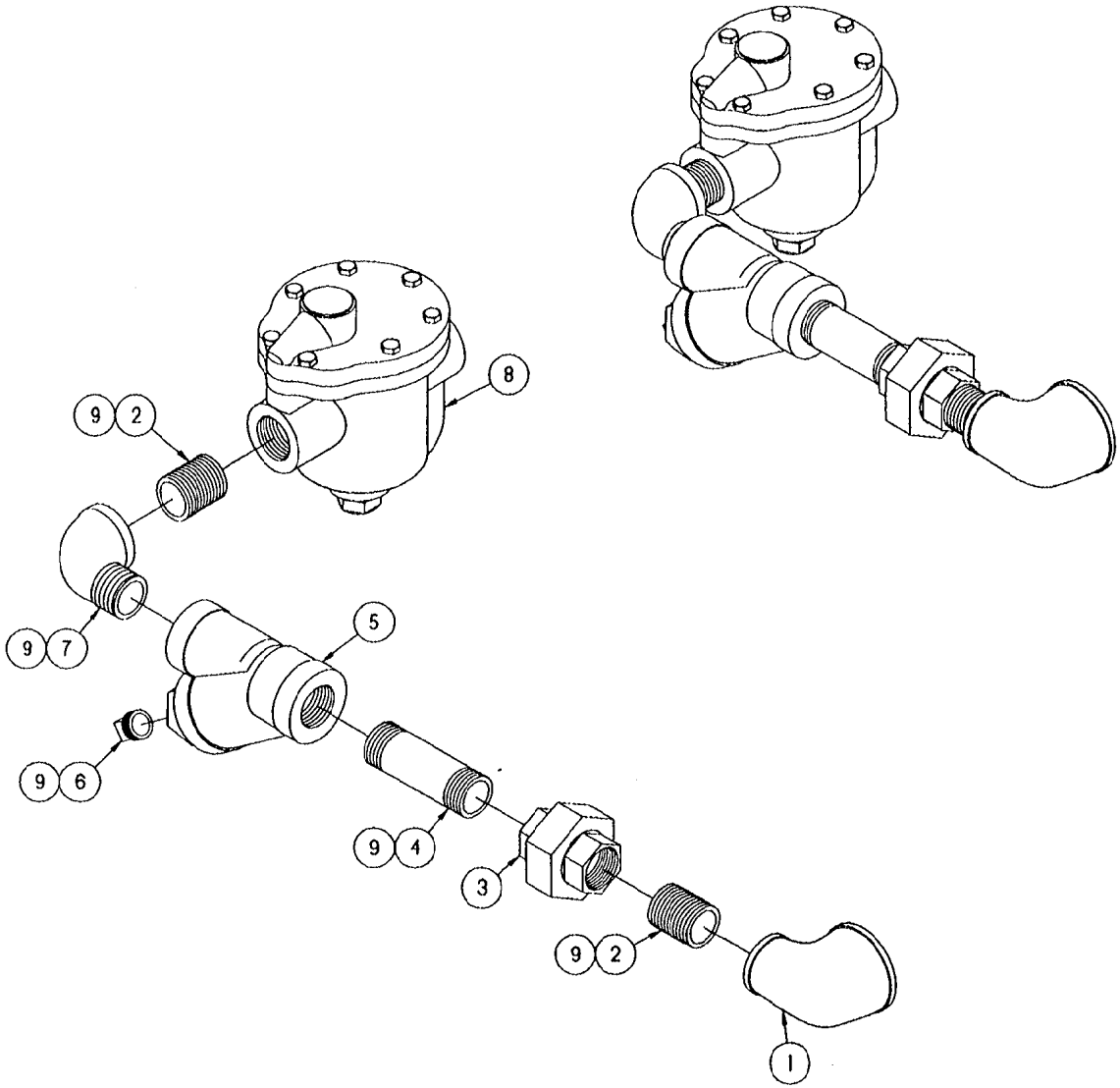

ITEM	QTY.	PART NO.	DESCRIPTION
9	A/R	00934	SEALANT, RECTORSEAL
8	1	20555	TRAP, BUCKET, 60#, 3/4, 80#
7	1	05259	ELBOW, STREET, 90°, 3/4, BLACK
6	1	16602	PLUG, SQ HD, 1/2", CORED
5	1	19872	STRAINER, "Y", 3/4
4	1	14347	NIPPLE, 3/4 x 3", BLACK
3	1	21305	UNION, 3/4, BLACK
2	2	14343	NIPPLE, 3/4 x CLOSE, BLACK
1	1	05270	ELBOW, 90°, 1-1/4 x 3/4, BLACK

TOLERANCES (EXCEPT AS NOTED)		CLEVELAND RANGE INC. 1333 East 179th St. Cleveland, Ohio 44110-2574	
DECIMAL ± N/A	SCALE 3/8=1	DRAWN BY S. MILEWSKI	APPROVED BY
ANGULAR ± N/A	TITLE PIPING ASSEMBLY RETURN STEAM MANIFOLD LARGE STEAM COIL GENERATOR		
CK	DATE 05-13-92	DRAWING NO. B - 01703	REV. A

THIS DESIGN DESCRIBES A PROPRIETARY ITEM AND IS THE PROPERTY OF CLEVELAND RANGE. THIS DRAWING IS NOT TO BE COPIED OR USED WITHOUT THE APPROVAL OF CLEVELAND RANGE.

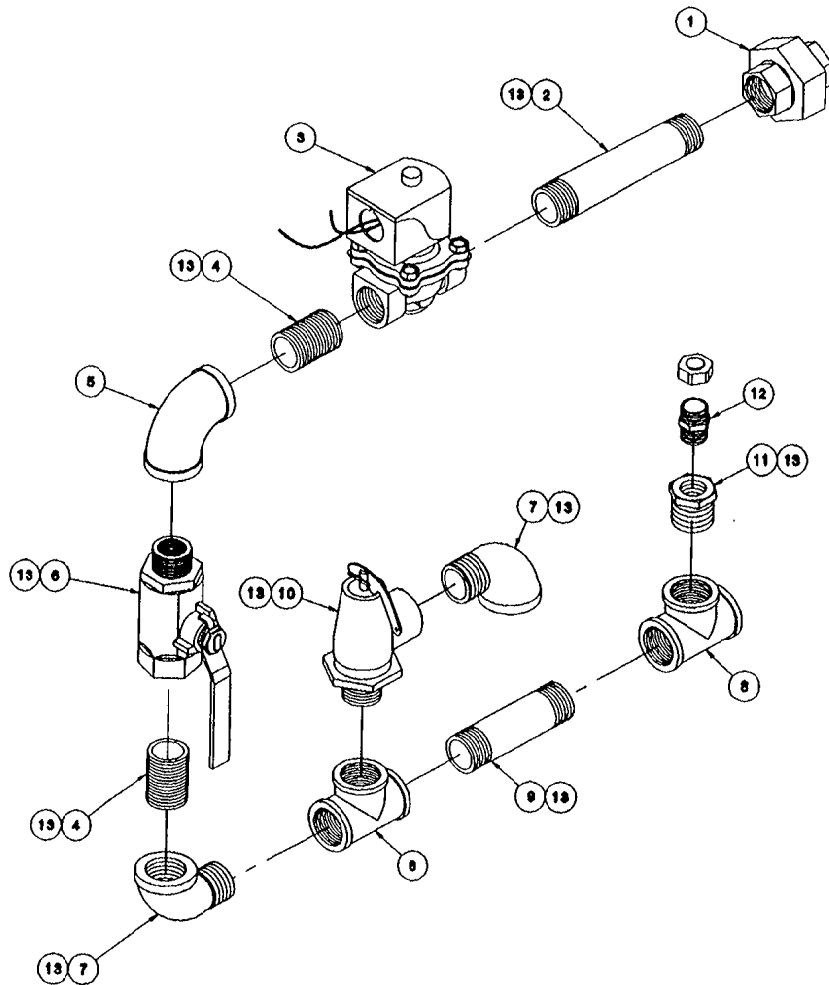

LET	REVISIONS	DATE	BY
C	P/N 14354 WAS 14356, P/N 14349 WAS 14351. P/N 02584 WAS 02583. P/N 06199 WAS 06218. P/N 03382 WAS ADDED - REDRAWN ON COMPUTER SEE E.O. #C-1789	09-20-90	GS
D	P/N 05259 WAS QTY. OF 1 P/N 00934 WAS ADDED P/N 03382 WAS OMITTED DWG. REDRAWN IN 3D CADKEY SEE E.O. #C-2106	01-29-92	PJD
E	P/N 03277 VALVE ROTATED 90°	11-16-93	PJD

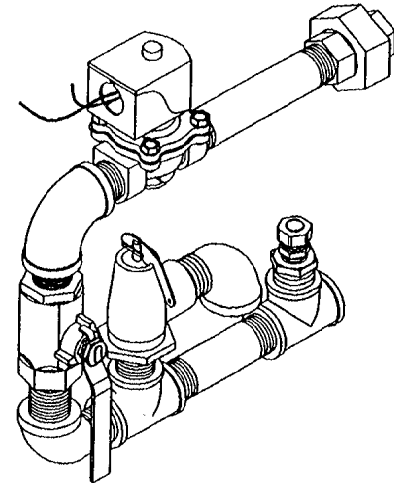

KE54941-2

13	A/R	00934	SEALANT, RECTORSEAL
12	1	06199	FITTING, COMP, 3/8 x 3/8, STR
11	1	02584	BUSHING, HEX, 3/4 x 3/8, BLK
10	1	100076	VALVE, SAFETY RELIEF, 50 PSI
9	1	14349	NIPPLE, 3/4 X 3.500, BLACK
8	2	20205	TEE, 3/4, BLACK
7	2	05259	ELBOW, STREET, 90° X 3/4, BLK.
6	1	03277	VALVE, BALL, 3/4, BRASS
5	1	05258	ELBOW, 90°, 3/4, BLACK
4	2	14343	NIPPLE, 3/4 X CLOSE, BLACK
3	1	22193	VALVE, SOLINOID, 3/4, 50 PSI
2	1	14354	NIPPLE, BLACK 3/4" X 5.00"
1	1	21305	UNION, BLACK, 3/4"
NO.	QTY.	PART NO.	DESCRIPTION
TOLERANCES (UNLESS OTHERWISE SPECIFIED)			
CLEVELAND RANGE INC. 1333 East 179th St., Cleveland, Ohio 44110-2574			
DECIMAL ± N/A	SCALE 1/2"=1	DRAWN BY DUTCHMAN	APPROVED BY
ANGULAR ± N/A	TITLE STEAM SUPPLY VALVE STEAM COIL PIPING ASSY.		
CK	DATE 01-29-92	DRAWING NO. C - 42809	REV. E

THIS DESIGN DESCRIBES A PROPRIETARY ITEM AND IS THE PROPERTY OF CLEVELAND RANGE. THIS DRAWING IS NOT TO BE COPIED OR USED WITHOUT THE APPROVAL OF CLEVELAND RANGE.

NOTE: 1. MOUNT P/N 100084 TO LOWER RIGHT FRONT SUSSET (BASE FRAME).

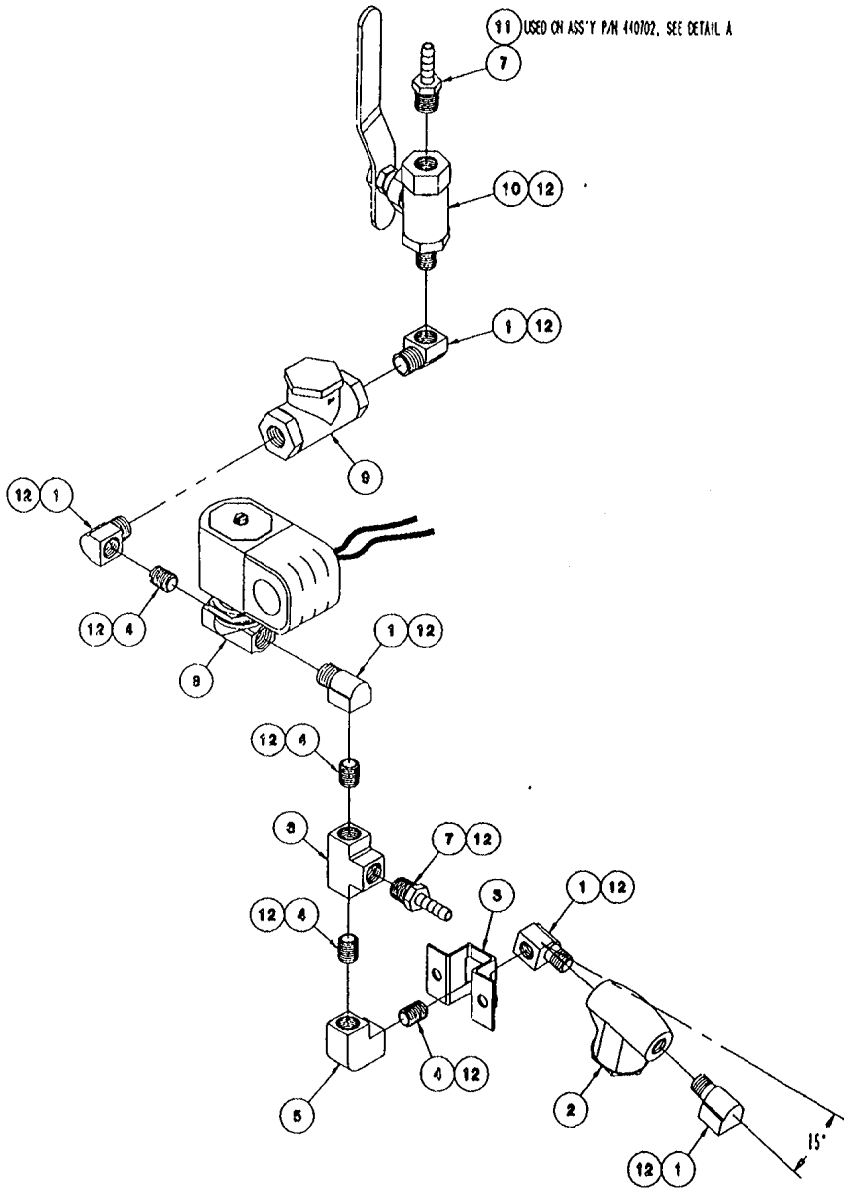

11 USED ON ASS'Y P/N 440702, SEE DETAIL A

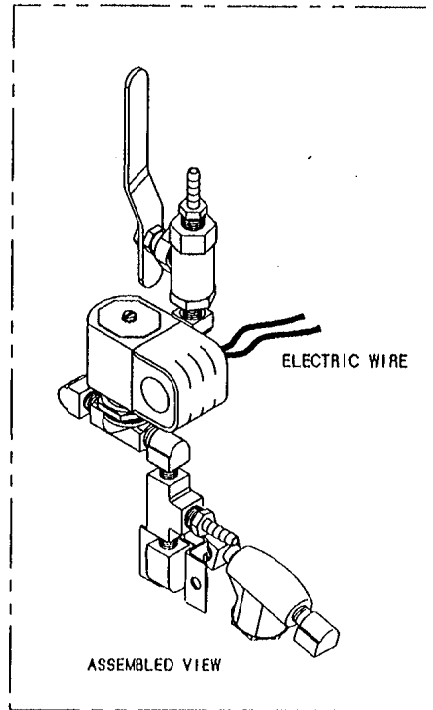

LET.	REVISIONS	DATE	BY
A	REDRAWN - WAS COMBINED w/ 44070 & 440702. CHANGED ASSY ANGLE ORIENTATIONS.	1-21-92	SM
B	NEW VALVE HOUSING ON P/N 22223 (PICTORIAL ONLY) PER E.O. IC-2221 R1.	02-04-93	PJD
C	P/N 22223 REVISED PICTORIALLY P/N'S 18819 & 08218 OMITTED ADDED P/N 104381, AND ADDED ASSY 440702 PER E.O. IC-2448	08-18-93	EAG

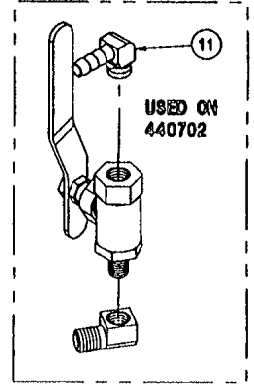

A/R	A/R	12	PART NO.	DESCRIPTION
			00934	SEALANT, RECTORSEAL
			105788	FITTING, HOSEBARB, 1/4H X 1/4MPT, 90°
			03278	VALVE, BALL, 1/4
			22102	VALVE, SWING CHECK, 1/4
			22223	VALVE, SOLENOID, 1/4 (GP200)
			104381	FITTING, HOSE, 1/4 H X 1/4 NPT
			20199	TEE, 1/4, BRASS
			05236	ELBOW, 1/4, 90°, BRASS
			14304	NIPPLE, 1/4 X CLOSE, BRASS
			100084	CLAMP, MOUNTING
			19870	STRAINER, "V", 1/4, BRASS
			05235	ELBOW, STREET, 1/4, 90°, BRASS
QTY.	QTY.	NO.	PART NO.	DESCRIPTION

SEE NOTE 1

THIS DESIGN DESCRIBE... RIETARY ITEM AND IS THE PROPERTY C... ELAND RANGE. THIS DRAWING IS NOT TO BE COPIED OR USED WITHOUT THE APPROVAL OF CLEVELAND RANGE

TOLERANCES (EXCEPT AS NOTED) DECIMAL ± 1/4 ANGULAR ± 1°				CLEVELAND RANGE INC. 1333 East 179th St. Cleveland, Ohio 44110-2574	
SCALE 1/2=1	DRAWN BY S. MILEWSKI	APPROVED BY			
TITLE PIPING ASSY., "V" STEAM COIL AND		FEED JRES			
DATE 01-21-92	DRAWING NO. C - 440701	440702	440702	REV	C

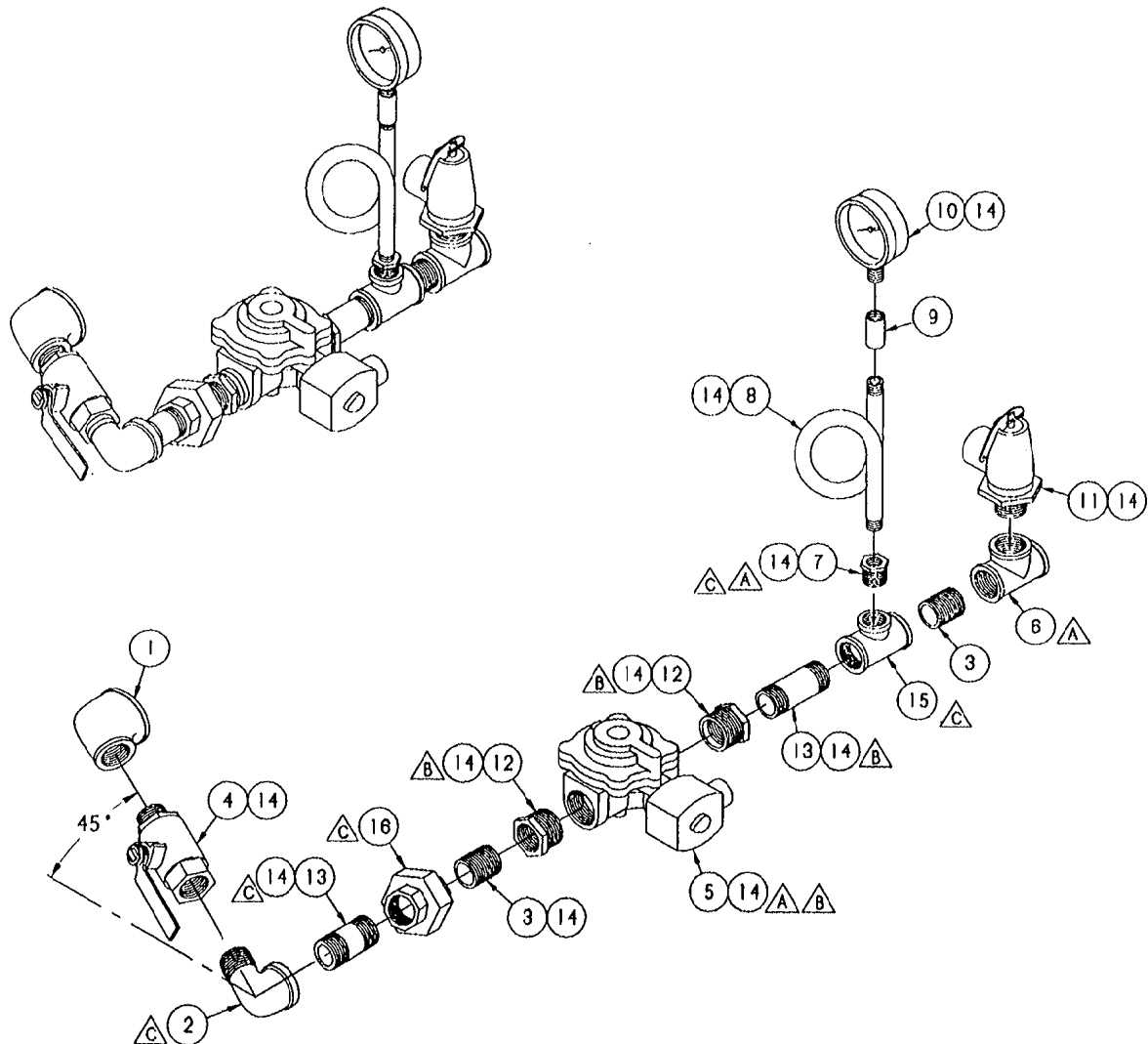

LET.	REVISIONS	DATE	BY
A	REMOVED 05259, 21305, 02557, 20209, 02570 REPLACED 101899 WITH 22193 ADDED 05263, 20205, 02582	5-19-92	SM
B	CHANGED 101899 FROM 22193 ADDED 02598, 14345	7-20-92	SM
C	ADDED 21305 & 20209; 02557 WAS 02562; 14344 WAS 14345; 05259 WAS 05263; 20205 WAS QTY 12)	12-2-93	EAG

△C	16	1	21305	UNION, PIPE, 3/4" BLK. NO WARWICKS
△C	15	1	20209	TEE, 3/4" X 3/4" x 1/2, BLACK
	14	A/R	00934	SEALANT, RECTORSEAL
△C	13	2	14344	NIPPLE, 3/4 x 2", BLACK
△B	12	2	02598	BUSHING, HEX, 1" x 3/4, BLACK
	11	1	100075	VALVE, BOILER SAFTEY, 50 PSI
	10	1	07169	GUJAGE, 0-100 PSI, 1/4 NPT
	9	1	03665	COUPLING, FULL, 1/4, S/S
	8	1	16820	PIPE, PIGTAIL, 1/4
△C	7	1	02557	BUSHING, 1/2 x 1/4, BLACK
△C	6	1	20205	TEE, 3/4, BLACK
△B	5	1	101899	VALVE, STEAM SOLENOID, 1" NPT
	4	1	03277	VALVE, BALL, 3/4, BRASS
	3	2	14343	NIPPLE, 3/4 x CLOSE, BLACK
△C	2	1	05259	ELBOW, STREET, 90°, 3/4, BLACK
	1	1	05270	ELBOW, 90°, 1-1/4 x 3/4, BLACK
	ITEM	QTY.	PART NO.	DESCRIPTION

TOLERANCES
(EXCEPT AS NOTED)

CLEVELAND RANGE INC.
1333 East 179th St. Cleveland, Ohio 44110-2574

DECIMAL
± N/A

SCALE
1/4=1

DRAWN BY
S. MILEWSKI

APPROVED BY

ANGULAR
± N/A

TITLE
PIPING ASSEMBLY - STEAM SUPPLY
LARGE STEAM COIL GENERATOR

CK

DATE
05-13-92

DRAWING NO.
B - 101723

REV.
C

THIS DESIGN DESCRIBES A PROPRIETARY ITEM AND IS THE PROPERTY OF CLEVELAND RANGE. THIS DRAWING IS NOT TO BE COPIED OR USED WITHOUT THE APPROVAL OF CLEVELAND RANGE.

LET.	REVISIONS	DATE	BY
A	REPLACED 14494 WITH 14355 70413 WITH 03732 REMOVED 101708, 05231, 02570 QTY 2	5-19-92	SM
B	REMOVED P/N 03732 ADDED P/N 20208, 14342	7-17-92	SM
C	REMOVED 02563, 20208 & 14342; ADDED 70413, 101708; 14494 WAS 14355; 02570 WAS QTY (1)	12-03-93	EAG

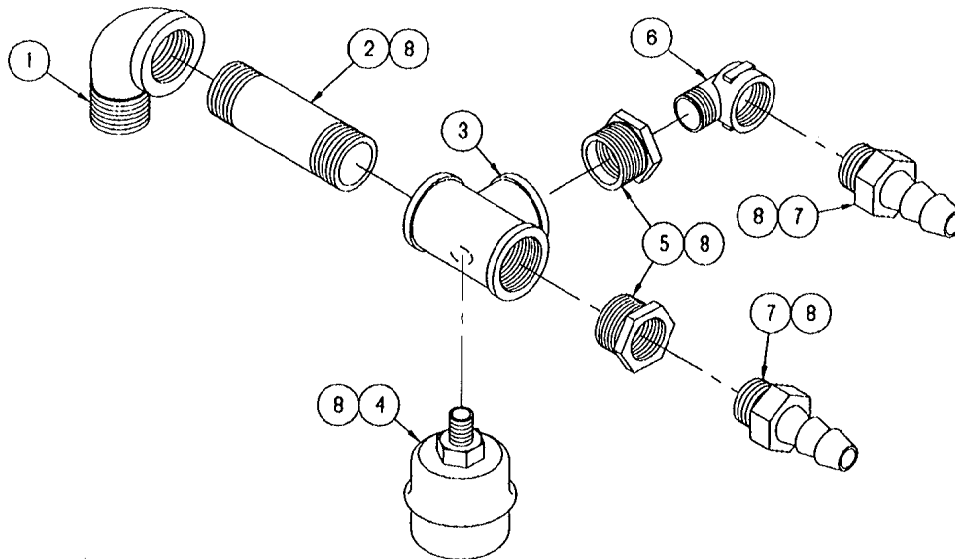
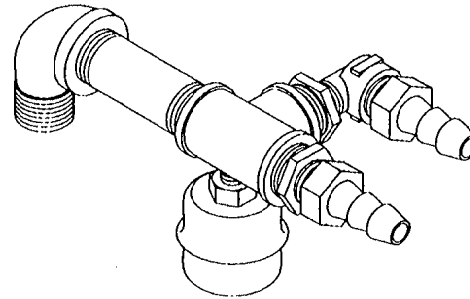

8	A/R	00934	SEALANT, RECTORSEAL
7	2	08240	FITTING, HOSE BARB, 3/4 H x 3/4
6	1	05231	ELBOW, STREET, 90°, 3/4, BRASS
5	2	02570	BUSHING, HEX, 1" X 3/4", BRASS
4	1	101207	TRAP, THERMOSTATIC, 1/4 NPT
3	1	70413	TEE, 1", BRASS - MODIFIED (PCL ST COIL)
2	1	14494	NIPPLE, 1 X 4, BRASS
1	1	101708	ELBOW, STREET, 90°, 1", BRASS
ITEM	QTY.	PART NO.	DESCRIPTION

TOLERANCES (EXCEPT AS NOTED)		CLEVELAND RANGE INC. 1333 East 179th St. Cleveland, Ohio 44110-2574		
DECIMAL ± N/A	SCALE 3/8=1	DRAWN BY S. MILEWSKI	APPROVED BY	
ANGULAR ± N/A	TITLE PIPING ASSM, STEAM OUTLET PCL, STEAM COIL GENERATOR			
CK	DATE 05-13-92	DRAWING NO. B - 101724	REV. C	

THIS DESIGN DESCRIBES A PROPRIETARY ITEM AND IS THE PROPERTY OF CLEVELAND RANGE. THIS DRAWING IS NOT TO BE COPIED OR USED WITHOUT THE APPROVAL OF CLEVELAND RANGE.

LET	REVISIONS	DATE	BY
A	ITEM 3 WAS 14382 & 7.500 ITEM 5 WAS 14388 & 10.500 REDRAWN - E.O. #C-1994	08-08-91	PJD

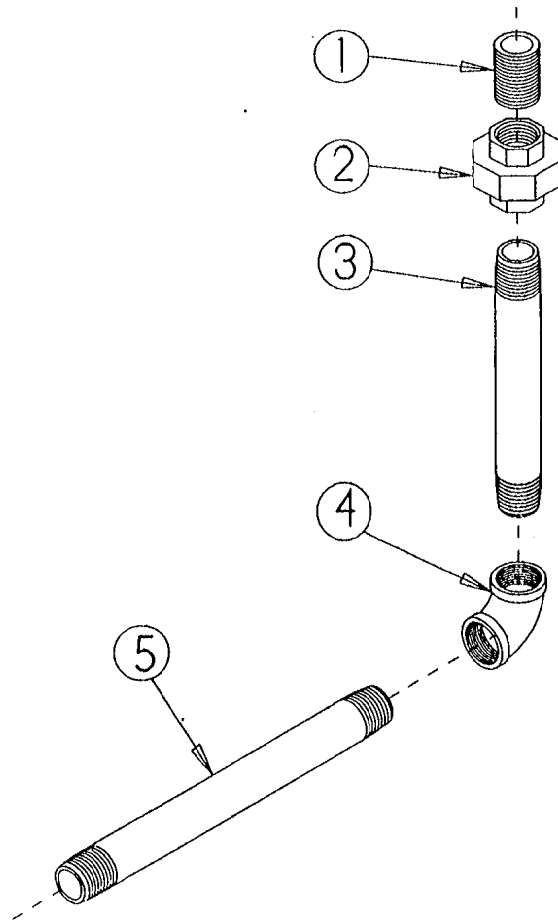

ASSEMBLED UNIT

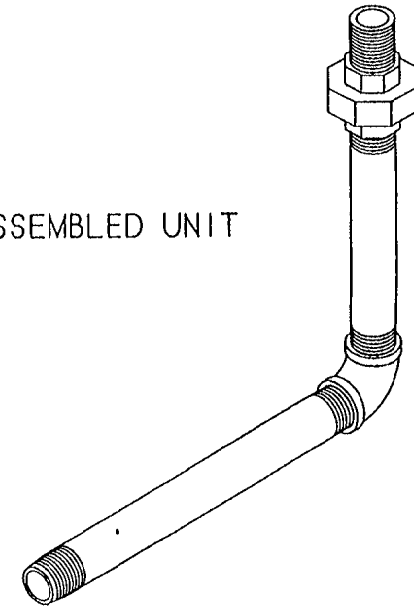

NO.	QTY.	PART NO.	DESCRIPTION
5	1	14388	NIPPLE, 3/4 NPT X 10.00 BLACK
4	1	05258	ELBOW, 3/4 X 90° BLACK
3	1	14380	NIPPLE, 3/4 NPT X 7.00 BLACK
2	1	21305	UNION, 3/4 NPT BLACK
1	1	14343	NIPPLE, CLOSE, 3/4 NPT BLACK

TOLERANCES
(EXCEPT AS NOTED)

DECIMAL ± N/A	SCALE 1/2"	DRAWN BY J.J.	APPROVED BY
ANGULAR ± N/A	TITLE PIPING ASS'Y. STEAM SUPPLY - STEAM COIL REVERSE BEND		
CK	DATE 10-31-84	DRAWING NO. C-42808	REV. A

THIS DESIGN DESCRIBES A PROPRIETARY ITEM AND IS THE PROPERTY OF CLEVELAND RANGE. THIS DRAWING IS NOT TO BE COPIED OR USED WITHOUT THE APPROVAL OF CLEVELAND RANGE.

CLEVELAND RANGE INC.
1333 East 179th St. Cleveland, Ohio 44110-2574

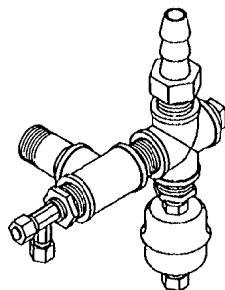

ASSEMBLED VIEW

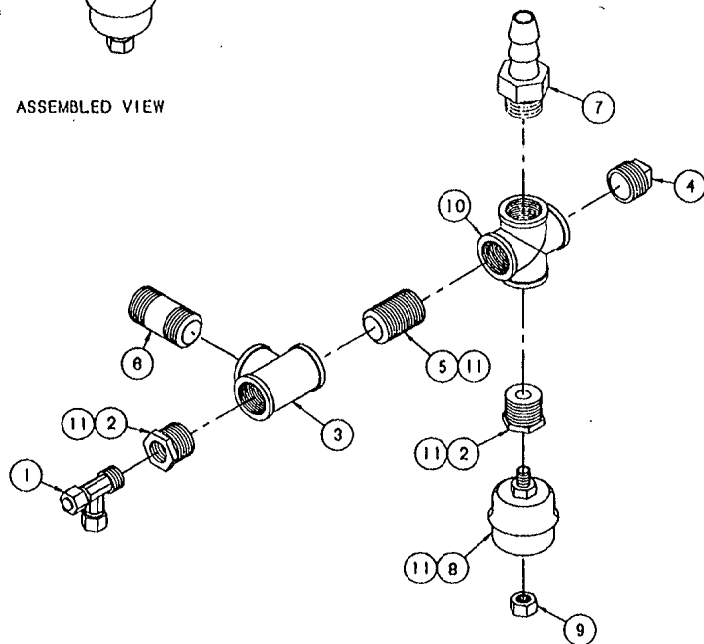

REF.	REVISIONS	DATE	BY
A	ITEM 4 WAS P/N 06206		
B	ITEM 1 & 2 CHANGED POSITION W/ ITEM 8		
C	ITEMS 1, 2 & 8 RETURNED TO ORIGINAL POSITION. E.O. - 1851	12-10-90	GS
D	REDRAWN ON CADKEY ONLY CHANGE	10-13-93	EG

ITEM	QTY.	PART NO.	DESCRIPTION
11	A/R	00934	SEALANT, RECTORSEAL
10	1	03732	CROSS, 4-WAY 3/4" BRASS
9	1	14661	NUT, COMPRESSION, 1/4" TUBE, BRASS
8	1	101207	TRAP, THERMOSTATIC, 1/4" X 1/4"
7	1	08240	FITTING, HOSE BARB, 3/4" HOSE X 3/4" MPT BRASS
6	1	14431	NIPPLE, 3/4 X 2, BRASS
5	1	14342	NIPPLE, 3/4 X CLOSE, BRASS
4	1	18607	PLUG, SQUARE HEAD, 3/4, BRASS
3	1	20206	TEE, 3/4 BRASS
2	2	02583	BUSHING, REDUCING, 3/4 X 1/4, BRASS
1	1	100883	FITTING, COMP., TEE 3/8T X 3/8MPT X 3/8T

TOLERANCES (UNLESS AS NOTED)		CLEVELAND RANGE INC. 1333 East 179th St. Cleveland, Ohio 44110-2974	
DECIMAL ± N/A	SCALE 1/2"=1"	DRAWN BY GS	APPROVED BY
FRACTIONAL ± N/A	TITLE STEAM OUTLET ASSEMBLY 21CSM	DATE 12-3-90	
CK	DRAWING NO. C - 428123		

THIS DESIGN DESCRIBES A PROPRIETARY ITEM AND IS THE PROPERTY OF CLEVELAND RANGE. THIS DRAWING IS NOT TO BE COPIED OR USED WITHOUT THE APPROVAL OF CLEVELAND RANGE.

LET	REVISIONS	DATE	BY
A	ITEM 1 WAS QTY. OF 4 ITEM 3 WAS QTY. OF 1 ADDED ITEM 7 - PLUG REDRAWN - E.O. #C-1994	08-08-91	PJD

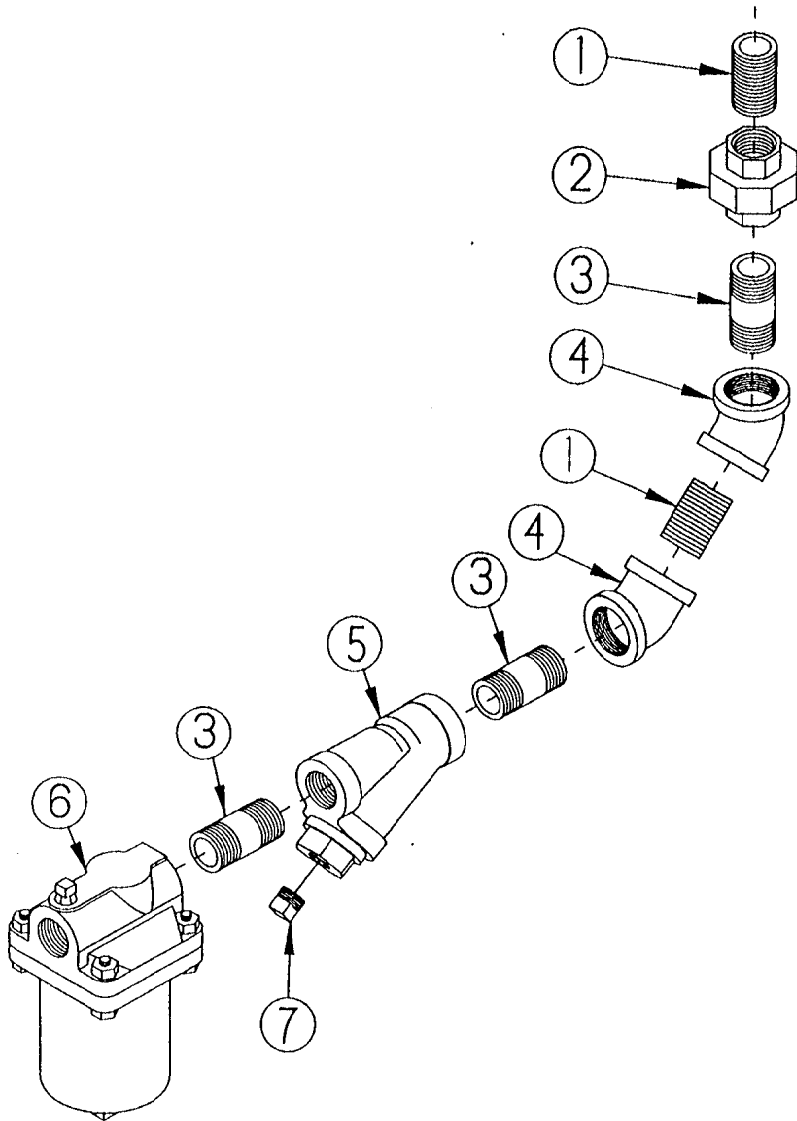

ASSEMBLED UNIT

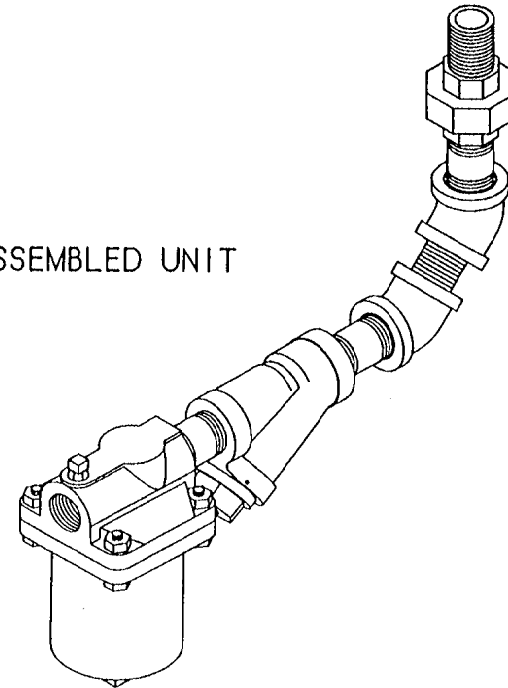

NO.	QTY.	PART NO.	DESCRIPTION
7	1	18801	PLUG, SQUARE HEAD 3/8" PIPE BLACK
6	1	20555	TRAP, BUCKET #80 3/4-80#
5	1	19872	STRAINER, 3/4 NPT BLACK
4	2	05282	ELBOW, 3/4 X 45° BLACK
3	3	14344	NIPPLE, 3/4 NPT X 2.00 BLACK
2	1	21305	UNION, 3/4 NPT BLACK
1	2	14343	NIPPLE, CLOSE, 3/4 NPT BLACK

NO.	QTY.	PART NO.	DESCRIPTION
TOLERANCES <small>(EXCEPT AS NOTED)</small>			
CLEVELAND RANGE INC. 1333 East 179th St. Cleveland, Ohio 44110-2571			
DECIMAL	SCALE 1/2"	DRAWN BY J.J.	APPROVED BY -
± N/A			
ANGULAR	TITLE PIPING ASS'Y, CONDENSATE DRAIN - STEAM COIL REVERSE BEND		
± N/A	DATE	DRAWING NO.	REV.

THIS DESIGN DESCRIBES A PROPRIETARY ITEM AND IS THE PROPERTY OF CLEVELAND RANGE. THIS DRAWING IS NOT TO BE COPIED OR USED

LET.	REVISIONS	DATE	BY
-	PRODUCTION RELEASE E.O. 4C-1994	08-23-91	PJD
A	P/N 14317 & 20205 OMITTED AND P/N 08210 WAS QTY. OF 2 PER E.O. 4C-2448	08-22-93	PJD

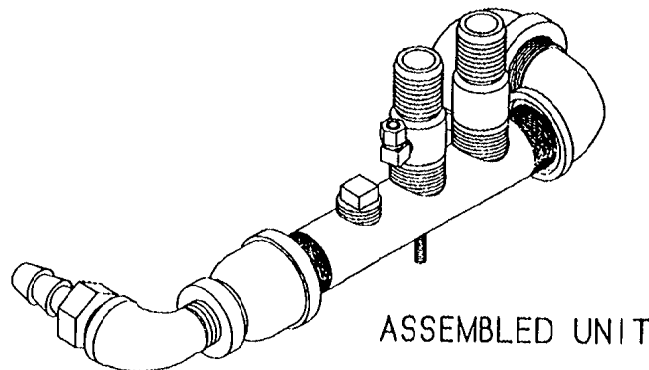
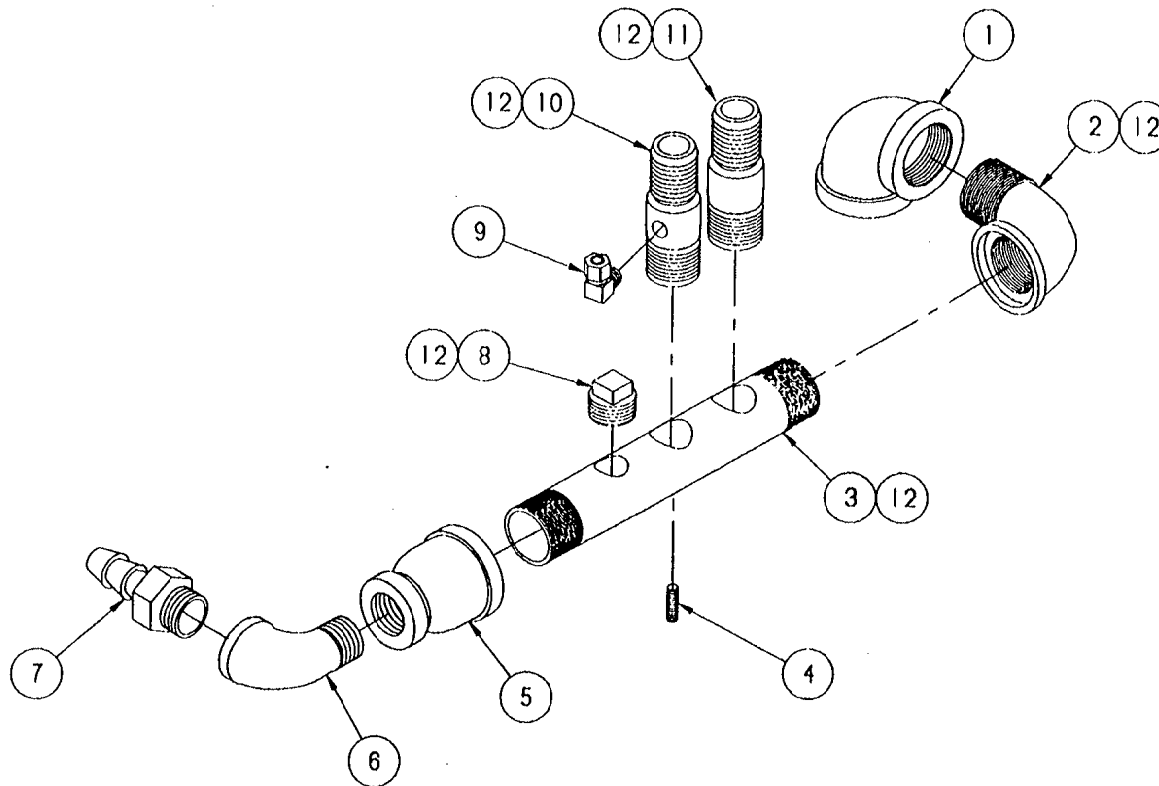

12	M/R	00934	SEALANT, RECTORSEAL
11	I	14481	FITTING, BARB 1" H X 1" MPT S/S
10	I	585191	FITTING, HOSE, DRAIN MANIFOLD W/ 1/8 HOLE
9	I	08192	FITTING, COMP. 1/4 T X 1/8 MPT 90°
8	I	16808	PLUG, SQ. HEAD, 3/4" PIPE, BLACK
7	I	08240	FITTING, HOSE BARB 3/4 H X 3/4 MPT
6	I	05259	ELBOW, STREET 3/4 X 90°, BLACK
5	I	03818	COUPLING, RED. 1-1/2 X 3/4, BLACK
4	I	19917	STUD, WELD 1/4-20 X 7/8, S/S
3	I	13252	MANIFOLD, DRAIN 1-1/2 NPT, BLACK
2	I	05292	ELBOW, STREET 1-1/2 NPT X 90° BLACK
1	I	05238	ELBOW, 1-1/2 NPT X 90°, BLACK
ITEM	QTY.	PART NO.	DESCRIPTION

TOLERANCES (EXCEPT AS NOTED)		CLEVELAND RANGE INC. 1333 East 179th St. Cleveland, Ohio 44110-2574	
DECIMAL ± N/A	SCALE 1/2"	DRAWN BY P. J. D.	APPROVED BY
ANGULAR ± N/A	TITLE PIPING ASSEMBLY DRAIN 38CGM/SM, 38CGM/LG, 3. 24CSM, 36CSM		
CK	DATE 08-13-91	DRAWING NO. C - 42751	REV. A

THIS DESIGN DESCRIBES A PROPRIETARY ITEM AND IS THE PROPERTY OF CLEVELAND RANGE. THIS DRAWING IS NOT TO BE COPIED OR USED WITHOUT THE APPROVAL OF CLEVELAND RANGE.

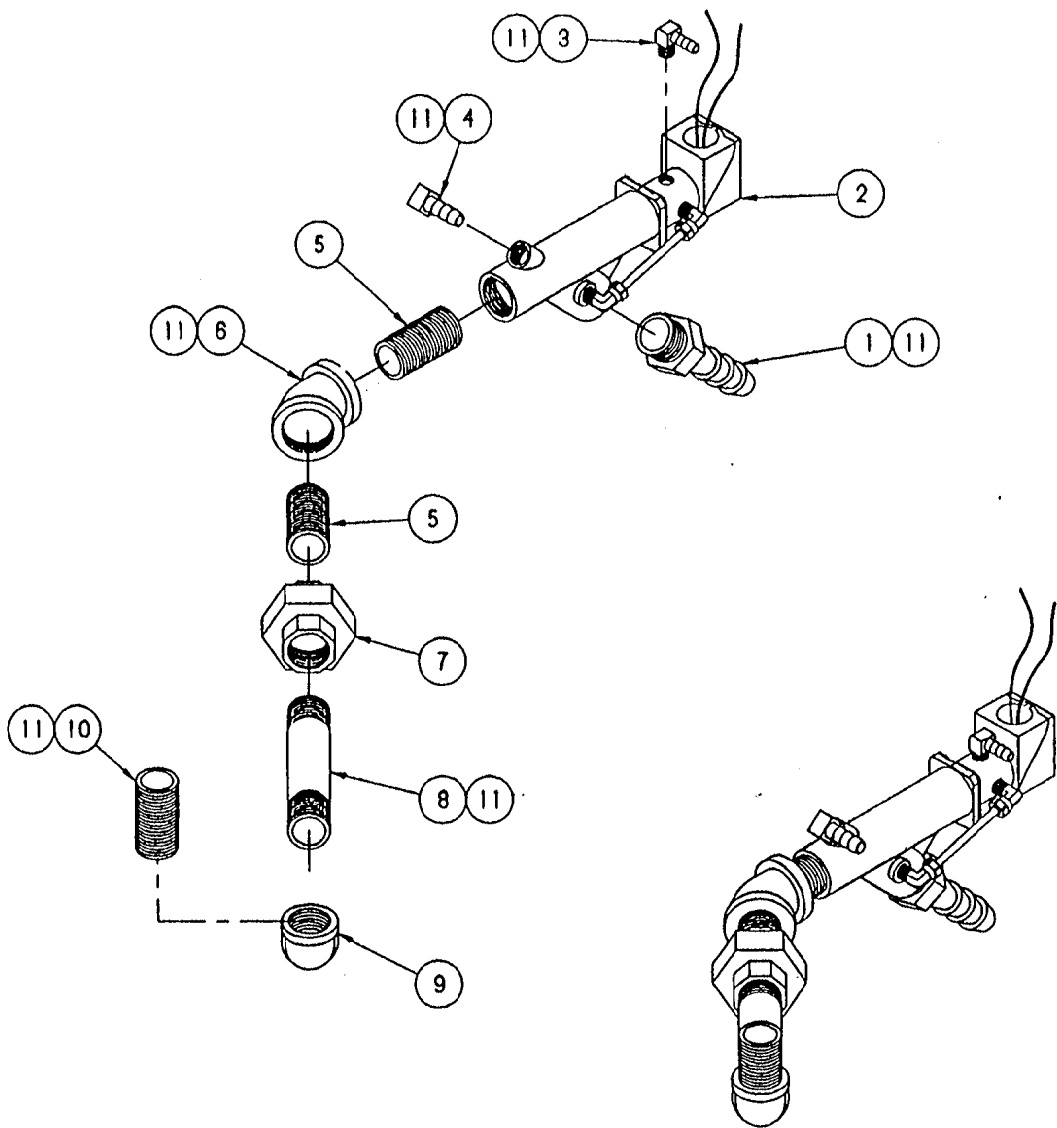

LET.	REVISIONS	DATE	BY
A	REDRAWN - P/N 06210 WAS 06208, P/N 06211 WAS 06207, E.O. C-1994	08-15-91	PJD
B	P/N 20208 WAS 20249 ADDED P/N 14490 & P/N 00934 E.O. 4C-2075	11-12-91	PJD
C	ROTATED THREAD POSITION ON P/N'S 05283 & 03277, MOVED P/N 14342. E.O. 4C-2350	1-12-93	NLT
D	P/N 06240 WAS 06241, P/N 22244 WAS 22221, P/N 105786 WAS 06214, P/N 14342 WAS 14324, P/N 05280 WAS 20206, P/N 105787 ADDED AND P/N'S 02586, 05283 & 03277 OMITTED PER E.O. 4C-2448	08-21-93	PJD

11	A/N	00934	SEALANT, RECTORSAL
10	I	14490	HIPPLE, 3/4 X CLOSE, 8/8
9	I	05280	ELBOW, 1/2 NPT X 90°, BRASS
8	I	14355	HIPPLE, 3/4 NPT X 5' LG., BRASS
7	I	21304	UNION, 3/4 NPT, BRASS
6	I	05282	ELBOW, 3/4 X 45°, BRASS
5	2	14342	HIPPLE, 3/4 X CLOSE, BRASS
4	I	105788	FITTING, HOSE BARB, 1/4 H X 1/4 NPT, 90°
3	I	105787	FITTING, HOSE BARB, 1/4 H X 1/8 NPT, 90°
2	I	22244	VALVE, SOLENOID, 1/2", 15 PSI
1	I	06240	FITTING, HOSE BARB, 3/4 H X 3/4 NPT

NO.	QTY.	PART NO.	DESCRIPTION
TOLERANCES <small>UNLESS OTHERWISE SPECIFIED</small> DECIMAL ± N/A ANGULAR ± N/A			
CLEVELAND RANGE INC. 1330 East 179th St., Cleveland, Ohio 44110-2574			
SCALE	1/2	DRAWN BY	J.J.
TITLE		APPROVED BY	
PIPING ASSEMBLY, DRAIN			
24CSM, 36CSM, 42CSM, PSM			
DATE	11-21-84	DRAWING NO.	C-42813
REV.	D		

THIS DESIGN DESCRIBES A PROPRIETARY ITEM AND IS THE PROPERTY OF CLEVELAND RANGE. THIS DRAWING IS NOT TO BE COPIED OR USED WITHOUT THE APPROVAL OF CLEVELAND RANGE.

LET	REVISIONS	DATE	BY
-	PRODUCTION RELEASE E.O. #C-2008	09-10-91	PJD
A	P/N 05259 WAS QTY. OF 2 E.O. #C-2048	10-11-91	PJD
B	P/N 105541 WAS P/N 20249 E.O. #C-2134 RI	03-11-92	PJD
C	P/N 05259 WAS QTY. OF 3, P/N 105541 OMITTED, P/N 08240 WAS QTY. OF 3 PER E.O. #C-2448	07-21-93	PJD

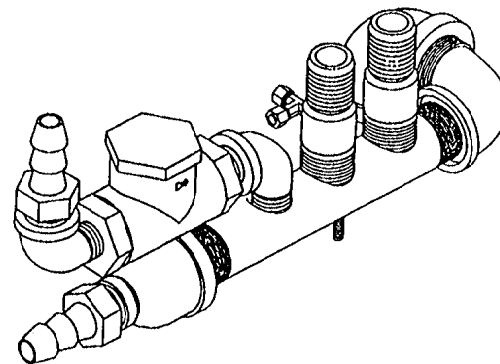
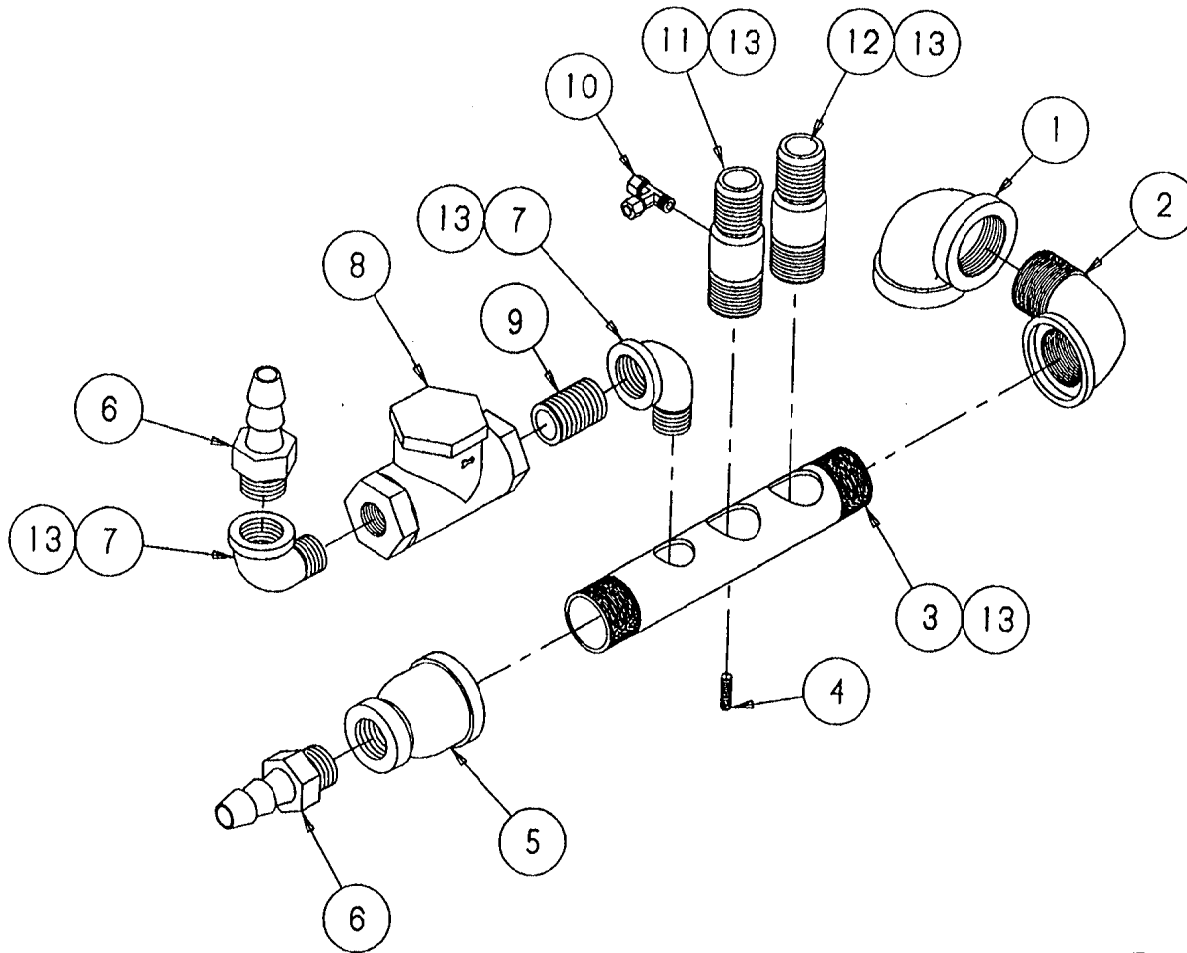

ASSEMBLED UNIT

NO.	QTY.	PART NO.	DESCRIPTION
13	A/A	00934	SEALANT, RECTORSEAL
12	1	14481	FITTING, BARB 1" HOSE X 1" MPT S/S
11	1	585191	FITTING, HOSE - DRAIN MANIFOLD WITH 1/8" HOLE
10	1	101394	TEE, MALE RUN 1/4" T X 1/4" T X 1/8"
9	1	14343	HIPPLE, CLOSE, 3/4", BLACK
8	1	22119	VALVE, SWING CHECK, 3/4"
7	2	05259	ELBOW, STREET, 90°, 3/4", BLACK
6	2	08240	FITTING, HOSE BARB 3/4" HOSE X 3/4" MPT
5	1	03818	COUPLING, RED, 1-1/2 - 3/4" BLACK
4	1	19917	STUD, WELD, 1/4-20 X .075 S/S
3	1	13252	MANIFOLD, DRAIN 1-1/2 NPT BLACK
2	1	05292	ELBOW, STREET 1-1/2 NPT X 90° BLACK
1	1	05238	ELBOW, 1-1/2 NPT X 90° BLACK

TOLERANCES (UNLESS AS NOTED)			
DECIMAL	SCALE	DRAWN BY	APPROVED BY
± N/A	1/2"	P.J.D.	D.S.
ANGULAR	TITLE	DATE	
± N/A	DRAIN, MANIFOLD ASSEMBLY 42CKGM/SM 42CKGM/LG. M, 42CKSM	09-10-91	
CK	DRAWING NO.	REV.	C
	C-104873		

THIS DESIGN DESCRIBES A PROPRIETARY ITEM AND IS THE PROPERTY OF CLEVELAND RANGE. THIS DRAWING IS NOT TO BE COPIED OR USED WITHOUT THE APPROVAL OF CLEVELAND RANGE.

CLEVELAND RANGE INC.

1333 East 179th St. Cleveland, Ohio 44110-2574

