



Visit www.clevelandrange.com to locate a service or sales representative in your area.



Modular Boiler Bases/ KETTLES on Boiler Bases (Gas, Electric, Direct Connect & Steam Coil Models)

Installation, Operation & Maintenance Manual

This manual is updated as new information and models are released. Visit our website for the latest manual.

For your future reference.

Model # _____

Serial # _____



***Read the manual thoroughly.
Improper installation, operation or
maintenance can cause property
damage, injury or death.***



STATEMENT OF RESPONSIBILITIES / DÉCLARATION DES RESPONSABILITÉS / DECLARACIÓN DE RESPONSABILIDADES

This document is for use by experienced and trained Qualified Cleveland Range, LLC Authorized Service Representatives who are familiar with both the safety procedures, and equipment they service. Cleveland Range, LLC assumes no liability for any death, injury, equipment damage, or property damage resulting from use of, improper use of, or failure to use the information contained in this document. Cleveland Range, LLC has made every effort to provide accurate information in this document, but cannot guarantee that this document does not contain unintentional errors and omissions.

The information in this document may be subject to technical and technological changes, revisions, or updates. Cleveland Range, LLC assumes no liability or responsibility regarding errata, changes, revisions, or updates.

Qualified Cleveland Range, LLC Authorized Service Representatives are obligated to follow industry standard safety procedures, including, but not limited to, OSHA regulations, and disconnect / lock out / tag out procedures for all utilities including steam, and disconnect / lock out / tag out procedures for gas, electric, and steam powered equipment and / or appliances.

All utilities (gas, electric, water and steam) should be turned OFF to the equipment and locked out of operation according to OSHA approved practices during any servicing of Cleveland Range equipment

Qualified Cleveland Range, LLC Authorized Service Representatives are obligated to maintain up-to-date knowledge, skills, materials and equipment.

Ce document est destiné à l'usage des Représentants de Service qualifiés et autorisés de Cleveland Range, LLC qui possèdent l'expérience et la formation ainsi que la bonne connaissance des mesures de sécurité et du matériel qu'ils entretiennent.

Cleveland Range, LLC décline toute responsabilité pour tout cas de décès, blessure, dommage matériel ou dommage aux biens résultant de l'utilisation, de la mauvaise utilisation ou du manquement d'utilisation des renseignements contenus dans ce document.

Cleveland Range, LLC s'est efforcé à fournir des renseignements précis dans ce document mais ne peut garantir que ce document soit exempt d'erreurs et d'omissions non intentionnelles.

Les renseignements contenus dans ce document peuvent être assujettis à des changements techniques et technologiques, des révisions ou des mises à jour.

Cleveland Range, LLC décline toute obligation ou responsabilité concernant les errata, modifications, révisions ou mises à jour.

Les Représentants de Service qualifiés et autorisés de Cleveland Range, LLC sont tenus de se conformer aux mesures de sécurité normalisées de l'industrie, y compris, mais sans s'y limiter, les réglementations de l'OSHA, les procédures de débranchement / verrouillage / étiquetage relatives à tous les services publics, dont l'approvisionnement en vapeur, et les procédures de débranchement / verrouillage / étiquetage relatives aux équipements et/ou appareils fonctionnant au gaz, à l'électricité et à la vapeur.

Au cours de tout entretien d'un appareil Cleveland Range, tous les services publics (gaz, électricité, eau et vapeur) doivent être FERMÉS au niveau de l'appareil et le dispositif de fonctionnement doit être verrouillé suivant les pratiques approuvées de l'OSHA.

Les Représentants de Service qualifiés et autorisés de Cleveland Range, LLC sont tenus d'actualiser en permanence leurs connaissances, compétences, matériel et équipement.

Este documento está destinado para el uso de los Representantes de Servicio calificados y autorizados de Cleveland Range, LLC quienes cuentan con la experiencia y la capacitación así como el buen conocimiento de las medidas de seguridad y de los equipos que mantienen.

Cleveland Range, LLC, declina toda responsabilidad en caso de cualquier fallecimiento, lesiones, daños al equipo o daños a la propiedad resultantes de la utilización, del uso indebido o de la falta de utilización de la información provista en este documento.

Cleveland Range, LLC se ha esforzado en suministrar información precisa en este documento, pero no puede garantizar que este documento esté exento de errores y de omisiones no intencionales.

La información contenida en este documento podría estar sujeta a cambios técnicos o tecnológicos, revisiones o actualizaciones. Cleveland Range, LLC declina toda obligación o responsabilidad con respecto a erratas, modificaciones, revisiones o actualizaciones.

Los Representantes de Servicio calificados y autorizados de Cleveland Range, LLC tienen la obligación de seguir los procedimientos estándar de seguridad de la industria; los cuales incluyen pero no se limitan a los reglamentos de la OSHA (La Administración de la Seguridad y Salud Ocupacionales), los procedimientos de desconexión, cierre y etiquetado relativos a todos los servicios públicos incluyendo el suministro de vapor y los procedimientos de desconexión, cierre y etiquetado para los equipos y/o aparatos que funcionan a base de gas, electricidad o vapor.

Cuando se esté dando servicio o mantenimiento a un aparato de Cleveland Range, todos los servicios públicos (gas, electricidad, agua y vapor) deben estar APAGADOS para el equipo en cuestión y se debe seguir el procedimiento de cierre de operaciones de acuerdo con las prácticas aprobadas por la OSHA.

Los Representantes de Servicio calificados y autorizados de Cleveland Range, LLC tienen la obligación de actualizar constantemente sus conocimientos, destrezas, materiales y equipamiento.

FOR YOUR SAFETY / POUR VOTRE SÉCURITÉ / PARA SU SEGURIDAD

FOR YOUR SAFETY

Do not store or use gasoline or any other flammable liquids and vapours in the vicinity of this or any other appliance.

POUR VOTRE SÉCURITÉ

Ne pas entreposer ou utiliser d'essence ou d'autres liquides ou vapeurs inflammables à proximité de cet appareil ou de tout autre appareil.

PARA SU SEGURIDAD

No guarde ni use gasolina o cualesquiera otros líquidos o vapores inflamables en las cercanías de éste o cualquier otro aparato.

WARNING: Improper installation, operation, adjustment, alteration, service or maintenance can cause property damage, injury or death. Read the installation and operating instructions thoroughly before installing, operating or servicing this equipment.

AVERTISSEMENT : Toute mauvaise pratique en matière d'installation, de fonctionnement, de réglage, de modification, d'entretien ou de maintenance peut causer des dommages matériels, des blessures ou la mort. Lisez la totalité des instructions d'installation et d'utilisation avant d'installer, d'utiliser ou d'entretenir cet équipement.

ADVERTENCIA: La indebida instalación, operación, ajuste, modificación, servicio o mantenimiento puede ocasionar daños a la propiedad, lesiones o muerte. Lea detenidamente las instrucciones de instalación y de operación antes de instalar, poner a funcionar o dar servicio a este equipo.

Do not spray aerosols in the vicinity of this appliance while it is in operation.

This appliance is not to be used by persons with reduced physical, sensory or mental capabilities, or lack of experience and knowledge, unless they have been given supervision or instruction concerning use of the appliance by a person responsible for their safety.

This appliance is not for use by children and they must be supervised not to play with it.

Retain this manual for your reference. The boiler base Tabletop is NOT a supporting surface. Death, Injury or Equipment Damage will result from mounting or placing anything on the Tabletop.

When the ON/OFF lever is turned to the OFF position, Steamer will remain HOT for some time. Avoid contact with hot surfaces and steam.

Death, Injury or Equipment Damage can result from touching any component inside this appliance when the power is connected.

Ne pas pulvériser des aérosols dans le voisinage de cet appareil alors qu'il est en fonctionnement.

Cet appareil ne doit pas être utilisé par des personnes dont les capacités physiques, sensorielles ou mentales sont réduites, ou des personnes dénuées d'expérience ou de connaissance, sauf si elles ont pu bénéficier, par l'intermédiaire d'une personne responsable de leur sécurité, d'une surveillance ou d'instructions préalables concernant l'utilisation de l'appareil.

Cet appareil n'est pas destiné à être utilisé par des enfants et ils doivent être surveillés pour s'assurer qu'ils ne jouent pas avec l'appareil.

Conservez ce manuel pour votre référence.

No pulverice aerosoles en las proximidades de este aparato mientras está en funcionamiento.

Este aparato no debe ser utilizado por personas con capacidades físicas, sensoriales o mentales reducidas, o que no tengan la experiencia y los conocimientos adecuados, a menos que estas personas hayan recibido supervisión e instrucciones en cuanto al uso del aparato por la persona responsable de la seguridad de ellas.

Guarde este manual para su referencia.



WARNING / AVERTISSEMENT / ADVERTENCIA



Improper installation, operation, adjustment, alteration, service or maintenance can cause property damage, injury or death. Read the installation and operating instructions thoroughly before installing, operating or servicing this equipment. / Toute mauvaise pratique en matière d'installation, de fonctionnement, de réglage, de

modification, d'entretien ou de maintenance peut causer des dommages matériels, des blessures ou la mort. Lisez la totalité des instructions d'installation et d'utilisation avant d'installer, d'utiliser ou d'entretenir cet équipement. / La indebida instalación, operación, ajuste, modificación, servicio o mantenimiento puede ocasionar daños a la propiedad, lesiones o muerte. Lea detenidamente las instrucciones de instalación y de operación antes de instalar, poner a funcionar o dar servicio a este equipo.



Do not lean on or place objects on the equipment. / Ne vous penchez pas sur ou ne placez pas des objets sur la lèvre. / No se apoye ni coloque objetos en el labio.



Hot product and surfaces. / Produit et surfaces chaudes. / Producto y superficies calientes.

Do not touch. / Ne pas toucher. / No la toque



Stand clear of product discharge path when discharging hot product. / Écartez-vous du chemin de décharge d'un produit chaud. / Permanezca alejado de la ruta de descarga del producto al vaciar producto caliente.



Keep hands away from moving parts and pinch points. / Gardez les mains loin des pièces mobiles et des points de pincement. / Mantenga las manos lejos de piezas móviles y puntos de presión muy localizada.



Inspect unit daily for proper operation. / Inspectez l'unité tous les jours pour son bon fonctionnement. / Inspeccione diariamente el funcionamiento correcto de la unidad.



Pressurized device. / Appareil sous pression. / Dispositivo de presión.

Keep clear of pressure relief discharge. / Restez à l'écart de la soupape de sûreté. / Permanezca alejado de la descarga de presión.



Do not climb, sit or stand on equipment. / Il ne faut pas monter, s'asseoir ni se tenir debout sur l'équipement. / No subirse, ni sentarse ni pararse sobre el equipo.



Surfaces and product may be hot! Wear protective equipment. / Les surfaces et le produit peuvent être chauds! Portez un équipement de protection. / ¡Las superficies y el producto pueden estar calientes! Utilice equipo protector.



Heavy / Lourd / Pesado

Team or mechanical lift. / Équipe ou remontée mécanique. / Equipo o elevador mecánico.



Floor may become slippery from product spillage. / Déversement de produit peut causer de plancher à être glissant. / Derrame de producto puede causar piso a ser resbaladizo.



Unit must be anchored as per manual. / Unité doit être ancrée selon les directives du manuel. / Unidad debe estar fijado según el manual.



Do not fill kettle above recommended level marked on outside of kettle. / Ne remplissez pas la chaudière en excès du niveau recommandé marqué sur la chaudière. / No llene la marmita arriba del nivel recomendado marcado fuera de la marmita.

SERVICING / ENTRETIEN / SERVICIO



Have a qualified service technician maintain your equipment. / Demandez à un technicien en entretien et en réparation qualifié d'effectuer l'entretien de votre équipement. / Haga que un técnico de servicio calificado mantenga su equipo



Ensure kettle is at room temperature and pressure gauge is showing zero or less prior to removing any fittings. / Assurez-vous que la chaudière est à température ambiante et que le manomètre est à zéro ou moins avant de retirer des accessoires. / Asegúrese de que la marmita esté a temperatura ambiente y el manómetro esté mostrando cero o menos antes de retirar cualquier accesorio.



Remove electrical power prior to servicing. / Coupez l'alimentation électrique avant l'entretien. / Desconecte la energía eléctrica antes de darle servicio.

Risk of electric shock. / Risque de choc électrique. / Riesgo de choque eléctrico.

Table of Contents

Section 1

General Installation Information (Boiler Bases)

Product Information	1
Product Information Plate.....	1
Electrical Diagram Location.....	1
Optional Equipment	1
Modular Interconnect Kit (IMK) P/N 409351, 409355, 409358, 4093513	1
Laws, Codes, and Regulations	2
Operational Safety	2
Inspect for Shipping Damage	3
Dimensions	3

Section 2

Installation

Select a Location	4
Exhaust Hood Requirements	5
Position and Level the Appliance	5
Gas Supply (for gas units)	5
Gas Supply Requirements	5
Gas Supply Line Requirements	6
Test Gas Supply Lines.....	6
Pressure Test Gas Supply Lines.....	6
Water Supply	7
Water Supply Quality Requirements	7
Connect the Water Supply Lines.....	7
Installation Requirements	7
Test Water Supply Lines	7
Electric Power Supply	8
Free Air Vented Drain Line	8
Drainpipe Size and Length Guidelines	9
Connection.....	9
Direct Connect Steamer/Kettle Connections	9
Steam Coil Steam Generator Connections	9
Gauge Pressure Readings	10
Installation Checklist	11
Steam Generator Controls	12

Section 3

Start-Up Procedure — Gas Fired Units

Burner Ignition Test (Lighting and Shutdown Instructions)	14
Lighting Instructions (Test of function of pilot light and burner ignition system) for Gas	14
ShutdownInstructions	15

Table of Contents (continued)

Section 4

Start-Up Procedure — Electric Units

Start-Up (Start-Up and Shutdown Instructions)..... 16
Start-Up Instructions..... 16
Shutdown Instructions.....16

Section 5

Operating Tests

Start-Up Test Procedure for the Boiler Bases, Gas-Fired and Electric 18
Start-Up Procedure with the Appliance De-Energized..... 18
Boiler Drain and Rinse Cycle Inspection (3-Minute Blowdown Cycle)18
Operating Test Procedures..... 19

Section 6

General Information (KETTLES on Boiler Bases).....20

Section 7

Maintenance (KETTLE & Steam Generator)

Maintenance & Service Records.....21
Clean after Cooking.....21
Steam Generator Maintenance procedure.....22
Descaling (Steam Generator).....22

Section 8

Troubleshooting

Troubleshooting Guide (KETTLE).....23
Troubleshooting Guide (BOILER BASE)24
Water Level Control System Troubleshooting..... 26

Section 1

General Installation Information

For Boiler Bases

Product Information

This manual covers the installation of Cleveland Range Gas-Fired, Electric, Direct Connect, Steam Coil Steam Boiler Bases and Kettles on boiler bases and covers the standard features and options available on these models.

- Other than selection of options, there are presently no significant design, parts, or operating differences among appliances with these models.
- Instructions for equipment attached to boiler bases are separate.
- Dimension figures illustrate the dimensions, clearances, and major external features of steam boiler bases.

PRODUCT INFORMATION PLATE

The Product Information Plate inside the cabinet door of the appliance lists:

- Model
- Serial Number
- Clearances
- Power and Wiring Requirements
- Fuel Gas Type and Requirements (gas units only)
- BTU/HR (gas units only)

ELECTRICAL DIAGRAM LOCATION

The Electrical Diagram is located on the inside of the cabinet door.

DANGER

The boiler base Tabletop is NOT a supporting surface. Death, Injury or Equipment Damage will result from mounting or placing anything on the Tabletop.

Optional Equipment

MODULAR INTERCONNECT KIT (IMK) P/N 409351, 409355, 409358, 4093513

DANGER

Improper installation, adjustment, alteration, service, or maintenance of a Power Take-Off Kit or Modular Interconnect Kit, or installation of a Power Take-Off Kit or Modular Interconnect Kit damaged during shipment or storage can cause DEATH, INJURY, AND EQUIPMENT DAMAGE. Also, any of these conditions may void the Warranty.

Power Take-Off and Modular Interconnect Kits are designed for installation by a qualified Cleveland Range authorized service representative. These kits must be installed according to the policies and procedures outlined in this manual and supplemental instructions.

- These kits are intended for use when interconnecting Cleveland Range products only.
- Misuse of these kits, or parts therein, can result in personal injury, product or property damage, and voiding of product warranties.
- Installation must be made by a qualified Cleveland Range authorized Service Representative.

The Modular Interconnect Kit (IMK) attaches to the PTO and connects the Boiler to a direct connect steam powered appliance. A direct connect steam powered appliance is one that has no Boiler or other steam generator and uses steam piped in from another source to operate. The IMK cannot be used to connect steam sources together.

See Installation Instructions P/N 260ALF and P/N 260WS for details.

DANGER

Pressurized Steam Hazard

Do not connect multiple steam sources together with the Modular Interconnect kit or by any other method. Death, injury, or equipment damage can result.

Laws, Codes, and Regulations

This equipment should be installed only by qualified, professional plumbers, pipe fitters, and electricians.

The installation of this appliance must conform with:

- A. The National Fuel Gas Code, ANSI Z223.1/NFPA 54 (latest edition), or the Natural Gas and Propane Installation Code CSA B149.1, or local codes, as applicable.
- B. The National Electrical Code, ANSI/NFPA 70 (latest edition), or the Canadian Electrical Code, CSA C22.2, or local codes, as applicable.
 - When installed, the appliance must be electrically grounded in accordance with the above.
 - NOTE: This appliance is not GFI (GFCI) compatible.
- C. The Food Code (latest edition) of the Food and Drug Administration (FDA).

This equipment is to be installed to comply with the applicable federal, state, or local plumbing codes.

This appliance is equipped with a Boiler as defined by Section IV of the ASME Boiler and Pressure Vessel Code (latest edition). In addition to compliance with all applicable codes and regulations, compliance with all laws regarding Boilers and Pressure Vessels, including, but not limited to, operator training, and obtaining permits and licenses is required before starting the Boiler.

Installation instructions must be read in their entirety before starting installation of this appliance.

Install this appliance according to the policies and procedures outlined in this manual.

Installation must comply with all local fire and health codes.

DANGER

Improper installation, adjustment, alteration, service, or maintenance of this appliance, or installation of a damaged appliance can result in DEATH, INJURY, EQUIPMENT DAMAGE, and void the warranty.

NEVER install damaged appliances, equipment, or accessories.

ALWAYS have installation and service performed by qualified Cleveland Range authorized personnel.

Operational Safety

The safe and effective operation of any steamer depends upon proper installation, use, maintenance, and repair. Operational safety must encompass all of these factors. This Operational Safety section outlines the minimum safety policies that should be considered when using one or more Gemini steamers. It is assumed that any operational safety program must be tailored to the specific site and use of the equipment.

Burn hazards are present in any professional food service operation. When using the steamer, observe the following precautions.

Operational Safety

The Operational Safety section outlines minimum safety policies and procedures for operating one or more Cleveland Range appliances.

1. Do not store anything on top and underneath the appliance.
2. KEEP THE APPLIANCE AREA FREE AND CLEAR OF COMBUSTIBLES.
3. Proper air supply for ventilation and combustion is REQUIRED for and CRITICAL to safe, efficient operation of this appliance.
4. Place non-slip draining anti-fatigue mats rated for use in wet, greasy, or dry work areas on the floor in front of the appliance and other locations as needed. Obtain the best mats for your needs from your local supplier.
5. Wear BOOTS appropriate to the work area to help protect feet, and to help prevent slips and falls.
6. Allow only qualified Cleveland Range authorized service representatives to service the appliance.
7. Use only factory authorized repair parts.
 - a. Maintain written records of appliance service, maintenance, and repair. See Chapter 6.

Inspect for Shipping Damage

If the appliance is damaged or damage is suspected:

1. Submit a Damage Claim to the Shipper immediately.
2. Inform your dealer at once.
3. Inform Cleveland Range in writing within three (3) days.

DANGER

Operating this appliance out of level can cause DEATH, INJURY, and EQUIPMENT DAMAGE.

This appliance must be level both front-to-back and side-to-side in all installations.

NEVER operate this appliance out of level.

If this appliance is suspected to be out of level, shut it down at once and call your qualified Cleveland Range authorized service agency immediately.

Dimensions

For information on dimensions for below models, please refer to their respective Spec sheets.

- 24-GM, 36-GM GAS-FIRED BOILER BASES,
- 24-EM, 36-EM ELECTRIC BOILER BASES,
- 42-GM GAS-FIRED BOILER BASES,
- 42-EM ELECTRIC BOILER BASES,
- CONVECTIONPRO STEAMER (eg 36-CGM-16-300),
- CLASSIC CONVECTION STEAMER WITH KETTLE (eg 42-CKGM-300)

Section 2 Installation

DANGER

High Heat Hazard

Do NOT run utility lines under the Steam Boiler Base. Heat or water from the Boiler and heat from the burners or heaters can damage utility lines and cause DEATH, INJURY, and EQUIPMENT DAMAGE.

Gas-Fired boilers are only to be installed in non-combustible areas that have provisions for adequate air supply.

Select a Location

For safe and efficient operation:

- Installation must comply with all local fire and health codes.
- A 6" (six inch) clearance must be maintained at the sides and rear of the appliance. **This appliance must be installed only in a non-combustible location.** See Dimensions.
- The location selected must be capable of supporting this appliance. The operating weight of a 24-GM-200 is 650 lbs, and a 36-GM-300 is 786 lbs.
- Position the appliance so it will not tip or slide.
- The operating surface must be level enough to allow leveling with the adjustable legs. This appliance **MUST** be level both front-to-back and side-to-side before operation.
- A suitable drain must be available within 12 feet of this appliance. Do NOT install the appliance directly over a drain.
- The location must include space for Operating and Service/Secondary Clearances and the Exhaust Hood. See Dimensions.
- The flooring that will be directly under the boiler must also be made of a non-combustible material.

Warning

This appliance must be installed only in a non-combustible location.

All clearance requirements above, below, and around this appliance are for non-combustible locations only.

Installation in a combustible location or failure to maintain required clearances and additional distances as needed can result in INJURY and EQUIPMENT DAMAGE.

Consult manufacturers' literature, and sales and service agencies as needed.

- KEEP THE APPLIANCE AREA FREE AND CLEAR OF COMBUSTIBLES.
- Proper air supply for ventilation and combustion is REQUIRED for and CRITICAL to safe, efficient operation of this appliance.
- Make sure the air vents of this appliance are not blocked with or by anything.
- Allow for sufficient extra distance if a high heat source, e.g. a broiler, is located next to this appliance. Contact Cleveland Range at 216-481-4900 or 1-800-338-2204 for recommendations.
- Do NOT install this appliance directly over a drain. Steam rising up out of the drain will adversely affect operation, hamper cooling air circulation, and damage electrical and electronic components.

Exhaust Hood Requirements

Gas-fired appliances must be installed under a suitable ventilation hood as required by the National Fuel Gas Code, ANSI Z223.1/NFPA 54 and ANSI Z83.11-2004 / CSA 1.8-2004.

Local code may require electric, direct connect, or steam coil appliances to be installed under a suitable ventilation hood.

The ventilation hood system must include an interlock to prevent the operation of this appliance without the operation of the ventilation hood.

The exhaust hood must extend over the gas flue opening and meet the following requirements:

- A. This gas-fired appliance must be vented in accordance with all local, state and national codes for venting gas-fired appliances.
- B. The exhaust hood must be sized for the cumulative ventilation requirements of all the gas-fired appliances in the area under the hood, including this appliance.
 - The BTU/HR for a 24-GM-200 is 200,000 BTU/HR.
 - The BTU/HR for a 36-GM-300 is 300,000 BTU/HR.
 - Call Cleveland Range for BTU/HR of other gas boiler bases.
- C. If an existing hood does not meet all specifications, a new one must be constructed.
- D. When determining hood size, include operating clearances. See Dimensions.

Position and Level the Appliance

1. Move the appliance into position.
2. Place a level along the bottom edge of the appliance.
3. Use the adjustable legs of the appliance to level it front-to-back and side-to-side.

DANGER

High Heat Hazard

Do NOT run utility lines under the Steam Boiler Base. Heat or water from the Boiler and heat from the burners or heaters can damage utility lines and cause DEATH, INJURY, and EQUIPMENT DAMAGE.

Gas Supply (for gas units)

Important

- Post instructions to be followed if the user smells gas.
- Display the instructions in a prominent location.
- Obtain the instructions from the local gas supplier.

GAS SUPPLY REQUIREMENTS

- Gas supply type MUST match the type of gas shown on the rating plate.
- Gas supply pressure must NOT exceed 14" water column.
- Gas supply pressure must be within the pressure range shown below when using 1" NPT gas line and a 3/4" NPT connection.
 - Natural gas pressure at 1000 BTU/CF must be 5-1/2" – 14" water column.
 - Propane gas pressure must be between 11" – 14" water column.
- If the gas or propane supply pressure exceeds 14" water column, a pressure regulating valve (pressure regulator) must be installed in the gas supply line to reduce pressure to this appliance. See the Gas Supply Line Layout figure.

GAS SUPPLY LINE REQUIREMENTS

The Installer/Owner is responsible for furnishing and installing gas supply lines, valves, regulators, and accessories.

When installing gas supply lines and accessories, observe the following:

- Refer to the Gas Supply Line Layout figure for the recommended layout of the gas supply lines.
- Use non-hardening pipe thread sealant resistant to LP gas.
- The 3/4" NPT gas inlet is on the bottom of the appliance.
- Install main manual shutoff valve between the gas supply and the appliance. See figure. This main manual shutoff valve is called the Main Manual Gas Valve.
- Install a sediment trap (drip leg) in gas supply line. See figure.

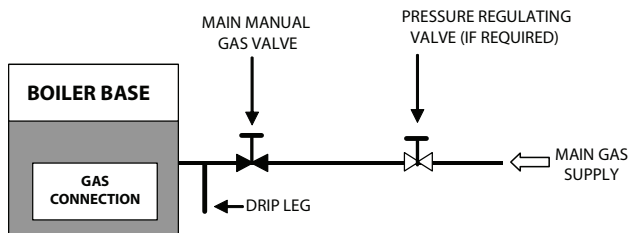

Gas Supply Line Layout

TEST GAS SUPPLY LINES

1. Check all connections for proper tightness.
2. Remove the control side panel to inspect internal gas connections. Do not replace the panel until installation is complete.
3. Open the gas supply valves.
4. Check all lines and connections for leaks, both inside and outside this appliance, with soap and water solution.
5. All leaks must be corrected before attempting to operate this appliance.

PRESSURE TEST GAS SUPPLY LINES

If pressure testing is required, this appliance must be disconnected or isolated from the gas supply piping system during pressure testing as follows:

- The appliance and its individual shutoff valve (Main Manual Gas Valve) must be **disconnected** from the gas supply piping system during any pressure testing of that system at test pressures in excess of 1/2 psi (14" water column or 3.45 kPa).
- The appliance must be **isolated** from the gas supply piping system by closing its individual manual shutoff valve (Main Manual Gas Valve) during any pressure testing of the gas supply piping system at test pressures equal to or less than 1/2 psi (14" water column or 3.45 kPa).

Water Supply

WATER SUPPLY QUALITY REQUIREMENTS

Important

The use of good quality feed water as listed in the Cleveland Range Limited Warranty is the responsibility of the Owner-User.

See Water Quality Recommendations as listed in the Cleveland Range Limited Warranty.

THE USE OF POOR QUALITY FEED WATER WILL VOID EQUIPMENT WARRANTIES.

- Contact Cleveland Range for details on how to provide water per Minimum Water Quality Requirements in the Warranty, or how to increase the frequency of maintenance, cleaning, and descaling.
- Poor water supply quality degrades performance.
- Check the quality of supply water before designing the water supply by contacting a local water treatment specialist for on-premises water analysis.
- Softened or chlorinated water damages the boiler by increasing corrosion. Carbon type filters are required before water enters the boiler if supply water is softened or chlorinated.
- If a water treatment system must be installed to achieve acceptable water quality, install it BEFORE connecting the water supply lines.
- If analysis shows that supply water is below Minimum Water Quality:
 - **EITHER:** A water treatment system and/or carbon filter must be installed in the line feeding the Boiler.
 - **OR:** The frequency of maintenance, cleaning, and descaling must be increased beyond that recommended in the maintenance schedule. See the Maintenance section of the Installation, Operation and Maintenance Manual.

Note: if equipped with a Kettle and Kettle water fill swing spout, 3/8" hot and/or cold water connections will be required at the swing spout's valve. A kettle fill faucet, if so equipped, requires a hot and/or cold water connection

CONNECT THE WATER SUPPLY LINES

The Installer/Owner is responsible for the water connection of this appliance.

This appliance is to be installed to comply with all applicable federal, state, or local plumbing codes.

Connect this appliance to COLD WATER. The condenser system and boiler will not work properly if they are connected to HOT or WARM water.

See the Cleveland Range Water Supply Arrangement figure.

Important

Water supply must have a minimum dynamic (flow) pressure of 35 psi (2.4 kg/cm²) and a maximum static pressure of 60-psi (4.1 kg/cm²).

If the static pressure is above 60 psi, a pressure regulator must be used and set at approximately 50 psi. Pressure above 60 psi can damage solenoid valves.

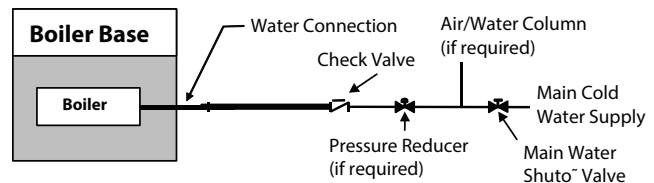

Cleveland Range Water Supply Arrangement

INSTALLATION REQUIREMENTS

- Apply non-hardening pipe thread sealant to threaded connections.
- The Boiler Base has a 1/4" NPT female fittings on its underside for the Boiler. See Dimensions.
- Install a manual water shutoff valve (Main Water Shutoff Valve) (not provided) between the cold water supply line(s) and the appliance.
- The National Sanitation Foundation (NSF) requires installation of a check valve (or other approved anti-backflow/anti-siphon device) (not provided) in all supply lines in accordance with and as required by local, state, and national health, sanitation and plumbing codes.
- A 40 mesh water strainer (dirt filter), Cleveland Range Part Number 19870, is factory installed.
- Flush the water supply lines before connecting the lines to the appliance.

TEST WATER SUPPLY LINES

1. Check all connections for proper tightness.
2. Remove the side panels to inspect the water connections inside the appliance.
3. Open the water supply valves.
4. Check all lines and connections for leaks, both inside and outside the appliance.

Electric Power Supply

The electric supply must match all electrical and wiring requirements specified on the rating plate.

NOTE: This appliance is NOT Ground Fault Interrupter (GFI or GFCI) compatible.

NOTE: The Electrical Diagram is located on the inside of the cabinet door.

The connection must be made as follows:

1. Install a main disconnect switch and a separate fuse or breaker for this appliance as shown in the Electrical Layout figure. The fused disconnect switch is referred to as the Main External Power Switch.
2. Do not use a GFI (GFCI) circuit. This appliance is not GFI compatible.
3. **Do NOT use a power cord.**
4. Make the electrical connection using flexible conduit, per local code. See the Hardwire Connection figure.

⚠ Warning

This appliance is not GFI (GFCI) compatible.

Do not use a GFI (GFCI) circuit.

Using a GFI (GFCI) circuit can result in injury, equipment damage, and property damage.

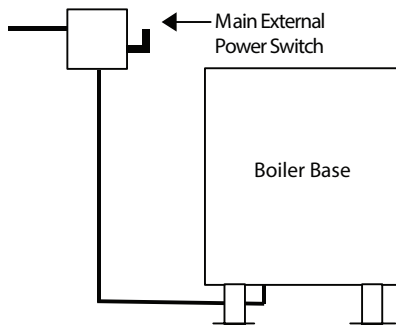

Electrical Layout

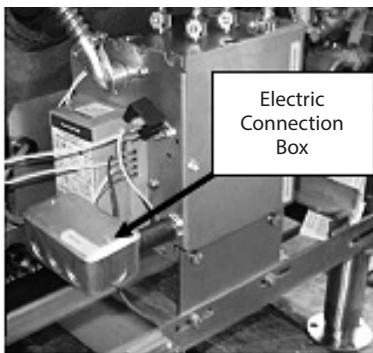

Hardwire Connection

Free Air Vented Drain Line

DANGER

DEATH, INJURY, EQUIPMENT and PROPERTY DAMAGE will result from improper installation of drain outlet lines. Install free air vented drain lines as described in this manual.

Important

Furnishing and installing drain lines and drainpipe is the responsibility of the Installer/Owner.

The following restrictions and requirements are critical to the safety of personnel and equipment, and must not be violated under any circumstances:

- The drain lines must be installed in compliance with the Food Code (latest edition) of the Food and Drug Administration (FDA), and any other applicable national, state, or local codes and regulations.
- The drain line must be free air vented, have gravity flow from the appliance, and terminate outside the perimeter of the appliance.
- Free air venting requires a minimum 1" clearance between the end of the drain line and the top of the floor drain. See the Typical Drain Layout figure.
- Do NOT install the appliance directly over a drain. Steam rising up out of the drain will adversely affect operation, hamper cooling air circulation, and damage electrical and electronic components.
- Do NOT connect the appliance's drain connection to any drain material that cannot sustain 180° F.
- Do NOT connect any other drain from any other equipment to the drain line of this appliance.
- Do NOT connect the drain outlet extension line directly into a floor drain or a sewer line.
- Do NOT connect this appliance's drain directly to drains or to the plumbing of any other equipment.
- Do NOT install a trap or shutoff in the drain line.

DRAINPIPE SIZE AND LENGTH GUIDELINES

- Do NOT make a drainpipe outlet extension more than 12' long.
- Do NOT use more than three elbows.
- Up to 6' pipe: 1-1/2-inch pipe and fittings are acceptable.
- Up to 2 elbows: 1-1/2-inch pipe and fittings are acceptable.
- 6' to 12' pipe: 2-inch pipe and fittings are required.
- 3 elbows on any extension: 2-inch pipe and fittings are required.

CONNECTION

Refer to Dimensions and the Typical Drain Layout figure.

1. Connect the drain to the appliance.
2. While assembling the pipes and fittings of the drain outlet extension, use non-hardening pipe thread sealant.
3. Thread fittings together FINGER TIGHT ONLY! DO NOT USE A WRENCH!

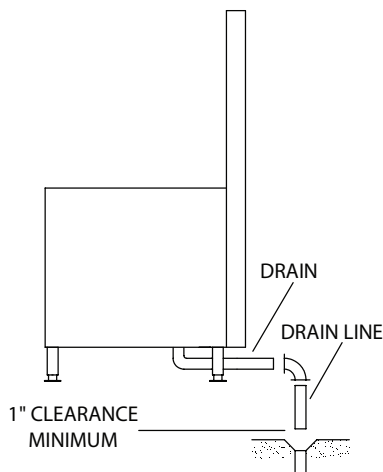

Typical Drain Layout

Direct Connect Steamer/Kettle Connections

Steam supply piping connects to the input side of the line steamer. Location and pressure data are shown on the specification sheet.

1. Provide a branch steam supply line that is 3/4" IPS minimum to ensure an adequate volume of steam. Direct-steam-connected kettles require 1/2" IPS pipe if the kettle's total capacity is 20 gallons or less, and 3/4" IPS pipe if the total capacity exceeds 20 gallons.
2. Flush the steam line thoroughly before connecting it to the steamer.
3. Provide a permanent 115 volt electrical connection at the junction box. The junction box location is shown on the specification sheet. Ground the unit electrically.

NOTE: Pressure steamers equipped with strictly manual steam and drain valves do not require an electrical connection.

Steam Coil Steam Generator Connections

Steam supply piping connects to the input side of the steam coil. Location and pressure data are shown on the specification sheet.

1. Provide a branch steam supply line that is 3/4" IPS minimum to ensure an adequate volume of steam.
2. Regulate incoming steam pressure to between 35 and 45 psi.
3. Supply and install a 3/4" strainer, equipped with a 20 mesh stainless steel screen, at the incoming steam connection point.
4. Flush the steam line thoroughly before connecting it to the steamer.
5. Fill the inverted bucket trap with water, and connect the trap to the outlet end of the steam coil.
6. Provide a permanent 115 volt electrical connection at the junction box. The junction box location is shown on the specification sheet. Ground the unit electrically.

Gauge Pressure Readings

Equipment	Gauge Pressure Reading with No Steam Flow (Static Pressure)							
	Self-Contained Steam Generator Gas or Electric			Self-Contained Steam Coil Generator			Direct Connect (To House Steam Supply)	
	Steamer's Pressure Reducing Valve	Operating Pressure Switch	High Limit Safety Pressure Switch	Operating Pressure Switch	High Limit Safety Pressure Switch	Steam Supply Pressure Range	Steamer's Pressure Reducing Valve	Steam Supply Pressure Range
Steam Generator Only – 5 psi	N/A	5 psi	10 psi	5 psi	10 psi	30-45 psi	N/A	N/A
Pressure Steamer	N/A	5 psi	10 psi	5 psi	10 psi	30-45 psi	5 psi	12-45 psi
Pressure Steamer with Any Kettle(s)	5 psi	10 psi	15 psi	5 psi	10 psi	*30-45 psi	5 psi	12-45 psi
Steam Generator Only – 10 psi	N/A	10 psi	15 psi	10 psi	15 psi	30-45 psi	N/A	N/A
Kettle Only – All	N/A	10 psi	15 psi	N/A	N/A	N/A	N/A	5-45 psi
Convection Steamer with or without Kettles	N/A	10 psi	15 psi	10 psi	15 psi	*35-45 psi	10 psi	15-45 psi

* Kettles are to be connected to the house steam supply.

Installation Checklist

Installation Check List		
TASK	REFERENCE Section	COMPLETED (Initial and Date)
Preparation	Section 2 & Spec Sheet	
Check Operating Location Clearances	Section 2	
Test Supply Water Quality	Section 2	
Water Supply Requirements Met	page 16	
Electric Power Requirements Met	Rating Plate, Section 2	
Gas Supply Requirements Met	Rating Plate, Section 2	
Exhaust Hood Requirements Met	Section 2	
Installation	Section 2	
Check Level Front-to-Back and Side-to-Side	Section 2	
Check Drain Line Connecton	Section 2	
Check Exhaust Hood Function	Section 2	
Check Electrical Supply Connection	Section 2	
Check Water Supply Connection	Section 2	
Leak Test Water Supply Lines	Section 2	
Check Gas Supply Connection	Section 2	
Leak Test Gas Supply Connection	Section 2	

Notes:

Steam Generator Controls

BOILER PRESSURE GAUGE CONTROL PANEL – GAS UNITS

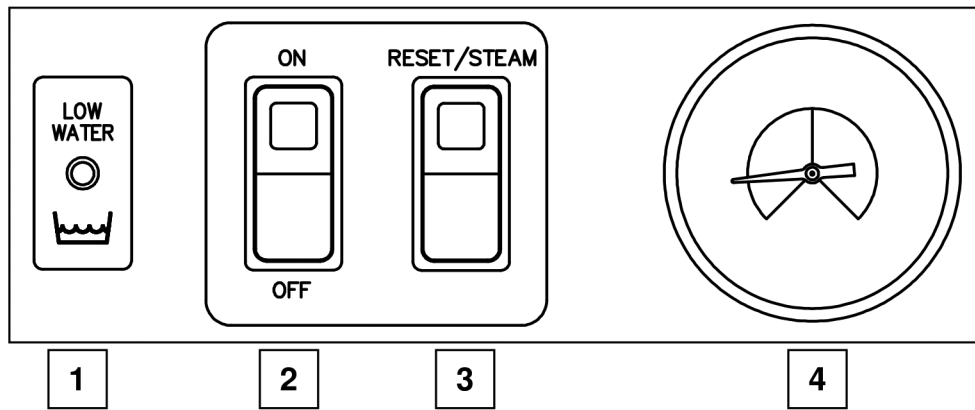

**Control Panel – Gas Units
(Not to Scale)**

1. Low Water Indicator Light
 - a. A lit red light indicates the water in the boiler is below operating level.
 - b. If this light turns ON during operation, turn the ON/OFF switch OFF and call an authorized service representative or Cleveland Range.
 - c. This light is ON while the Boiler fills.
 - d. If the Boiler does not fill:
 - Turn the ON/OFF switch OFF, turn the water supply OFF and clean the water line strainer.
 - Turn the water supply back ON and turn ON the ON/OFF switch.
 - If the boiler still does not fill, call an authorized service representative or Cleveland Range.
2. On/Off Switch
 - a. Turn this switch ON to power the control panel and fill the boiler.
3. Reset/Steam Switch
 - a. In normal use, press to light the burner after the red Low Water light turns OFF and the amber light turns ON.
 - b. If the amber light appears during use, a safety has tripped. Correct the problem and press to reset. (See the *Troubleshooting Guide*.)
4. Boiler Pressure Gauge
 - a. This gauge shows operating and unsafe pressure ranges.
 - b. If the boiler pressure is too high, turn the ON/OFF switch OFF and call an authorized service representative or Cleveland Range.

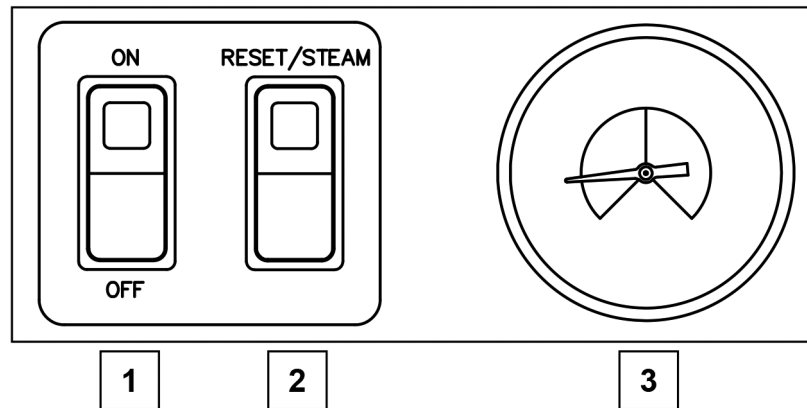
BOILER PRESSURE GAUGE CONTROL PANEL – ELECTRIC UNITS INCLUDING STEAM COIL

**Control Panel – Electric Units
(Not to Scale)**

1. On/Off
 - a. Turn this switch ON to power the control panel and fill the boiler.
 - b. If the boiler does not fill:
 - Turn the ON/OFF switch OFF, turn the water supply OFF and clean the water line strainer.
 - Turn the water supply back ON
 - If the boiler still does not fill, call an authorized service representative or Cleveland Range.
2. Reset/Steam Switch
 - a. In normal use, press to light the burner after the amber light turns ON.
 - b. If the amber light appears during use, a safety has tripped. Correct the problem and press to reset. (See the *Troubleshooting Guide*.)
3. Boiler Pressure Gauge
 - a. This gauge shows operating and unsafe pressure ranges.
 - b. If the boiler pressure is too high, turn the ON/OFF switch OFF and call an authorized service representative or Cleveland Range.

Section 3

Start-Up Procedure — Gas Fired Units

DANGER

DO NOT TRY TO LIGHT BURNERS WITH A FLAME

This appliance has an electronic ignition system, which automatically lights burners, senses flame, and controls gas flow.

Burners cannot be lit with a flame. DEATH, INJURY, OR EQUIPMENT DAMAGE may result from trying to light burners with a flame.

DANGER

Without power, there is NO safe method of operation of this appliance.

DO NOT ATTEMPT TO START OR OPERATE this appliance during a power failure. DEATH, INJURY, AND/OR EQUIPMENT DAMAGE may result.

Important

Problems? See the Installation Troubleshooting Guide at the end of this manual.

Burner Ignition Test (Lighting and Shutdown Instructions)

NOTE: Perform this test before Start-Up Test Procedure

NOTE: For new installations, or when air in gas lines is suspected, it may be necessary to bleed the air from the gas lines. Bleed air as close as possible to the inlet of the automatic gas valve.

LIGHTING INSTRUCTIONS (TEST OF FUNCTION OF PILOT LIGHT AND BURNER IGNITION SYSTEM) FOR GAS

1. If not already done:
 - A. Test the water supply lines.
 - B. Open the 1/4" manual water valve (ball valve).
 - C. Close the 3/4" drain valve (ball valve).
 - D. Leak test the gas supply lines.
 - E. Check that the ON/OFF valve of automatic gas control valve is in the ON position.
 - F. Open the Main Manual Gas Valve.
2. Turn the Main External Power Switch OFF.
3. Control Panel Settings (if applicable):
 - A. ON/OFF Switch: OFF. (If ON/OFF model.)
 - B. MANUAL/TIMED Switch: TIMED. (If dial timer model.)
 - C. TIMER DIAL: 0 minutes. (If dial timer model.)
4. Turn ON the electrical power to the appliance at the Main External Power Switch.
 - A. When initial power is supplied to the appliance with the ON/OFF switch in the OFF position, a 3-minute automatic blowdown cycle starts.
 - B. This cycle drains and rinses the float chamber and the drain valve.
 - C. This cycle stops after 3 minutes OR when the ON/OFF switch is changed to the ON position.
5. Turn ON the electrical power to the appliance at the ON/OFF switch.
 - A. The red indicator in the ON/OFF switch lights.
 - B. The red "Low Water" indicator lights.
 - C. The Boiler fills with water.
 - D. The "Low Water" indicator goes out.
 - E. The burner does NOT light.
 - F. The amber indicator in the Reset/Steam switch lights.

6. PRESS the Reset/Steam switch.
 - **EITHER:** The igniter initiates a spark and gas is supplied to the pilot for 90 seconds.
 - **OR:** If the pilot does not light in 90 seconds, then the ignition system locks out.
 - A. Reset system by waiting 5 minutes.
 - B. Turn the Main External Power Switch OFF and back ON.
 - C. PRESS the Reset/Steam switch.
 - D. If burner does NOT light after two attempts, go to Step 8.
7. When the burner lights, the Boiler begins heating and Boiler pressure rises to operating pressure as indicated by the Boiler Pressure Gauge.
 - A. After the operating pressure is reached, the burners cycle on and off to maintain operating pressure.
 - B. End this test here and go to the Shutdown Instructions.
8. Wait 5 minutes and then repeat Steps 2-6 up to three more times.
 - **EITHER:** If the burner does NOT light after repeating Steps 2-6 four times, go to the Shutdown Instructions and call a qualified Cleveland Range authorized service representative to adjust the burner controls.
 - **OR:** If the burner lights in four or less tries of Steps 2-6, go to Step 7.

SHUTDOWN INSTRUCTIONS

1. Turn OFF the electrical power to the appliance, at both the ON/OFF Switch and the Main External Power Switch.
2. Turn OFF the gas supply at Main Manual Gas Valve.

Section 4

Start-Up Procedure — Electric Units

DANGER

Without power, there is NO safe method of operation of this appliance.

DO NOT ATTEMPT TO START OR OPERATE this appliance during a power failure. DEATH, INJURY, AND/OR EQUIPMENT DAMAGE may result.

Important

Problems? See the Installation Troubleshooting Guide at the end of this manual.

Start-Up (Start-Up and Shutdown Instructions)

NOTE: Perform this test before Start-Up Test Procedure

START-UP INSTRUCTIONS

1. If not already done:
 - A. Test the water supply lines.
 - B. Open the 1/4" manual water valve (ball valve).
 - C. Close the 3/4" drain valve (ball valve).
2. Turn the Main External Power Switch OFF.
3. Control Panel Settings (if applicable):
 - A. ON/OFF Switch: OFF. (If ON/OFF model.)
 - B. MANUAL/TIMED Switch: TIMED. (If dial timer model.)
 - C. TIMER DIAL: 0 minutes. (If dial timer model.)
4. Turn ON the electrical power to the appliance at the Main External Power Switch.
 - A. When initial power is supplied to the appliance with the ON/OFF switch in the OFF position, a 3-minute automatic blowdown cycle starts.
 - B. This cycle drains and rinses the float chamber and the drain valve.
 - C. This cycle stops after 3 minutes OR when the ON/OFF switch is changed to the ON position.

5. Turn ON the electrical power to the appliance at the ON/OFF switch.
 - A. The red indicator in the ON/OFF switch lights.
 - B. The Boiler fills with water.
 - C. The heater does NOT start.
 - D. The amber indicator in the Reset/Steam switch lights.
6. PRESS the Reset/Steam switch.
7. The Boiler begins heating and Boiler pressure rises to operating pressure as indicated by the Boiler Pressure Gauge.
 - A. After the operating pressure is reached, the burners cycle on and off to maintain operating pressure.
 - B. End this test here and go to the Shutdown Instructions.

SHUTDOWN INSTRUCTIONS

1. Turn OFF the electrical power to the appliance at the ON/OFF Switch.
2. Turn OFF the electrical power to the appliance at the Main External Power Switch.

THIS PAGE INTENTIONALLY LEFT BLANK

Section 5

Operating Tests

Start-Up Test Procedure for the Boiler Bases, Gas-Fired and Electric

This procedure evaluates the function of the operating controls of this appliance.

START-UP PROCEDURE WITH THE APPLIANCE DE-ENERGIZED

1. Start with the Main External Power Switch OFF.
2. Check the fuses or circuit breakers for proper size.
3. Make sure the water supply line valves are open.
4. Make sure the Main Manual Gas Valve is open.
5. Continue with Boiler Drain and Rinse Cycle Inspection.

DANGER

ELECTRIC SHOCK HAZARD

DEATH, INJURY, or EQUIPMENT DAMAGE can result from touching any component inside this appliance when the power is connected.

Whenever possible disconnect the power while installing, servicing, or testing this appliance.

When installation, service, or tests require power to be connected to this appliance: use extreme caution and every possible precaution and safety measure while testing or servicing this appliance.

BOILER DRAIN AND RINSE CYCLE INSPECTION (3-MINUTE BLOWDOWN CYCLE)

1. Turn OFF the Main External Power Switch.
2. Turn OFF the ON/OFF switch.
3. Turn the Main External Power Switch ON to start the 3-Minute Blowdown Cycle.
 - A. Watch for plumbing leaks:
 - B. If there are leaks:
 - Turn OFF the Main External Power Switch.
 - Repair leaks.
 - Start this test over.
4. The automatic blowdown cycle opens the fill and rinse valves.
5. The drain valve remains open.
6. Stop the blowdown cycle before it is complete by turning the ON/OFF switch ON.
 - A. The operating controls energize
 - B. The red ON indicator in the ON/OFF switch lights.
 - C. Blowdown stops
 - D. The Boiler fills
 - The Low Water light turns ON while the Boiler is filling.
 - The Low Water light turns OFF when the Boiler is full.
7. Start a 3-minute blowdown cycle by turning the ON/OFF switch OFF.
8. A steady stream of water flows from drainpipe into the floor drain.
9. After the 3-minute blowdown cycle ends, no water flows into the float column or out of the drainpipe.
10. Continue with Operating Test Procedures.

OPERATING TEST PROCEDURES

1. Turn OFF the Main External Power Switch.
2. Turn OFF the ON/OFF switch.
3. Turn ON the Main External Power Switch.
 - A. The 3-minute blowdown cycle starts.
 - B. Turn the ON/OFF switch ON.
 - The red ON indicator in the ON/OFF switch lights.
 - The automatic blowdown cycle stops.
 - C. Water rises in the sight glass.
 - D. When water reaches the safety level sensor AND there is NO pressure in the Boiler, the amber light in the Reset/Steam switch lights.
 - E. Press the Reset/Steam switch to light the burner.
 - F. The amber light goes out, the burner lights, and Boiler pressure rises to operating level.
 - G. Check the Low-Water Safety Circuit:
 - Let the appliance continue to steam in MANUAL mode.
 - Close the Main Water Shutoff Valve. Water steams out of the Boiler. Water in the Boiler drops below the safety level sensor. The burner shuts OFF.
 - Open the Main Water Shutoff Valve. The Boiler refills to the safety level and the amber light in the Reset/Steam switch lights.
 - Press the Reset/Steam switch to resume steaming.
 - H. Turn the ON/OFF switch OFF.
 - I. Wait for blowdown to end.
 - J. Turn OFF the Main External Power Switch.
 - K. Replace all panels and sheeting.
 - L. Turn ON the Main External Power Switch.

Section 6

General Information on Kettle on Boiler Bases

Product Information

For details on product information and installation of Kettles on Boiler Bases, refer to KETTLES manual (KE004008 A). A copy can be requested by contacting Cleveland Range sales representative or Cleveland Range.



Section 7

Maintenance (KETTLE & Steam Generator)

General Information

Follow the maintenance instructions and schedules to help keep the appliance working properly.

Increase the frequency of maintenance as needed depending on use and water quality.

Contact your qualified Cleveland Range authorized service agency or Cleveland Range for more information about maintenance scheduling, products, and services.

Maintenance and Service Records

1. Make a file just for maintenance records.
2. Keep a written record of daily, weekly, monthly, and yearly maintenance, descaling, service, and repair. Each record must include at least:
 - a. The date of the maintenance, descaling, service, or repair.
 - b. A description of the service, maintenance, or repair performed.
 - c. Copies of purchase order(s) and invoice(s) for repair parts and service, descaling, maintenance, and repair. Include part numbers, if applicable.
 - d. The name and signature of the person performing the service, maintenance, or repair.

DANGER

HIGH HEAT HAZARD

Wait for this appliance to cool before cleaning! Attempting to clean a hot appliance can cause DEATH, INJURY, BURNS, and SCALDS.

Clean After Cooking (KETTLE)

Your kettle must be cleaned regularly to maintain its fast, efficient cooking performance, and to ensure its continued safe, reliable operation.

Caution

Do not use chlorine base detergent.

Caution

Steel wool should never be used for cleaning the cooking chamber of the kettle. Particles of steel wool become embedded in the cooking surface and rust, and may corrode the stainless steel.

1. Prepare a warm water and mild detergent solution in the kettle.
2. Remove food soil inside the kettle using a nylon brush. Do not use a metal bristle brush as this may permanently damage the kettle's stainless steel surface.
3. Loosen food which is stuck to the kettle by allowing it to soak at a low temperature (simmer or low boil).
4. Tilt kettle forward to drain the wash water.
5. Rinse the kettle interior thoroughly, then drain rinse water.
6. Leave the cover and steam control valve open when the kettle is not in use.
7. Using mild soapy water and a damp sponge, wash the exterior of the kettle, rinse, and dry.

NOTE: For more difficult cleaning applications, one of the following can be used: alcohol, baking soda, vinegar, or a solution of ammonia in water. Avoid the use of chloride cleansers, which may damage the kettle's stainless steel surface.

STEAM GENERATOR (2 PROBE TYPE) MAINTENANCE PROCEDURES

CAUTION: Service on the generator must be performed only by trained and experienced service technician, thoroughly familiar with servicing steam generators. No work should be done on the steam generator while it is pressurized or hot. Be sure all energy sources are shut off before the start of any work.

The steam generator must be drained under pressure (blowdown) after a maximum of 8 hours of use. If the generator's feedwater contains more than 300 parts per million of total dissolved solids, the generator must have a blowdown after each 4-6 hours of use. "Slowdown" means the generator must be drained under pressure.

THE GENERATOR "SLOWDOWN" IS PERFORMED BY SHUTTING OFF THE UPPER RED-LIGHTED "POWER" SWITCH WHILE THE GENERATOR IS AT NORMAL OPERATING PRESSURE. WHEN THE BOTTOM OF THE "POWER" ROCKER SWITCH IS PUSHED, ITS RED LIGHT GOES OUT, AND THE DRAIN VALVE AUTOMATICALLY OPENS. DRAINING THE GENERATOR. AN AUTOMATICALLY-TIMEO SOLENOID VALVE WILL FLUSH THE DRAIN FOR 3 MINUTES, THEN SHUT OFF. AFTER 3 MINUTES, THE UNIT CAN BE RESTARTED.

Even though the "Slowdown" is performed faithfully each day, it will still be necessary to have a qualified service technician periodically inspect the inside of the generator for scaling or pitting. The generator's hand hole plate should be removed at regular intervals, so that it and the inside of the generator can be inspected. The hand hole plate should be cleaned and examined each time it is removed. If the hand hole plate is chipped or cracked, or over three years old, install a new one. A new hand hole gasket should always be installed.

Descaling (Steam Generator)

Scaling indicates a high concentration of dissolved minerals in the feed water. Pitting indicates an excess acid condition. The best way to reduce servicing time and to assure a long generator life is to provide feed water that is low in mineral content and low in gas content. Water that is fit to drink can still be high in impurities that are highly detrimental to a steam generator. Consult the state department of water for an on-the-premises water analysis and for recommendations concerning steam generator feed water treatment (if required), in order to remove or reduce harmful concentrations of minerals.

CAUTION: Never tighten the hand hole plate nut when the steam generator is in use, hot, or otherwise pressurized. Never tighten nut over 15 foot-pounds torque. Overtightening may cause uneven stress, which may result in the weakening and possible breakage of the plate.

The "Slowdown" procedure will not completely remove the mineral deposits that adhere to the top of the generator.

It will be necessary to periodically have scale accumulations removed from the inside of the steam generator by a qualified service technician. Note: Boilers should be descaled once every four months, or more often depending on scale buildup. Note the date of descaling in your maintenance and service records to help keep boiler descaling on schedule.

Descaling Procedure using the Descaling Pump System

- Cleveland Range recommends that your service agency descales your boiler
- If you have trained and skilled in-house maintenance personnel, you may wish to discuss purchasing Descaling pump system P/N: 107142 for use with Dissolve Descaler Solution P/N 106174 with your sales representative or service agency.
- Use no other system of descaling
- For details on Descaling procedure using Descaling Pump System, refer to KE004041 B

Failure to periodically remove scale from the inside of the generator will result in greatly reduced generator life.

Check the safety valve once a month while the steam generator is pressurized. Test by pulling the safety valve lever. The valve must open freely and snap closed when released. If it does not, or if it drips constantly, a new safety valve is needed.

If the steam generator is to be left idle for three months or more, it should be drained and dried out and the hand hole plate left off.

Section 8 Troubleshooting Guide

The Troubleshooting Guide is a list of symptoms of problems that may occur during routine operation.

- “Problem” (left column) lists common operating problems.
- “Possible Cause” (center column) lists causes of problems in the order they should be checked.
- “Remedy / Reference” (right column) lists fixes for problems from easiest to hardest.

ATTEMPTING TO REPAIR OR CORRECT PROBLEMS REQUIRING A QUALIFIED CLEVELAND RANGE AUTHORIZED SERVICE REPRESENTATIVE VOIDS THE WARRANTY

Troubleshooting Guide (KETTLE)

Problem	Possible Cause	Remedy/Reference
Kettle heats too slowly or does not come to a boil.	Inadequate steam flow.	Check for correct steam using chart below. If kettle is connected to a steamer and powered by a generator, the units should be operated sequentially (kettle boiling first, then start steamer).
	Steam trap not operating properly.	The trap should open periodically to dump condensate, then close. If it does not open or close, it should be cleaned or replaced.
	Food batches are not always the same.	When checking, make certain that the original state (ie. fresh or frozen) and quantity of food product is the same.
The trunnion housing (steam inlet and/or condensate return) leaks steam.	Trunnion “O” rings are worn.	Replace “O” rings.

STEAM FLOW RATING OF STEAM GENERATORS

Gas Input BTU/Hour	Steam Output Lbs./ Hour	Boiler HP
100,000	60	1.7
160,000	95	2.8
200,000	125	3.6
250,000	150	4.4
300,000	180	5.2
Electric kW Input		
18 kW	60	1.7
24 kW	70	2.0
27 kW	90	2.6
36 kW	120	3.5
48 kW	150	4.3

STEAM FLOW RATE REQUIREMENTS FOR KETTLES

Capacity Gal./ (Liters)	Fast Cooking	Medium Cooking Speed	Stock Kettle
5 (17)	11	9	6
10 (42)	22	18	11
25 (95)	55	44	28
40 (151)	88	70	44
60 (227)	132	105	66

NOTE: Above shows lbs. per hour with 10-15 psig steam at the kettle. The use of higher steam pressure (20-25 psig) will reduce heat-up time 5 to 20%.

The Troubleshooting Guide is a list of symptoms of problems that may occur during routine operation.

- “Problem” (left column) lists common operating problems.
- “Possible Cause” (center column) lists causes of problems in the order they should be checked.
- “Remedy / Reference” (right column) lists fixes for problems from easiest to hardest.
- “Notes” in “Remedy / Reference” column are at end of the Troubleshooting Guide.

ATTEMPTING TO REPAIR OR CORRECT PROBLEMS REQUIRING A QUALIFIED CLEVELAND RANGE AUTHORIZED SERVICE REPRESENTATIVE VOIDS THE WARRANTY

Troubleshooting Guide (BOILER BASE)

Problem	Possible Cause	Remedy/Reference
Power indicator light does not turn ON when ON/OFF switch is in the ON position.	Power turned OFF at Main External Power Switch.	Turn ON power at Main External Power Switch.
	Inoperative controls.	See Note 1.
Power ON, low water indicator light is ON and Boiler does not fill. (See also Boiler drains continuously, below.)	Water supply to appliance shut off.	Open Main Water Shutoff Valve.
	Main Water Shutoff Valve to Boiler feed is closed.	Open manual valve in feed line located behind the sliding lower right side panel.
	Water line strainer is clogged.	Clean water supply strainer.
	Supply pressure is low. Inadequate water supply system.	Low supply pressure can cause long fill times. Make sure that compartments are turned OFF during the first Boiler fill. See Note 3.
	Inoperative solenoids or controls.	See Note 1.
Boiler drains continuously.	Manual drain valve is open.	Close manual drain valve located behind the lower right-side sliding panel.
	Drain valve is stuck partially open.	Turn ON/OFF switch to the OFF position for one minute to flush the drain valve. Turn the switch back to the ON position. See Note 4. If condition persists, see Note 1.
	Inoperative controls.	See Note 1.
Control panel POWER indicator light ON, low water indicator light is OFF, pressure reset switch light is ON and Boiler does not make steam. (Boiler Pressure Gauge reads zero.)	Boiler system needs reset.	Press RESET/STEAM switch. See Note 4.
Control panel POWER indicator light ON, low water indicator light, and pressure reset switch are OFF and Boiler does not make steam. Boiler will not light. (Boiler Pressure Gauge reads zero.)	Gas supply valve TO appliance is closed. (Gas units only)	Turn OFF Main External Power Switch and open gas supply valve. Turn Main External Power Switch ON. See Note 4.
	Gas supply valve IN appliance is closed. (Gas units only)	Turn OFF Main External Power Switch. See Note 1.
	Unit is locked out. (Gas units only)	See Note 4.
	Inoperative controls.	See Note 1.
Control panel POWER indicator light is ON, Boiler is pressurized and compartments will not cook.	Compartment door steam shut off switch (SCS): switch not engaged. (If appliance has this option.)	Close door completely.
	Inoperative controls or solenoids.	See Note 1.
Reduced steam.	Boiler supplying too much external equipment.	Adjust installation. See Note 2.
	Steam generator scale buildup.	Descale steam generator with Cleveland Range approved descaler.
Water leaking from water pipes or drain lines.	Plumbing needs repair.	See Note 3.

Problem	Possible Cause	Remedy/Reference
Water leaking from bottom of cabinet.	Broken or loose plumbing inside appliance cabinet.	Turn OFF power at Main External Power Switch. Close Main Water Shutoff Valve. See Note 1.
Amber light in reset switch lights, and Boiler stops producing additional steam. Low water light remains OFF.	High-pressure switch has been activated.	Turn OFF power. See Note 4. If condition repeats itself, turn off Main External Power Switch. See Note 1.
	Inoperative controls.	See Note 1.
Amber light in reset switch lights, and Boiler stops producing steam. Low Water Light is ON, or Low Water Light came ON briefly.	Water solenoid to the Boiler has failed.	See Note 1.
	Drain solenoid has failed.	See Note 1.
	Water pressure is low (or was low briefly).	Turn OFF power. See Note 4. If condition repeats itself, turn OFF Main External Power Switch. See Note 3.
	Manual drain is not completely closed.	Close manual drain completely (located on the front of the boiler).
	Inoperative controls	See Note 1.
Abnormal amount of steam coming from drain during drain cycle.	Flush solenoid has failed.	See Note 1.

NOTES

1. If the problem is inside the appliance, call a qualified Cleveland Range authorized service representative or Cleveland Range. (Please have the model number and serial number ready when calling.) Cleveland Range will not pay for warranty repairs by unauthorized maintenance and repair centers.
2. Proper installation of this appliance is the responsibility of the Owner-User. Refer to the Cleveland Range Warranty.
3. Repairs to external plumbing should be done by a Licensed Plumber.
4. To restart the unit, follow the Lighting (Start-Up) instructions in this manual.
5. Repairs to external wiring should be done by a Licensed Electrician.
6. For more information on products and services, contact your nearest Authorized Sales Representative.
7. Call Cleveland Range at 216-481-4900 for preventative maintenance programs, descaling kits, descaling information, and water treatment systems.

Water Level Control System Troubleshooting and Repair

The Cleveland Range water level control, P/N 23198, is designed to maintain operating water level in Cleveland Range steam generators and to ensure that the heat source is only operated when the generator water level is above a specified minimum level. The sensing technique for the control relies on the fact that tap water is conductive to electricity if two metal electrodes are immersed in a bath of water, electric current can flow between the electrodes using the water as a conductor. Water is not a good conductor, like copper, but is conductive enough to be measured using appropriate electronic circuitry.

The Cleveland Range control is a two probe system having two metallic probes (LOW and HI) for sensing water in the generator; a COM terminal is placed on the tank. The LOW probe is placed so that it will come in contact with the water when the water level is just above the desired water level, enough to protect the heat source. If the water is at sufficient level and the LOW probe is in the water, a small electrical current provided by the level control electronics will flow between the probe and COM; this flow will be sensed by the electronics which in turn will activate the "HEAT" relay to apply AC power to the HEAT terminal on the control circuit board.

Similarly, the HI probe is located at the desired water level fill (above the LOW probe level) so that when the water level has reached the desired fill level electrical current will flow between the HI probe and COM. The action of this probe is reversed from the previous situation so that when water reaches the HI probe, the WF terminal will be re-energized after a five second delay. The time delay is to prevent bubbling or turbulence in the generator from chattering to water fill relay or the water valve solenoid.

The control runs on 120vac and is transformer isolated so that the probes and the electronics are run at low voltage and are not common to the AC power line.

Note that in many Cleveland Range generators both sensing probes are inserted from the front top of the unit down into the generator. In this case, the Low probe will be the longest and the HI probe will be the shortest.

A. SYMPTOMS OF WATER LEVEL CONTROL RELATED PROBLEMS:

- 1) Boiler overfills or floods
- 2) Boiler dry fires (system under-fills or doesn't fill)
- 3) Boiler doesn't fill at all
- 4) water fill solenoid chatter
- 5) Beater contactor chatter
- 6) Fills but cuts out on LOW WATER before filling again
- 7) Overfills but does not heat
- 8) Fills but does not heat

B. POSSIBLE CAUSES:

- 1) Inoperative water level control circuit board (P/N 23198)
- 2) Incorrect or **damaged wiring** to probes
- 3) Incorrect or damaged wiring from water level. board to loads
- 4) **Damaged** probes
- 5) Probes shorted together
- 6) Scale build-up on probes

C. FAULT Isolation PROCEDURE:

Equipment Required: Volt/Ohmmeter (**VOM**) or Multimeter

STEP	TEST	RESULT	REMEDY
1.	Is power applied to the control circuit board? Measure L1-L2 at the board to be 120 VAC \pm 15V.	Yes No	Go to Step #2 Correct external supply problem
2.	Remove two AC power wires from control board and connect ohmmeter to control board power terminals. Is resistance between 100-1000 ohms?	Yes No	Reconnect power and go to Step #3 Replace control board P/N 23198 (inoperative transformer)
3.	Visually inspect probe wiring for damaged or broken wires or loose or missing terminals at either end. Is wiring visually OK?	Yes No	Go to step #4 Replace wiring as required

STEP	TEST	RESULT	REMEDY
4.	Are the following connections made correctly?	Yes	Go to Step #5
	A) COM input on board to boiler ground	No	Correct probe wiring as required (see Figure 1)
	B) LO input on board to long length "LO" probe		
	C) HI input on board to short "HI" probe		
5.	Temporarily disconnect the wire from the HTR terminal so that the heat source will not operate. Is the heat source off?	Yes	Go to Step 16
		No	Check heat source and wiring in cooker
6.	With HTR still disconnected, disconnect the LOW wire at the LOW terminal of the control board. Measure the AC line voltage between the HTR and L2 terminals on the control board. Is the voltage 0 vac? NOTE: Digital meters may read a few volts due to their high input impedance; this should be considered as 0 vac.	Yes	Go to Step #7
		No	Replace water level control P/N 23198
7.	Short the LOW and COM terminals on the control board. Does the AC line voltage between the HTR and L2 terminals now read 120 vac (line voltage)?	Yes	Reconnect HTR & LOW wires and go to Step #8
		No	Replace water level control P/N-23198
8.	Disconnect the wires from the HI and COM terminals on the control board and short the HI & COM terminals together. Measure the AC line voltage between the WF and L2 terminals. Is the voltage 0 vac?	Yes	Go to Step #9
		No	Replace water level control P/N 23198

STEP	TEST	RESULT	REMEDY
9.	Remove the short from the HI and COM terminals on the control board. Does the AC line voltage between WF and L2 stay at 0 vac for about five seconds, then jump to 120vac?	Yes	Reconnect HI & COM wires and go to Step #10
		No	Replace water level control P/N: 23198
10.	Drain all water from the generator. Disconnect the wires from the LO, HI, & COM terminals at the control board. Connect an Ohmmeter across the LO and COM wires leading to the generator. Does the Ohmmeter read greater than 100,000 ohms?	Yes	Go to Step #12
		No	Go to step #11
11.	Disconnect the LO wire at the water sensing probe on the generator. Does the Ohmmeter connected in the previous step now read greater than 100,000 ohms?	Yes	Go to Step #12
		No	Replace probe wiring
12.	Reconnect the ohmmeter across each end of the disconnected LO wire. Does the ohmmeter read less than 10 ohms?	Yes	Go to Step #13
		No	Replace wire
13.	Connect an ohmmeter across the HI and COM wires leading to the generator. Does the ohmmeter read greater than 100,000 ohms?	Yes	Go to step #15
		No	Go to Step #14
14.	Disconnect the HI wire at the water sensing probe on the generator. Does the ohmmeter connected in the previous step now read greater than 100,000 ohms?	Yes	Replace probe wiring
		No	Go to Step #16
15.	Reconnect the ohmmeter across each end of the disconnected HI wire. Does the ohmmeter read less than 10 ohms?	Yes	Go to step #16
		No	Replace probe wiring

STEP	TEST	RESULT	REMEDY
16.	Reconnect one lead of the ohmmeter to the COM wire at the control board and connect the other ohmmeter lead to generator ground. Does the ohmmeter read less than 10 ohms?	Yes	Reconnect HI, LOW & COM wires at control board only. Go to Step #17.
		No	Replace probe wiring
17.	Reconnect the ohmmeter across the LOW terminal at the sensing probe & generator ground. Does the ohmmeter read greater than 100,000 ohms?	Yes	Go to Step #18
		No	Replace probe assembly
18.	Reconnect the ohmmeter across the HI terminal at the sensing probe & generator ground. Does the ohmmeter read greater than 100,000 ohms?	Yes	Go to Step #19
		No	Replace probe assembly
19.	Remove probe and check for scale buildup on or across probes. Replace probe assembly as required.		

Every new piece of Welbilt Foodservice equipment comes with KitchenCare® and you choose the level of service that meets your operational needs from one restaurant to multiple locations

StarCare – Warranty & lifetime service, certified OEM parts, global parts inventory, performance audited

ExtraCare — CareCode, 24/7 Support, online/mobile product information

LifeCare – Install & equipment orientation, planned maintenance, KitchenConnect™, MenuConnect®

Talk with KitchenCare® • 1-844-724-CARE • www.mtwkitchencare.com



To learn how Welbilt Foodservice and its leading brands can equip you, visit our global web site at www.welbilt.com, then discover the regional or local resources available to you.