

## SERVICE

	<p><b>ELECTRIC SHOCK HAZARD.</b></p> <p>Turn off all power to unit before servicing. The ENABLE/OFF/REMOTE CONTACT switch on control panel does <i>not</i> shut off control power; <i>use field disconnect.</i></p>
---	---

### Electronic Components

**CONTROL COMPONENTS** — Unit uses an advanced electronic control system that normally does not require service. For details on controls refer to Operating Data section.

Access to the compressors is through latched panels from beneath the control box on all models or from opposite the coil side (sizes 010-030 only). The front door(s) provide access to the compressor(s) and all components of the refrigeration system. For size 010-030 units, access to the controls is through the upper latched outer door above the compressor access door. Similarly, the upper center latched door on sizes 032-055 gives access to the controls. Inner panels are secured in place and should not be removed unless all power to the chiller is off.

**Compressor Replacement (Refer to Fig. 27-30)** — All models contain scroll compressors and have from one to four compressors. The size 010-030 units are a single refrigeration circuit while sizes 032-055 are dual circuit. A compressor is most easily removed from the front of the unit, depending on where clearance space was allowed during unit installation.

Unscrew the junction box cover bolts and disconnect the compressor power and ground connections. Remove the cable from the compressor junction box. Remove the connections from the internal thermostat and high-pressure switch (all compressors except SM110) or high-pressure switch connections (SM110 only). Knock the same holes out of the new compressor junction box and install the cable connectors from the old compressor. Remove the blockoff channel from below the control box.

Be sure the oil equalization line fitting is removed from the old compressor and installed on the new compressor for those models with dual compressor circuits. The compressors are bolted to the unit basepan. Remove the 4 bolts holding the compressor to the basepan. Save the mounting hardware for use with the new compressor. Carefully cut the compressor suction and discharge lines with a tubing cutter as close to the compressor as feasible. For dual compressor circuits, do NOT disturb the suction line tee at the backside of the compressors. This tee contains a special tube that is required for proper oil return. Remove high-pressure switch and pressure transducer(s) if required for compressor removal. Lift one corner of the compressor at a time and remove all the rubber mounting grommets. Remove the old compressor from the unit.

Slide the new compressor in place on the basepan. Lifting one side of the compressor at a time, replace all of the compressor mounting grommets. Using new tubing or couplings as required, reconnect compressor suction and discharge lines. Using hardware saved, reinstall the mounting bolts and washers through the compressor feet. Using proper techniques, braze suction and discharge lines and check for leaks. Reconnect oil equalization line on dual compressor circuit models.

Reconnect the compressor power connections and high-pressure switch/internal thermostat wiring as on the old compressor. Refer to Fig. 27-30. Following the installation of the new compressor, tighten all hardware to the following specifications. (See Table 30.)

**Table 30 — Unit Torque Specification**

FASTENER	RECOMMENDED TORQUE
<b>Compressor Mounting Bolts</b>	10 to 14 ft-lb (13.5 to 18.9 N-m)
<b>Compressor Power Connections</b>	24 to 28 in.-lb (2.7- to 3.2 N-m)
<b>Compressor Ground Terminal Connections</b>	14 to 18 in.-lb (1.6 to 2.0 N-m)
<b>Oil Equalization Line Fitting</b>	10 to 13 ft-lb (13.5 to 17.6 N-m)

### Cooler

**BRAZED-PLATE COOLER HEAT EXCHANGER REPLACEMENT** — Brazed-plate heat exchangers cannot be repaired if they develop a leak. If a leak (refrigerant or water) develops, the heat exchanger **must be** replaced. To replace a brazed plate heat exchanger:

1. Disconnect the liquid-in and liquid-out connections at the heat exchanger.
2. Check that the replacement heat exchanger is the same as the original heat exchanger. The unit insulation covers the manufacturer's part number. Make sure the depths of the replacement and original cooler heat exchangers are the same.
3. Reclaim the refrigerant from the system, and unsolder the refrigerant-in and refrigerant-out connections.
4. Remove the old heat exchanger and the bracket that it is mounted to. The replacement heat exchanger is supplied attached to a new mounting bracket and is fully insulated. It also includes a cooler heater. Use of the heater is not required unless the original cooler contained a factory installed heater.
5. Install the replacement heat exchanger in the unit and attach the mounting bracket hardware to the fan uprights (sizes 010-030) or to the bottom bracket (sizes 032-055) using the hardware removed in Step 4. Reconnect the cooler heater if required.
6. *Carefully* braze the refrigerant lines to the connections on the heat exchanger. Lines should be soldered using silver as the soldering material with a minimum of 45% silver. Keep the temperature below 1472 F (800 C) under normal soldering conditions (no vacuum) to prevent the copper solder of the brazed plate heat exchanger from changing its structure. Failure to do so can result in internal or external leakage at the connections which cannot be repaired.
7. Reconnect the water/brine lines.
8. Dehydrate and recharge the unit. Check for leaks.

**BRAZED-PLATE COOLER HEAT EXCHANGER CLEANING** — Brazed-plate heat exchangers must be cleaned chemically. A professional cleaning service skilled in chemical cleaning should be used. Use a weak acid (5% phosphoric acid, or if the heat exchanger is cleaned frequently, 5% oxalic acid). Pump the cleaning solution through the exchanger, preferably in a backflush mode. After cleaning, rinse with large amounts of fresh water to dispose of all the acid. Cleaning materials must be disposed of properly.

The factory-installed strainer screen in front of the water/brine inlets of the heat exchangers should be cleaned periodically, depending on condition of the chiller water/brine.

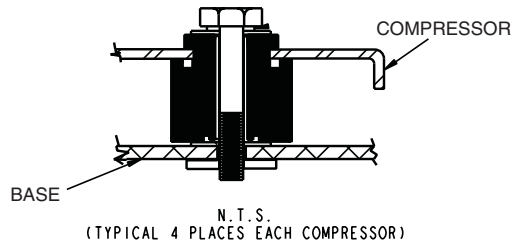

**Fig. 27 — Typical Compressor Mounting — All Sizes**

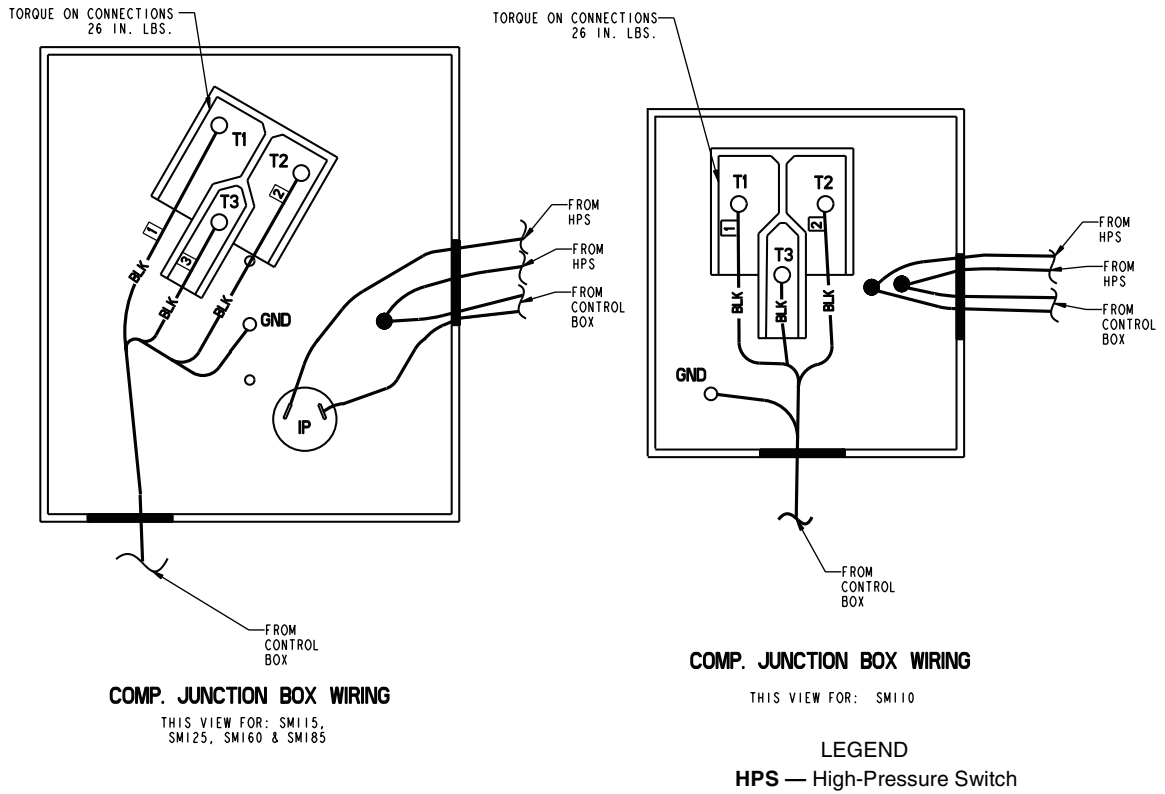

**Fig. 28 — Compressor Wiring**

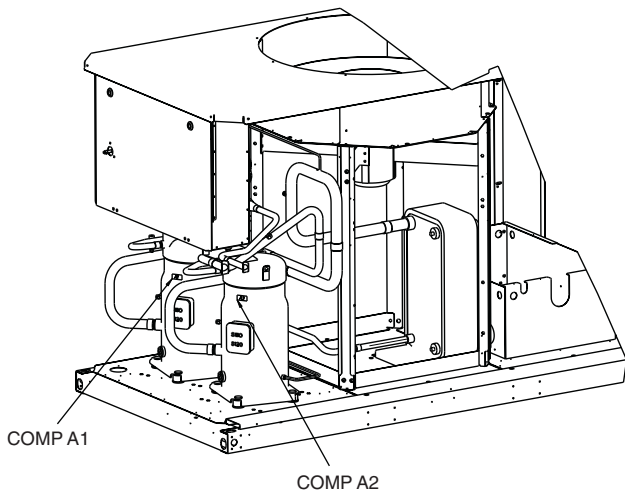

**Fig. 29 — Compressor Location — 30RA010-030**

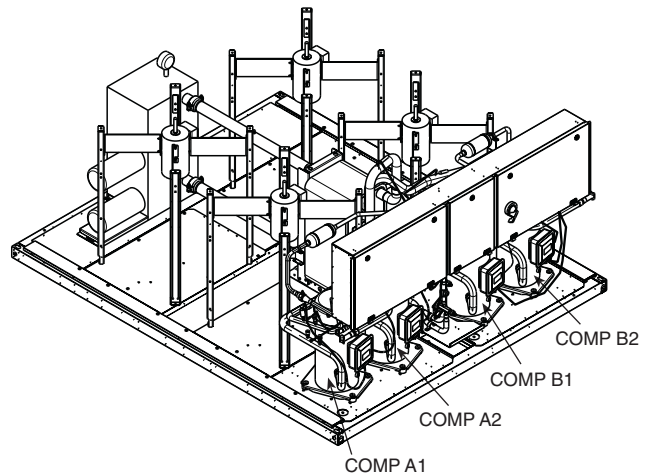

**Fig. 30 — Compressor Location — 30RA032-055**

**Check Oil Charge** — Compressors are factory charged with oil as shown in Table 31.

**Table 31 — Oil Charge**

COMPRESSOR	AMOUNT pints (liters)
SM110	5.7 (2.7)
SM115, SM125	6.7 (3.2)
SM160	7.0 (3.3)
SM185	11.6 (5.5)

If oil is visible in the compressor sight glass, check unit for operating readiness as described in Pre-Start-Up, System Check section (page 74), then start the unit. Observe oil level and add oil if required, to bring oil level in compressor crankcase up to between 1/4 and 3/4 of sight glass during steady operation.

To Add Oil:

1. Check the oil level with all compressors in the circuit running in a stabilized condition or immediately after compressor shutdown. The oil level should be at 1/3 of the oil sight glass immediately after shutdown.
2. Using a suitable pump, add oil while compressor(s) are running through the low side 1/4 in. Schraeder fitting on the compressor. For SM110 models, this fitting is directly above the suction line connection. For all other compressor models, this fitting is near the oil equalization line fitting at the same height as the suction line connection.
3. Run all compressors on the circuit for at least 15 minutes and check the oil level.

Use only Carrier-approved compressor oil:

Totaline ..... PP680002  
 Penreco ..... Sontex 160 LT-A

Do not reuse drained oil, and do not use any oil that has been exposed to the atmosphere.

**Condenser Section and Coils**

**COIL CLEANING** — For standard aluminum, copper and pre-coated aluminum fin coils, clean the coils with a vacuum cleaner, fresh water, compressed air, or a bristle brush (not wire). Units installed in corrosive environments should have coil cleaning as part of a planned maintenance schedule. In this type of application, all accumulations of dirt should be cleaned off the coil. When condenser cleaning is complete, enter “Yes” for coil cleaning maintenance done (CL.MN) value under Run Status.

**⚠ CAUTION**

Do not use high-pressure water or air to clean coils — fin damage may result.

**CLEANING E-COATED COILS** — Follow the outlined procedure below for proper care, cleaning and maintenance of E-coated aluminum or copper fin coils:

Coil Maintenance and Cleaning Recommendations — Routine cleaning of coil surfaces is essential to maintain proper operation of the unit. Elimination of contamination and removal of harmful residues will greatly increase the life of the coil and extend the life of the unit.

Remove Surface Loaded Fibers — Surface loaded fibers or dirt should be removed with a vacuum cleaner. If a vacuum cleaner is not available, a soft brush may be used. In either case, the tool should be applied in the direction of the fins. Coil

surfaces can be easily damaged (fin edges bent over) if the tool is applied across the fins.

**NOTE:** Use of a water stream, such as a garden hose, against a surface loaded coil will drive the fibers and dirt into the coil. This will make cleaning efforts more difficult. Surface loaded fibers must be completely removed prior to using low velocity clean water rinse.

Periodic Clean Water Rinse — A periodic clean water rinse is very beneficial for coils that are applied in coastal or industrial environments. However, it is very important that the water rinse is made with very low velocity water stream to avoid damaging the fin edges. Monthly cleaning as described below is recommended.

Routine Cleaning of Coil Surfaces — Monthly cleaning with Environmentally Sound Coil Cleaner is essential to extend the life of coils. It is recommended that all coils, including standard aluminum, pre-coated, copper/copper or E-coated coils are cleaned with the Environmentally Sound Coil Cleaner as described below. Coil cleaning should be part of the units regularly scheduled maintenance procedures to ensure long life of the coil. Failure to clean the coils may result in reduced durability in the environment.

Environmentally Sound Coil Cleaner is non-flammable, hypo allergenic, non-bacterial, USDA accepted biodegradable and 100% ecologically safe agent that will not harm the coil or surrounding components such as electrical wiring, painted metal surfaces or insulation. Use of non-recommended coil cleaners is strongly discouraged since coil and unit durability could be affected.

Environmentally Sound Coil Cleaner Application Equipment

- 2 1/2 Gallon Garden Sprayer
- Water Rinse with Low Velocity Spray Nozzle

Environmentally Sound Coil Cleaner Application Instructions

- Although Environmentally Sound Coil Cleaner is harmless to humans, animals, and marine life, proper eye protection such as safety glasses is recommended during mixing and application.
- Remove all surface loaded fibers and dirt with a vacuum cleaner as described above.
- Thoroughly wet finned surfaces with clean water and a low velocity garden hose being careful not to bend fins.
- Mix Environmentally Sound Coil Cleaner in a 2 1/2 gallon garden sprayer according to the instructions included with the Enzyme Cleaner. The optimum solution temperature is 100 F.

**NOTE: DO NOT USE water in excess of 130 F as the enzymatic activity will be destroyed.**

- Thoroughly apply Environmentally Sound Coil Cleaner solution to all coil surfaces including finned area, tube sheets and coil headers.
- Hold garden sprayer nozzle close to finned areas and apply cleaner with a vertical, up-and-down motion. Avoid spraying in horizontal pattern to minimize potential for fin damage.
- Ensure cleaner thoroughly penetrates deep into finned areas.
- Interior and exterior finned areas must be thoroughly cleaned.
- Finned surfaces should remain wet with cleaning solution for 10 minutes.
- Ensure surfaces are not allowed to dry before rinsing. Reapply cleaner as needed to ensure 10-minute saturation is achieved.

- Thoroughly rinse all surfaces with low velocity clean water using downward rinsing motion of water spray nozzle. Protect fins from damage from the spray nozzle.

**⚠ CAUTION**

**Harsh Chemical and Acid Cleaners** — Harsh chemical, household bleach or acid cleaners should not be used to clean outdoor or indoors coils of any kind. These cleaners can be very difficult to rinse out of the coil and can accelerate corrosion at the fin/tube interface where dissimilar materials are in contact. If there is dirt below the surface of the coil, use the Environmentally Sound Coil Cleaner as described above.

**High Velocity Water or Compressed Air** — High velocity water from a pressure washer, garden hose or compressed air should never be used to clean a coil. The force of the water or air jet will bend the fin edges and increase airside pressure drop. Reduced unit performance or nuisance unit shutdown may occur.

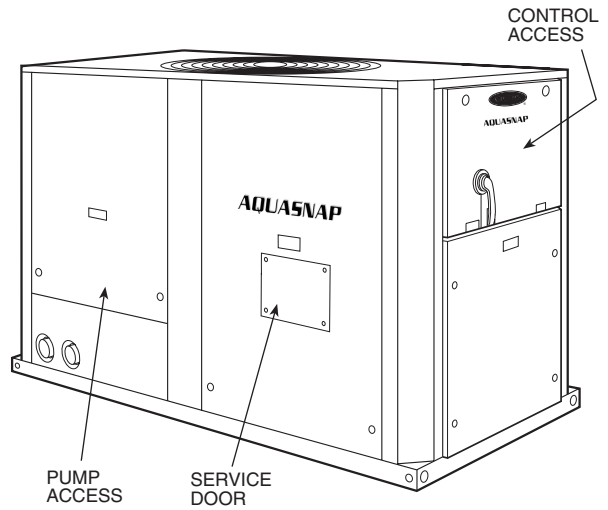

**Fig. 31 — 30RA Access Panels**

**CONDENSER SECTION** — Condenser fan motors and fans can be serviced by removal of outlet grilles or side panels. See Fig. 31. Be sure the wire fan guard is in place over each fan before starting unit. See Fig. 32 and 33 for proper fan adjustment. Fan mounting system is designed for fan to drop all the way on the motor shaft to be correctly located in the orifice. Tighten fan hub securely on motor shaft with setscrews which bear against the key. Be sure to replace the plastic fan cap and secure in place with the four locking clips to keep water and debris out of shaft area.

**Check Refrigerant Feed Components**

**THERMOSTATIC EXPANSION VALVE (TXV)** — The TXV controls the flow of liquid refrigerant to the cooler by maintaining constant superheat of vapor leaving the cooler. There is one valve per refrigerant circuit. The valve(s) is activated by a temperature-sensing bulb(s) strapped to the suction line(s). For proper TXV sensing bulb location, see Fig. 34.

The valve is factory-set to maintain between 8 and 12 F (4.4 and 6.7 C) of superheat entering the compressor(s). Elevate head pressure to 280 psig (1930 kPa) by blocking the airflow through the condenser. Check the superheat during operation after conditions have stabilized. A factory-installed temperature well is in each suction line for this purpose. If necessary, adjust the superheat to prevent refrigerant floodback to the compressor. Adjust TXVs 1/2 turn at a time, allowing the circuit to stabilize between adjustments. Turn stem counter-clockwise to decrease superheat and clockwise to increase superheat.

**FILTER DRIER** — The function of the filter drier is to maintain a clean, dry system. The moisture indicator (described below) indicates any need to change the filter drier. The filter drier is a sealed-type drier. When the drier needs to be changed, the entire filter drier must be replaced.

**NOTE:** Dual circuit (032-055 sizes) units have 1 filter drier per circuit.

**MOISTURE-LIQUID INDICATOR** — The indicator is located immediately ahead of the TXV to provide an indication of the refrigerant moisture content. It also provides a sight glass for refrigerant liquid. Clear flow of liquid refrigerant (*at full unit loading*) indicates sufficient charge in the system. Bubbles in the sight glass (*at full unit loading*) indicate an undercharged system or the presence of noncondensables. Moisture in the system, measured in parts per million (ppm), changes the color of the indicator as follows:

- Green (safe) — Moisture is below 45 ppm
- Yellow-Green (caution) — 45 to 130 ppm
- Yellow (wet) — above 130 ppm

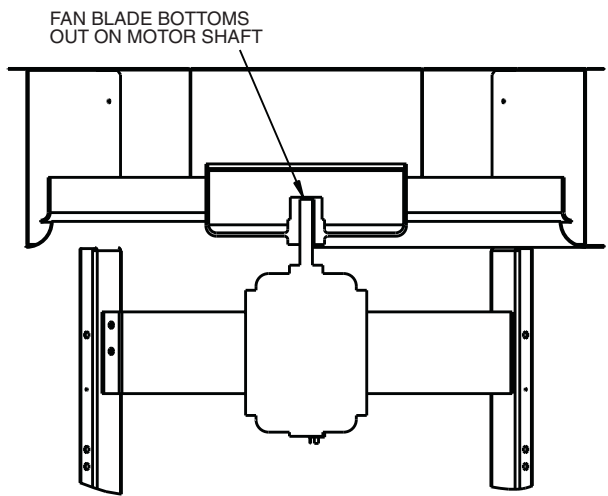

**Fig. 32 — Condenser-Fan Mounting**

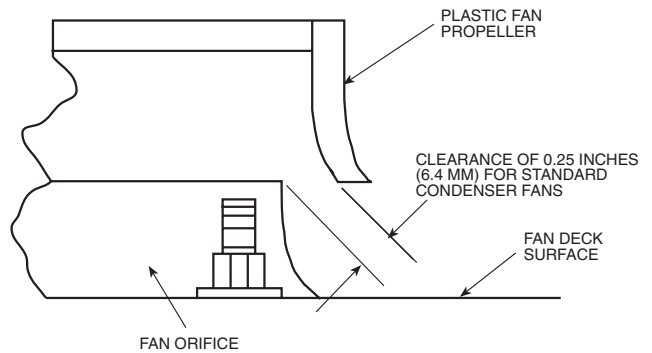
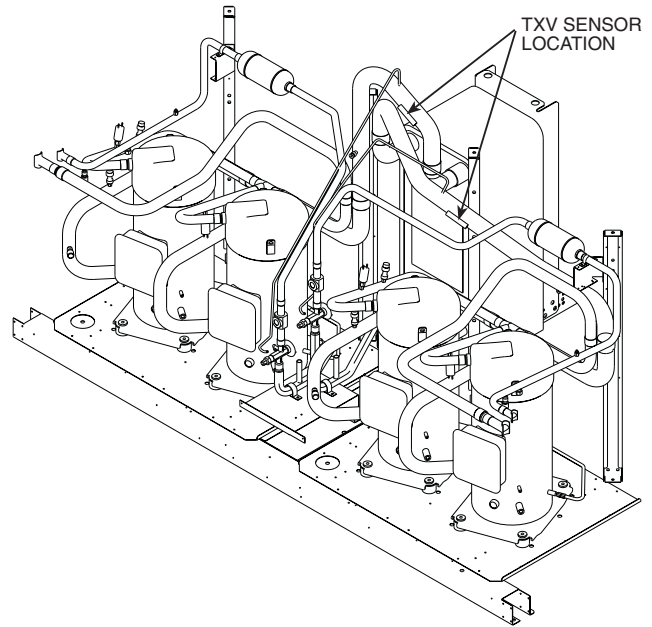
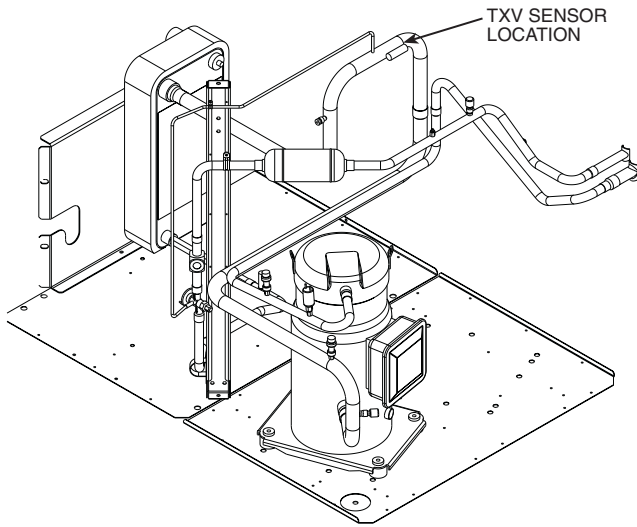

**Fig. 33 — Condenser-Fan Position (Standard Fan)**

The unit must be in operation at least 12 hours before the moisture indicator gives an accurate reading, and must be in contact with *liquid* refrigerant. At the first sign of moisture in the system, change the corresponding filter drier.

**NOTE:** Dual circuit (032-055 sizes) units have one indicator per circuit.

**MINIMUM LOAD VALVE** — On units equipped with the factory-installed capacity reduction option, a solenoid valve (minimum load valve) is located between the discharge line and the cooler entering-refrigerant line. The MBB cycles the solenoid to perform minimum load valve function.



**Fig. 34 — Mounting Locations for TXV Sensing Bulb**

The amount of capacity reduction achieved by the minimum load valve is not adjustable. The total unit capacity with the minimum load valve is shown in Table 7.

**PRESSURE RELIEF DEVICES** — All units have one pressure relief device per circuit located in the liquid line which relieves at 210 F (100 C).

**Compressor and Unit Protective Devices**

**MANUAL STARTER** — There is one manual starter per compressor in each unit. It protects the compressor(s) against overloading, locked rotor conditions, and primary single phasing. If the manual starter trips, determine the cause and correct it before resetting.

Manual starters are factory set; field adjustment should not be required. Manual starters are also factory installed for each condenser fan motor and factory-installed chilled water pump.

**NOTE:** Two-speed condenser fan motors on sizes 010-018 and 032-040 have manual starters so that the motor is protected while running in both low and high speed modes. Refer to Appendix B for factory settings.

**COMPRESSOR INTERNAL THERMAL PROTECTION** — All models include internal compressor protection. Models using the SM110 compressor (015 50 Hz and 018 60 Hz) have internal line break overloads. All other compressor models have internal discharge temperature thermostats that are wired in series with the compressor high pressure switch in the compressor motor junction box. The thermostat opens and shuts off the compressor if the discharge gas temperature exceeds 275 F (135 C). The thermostat will automatically reset when the temperature drops below a preset level, however, the control module will keep the unit locked off until the alert condition is reset.

**Check Unit Safeties**

**HIGH-PRESSURE SWITCH** — A high-pressure switch is provided to protect each compressor and refrigeration system from unsafe high pressure conditions. See Table 32 for high-pressure switch settings.

The high-pressure switch is mounted in the discharge side of each compressor. A snubber is provided between the compressor discharge manifold and the high-pressure switch to prevent pressure pulsations from damaging the switch.

The high-pressure switch is mounted in the discharge line of each compressor. If an unsafe, high-pressure condition should exist, the switch opens and shuts off the affected compressor. The compressor feedback signal to J9 of the MBB then opens causing an alert condition. The MBB prevents the compressor from restarting until the alert condition is reset. The switch should open at the pressure corresponding to the appropriate switch setting as shown in Table 32.

**Table 32 — Factory Settings, High-Pressure Switch (Fixed)**

UNIT	CUTOUT		CUT-IN	
	Psig	kPa	Psig	kPa
30RA	426 ± 7	2937 ± 48	324 ± 20	2206 ± 138

Clear the alarm using the Scrolling Marquee display as described on page 42. The unit should restart after the compressor anti-short-cycle delay, built into the unit control module, expires.

**PRESSURE TRANSDUCERS** — Each refrigerant circuit is equipped with a suction and discharge pressure transducer. The transducers are NOT the same part number. The discharge pressure transducer is the universal pressure transducer while the suction pressure transducer is a discrete low pressure transducer. These inputs to the MBB are not only used to monitor the status of the unit, but to also maintain operation of the chiller within the compressor manufacturer's specified limits. The input to the MBB from the suction pressure transducer is also used to protect the compressor from operating at low pressure conditions. In some cases, the unit may not be able to run at full capacity. The control module will automatically reduce the capacity of a circuit as needed to maintain specified maximum/minimum operating pressures.

**▲ WARNING**

On medium temperature brine units, the brine must be properly mixed to prevent freezing at a temperature of at least 15 F (8.3 C) below the leaving-fluid temperature set point. Failure to provide the proper brine mixture is considered abuse and may void the Carrier warranty.

The Main Base Board (MBB) monitors leaving fluid temperature at all times. The MBB will rapidly remove stages of capacity as necessary to prevent freezing conditions due to the rapid loss of load or low cooler fluid flow.

When the cooler is exposed to lower ambient temperatures (34 F [1° C] or below), freeze-up protection is required using inhibited ethylene glycol.

**HEATER CABLE** — Optional factory-installed cooler and/or hydronic package heaters are cycled based on the input from the outside-air temperature sensor. These heaters, when installed, are designed to protect the cooler and/or hydronic package from freezing down to -20 F (-29 C). Power for these heaters is supplied from the main unit power.

The input from the low pressure transducer provides a back-up cooler freeze protection package. The MBB shuts down the unit when a low pressure condition exists that could cause the cooler to freeze up.

**▲ CAUTION**

Do not disconnect main unit power when servicing compressor(s) if ambient temperature is below 40 F (4.4 C). Each compressor manual starter has a lockout feature. Depress the Stop Button and pull the lockout tab from the start button. Secure lock in place. If power to the unit must be off for a prolonged period, drain the cooler, hydronic package (if installed) and internal piping. Add glycol according to WINTER SHUTDOWN Step 2 below.

**WINTER SHUTDOWN** — At the end of the cooling season:

1. Drain the water/brine from the cooler, hydronic package (if installed) and internal piping.
2. Fill the package with at least 2 gallons (7.6 L) of ethylene glycol or other suitable uninhibited antifreeze solution to prevent any residual water in the cooler and hydronic package/piping from freezing.
3. At the beginning of the next cooling season, refill the cooler and add the recommended inhibitor.

**Thermistors** — Electronic control uses up to five 5 kΩ thermistors to sense temperatures used to control operation of the chiller. Thermistors T1, T2 and T9 are identical in their temperature and voltage drop performance. Accessory return gas thermistors are also 5 kΩ thermistors used to troubleshoot TXV superheat settings. Thermistor T10 has a 10 kΩ input channel and has a different set of temperature vs. resistance and voltage drop performance. Resistance at various temperatures are listed in Tables 33-36.

**NOTE:** For dual chiller operation, the control automatically configures the T10 input channel to be a 5 kΩ channel. A HH79NZ014 or HH79NZ029 thermistor should be used for dual chiller configurations.

Thermistor pin connection points are shown in Table 2. Thermistor T1 is located in a well at the bottom of the brazed plate heat exchanger for sizes 010-030 and in the leaving fluid piping for sizes 032-055.

Thermistor T2 is located in a well at the top of the brazed plate heat exchanger for sizes 010-030 and in the entering fluid piping for sizes 032-055. Thermistor T9 is factory installed in

the compressor section behind a panel with a vent plug so that outside air flows across the sensor tip.

**REPLACING THERMISTORS T1 and T2** — Add a small amount of thermal conductive grease to the thermistor well and end of probe. Thermistors are friction-fit thermistors, which must be slipped into receivers in the cooler (010-030) or fluid piping (032-055). For sizes 032-055, tighten the retaining nut ¼ turn past finger tight. See Fig. 35.

**THERMISTOR/TEMPERATURE SENSOR CHECK** — A high quality digital volt-ohmmeter is required to perform this check.

1. Connect the digital voltmeter across the appropriate thermistor terminals at the J8 terminal strip on the Main Base Board (see Fig. 36).
2. Using the voltage reading obtained, read the sensor temperature from Tables 33-36.
3. To check thermistor accuracy, measure temperature at probe location with an accurate thermocouple-type temperature measuring instrument. Insulate thermocouple to avoid ambient temperatures from influencing reading. Temperature measured by thermocouple and temperature determined from thermistor voltage reading should be close,  $\pm 5^\circ\text{F}$  ( $3^\circ\text{C}$ ) if care was taken in applying thermocouple and taking readings.

If a more accurate check is required, unit must be shut down and thermistor removed and checked at a known temperature (freezing point or boiling point of water) using either voltage drop measured across thermistor at the J8 terminal, by determining the resistance with chiller shut down and thermistor disconnected from J8. Compare the values determined with the value read by the control in the Temperatures mode using the Scrolling Marquee display.

**Pressure Transducers** — Suction and discharge pressure transducers are installed on each circuit. No pressure transducer calibration is required. The transducers operate on a 5 vdc supply, which is generated by the Main Base Board (MBB). See Fig. 36 for transducer connections to the J8 connector on the MBB.

**TROUBLESHOOTING** — If a transducer is suspected of being faulty, first check the supply voltage to transducer. Supply voltage should be 5 vdc  $\pm 0.2$  v. If supply voltage is correct, compare pressure reading displayed on the Scrolling Marquee display module against pressure shown on a calibrated pressure gauge. Suction pressure should be within  $\pm 2$  psig. Discharge pressure should be within  $\pm 5$  psig. If the two readings are not reasonably close, replace the pressure transducer.

**Flow Sensor** — A flow switch is factory installed in the leaving fluid piping of all models. If the unit is equipped with an optional hydronic system, the flow switch is inside the pump cabinet. If nuisance trips of the sensor are occurring, follow the steps below to correct the situation:

1. Check to confirm that the factory installed strainer is clean. Use the blow-down valve provided or remove the screen and clean it. For the case of VFD controlled pumps, ensure that the minimum speed setting has not been changed.
2. Measure the pressure drop across the cooler or cooler/pump system and compare this to the system requirements.
3. Verify that cable connections at the switch and at the terminal block are secure.
4. For factory-installed hydronic systems, verify that:
  - All air has been purged from the system
  - Circuit setter balance valve has been correctly set
5. Pump impeller has been improperly trimmed and is not providing sufficient flow.
6. Wrong pump motor rotation. Pump must rotate clockwise when viewed from motor end of pump.

**Table 33 — 5K Thermistor Temperatures (°F) vs. Resistance/Voltage Drop  
(Voltage Drop for Entering, Leaving Water and Outside-Air Thermistors T1, T2, T9)**

TEMP (F)	VOLTAGE DROP (V)	RESISTANCE (Ohms)	TEMP (F)	VOLTAGE DROP (V)	RESISTANCE (Ohms)	TEMP (F)	VOLTAGE DROP (V)	RESISTANCE (Ohms)
-25	3.699	98,010	59	1.982	7,686	143	0.511	1,190
-24	3.689	94,707	60	1.956	7,665	144	0.502	1,165
-23	3.679	91,522	61	1.930	7,468	145	0.494	1,141
-22	3.668	88,449	62	1.905	7,277	146	0.485	1,118
-21	3.658	85,486	63	1.879	7,091	147	0.477	1,095
-20	3.647	82,627	64	1.854	6,911	148	0.469	1,072
-19	3.636	79,871	65	1.829	6,735	149	0.461	1,050
-18	3.624	77,212	66	1.804	6,564	150	0.453	1,029
-17	3.613	74,648	67	1.779	6,399	151	0.445	1,007
-16	3.601	72,175	68	1.754	6,238	152	0.438	986
-15	3.588	69,790	69	1.729	6,081	153	0.430	965
-14	3.576	67,490	70	1.705	5,929	154	0.423	945
-13	3.563	65,272	71	1.681	5,781	155	0.416	925
-12	3.550	63,133	72	1.656	5,637	156	0.408	906
-11	3.536	61,070	73	1.632	5,497	157	0.402	887
-10	3.523	59,081	74	1.609	5,361	158	0.395	868
-9	3.509	57,162	75	1.585	5,229	159	0.388	850
-8	3.494	55,311	76	1.562	5,101	160	0.381	832
-7	3.480	53,526	77	1.538	4,976	161	0.375	815
-6	3.465	51,804	78	1.516	4,855	162	0.369	798
-5	3.450	50,143	79	1.493	4,737	163	0.362	782
-4	3.434	48,541	80	1.470	4,622	164	0.356	765
-3	3.418	46,996	81	1.448	4,511	165	0.350	750
-2	3.402	45,505	82	1.426	4,403	166	0.344	734
-1	3.386	44,066	83	1.404	4,298	167	0.339	719
0	3.369	42,679	84	1.382	4,196	168	0.333	705
1	3.352	41,339	85	1.361	4,096	169	0.327	690
2	3.335	40,047	86	1.340	4,000	170	0.322	677
3	3.317	38,800	87	1.319	3,906	171	0.317	663
4	3.299	37,596	88	1.298	3,814	172	0.311	650
5	3.281	36,435	89	1.278	3,726	173	0.306	638
6	3.262	35,313	90	1.257	3,640	174	0.301	626
7	3.243	34,231	91	1.237	3,556	175	0.296	614
8	3.224	33,185	92	1.217	3,474	176	0.291	602
9	3.205	32,176	93	1.198	3,395	177	0.286	591
10	3.185	31,202	94	1.179	3,318	178	0.282	581
11	3.165	30,260	95	1.160	3,243	179	0.277	570
12	3.145	29,351	96	1.141	3,170	180	0.272	561
13	3.124	28,473	97	1.122	3,099	181	0.268	551
14	3.103	27,624	98	1.104	3,031	182	0.264	542
15	3.082	26,804	99	1.086	2,964	183	0.259	533
16	3.060	26,011	100	1.068	2,898	184	0.255	524
17	3.038	25,245	101	1.051	2,835	185	0.251	516
18	3.016	24,505	102	1.033	2,773	186	0.247	508
19	2.994	23,789	103	1.016	2,713	187	0.243	501
20	2.972	23,096	104	0.999	2,655	188	0.239	494
21	2.949	22,427	105	0.983	2,597	189	0.235	487
22	2.926	21,779	106	0.966	2,542	190	0.231	480
23	2.903	21,153	107	0.950	2,488	191	0.228	473
24	2.879	20,547	108	0.934	2,436	192	0.224	467
25	2.856	19,960	109	0.918	2,385	193	0.220	461
26	2.832	19,393	110	0.903	2,335	194	0.217	456
27	2.808	18,843	111	0.888	2,286	195	0.213	450
28	2.784	18,311	112	0.873	2,239	196	0.210	445
29	2.759	17,796	113	0.858	2,192	197	0.206	439
30	2.735	17,297	114	0.843	2,147	198	0.203	434
31	2.710	16,814	115	0.829	2,103	199	0.200	429
32	2.685	16,346	116	0.815	2,060	200	0.197	424
33	2.660	15,892	117	0.801	2,018	201	0.194	419
34	2.634	15,453	118	0.787	1,977	202	0.191	415
35	2.609	15,027	119	0.774	1,937	203	0.188	410
36	2.583	14,614	120	0.761	1,898	204	0.185	405
37	2.558	14,214	121	0.748	1,860	205	0.182	401
38	2.532	13,826	122	0.735	1,822	206	0.179	396
39	2.506	13,449	123	0.723	1,786	207	0.176	391
40	2.480	13,084	124	0.710	1,750	208	0.173	386
41	2.454	12,730	125	0.698	1,715	209	0.171	382
42	2.428	12,387	126	0.686	1,680	210	0.168	377
43	2.402	12,053	127	0.674	1,647	211	0.165	372
44	2.376	11,730	128	0.663	1,614	212	0.163	367
45	2.349	11,416	129	0.651	1,582	213	0.160	361
46	2.323	11,112	130	0.640	1,550	214	0.158	356
47	2.296	10,816	131	0.629	1,519	215	0.155	350
48	2.270	10,529	132	0.618	1,489	216	0.153	344
49	2.244	10,250	133	0.608	1,459	217	0.151	338
50	2.217	9,979	134	0.597	1,430	218	0.148	332
51	2.191	9,717	135	0.587	1,401	219	0.146	325
52	2.165	9,461	136	0.577	1,373	220	0.144	318
53	2.138	9,213	137	0.567	1,345	221	0.142	311
54	2.112	8,973	138	0.557	1,318	222	0.140	304
55	2.086	8,739	139	0.548	1,291	223	0.138	297
56	2.060	8,511	140	0.538	1,265	224	0.135	289
57	2.034	8,291	141	0.529	1,240	225	0.133	282
58	2.008	8,076	142	0.520	1,214			

**Table 34 — 5K Thermistor Temperatures (°C) vs. Resistance/Voltage Drop  
(Voltage Drop for Entering, Leaving Water and Outside-Air Thermistors T1, T2, T9)**

TEMP (C)	VOLTAGE DROP (V)	RESISTANCE (Ohms)	TEMP (C)	VOLTAGE DROP (V)	RESISTANCE (Ohms)	TEMP (C)	VOLTAGE DROP (V)	RESISTANCE (Ohms)
-32	3.705	100,260	15	1.982	7,855	62	0.506	1,158
-31	3.687	94,165	16	1.935	7,499	63	0.490	1,118
-30	3.668	88,480	17	1.889	7,161	64	0.475	1,079
-29	3.649	83,170	18	1.844	6,840	65	0.461	1,041
-28	3.629	78,125	19	1.799	6,536	66	0.447	1,006
-27	3.608	73,580	20	1.754	6,246	67	0.433	971
-26	3.586	69,250	21	1.710	5,971	68	0.420	938
-25	3.563	65,205	22	1.666	5,710	69	0.407	906
-24	3.539	61,420	23	1.623	5,461	70	0.395	876
-23	3.514	57,875	24	1.580	5,225	71	0.383	836
-22	3.489	54,555	25	1.538	5,000	72	0.371	805
-21	3.462	51,450	26	1.497	4,786	73	0.360	775
-20	3.434	48,536	27	1.457	4,583	74	0.349	747
-19	3.406	45,807	28	1.417	4,389	75	0.339	719
-18	3.376	43,247	29	1.378	4,204	76	0.329	693
-17	3.345	40,845	30	1.340	4,028	77	0.319	669
-16	3.313	38,592	31	1.302	3,861	78	0.309	645
-15	3.281	38,476	32	1.265	3,701	79	0.300	623
-14	3.247	34,489	33	1.229	3,549	80	0.291	602
-13	3.212	32,621	34	1.194	3,404	81	0.283	583
-12	3.177	30,866	35	1.160	3,266	82	0.274	564
-11	3.140	29,216	36	1.126	3,134	83	0.266	547
-10	3.103	27,633	37	1.093	3,008	84	0.258	531
-9	3.065	26,202	38	1.061	2,888	85	0.251	516
-8	3.025	24,827	39	1.030	2,773	86	0.244	502
-7	2.985	23,532	40	0.999	2,663	87	0.237	489
-6	2.945	22,313	41	0.969	2,559	88	0.230	477
-5	2.903	21,163	42	0.940	2,459	89	0.223	466
-4	2.860	20,079	43	0.912	2,363	90	0.217	456
-3	2.817	19,058	44	0.885	2,272	91	0.211	446
-2	2.774	18,094	45	0.858	2,184	92	0.204	436
-1	2.730	17,184	46	0.832	2,101	93	0.199	427
0	2.685	16,325	47	0.807	2,021	94	0.193	419
1	2.639	15,515	48	0.782	1,944	95	0.188	410
2	2.593	14,749	49	0.758	1,871	96	0.182	402
3	2.547	14,026	50	0.735	1,801	97	0.177	393
4	2.500	13,342	51	0.713	1,734	98	0.172	385
5	2.454	12,696	52	0.691	1,670	99	0.168	376
6	2.407	12,085	53	0.669	1,609	100	0.163	367
7	2.360	11,506	54	0.649	1,550	101	0.158	357
8	2.312	10,959	55	0.629	1,493	102	0.154	346
9	2.265	10,441	56	0.610	1,439	103	0.150	335
10	2.217	9,949	57	0.591	1,387	104	0.146	324
11	2.170	9,485	58	0.573	1,337	105	0.142	312
12	2.123	9,044	59	0.555	1,290	106	0.138	299
13	2.076	8,627	60	0.538	1,244	107	0.134	285
14	2.029	8,231	61	0.522	1,200			

**Table 35 — 10K Thermistor Temperature (°F) vs. Resistance/Voltage Drop  
(For Thermistor T10)**

TEMP (F)	VOLTAGE DROP (V)	RESISTANCE (Ohms)	TEMP (F)	VOLTAGE DROP (V)	RESISTANCE (Ohms)	TEMP (F)	VOLTAGE DROP (V)	RESISTANCE (Ohms)
-25	4.758	196,453	61	2.994	14,925	147	0.890	2,166
-24	4.750	189,692	62	2.963	14,549	148	0.876	2,124
-23	4.741	183,300	63	2.932	14,180	149	0.862	2,083
-22	4.733	177,000	64	2.901	13,824	150	0.848	2,043
-21	4.724	171,079	65	2.870	13,478	151	0.835	2,003
-20	4.715	165,238	66	2.839	13,139	152	0.821	1,966
-19	4.705	159,717	67	2.808	12,814	153	0.808	1,928
-18	4.696	154,344	68	2.777	12,493	154	0.795	1,891
-17	4.686	149,194	69	2.746	12,187	155	0.782	1,855
-16	4.676	144,250	70	2.715	11,884	156	0.770	1,820
-15	4.665	139,443	71	2.684	11,593	157	0.758	1,786
-14	4.655	134,891	72	2.653	11,308	158	0.745	1,752
-13	4.644	130,402	73	2.622	11,031	159	0.733	1,719
-12	4.633	126,183	74	2.592	10,764	160	0.722	1,687
-11	4.621	122,018	75	2.561	10,501	161	0.710	1,656
-10	4.609	118,076	76	2.530	10,249	162	0.699	1,625
-9	4.597	114,236	77	2.500	10,000	163	0.687	1,594
-8	4.585	110,549	78	2.470	9,762	164	0.676	1,565
-7	4.572	107,006	79	2.439	9,526	165	0.666	1,536
-6	4.560	103,558	80	2.409	9,300	166	0.655	1,508
-5	4.546	100,287	81	2.379	9,078	167	0.645	1,480
-4	4.533	97,060	82	2.349	8,862	168	0.634	1,453
-3	4.519	94,020	83	2.319	8,653	169	0.624	1,426
-2	4.505	91,019	84	2.290	8,448	170	0.614	1,400
-1	4.490	88,171	85	2.260	8,251	171	0.604	1,375
0	4.476	85,396	86	2.231	8,056	172	0.595	1,350
1	4.461	82,729	87	2.202	7,869	173	0.585	1,326
2	4.445	80,162	88	2.173	7,685	174	0.576	1,302
3	4.429	77,662	89	2.144	7,507	175	0.567	1,278
4	4.413	75,286	90	2.115	7,333	176	0.558	1,255
5	4.397	72,940	91	2.087	7,165	177	0.549	1,233
6	4.380	70,727	92	2.059	6,999	178	0.540	1,211
7	4.363	68,542	93	2.030	6,838	179	0.532	1,190
8	4.346	66,465	94	2.003	6,683	180	0.523	1,169
9	4.328	64,439	95	1.975	6,530	181	0.515	1,148
10	4.310	62,491	96	1.948	6,383	182	0.507	1,128
11	4.292	60,612	97	1.921	6,238	183	0.499	1,108
12	4.273	58,781	98	1.894	6,098	184	0.491	1,089
13	4.254	57,039	99	1.867	5,961	185	0.483	1,070
14	4.235	55,319	100	1.841	5,827	186	0.476	1,052
15	4.215	53,693	101	1.815	5,698	187	0.468	1,033
16	4.195	52,086	102	1.789	5,571	188	0.461	1,016
17	4.174	50,557	103	1.763	5,449	189	0.454	998
18	4.153	49,065	104	1.738	5,327	190	0.447	981
19	4.132	47,627	105	1.713	5,210	191	0.440	964
20	4.111	46,240	106	1.688	5,095	192	0.433	947
21	4.089	44,888	107	1.663	4,984	193	0.426	931
22	4.067	43,598	108	1.639	4,876	194	0.419	915
23	4.044	42,324	109	1.615	4,769	195	0.413	900
24	4.021	41,118	110	1.591	4,666	196	0.407	885
25	3.998	39,926	111	1.567	4,564	197	0.400	870
26	3.975	38,790	112	1.544	4,467	198	0.394	855
27	3.951	37,681	113	1.521	4,370	199	0.388	841
28	3.927	36,610	114	1.498	4,277	200	0.382	827
29	3.903	35,577	115	1.475	4,185	201	0.376	814
30	3.878	34,569	116	1.453	4,096	202	0.370	800
31	3.853	33,606	117	1.431	4,008	203	0.365	787
32	3.828	32,654	118	1.409	3,923	204	0.359	774
33	3.802	31,752	119	1.387	3,840	205	0.354	762
34	3.776	30,860	120	1.366	3,759	206	0.349	749
35	3.750	30,009	121	1.345	3,681	207	0.343	737
36	3.723	29,177	122	1.324	3,603	208	0.338	725
37	3.697	28,373	123	1.304	3,529	209	0.333	714
38	3.670	27,597	124	1.284	3,455	210	0.328	702
39	3.654	26,838	125	1.264	3,383	211	0.323	691
40	3.615	26,113	126	1.244	3,313	212	0.318	680
41	3.587	25,396	127	1.225	3,244	213	0.314	670
42	3.559	24,715	128	1.206	3,178	214	0.309	659
43	3.531	24,042	129	1.187	3,112	215	0.305	649
44	3.503	23,399	130	1.168	3,049	216	0.300	639
45	3.474	22,770	131	1.150	2,986	217	0.296	629
46	3.445	22,161	132	1.132	2,926	218	0.292	620
47	3.416	21,573	133	1.114	2,866	219	0.288	610
48	3.387	20,998	134	1.096	2,809	220	0.284	601
49	3.357	20,447	135	1.079	2,752	221	0.279	592
50	3.328	19,903	136	1.062	2,697	222	0.275	583
51	3.298	19,386	137	1.045	2,643	223	0.272	574
52	3.268	18,874	138	1.028	2,590	224	0.268	566
53	3.238	18,384	139	1.012	2,539	225	0.264	557
54	3.208	17,904	140	0.996	2,488			
55	3.178	17,441	141	0.980	2,439			
56	3.147	16,991	142	0.965	2,391			
57	3.117	16,552	143	0.949	2,343			
58	3.086	16,131	144	0.934	2,297			
59	3.056	15,714	145	0.919	2,253			
60	3.025	15,317	146	0.905	2,209			

**Table 36 — 10K Thermistor Temperature (°C) vs. Resistance/Voltage Drop  
(For Thermistor T10)**

TEMP (C)	VOLTAGE DROP (V)	RESISTANCE (Ohms)	TEMP (C)	VOLTAGE DROP (V)	RESISTANCE (Ohms)	TEMP (C)	VOLTAGE DROP (V)	RESISTANCE (Ohms)
-32	4.762	200,510	15	3.056	15,714	62	0.940	2,315
-31	4.748	188,340	16	3.000	15,000	63	0.913	2,235
-30	4.733	177,000	17	2.944	14,323	64	0.887	2,157
-29	4.716	166,342	18	2.889	13,681	65	0.862	2,083
-28	4.700	156,404	19	2.833	13,071	66	0.837	2,011
-27	4.682	147,134	20	2.777	12,493	67	0.813	1,943
-26	4.663	138,482	21	2.721	11,942	68	0.790	1,876
-25	4.644	130,402	22	2.666	11,418	69	0.767	1,813
-24	4.624	122,807	23	2.610	10,921	70	0.745	1,752
-23	4.602	115,710	24	2.555	10,449	71	0.724	1,693
-22	4.580	109,075	25	2.500	10,000	72	0.703	1,637
-21	4.557	102,868	26	2.445	9,571	73	0.683	1,582
-20	4.533	97,060	27	2.391	9,164	74	0.663	1,530
-19	4.508	91,588	28	2.337	8,776	75	0.645	1,480
-18	4.482	86,463	29	2.284	8,407	76	0.626	1,431
-17	4.455	81,662	30	2.231	8,056	77	0.608	1,385
-16	4.426	77,162	31	2.178	7,720	78	0.591	1,340
-15	4.397	72,940	32	2.127	7,401	79	0.574	1,297
-14	4.367	68,957	33	2.075	7,096	80	0.558	1,255
-13	4.335	65,219	34	2.025	6,806	81	0.542	1,215
-12	4.303	61,711	35	1.975	6,530	82	0.527	1,177
-11	4.269	58,415	36	1.926	6,266	83	0.512	1,140
-10	4.235	55,319	37	1.878	6,014	84	0.497	1,104
-9	4.199	52,392	38	1.830	5,774	85	0.483	1,070
-8	4.162	49,640	39	1.784	5,546	86	0.470	1,037
-7	4.124	47,052	40	1.738	5,327	87	0.457	1,005
-6	4.085	44,617	41	1.692	5,117	88	0.444	974
-5	4.044	42,324	42	1.648	4,918	89	0.431	944
-4	4.003	40,153	43	1.605	4,727	90	0.419	915
-3	3.961	38,109	44	1.562	4,544	91	0.408	889
-2	3.917	36,182	45	1.521	4,370	92	0.396	861
-1	3.873	34,367	46	1.480	4,203	93	0.386	836
0	3.828	32,654	47	1.439	4,042	94	0.375	811
1	3.781	31,030	48	1.400	3,889	95	0.365	787
2	3.734	29,498	49	1.362	3,743	96	0.355	764
3	3.686	28,052	50	1.324	3,603	97	0.345	742
4	3.637	26,686	51	1.288	3,469	98	0.336	721
5	3.587	25,396	52	1.252	3,340	99	0.327	700
6	3.537	24,171	53	1.217	3,217	100	0.318	680
7	3.485	23,013	54	1.183	3,099	101	0.310	661
8	3.433	21,918	55	1.150	2,986	102	0.302	643
9	3.381	20,883	56	1.117	2,878	103	0.294	626
10	3.328	19,903	57	1.086	2,774	104	0.287	609
11	3.274	18,972	58	1.055	2,675	105	0.279	592
12	3.220	18,090	59	1.025	2,579	106	0.272	576
13	3.165	17,255	60	0.996	2,488	107	0.265	561
14	3.111	16,464	61	0.968	2,400			

**Strainer** — Periodic factory-installed strainer cleaning is required. Pressure drop across strainer in excess of 3 psi (21 kPa) indicates the need for cleaning. Normal (clean) pressure drop is approximately 1 psi (6.9 kPa). Open the factory-installed blowdown valve to clean the strainer. If required, shut the chiller down and remove the strainer screen to clean. When strainer has been cleaned, enter 'YES' for strainer maintenance done (S.T.MN) [Run Status, PM].

**Motormaster® V Controller** — The optional or accessory Motormaster V controller uses a 0 to 5 vdc signal input from a pressure transducer attached to the liquid line service valve gage port on each circuit. See Fig. 37. The pressure transducer is connected to terminals 2, 5 and 6 on the controller. The controller is factory configured and requires no field programming. If a situation arises where the drive does not function properly, the information provided below and Table 37 can be used to troubleshoot the drive.

**⚠ CAUTION**

If input power has not been applied to the drive for a period of time exceeding three years (due to storage, etc.), the electrolytic DC bus capacitors within the drive can change internally, resulting in excessive leakage current. This can result in premature failure of the capacitors if the drive is operated after such a long period of inactivity or storage. In order to reform the capacitors and prepare the drive for operation after a long period of inactivity, apply input power to the drive for 8 hours prior to actually operating the motor. Before attempting to operate the drive, motor, and driven equipment, be sure all procedures pertaining to installation and wiring have been properly followed.

**⚠ CAUTION**

DO NOT connect incoming AC power to output terminals T1, T2, and T3! Severe damage to the drive will result. Do not continuously cycle input power to the drive more than once every two minutes. Damage to the drive will result.

**⚠ WARNING**

Hazard of electrical shock! Wait three minutes after disconnecting incoming power before servicing drive. Capacitors retain charge after power is removed. Drive assembly includes externally mounted current limiting resistors. Use extreme caution when servicing the drive.

**⚠ WARNING**

When configured as shown below, this equipment is designed to start when it receives line power. Ensure that all personnel are clear of fans and guards are installed before applying power.

**GENERAL OPERATION** — This control varies condenser fan speed based on liquid pressure. The control is a Variable Frequency Drive (VFD) and is only compatible with motors rated for use with VFDs. The accompanying pressure transducer has a 0 to 5 v output range corresponding to a -40 to 460 psi range. The VFD provides a 5 v output for the transducer on pin 6.

This system is a reverse acting, proportional-integral (PI) control. The VFD will vary the motor speed to drive the liquid line pressure to the set point during ambient temperatures below 60 F. The set point is lower than a normal operating pressure during summer operation. At higher ambient temperatures, the fan will go to full speed (60 Hz or 50 Hz depending on model) and remain there since it can not go fast enough to

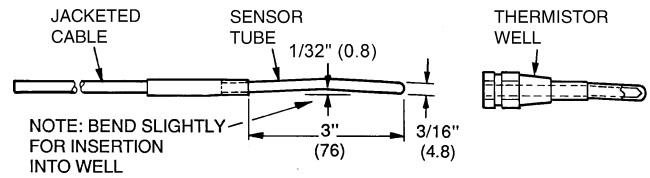

**FLUID-SIDE TEMPERATURE SENSORS (T1 AND T2)**  
NOTE: Dimensions in ( ) are in millimeters.

**Fig. 35 — Fluid-Side Temperature Sensors (T1 and T2)**

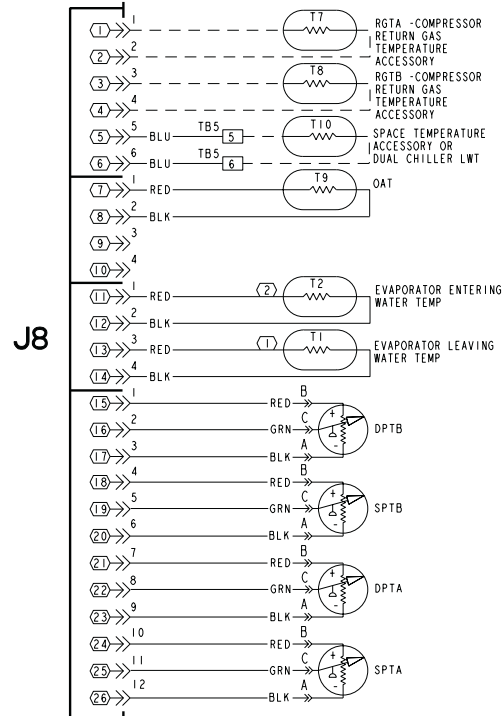

**Fig. 36 — Thermistor Connections to Main Base Board, J8 Connector**

bring the pressure down to the set point. When the VFD is at full speed, it acts just like a fixed speed fan.

When the ambient air temperature drops, a fan running at full speed draws too much air across the condenser coil to maintain a minimum condensing pressure/temperature. In these conditions, the VFD will slow down and begin to maintain a set point.

The VFD will display the set point as the default. The set point is displayed in speed as Hz and is configured by the start command jumper as detailed in Fig. 38.

Motormaster V control can also be configured to follow an external control system to perform the PI control functions. See configuration section for details.

The real-time feedback signal (liquid line pressure, in volts) is displayed by viewing parameter 69. The real-time output frequency is displayed by viewing parameter 71.

**SET POINTS** — Operating modes are configured for R-22 with a set point of 135 psig on the liquid line.

**INSTALLATION** — See Fig. 38 for transducer wiring to the VFD.

NOTE: The drive is phase insensitive with respect to incoming line voltage. This means that the VFD will operate with any phase sequence of the incoming three-phase voltage.

**▲ CAUTION**

It is strongly recommended that the user NOT change any programming without consulting Carrier service personnel. Unit damage may occur from improper programming.

Motormaster V control is completely configured according to the inputs provided. No additional programming is necessary.

The drive can display 71 program parameters. Parameters 50-60 are monitor functions and cannot be changed. The remainder of the parameters can be changed after entering a password.

To enter password and change program values:

1. Press **Mode**.
2. Upper right decimal point blinks.
3. Display reads "00" (see Fig. 37). To enter the PROGRAM mode to access the parameters, press the **Mode** button (see Fig. 37). This will activate the PASSWORD prompt (if the password has not been disabled). The display will read "00" and the upper right-hand decimal point will be blinking.
4. Use the ▲ and ▼ buttons to scroll to the password value (the factory default password is "111") and press the **Mode** button. Once the correct password value is entered, the display will read "P01", which indicates that the PROGRAM mode has been accessed at the beginning of the parameter menu (P01 is the first parameter).

**NOTE:** If the display flashes "Er", the password was incorrect, and the process to enter the password must be repeated.

5. Press **Mode** to display present parameter setting. Upper right decimal point blinks.  
Use the ▲ and ▼ buttons to scroll to the desired parameter number.

Once the desired parameter number is found, press the **Mode** button to display the present parameter setting. The upper right-hand decimal point will begin blinking, indicating that the present parameter setting is being displayed, and that it can be changed by using the up and down buttons. Use ▲ and ▼ to change setting. Press **Mode** to store new setting.

Pressing the **Mode** will store the new setting and also exit the PROGRAM mode. To change another parameter, press the **Mode** key again to re-enter the PROGRAM mode (the parameter menu will be accessed at the parameter that was last viewed or changed before exiting). If the **Mode** key is pressed within two minutes of exiting the PROGRAM mode, the password is not required access the parameters. After two minutes, the password must be entered in order to access the parameters again.

To change password: first enter the current password then change parameter P44 to the desired password.

To disable automatic control mode and enter manual speed control mode:

1. Change P05 to '01- keypad'.
2. Push UP and DOWN arrow key to set manual speed.
3. Set P05 to '05 - R22' to restore automatic control.

To provide manual start/stop control:

With power removed from VFD, remove start command jumper and install a switch between the appropriate start terminals as required in Fig 37.

**EPM CHIP** — The drive uses a electronic programming module (EPM) chip to store the program parameters. This is an EE-PROM memory chip and is accessible from the front of the VFD. It should not be removed with power applied to the VFD.

**LIQUID LINE PRESSURE SET POINT ADJUSTMENT** — Adjusting the set point is not recommended due to possible interaction with other head pressure software algorithms or controls. In situations where the set point must be changed, the set point for R-22 is found in P34. A higher value will result in a higher liquid line set point. Example: increasing the factory default (P34) set point from 18.0 to 19.0 will increase the liquid line pressure by approximately 10 psi.

**LOSS OF CCN COMMUNICATIONS** — Carrier Comfort Network (CCN) communications with external control systems can be affected by high frequency electrical noise generated by the Motormaster V control. Ensure unit is well grounded to eliminate ground currents along communication lines.

If communications are lost only while Motormaster V control is in operation, order a signal isolator (CEAS420876-2) and power supplies (CEAS221045-01, 2 required) for the CCN communication line.

**Fault Codes** — The drive is programmed to automatically restart after a fault and will attempt to restart three times after a fault (the drive will not restart after CF, cF, GF, F1, F2-F9, or Fo faults). If all three restart attempts are unsuccessful, the drive will trip into FAULT LOCKOUT (LC), which requires a manual reset.

**NOTE:** Since faults may be reset as incoming power is cycled, you may need to observe current fault code before the Carrier unit control turns off the VFD. Most recent faults can be accessed using parameter 50. If necessary, remove start jumper and energize condenser fan contactor using Service Test. This will allow programming and access to fault history.

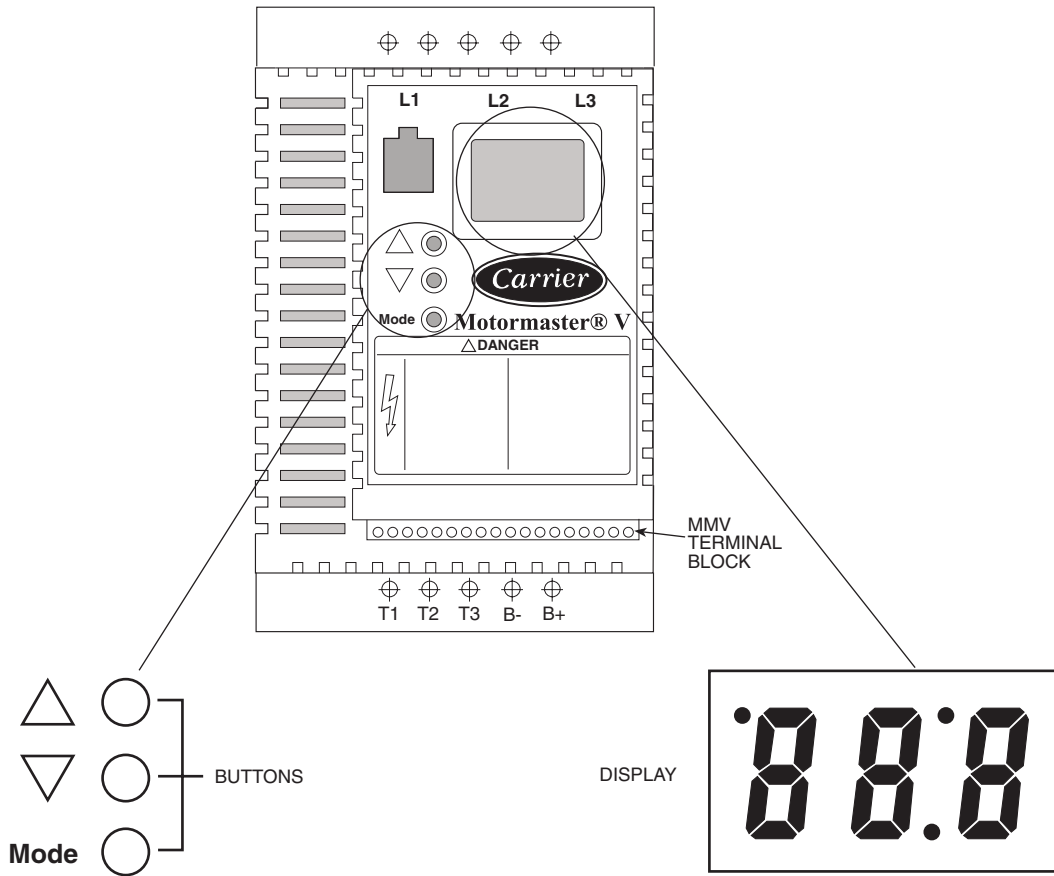

**Fig. 37 — Motormaster® V Mode Buttons and Mode Display**

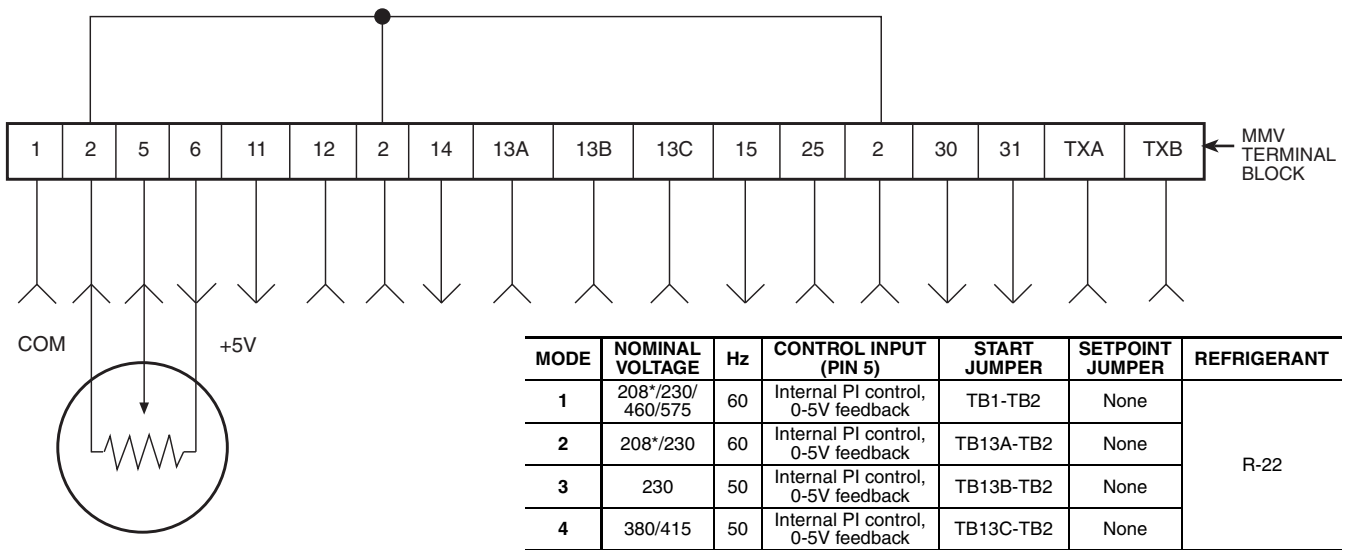

\*At 208 v, the drive can run in either mode.

**Fig. 38 — Pressure Transducer and Start Command Jumper Wiring**

**Table 37 — Fault Codes**

FAULT CODE	DESCRIPTION	SOLUTION
AF	High Temperature Fault: Ambient temperature is too high; Cooling fan has failed (if equipped).	Check cooling fan operation
CF	Control Fault: A blank EPM, or an EPM with corrupted data has been installed.	Perform a factory reset using Parameter 48 — PROGRAM SELECTION.
cF	Incompatibility Fault: An EPM with an incompatible parameter version has been installed.	Either remove the EPM or perform a factory reset (Parameter 48) to change the parameter version of the EPM to match the parameter version of the drive.
CL	CURRENT LIMIT: The output current has exceeded the CURRENT LIMIT setting (Parameter 25) and the drive is reducing the output frequency to reduce the output current. If the drive remains in CURRENT LIMIT too long, it can trip into a CURRENT OVERLOAD fault (PF).	Check for loose electrical connections. Check for faulty condenser fan motor. Check Parameter P25 from Table 38 is set correctly.
GF	Data Fault: User data and OEM defaults in the EPM are corrupted.	Restore factory defaults P48, see section above. If that does not work, replace EPM.
HF	High DC Bus Voltage Fault: Line voltage is too high; Deceleration rate is too fast; Overhauling load.	Check line voltage — set P01 appropriately
JF	Serial Fault: The watchdog timer has timed out, indicating that the serial link has been lost.	Check serial connection (computer) Check settings for PXX. Check settings in communication software to match PXX.
LF	Low DC Bus Voltage Fault: Line voltage is too low.	Check line voltage — set P01 appropriately
OF	Output Transistor Fault: Phase to phase or phase to ground short circuit on the output; Failed output transistor; Boost settings are too high; Acceleration rate is too fast.	Reduce boost or increase acceleration values. If unsuccessful, replace drive.
PF	Current Overload Fault: VFD is undersized for the application; Mechanical problem with the driven equipment.	Check line voltage — set P01 appropriately Check for dirty coils Check for motor bearing failure
SF	Single-phase Fault: Single-phase input power has been applied to a three-phase drive.	Check input power phasing
F1	EPM Fault: The EPM is missing or damaged.	
F2-F9, Fo	Internal Faults: The control board has sensed a problem	Consult factory
Drive display = 60.0 even though it is cold outside and it should be running slower	Feedback signal is above set point	Check for proper set point Check liquid line pressure
Drive display = '---' even though drive should be running	Start jumper is missing	Replace start jumper. See section above
Drive display = 8.0 even though fan should be running faster	Feedback signal is below set point and fan is at minimum speed	Check for proper set point Check liquid line pressure
VFD flashes 57 and LCS	Feedback or speed signal lost. Drive will operate at 57 Hz until reset or loss of start command. Resetting requires cycling start command (or power).	In stand alone mode: Check transducer wiring and feedback voltage. Feedback voltage displayed on P-69. Pin 6 should be 5 v output. Pin 5 (feedback) should be somewhere between 0 and 5 v.

**Manual Reset** — If fault condition has been removed, cycle power to the chiller to reset the VFD.

**Troubleshooting** — Troubleshooting the Motormaster® V control requires a combination of observing system operation and VFD information. The drive provides 2 kinds of troubleshooting modes: a status matrix using the 3-digit display (P57, P58) and real time monitoring of key inputs and outputs. The collective group is displayed through parameters 50-60 and all values are read-only.

- **P50: FAULT HISTORY** — Last 8 faults
- **P51: SOFTWARE version**
- **P52: DC BUS VOLTAGE** — in percent of nominal. Usually rated input voltage x 1.4
- **P53: MOTOR VOLTAGE** — in percent of rated output voltage

- **P54: LOAD** — in percent of drives rated output current rating
- **P55: VDC INPUT** — in percent of maximum input: 100 will indicate full scale which is 5 v
- **P56 4-20 mA INPUT** — in percent of maximum input. 20% = 4 mA, 100% = 20 mA

**Manual Starter Trip** — If the VFD manual starter (MS-FC-HS, MS-FC-A1 or MS-FC-B1 depending on model) trips, locate the inrush current protectors (3 round black disks per motor) and verify their resistance. For units operating at 208 v or 230 v, these devices should measure approximately 7 ohms. For all other voltages, they should measure approximately 20 ohms. Check value with mating plug disconnected, power to chiller off and at ambient temperature (not hot immediately after stopping VFD). These are standard resistances at 77 F (25 C). Resistance values decrease at higher temperatures and increase at lower temperatures.

**Table 38 — Motormaster® V Program Parameters for Operating Modes**

PARAMETERS	DESCRIPTION	MODE 1	MODE 2	MODE 3	MODE 4
P01	Line Voltage: 01 = low line, 02 = high line	01	02	01	02
P02	Carrier Freq: 01 = 4 kHz, 02 = 6 kHz, 03 = 8 kHz	01	01	01	01
P03	Startup mode: flying restart	06	06	06	06
P04	Stop mode: coast to stop	01	01	01	01
P05	Standard Speed source: 01= keypad, 04=4-20mA (NO PI), 05= R22, 06=R134a	05	05	05	05
P06	TB-14 output: 01 = none	01	01	01	01
P08	TB-30 output: 01 = none	01	01	01	01
P09	TB-31 Output: 01 = none	01	01	01	01
P10	TB-13A function sel: 01 = none	01	01	01	01
P11	TB-13B function sel: 01 = none	01	01	01	01
P12	TB-13C function sel: 01 = none	01	01	01	01
P13	TB-15 output: 01 = none	01	01	01	01
P14	Control: 01 = Terminal strip	01	01	01	01
P15	Serial link: 02 = enabled 9600,8,N,2 with timer	02	02	02	02
P16	Units editing: 02 = whole units	02	02	02	02
P17	Rotation: 01 = forward only, 03 = reverse only	01	01	01	01
P19	Acceleration time: 10 sec	10	10	10	10
P20	Deceleration time: 10 sec	10	10	10	10
P21	DC brake time: 0	0	0	0	0
P22	DC BRAKE VOLTAGE 0%	0	0	0	0
P23	Min freq = 8 Hz ~ 100 – 160 rpm	8	8	8	8
P24	Max freq	60	60	50	50
P25	Current limit: (%)	125	110	125	110
P26	Motor overload: 100	100	100	100	100
P27	Base freq: 60 or 50 Hz	60	60	50	50
P28	Fixed boost: 0.5% at low frequencies	0.5	0.5	0.5	0.5
P29	Accel boost: 0%	0	0	0	0
P30	Slip compensation: 0%	0	0	0	0
P31	Preset spd #1: speed if loss of control signal	57	57	47	47
P32	Preset spd #2: 0	0	0	0	0
P33	Preset spd #3: 0	0	0	0	0
P34	Preset spd 4 default — R22 set point. TB12-2 open	18.0	18.0	18.0	18.0
P35	Preset spd 5 default — R134a set point. TB12-2 closed	12.6	12.6	12.6	12.6
P36	Preset spd 6 default	0	0	0	0
P37	Preset spd 7 default	0	0	0	0
P38	Skip bandwidth	0	0	0	0
P39	Speed scaling	0	0	0	0
P40	Frequency scaling 50 or 60 Hz	60	60	50	50
P41	Load scaling: default (not used so NA)	200	200	200	200
P42	Accel/decel #2: default (not used so NA)	60	60	60	60
P43	Serial address	1	1	1	1
P44	Password:111	111	111	111	111
P45	Speed at min signal: 8 Hz: used when PID mode is disabled and 4-20mA input is at 4 mA	8	8	8	8
P46	Speed at max feedback: 60 or 50 Hz. Used when PID disabled and 4-20mA input is at 20 mA	60	60	50	50
P47	Clear history? 01 = maintain. (set to 02 to clear)	01	01	01	01
P48	Program selection: Program 1 – 12	01	02	03	04
P61	PI Mode: 05= reverse, 0-5V, 01 = no PID	05	05	05	05
P62	Min feedback = 0 (0V *10)	0	0	0	0
P63	Max feedback = 50 (5V * 10)	50	50	50	50
P64	Proportional gain = 4%	4	4	4	4
P65	Integral gain = .2	.2	.2	.2	.2
P66	PI accel/decel (set point change filter) = 5	5	5	5	5
P67	Min alarm	0	0	0	0
P68	Max alarm	0	0	0	0

LEGEND

- NA — Not Applicable
- PID — Proportional Integral Derivative
- TB — Terminal Block

**REPLACING DEFECTIVE MODULES** — The *Comfort-Link™* replacement modules are shown in Table 39. If the Main Base Board (MBB) has been replaced, verify that all configuration data is correct. Follow the Configuration mode table and verify that all items under sub-modes UNIT, OPT1 and OPT2 are correct. Any additional field-installed accessories or options (RSET, SLCT sub-modes) should also be verified as well as any specific time and maintenance schedules.

Refer to the Start-Up Checklist for 30RA Liquid Chillers (completed at time of original start-up) found in the job folder. This information is needed later in this procedure. If the checklist does not exist, fill out the current information in the Configuration mode on a new checklist. Tailor the various options and configurations as needed for this particular installation.

<b>⚠ CAUTION</b>
Electrical shock can cause personal injury. Disconnect all electrical power before servicing.

1. Check that all power to unit is off. Carefully disconnect all wires from the defective module by unplugging its connectors.
2. Remove the defective module by removing its mounting screws with a Phillips screwdriver, and removing the module from the control box. Save the screws later use.
3. Verify that the instance jumper (MBB) or address switches (all other modules) exactly match the settings of the defective module.

**NOTE:** Handle boards by mounting standoffs only to avoid electrostatic discharge.

4. Package the defective module in the carton of the new module for return to Carrier.
5. Mount the new module in the unit's control box using a Phillips screwdriver and the screws saved in Step 2.
6. Reinstall all module connectors. For accessory Navigator replacement, make sure the plug is installed at TB3 in the LEN connector.
7. Carefully check all wiring connections before restoring power.
8. Verify the ENABLE/OFF/REMOTE CONTACT switch is in the OFF position.
9. Restore control power. Verify that all module red LEDs blink in unison. Verify that all green LEDs are blinking and that the Scrolling Marquee or Navigator display is communicating correctly.
10. Verify all configuration information, settings, set points and schedules. Return the ENABLE/OFF/REMOTE CONTACT switch to its previous position.

**Table 39 — Replacement Modules**

MODULE	REPLACEMENT PART NO. (with Software)	REPLACEMENT PART NO. (without Software)
Main Base Board (MBB)	30RA501102	HK50AA029
Scrolling Marquee Display	HK50AA031	HK50AA030
Energy Management Module (EMM)	30GT515218	HK50AA028
Navigator Display	HK50AA033	N/A

**Hydronic Package** — If the unit is equipped with a factory-installed hydronic package, consult the information below for proper maintenance and service. In addition to this

information, each factory-installed hydronic package is supplied with a packet of information supplied by the manufacturer, Bell & Gossett. Carrier Corporation strongly recommends that this information be thoroughly reviewed prior to operation of the chiller.

**PUMP PERFORMANCE CHECK** — The factory-installed pumps in the 30RA units are shipped with a single impeller size available for that pump. The pump was selected based on the flow and head requirements as provided to Carrier. It is not uncommon for actual pump duty to be different than what was anticipated at time of selection. In many cases, it may be desirable to make some field modifications to obtain optimum pump performance.

Before any pump modifications are made, it is recommended that actual pump performance be verified and compared to the applicable pump curve. See base unit installation instructions. This can be done in a variety of ways:

1. If pump impeller diameter is known:
  - a. Connect a differential pressure gage across the pump at the ports provided on the pump volutes.
  - b. Read GPM from applicable impeller curve.

2. If pump impeller diameter is not known:

If pump impeller diameter has been trimmed and the size is not known, it is necessary to determine which impeller curve to read.

The easiest way to confirm pump performance is to “dead-head” the pump and read the differential pressure across the pressure ports on the pump. “Dead-heading” can be done by shutting the circuit setter valve on the discharge side of the pump.

**NOTE:** Although not all pumps can be safely “dead-headed”, centrifugal pumps (such as on the 30RA units) can be “dead-headed” for short amounts of time. It is recommended to keep the time short due to excessive heat build-up in the pump.

Since the “dead-head” condition is a no-flow condition, the head will correspond to the intersection of an impeller curve with the vertical axis of the pump chart. The correct impeller diameter is that which corresponds to the measured head.

3. Once the impeller diameter is known, proceed as in Step 1.
4. Water flow rate can be determined by using a differential pressure gage with the Bell & Gossett circuit setter balance valve calculator. (This information is also provided in the installation instructions.) This method will not directly measure pressure differential seen by the pump, but can be used to “double-check” the pump measurement.
5. Verify that cable connections at the switch and at the terminal block are secure.
6. For factory-installed hydronic system, verify that:
  - All air has been purged from the system.
  - Circuit setter balance valve has been correctly set.
7. Pump impeller has been improperly trimmed and is not providing sufficient flow.
8. Wrong pump motor rotation. Pump must rotate clockwise when viewed from motor end of pump.

**PUMP MODIFICATIONS AND IMPELLER TRIMMING** — See applicable section in the Installation instructions.

**RESET OF CHILLER WATER FLOW** — See applicable section in the Installation instructions.

**CHANGING OF PUMP SEALS** — See Bell & Gossett service instruction manual provided with the hydronic package.

## MAINTENANCE

**Recommended Maintenance Schedule** — The following are only recommended guidelines. Jobsite conditions may dictate that maintenance schedule is performed more often than recommended.

Routine:

For machines with E-coat Condenser Coils:

- Check condenser coils for debris, clean as necessary with Carrier approved coil cleaner.
- Periodic clean water rinse, especially in coastal and industrial applications.

Every month:

- Check condenser coils for debris, clean as necessary with Carrier approved coil cleaner.
- Check moisture indicating sight glass for possible refrigerant loss and presence of moisture.

Every 3 months (for all machines):

- Check refrigerant charge.
- Check all refrigerant joints and valves for refrigerant leaks, repair as necessary.
- Check chilled water flow switch operation.
- Check condenser coils for debris, clean as necessary with Carrier approved coil cleaner.
- Check all condenser fans for proper operation.
- Check compressor oil level.
- Check crankcase heater operation.

Every 12 months (for all machines):

- Check all electrical connections, tighten as necessary.
- Inspect all contactors and relays, replace as necessary.
- Check accuracy of thermistors, replace if greater than  $\pm 2^\circ\text{F}$  ( $1.2^\circ\text{C}$ ) variance from calibrated thermometer.
- Obtain and test an oil sample. Change oil only if necessary.
- Check to be sure that the proper concentration of anti-freeze is present in the chilled water loop, if applicable.
- Verify that the chilled water loop is properly treated.
- Check refrigerant filter driers for excessive pressure drop, replace as necessary.
- Check chilled water strainers, clean as necessary.
- Check cooler heater operation, if equipped.
- Check condition of condenser fan blades and that they are securely fastened to the motor shaft.
- Perform Service Test to confirm operation of all components.
- Check for excessive cooler approach (Leaving Chilled Water Temperature — Saturated Suction Temperature) which may indicate fouling. Clean cooler vessel if necessary.

## PRE-START-UP

**IMPORTANT:** Before beginning Pre-Start-Up or Start-Up, complete Start-Up Checklist for 30RA Liquid Chiller at end of this publication (page CL-1 to CL-8). The Checklist assures proper start-up of a unit, and provides a record of unit condition, application requirements, system information, and operation at initial start-up.

Do not attempt to start the chiller until following checks have been completed.

### System Check

1. Check all auxiliary components, such as chilled fluid pumps, air-handling equipment, or other equipment to which the chiller supplies liquid. Consult manufacturer's instructions. Verify that any pump interlock contacts have been properly installed. If the unit has

field-installed accessories, be sure all are properly installed and wired correctly. Refer to unit wiring diagrams.

2. Use the Scrolling Marquee display to adjust the Cooling Set Point.
3. Fill chilled fluid circuit with clean water (with recommended inhibitor added) or other non-corrosive fluid to be cooled. Bleed all air out of the high points of the system. If chilled water is to be maintained at a temperature below 40 F (4.4 C) or outdoor temperatures are expected to be below 32 F (0° C), a brine of sufficient concentration must be used to prevent freeze-up at anticipated suction temperatures. See Table 40.
4. Check tightness of all electrical connections.
5. Oil should be visible in the compressor sightglass(es). See Fig. 39. An acceptable oil level in the compressors is from  $\frac{1}{4}$  to  $\frac{3}{4}$  of sight glass. Adjust the oil level as required. See Check Oil Charge section on page 60 for Carrier approved oils.
6. Electrical power source must agree with unit nameplate.
7. All condenser fan and factory installed hydronic package pump motors are three phase. Check for proper rotation of condenser fans first BEFORE attempting to start pumps or compressors. To reverse rotation, interchange any two of the main incoming power leads.
8. Be sure system is fully charged with refrigerant (see Check Refrigerant Charge section on page 75).
9. If unit is a brine unit, check to ensure proper brine concentration is used to prevent freezing.
10. Verify proper operation of cooler and hydronic package heaters (if installed). Heaters operate at the same voltage as the main incoming power supply and are single phase. Heater current is approximately .4 amps for 380, 400, 460 and 575 v units. Heater current is approximately .8 amps for 230 v units.

**Table 40 — Minimum Cooler Flow Rates and Minimum Loop Volume**

UNIT SIZE 30RA	COOLER MINIMUM FLOW		MINIMUM COOLER LOOP VOLUME	
	Gpm	L/s	Gal.	L
010	12	.76	40	151.2
015	16	1.01	55	207.9
018	19	1.20	48	181.4
022	26	1.64	65	245.7
025	29	1.83	71	268.3
030	33	2.08	82	309.3
035	42	2.65	102	393.1
040	45	2.80	113	449.8
042	48	3.02	119	427.1
045	52	3.28	129	487.6
050	57	3.59	142	536.6
055	65	4.10	163	616.1

## START-UP AND OPERATION

NOTE: Refer to Start-Up Checklist on pages CL-1 to CL-8.

**Actual Start-Up** — Actual start-up should be done only under supervision of a qualified refrigeration mechanic.

1. Be sure all service valves are open.
2. Using the Scrolling Marquee display, set leaving-fluid set point (CSP.1) [Set Point, COOL]. No cooling range adjustment is necessary.
3. Start chilled fluid pump (if not configured for cooler pump control).
4. Turn ENABLE/OFF/REMOTE CONTACT switch to ENABLE position.

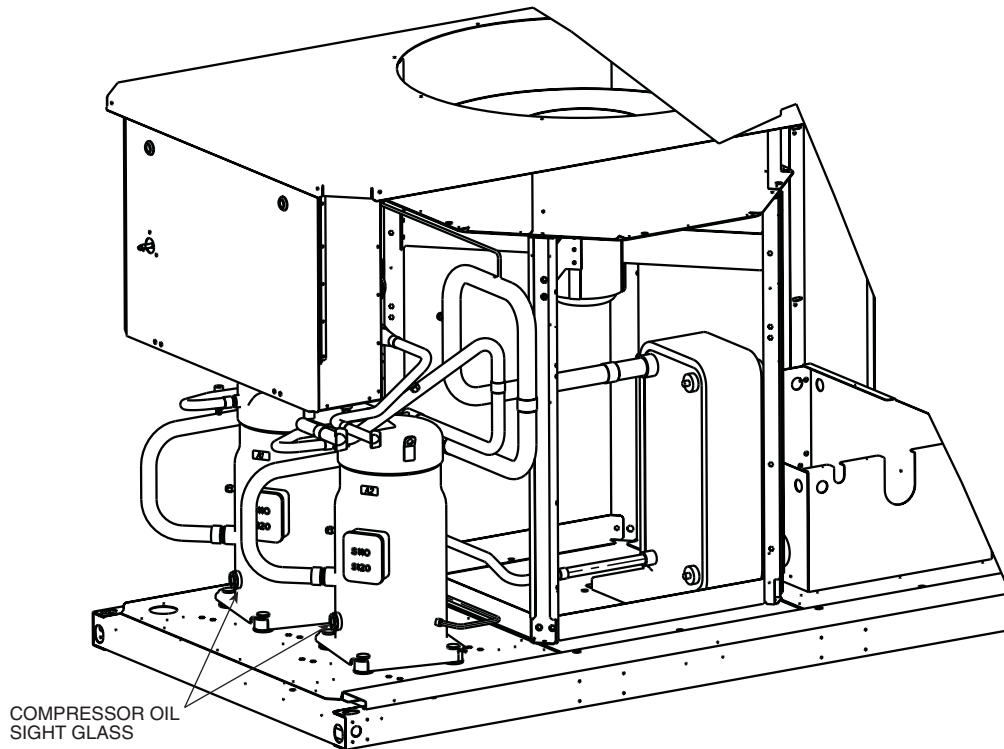

**Fig. 39 — Compressor Connections and Oil Sight Glass Location**

5. Allow unit to operate and confirm that everything is functioning properly. Check to see that leaving fluid temperature agrees with leaving set point (CSP.1 or CSP.2), or if reset is used, with the control point (CTPT) [Run Status, VIEW].
6. Check the cooler leaving chilled water temperature to see that it remains well above 32 F (0° C), or the brine freezing point if the unit is a medium temperature brine unit.
7. Recheck compressor oil level (see Check Oil Charge section).

**Check Refrigerant Charge** — All 30RA units are shipped with a complete operating charge of R-22 and should be under sufficient pressure to conduct a leak test after installation. If there is no system pressure, admit nitrogen until a pressure is observed and then proceed to test for leaks. After leaks are repaired, the system must be dehydrated.

All refrigerant charging should be done through the 1/4-in. Schraeder connection on the liquid line. Do NOT add refrigerant charge through the low-pressure side of the system. If complete charging is required, weigh in the appropriate charge for the circuit as shown on the unit nameplate. If partial charging is required, operate circuit at full load and use an accurate temperature sensor on the liquid line as it enters the TXV. Use the Temperatures mode on the Scrolling Marquee display to show the circuit saturated condensing temperature (SCT.A or SCT.B). Charging is most accurate at saturated discharge temperatures of 120 to 125 F (49 to 52 C). Block condenser airflow as required to reach this temperature range. Add refrigerant until the system subcooling (SCT.A or SCT.B minus liquid line temperature entering TXV) is approximately 15 to 17 F (-9.4 to -8.3 C). Refrigerant VAPOR only may be added to a circuit through the 1/4-in. suction Schraeder connection on the compressor. This connection is located in line and to the left of the compressor junction box for the SM110 compressors and to the

lower right of the compressor junction box for all other compressor models.

**⚠ CAUTION**

Never charge liquid into low-pressure side of system. Do not overcharge. Overcharging results in higher discharge pressure, possible compressor damage, and higher power consumption. During charging or removal of refrigerant, be sure water is continuously circulating through the cooler to prevent freezing. Damage caused by freezing is considered abuse and may void the Carrier warranty.

**Operating Limitations**

TEMPERATURES (See Table 41 for 30RA Standard Temperature Limits)

**⚠ CAUTION**

Do not operate with cooler leaving chiller water (fluid) temperature (LCWT) below 40 F (4.4 C) for the standard units, or below 15 F (-9.4 C) for units factory built for medium temperature brine.

High Cooler Leaving Chilled Water (Fluid) Temperatures (LCWT) — During start-up with cooler LCWT above approximately 60 F (16 C), the unit expansion valve will limit suction pressure to approximately 90 psig (620 kPa) to avoid overloading the compressor.

Low Cooler LCWT — For standard units, the LCWT must be no lower than 40 F (4.4 C). If the unit is the factory-installed optional medium temperature brine unit, the cooler LCWT can go down to 15 F (-9.4 C).

**Table 41 — Temperature Limits for Standard 30RA Units**

UNIT SIZE 30RA Temperature	010-030		032-055	
	F	C	F	C
Maximum Ambient Temperature	120	49	120	49
Minimum Ambient Temperature	45	7	32	0
Maximum Cooler EWT*	95	35	95	35
Maximum Cooler LWT	70	21	70	21
Minimum Cooler LWT†	40	4.4	40	4.4

**LEGEND**

EWT — Entering Fluid (Water) Temperature  
LWT — Leaving Fluid (Water) Temperature

\*For sustained operation, EWT should not exceed 85 F (29.4 C).  
†Unit requires modification below this temperature.

**LOW-AMBIENT OPERATION** — If operating temperatures below 45 F (7 C) for sizes 010-030 or below 32 F (0° C) for sizes 032-055 are expected, accessory Motormaster® V control must be installed. Refer to separate installation instructions for operation using this accessory. Contact your Carrier representative for details.

**⚠ CAUTION**

Brine duty application (below 40 F [4.4 C] LCWT) for chiller normally requires factory modification. Contact your Carrier representative for applicable LCWT range for standard water-cooled chiller in a specific application.

**VOLTAGE — ALL UNITS**

**Main Power Supply** — Minimum and maximum acceptable supply voltages are listed in the Installation Instructions.

**Unbalanced 3-Phase Supply Voltage** — *Never operate a motor where a phase imbalance between phases is greater than 2%.* To determine percent voltage imbalance:

$$\% \text{ Voltage Imbalance} = 100 \times \frac{\text{max voltage deviation from avg voltage}}{\text{average voltage}}$$

The maximum voltage deviation is the largest difference between a voltage measurement across 2 legs and the average across all 3 legs.

Example: Supply voltage is 240-3-60.

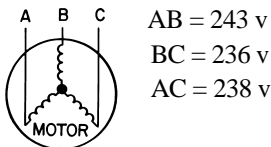

AB = 243 v  
BC = 236 v  
AC = 238 v

1. Determine average voltage:

$$\begin{aligned} \text{Average voltage} &= \frac{243 + 236 + 238}{3} \\ &= \frac{717}{3} \\ &= 239 \end{aligned}$$

2. Determine maximum deviation from average voltage:

$$\begin{aligned} (\text{AB}) \quad &243 - 239 = 4 \text{ v} \\ (\text{BC}) \quad &239 - 236 = 3 \text{ v} \\ (\text{AC}) \quad &239 - 238 = 1 \text{ v} \end{aligned}$$

Maximum deviation is 4 v.

3. Determine percent voltage imbalance:

$$\begin{aligned} \% \text{ Voltage Imbalance} &= 100 \times \frac{4}{239} \\ &= 1.7\% \end{aligned}$$

This voltage imbalance is satisfactory as it is below the maximum allowable of 2%.

**IMPORTANT:** If the supply voltage phase imbalance is more than 2%, contact your local electric utility company immediately. Do not operate unit until imbalance condition is corrected.

**Control Circuit Power** — Power for the control circuit is supplied from the main incoming power through a factory-installed control power transformer (TRAN1) for all models. Field wiring connections are made to either terminal block TB5 or TB6.

**OPERATION SEQUENCE**

During unit off cycle, the control monitors the outdoor air temperature. If the ambient temperature drops below 40 F (4.4 C), cooler and hydronic system heaters (if either are factory installed) are energized. If power is maintained to the chiller and the EMERGENCY ON/OFF switch is left in the OFF position, these heaters are also energized.

The unit is started by putting the ENABLE/OFF/REMOTE CONTACT switch in the ENABLE or REMOTE CONTACT position. When the unit receives a call for cooling (either from the internal control or CCN network command or remote contact closure), the unit stages up in capacity to maintain the leaving fluid set point. The first compressor starts 1½ to 3 minutes after the call for cooling.

The lead circuit can be specifically designated on all models or selected based on compressor run hours and starts depending on field configuration. The unit control will override this selection under certain starting conditions to properly maintain oil return to the compressors. In general, on dual compressor circuits, the control will most often start the A1 or B1 compressor first, especially after long off periods. The MBB controls fan stages to maintain the head pressure set point and will automatically adjust unit capacity as required to keep compressors from operating outside of the specified envelope. There are no pumpout or pumpdown sequences on these chillers.

For all units, if temperature reset is being used, the unit controls to a higher leaving-fluid temperature as the building load reduces. If demand limit is used, the unit may temporarily be unable to maintain the desired leaving-fluid temperature because of imposed power limitations. Loading sequence for compressors is shown in Tables 6 and 7.