

30RA010-018 AQUA SNAP

UNIT POWER DISCONNECT OPTION STANDARD UNIT ALL MODELS

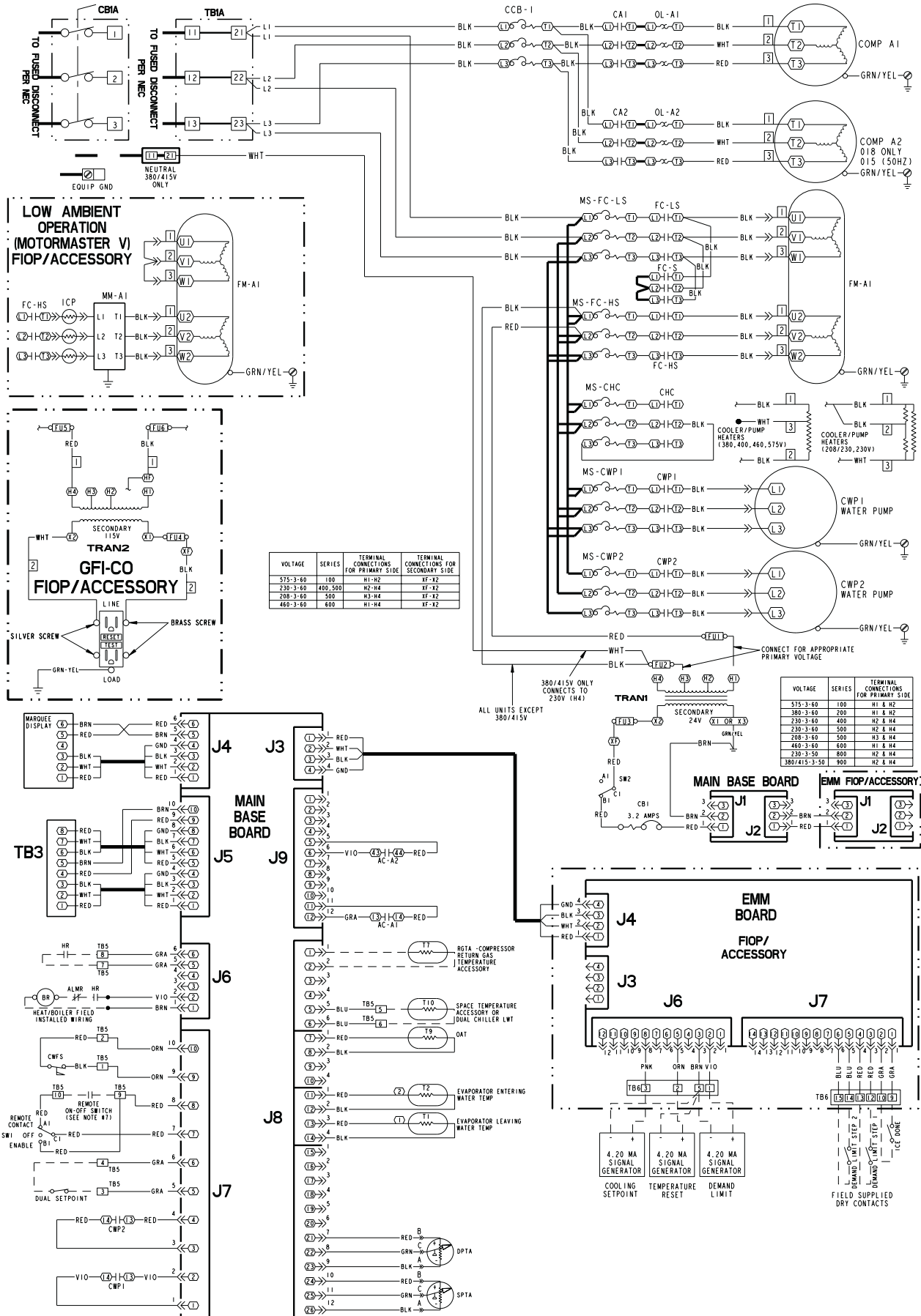

Fig. 3 — Wiring Schematic 30RA010-018

AQUA-SNAP LOW VOLTAGE CONTROL SCHEMATIC (010-018)

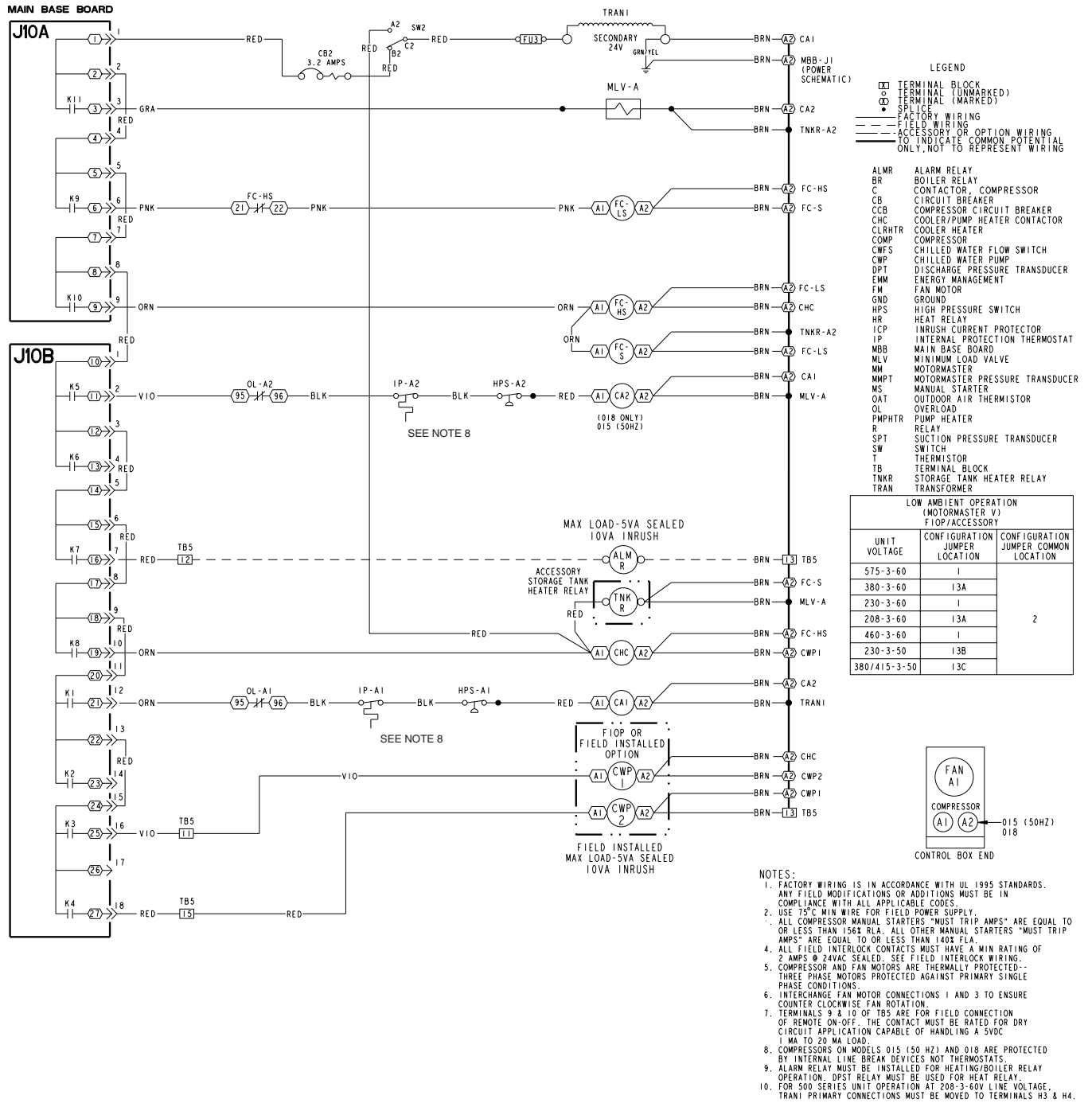

Fig. 3 — Wiring Schematic 30RA010-018 (cont)

30RA022-030 AQUA SNAP

UNIT POWER DISCONNECT OPTION
STANDARD UNIT ALL MODELS

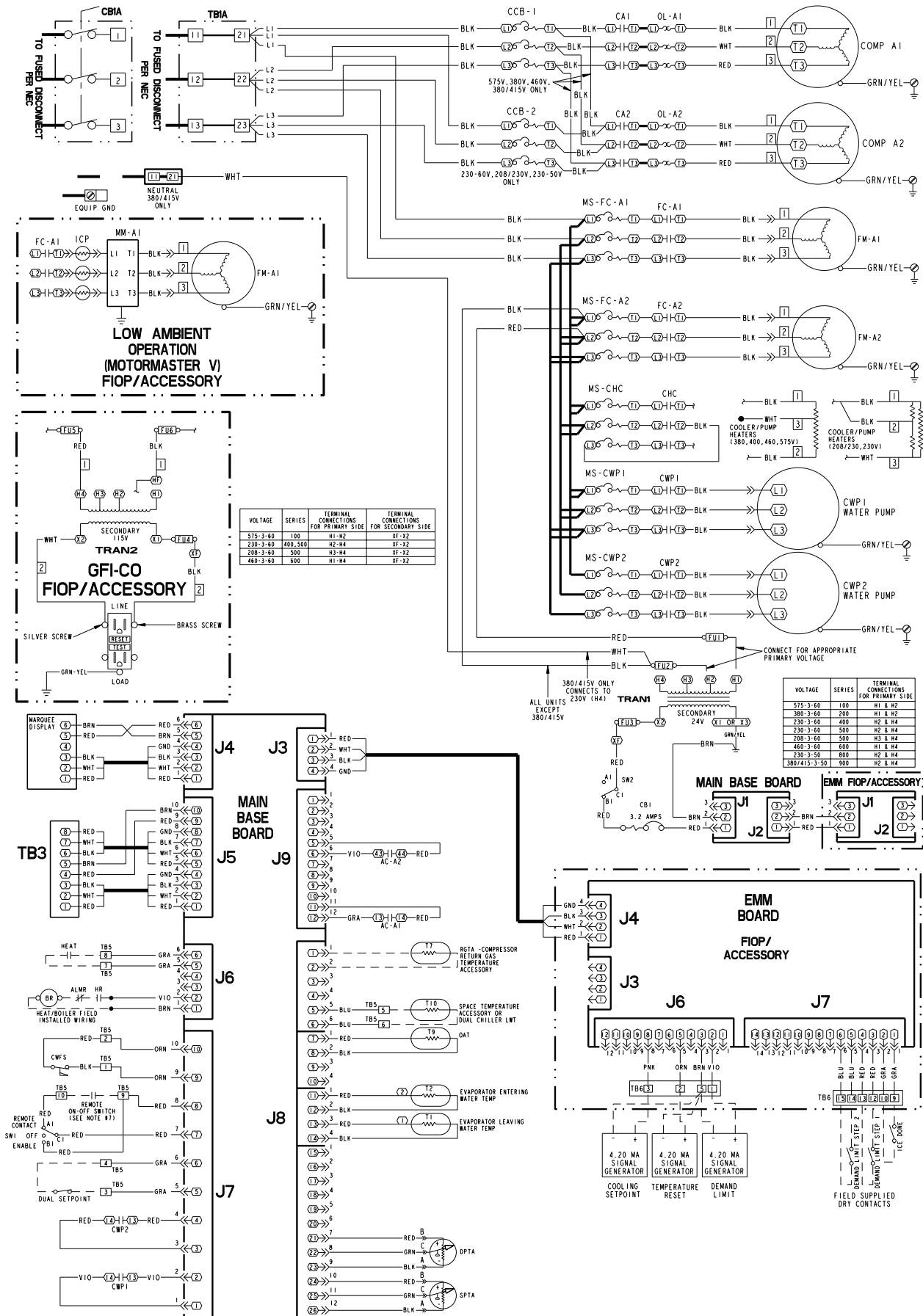

Fig. 4 — Wiring Schematic 30RA022-030

AQUA-SNAP LOW VOLTAGE CONTROL SCHEMATIC (022-030)

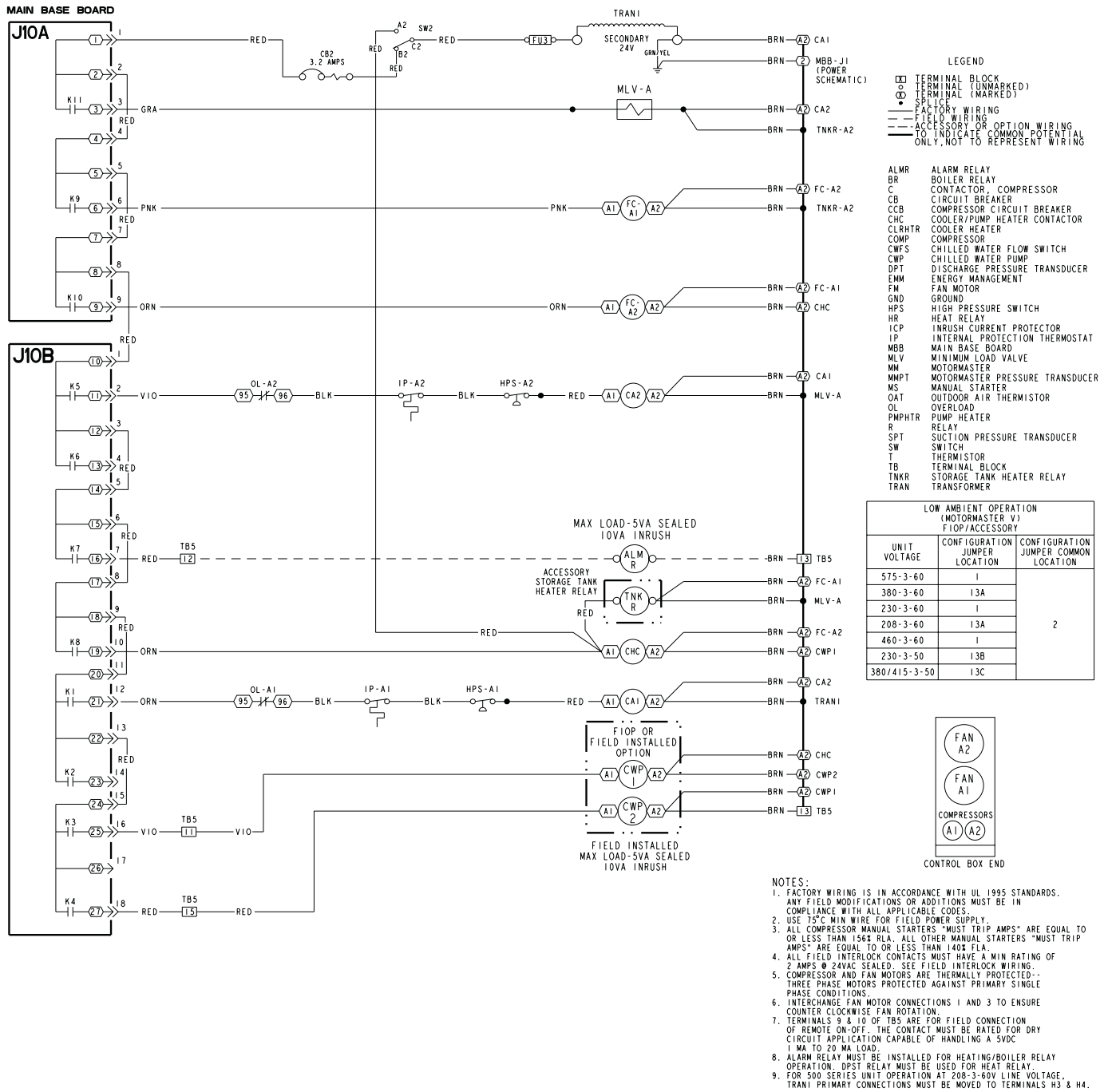

Fig. 4 — Wiring Schematic 30RA022-030 (cont)