



Operators Manual

Installation, Operation & Service

Automatic Water Cooling

MODEL: AWC-1

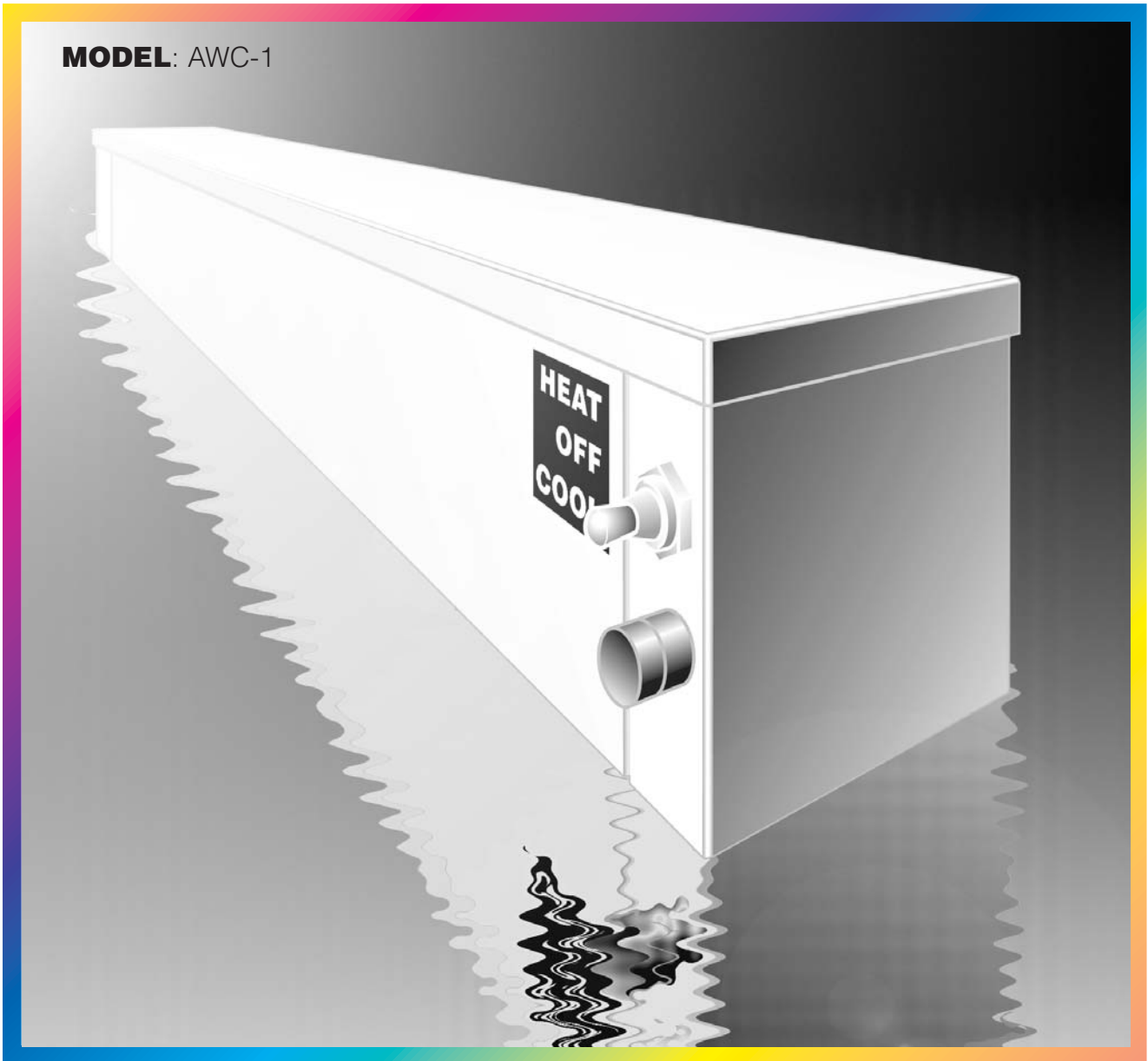

1333 East 179th St., Cleveland, Ohio, U.S.A. 44110

Enodis

Phone: (216) 481-4900 Fax: (216) 481-3782
Visit our web site at www.clevelandrange.com

TABLE OF CONTENTS

<i>Installation & Operation</i>	<i>General</i>	1
	<i>Inspection</i>	1
	<i>Shipping Damage Instruction</i>	1
	<i>Assembly</i>	1
	<i>Care & Cleaning</i>	1
	<i>Warranty</i>	1
	<i>Installation Drawing</i>	2
<i>Service Parts</i>	<i>Internal Components</i>	3-4
	<i>External Plumbing Components</i>	5
<i>Maintenance</i>	<i>General Maintenance</i>	6
	<i>Solenoid Valve Maintenance</i>	6-7
	<i>Wiring Diagrams</i>	8

INSTALLATION & OPERATION

GENERAL

Installation of the Automatic Water Cooling System must be accomplished by qualified installation personnel working to all applicable local and national codes. Improper installation of product could cause injury or damage.

This unit is built to comply with applicable standards for manufacturers. Included among those approval agencies are: UL, NSF, ASME/Ntl.Bd., CSA, ETL, CE, and others. Many local codes exist, and it is the responsibility of the owner/installer to comply with these codes.

INSPECTION

Before uncrating, visually inspect the unit for evidence of damage during shipping. If damage is noticed, do not unpack the unit, follow shipping damage instructions.

SHIPPING DAMAGE INSTRUCTIONS

If shipping damage to the unit is discovered or suspected, observe the following guidelines in preparing a shipping damage claim.

1. Write down a description of the damage or the reason for suspecting damage as soon as it is discovered. This will help in filling out the claim forms later. If possible, take a polaroid picture.
2. As soon as damage is discovered or suspected, notify the carrier that delivered the shipment.
3. Arrange for the carrier's representative to examine the damage.
4. Fill out all carrier claims forms and have the examining carrier sign and date each form.

ASSEMBLY

1. Locate in an area close to the kettle and accessible for operation to use Heat/Off/Cool switch.
2. Fasten unit to wall using lag bolts or other suitable fasteners.
3. Install plumbing components as shown in installation drawing.
4. Turn on steam and water sources.

CARE & CLEANING

1. Disconnect unit power source by unplugging power cord from wall receptacle.
2. Prepare a warm water and mild detergent solution.
3. Using a clean cloth wipe the units exterior. For food deposits a nylon brush can be used.

WARNING: Steel wool should never be used for cleaning the water cooling. Particles of the steel wool become embedded in the surface and rust. This will weaken and corrode the stainless steel surface.

WARRANTY

Our Company supports a worldwide network of Maintenance and Repair Centers. Contact your nearest Maintenance and Repair Centre for replacement parts, service, or information regarding the proper maintenance and repair of your cooking equipment

In order to preserve the various agency safety certification (UL, NSF, ASME/Ntl. Bd., etc.), only factory-supplied replacement parts should be used. The use of other than factory supplied replacement parts will void warranty.

INSTALLATION DRAWING

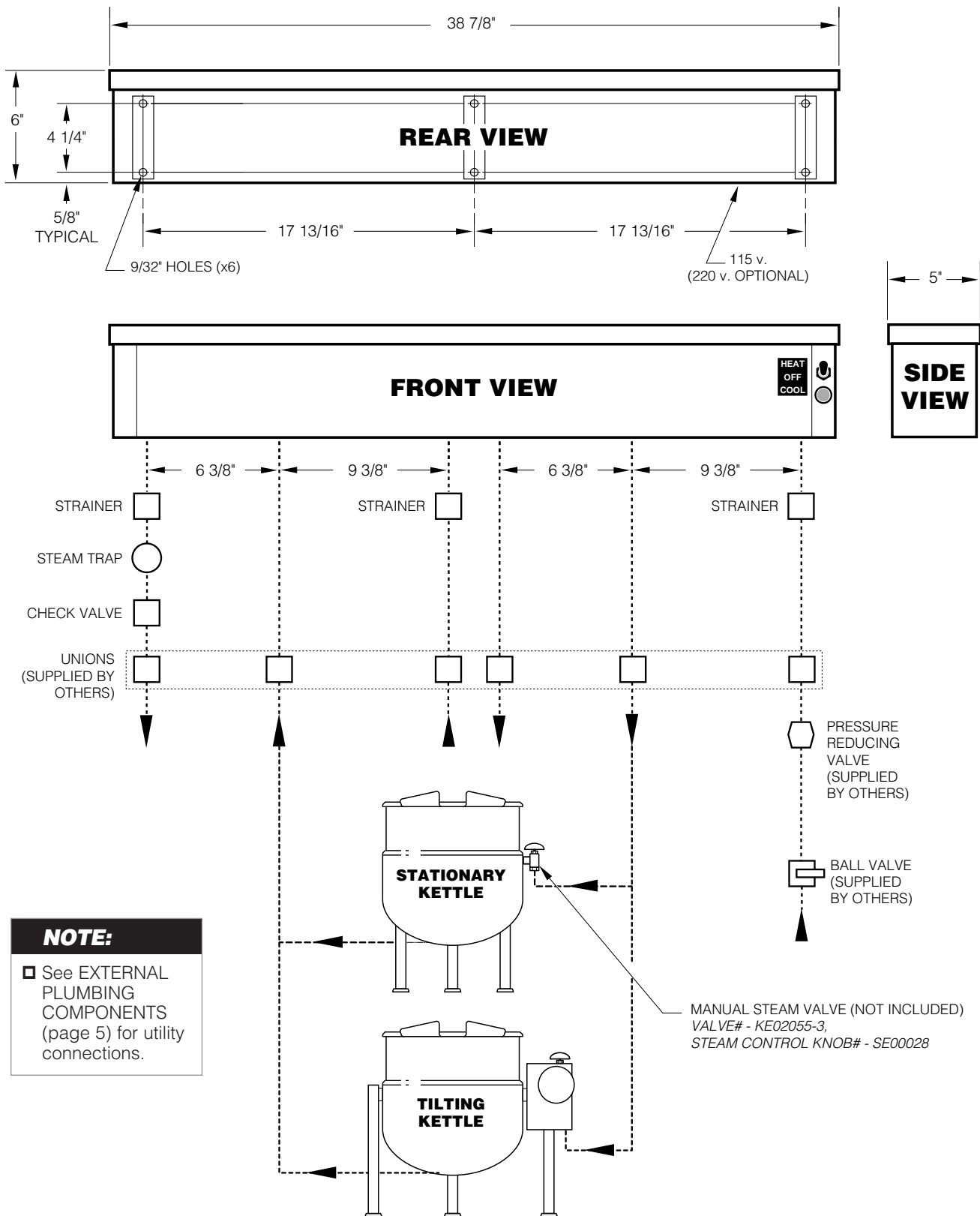

NOTE:

See EXTERNAL PLUMBING COMPONENTS (page 5) for utility connections.

INTERNAL COMPONENTS

ITEM NO.	PART NO.	DESCRIPTION	QTY.
1.	KE951505	Cover	1
2.	FA10239	Screw, #10-32 x 3/8" lg., SS	2
3.	KE01887	Front Panel	1
4.	FA11148	Screw, #10-32 x 3/4" lg., SS	3
5.	KE50473	Ground Lug	1
6.	SK50055-1	Terminal Block	2
7.	SK50054-1	Terminal Block End	1
8.	KE50504	Switch, ON/OFF	1
9.	SK50062	Rubber Boot	1
10.	SK50371	Fuse Holder	1
11.	SK50445	Fuse	1
12.	KE54834-3	* Solenoid Valve, 3/4" NTP. (steam)	1
	SE50405	Solenoid Valve Rebuilt Kit	
	SE50406	Solenoid Valve Replacement Coil	
13.	KE54834-5	* Solenoid Valve, 3/4" NTP. (water)	3
	SE50407	Solenoid Valve Rebuilt Kit	
	SE50401	Solenoid Valve Replacement Coil	
14.	FI00152	Street Elbow, 3/4 NPT.	4
15.	FI050271	Piping Strap	4
16.	FA11146	Screw, #10-32 x 1/2" lg., SS	8
17.	FI00629-1	Nipple, 3/4 NPT x 2" lg.	4
18.	FI00629-36	Close Nipple, 3/4 NPT.	2
19.	FI00179	Tee, 3/4 x 3/4 x 3/4 NPT.	2
20.	KE51653	Check Valve, 3/4 NTP.	2
21.	KE53838-9	Transformer, 220/120V, 50/60 Hz., (220V option)	1

***NOTE:** See SOLENOID VALVE MAINTENANCE section for further information.

EXTERNAL PLUMBING COMPONENTS

NOTES: All connections 3/4" NPT.

ITEM NO.	PART NO.	DESCRIPTION	QTY.
1.	KE52700	Check Valve, 1/2 NPT.	1
2.	FI05147	Nipple, 1/2 NPT. x 1/2" lg.	2
3.	FI05025	Street Elbow, 1/2 NPT.	1
4.	KE52701	Steam Trap, 1/2 NPT.	1
5.	KE52702	"Y" Strainer, 1/2 NPT.	1
6.	KE51654	"Y" Strainer, 3/4 NPT	2
7.	FI00250	Plug for "Y" Strainer (KE51654)	2

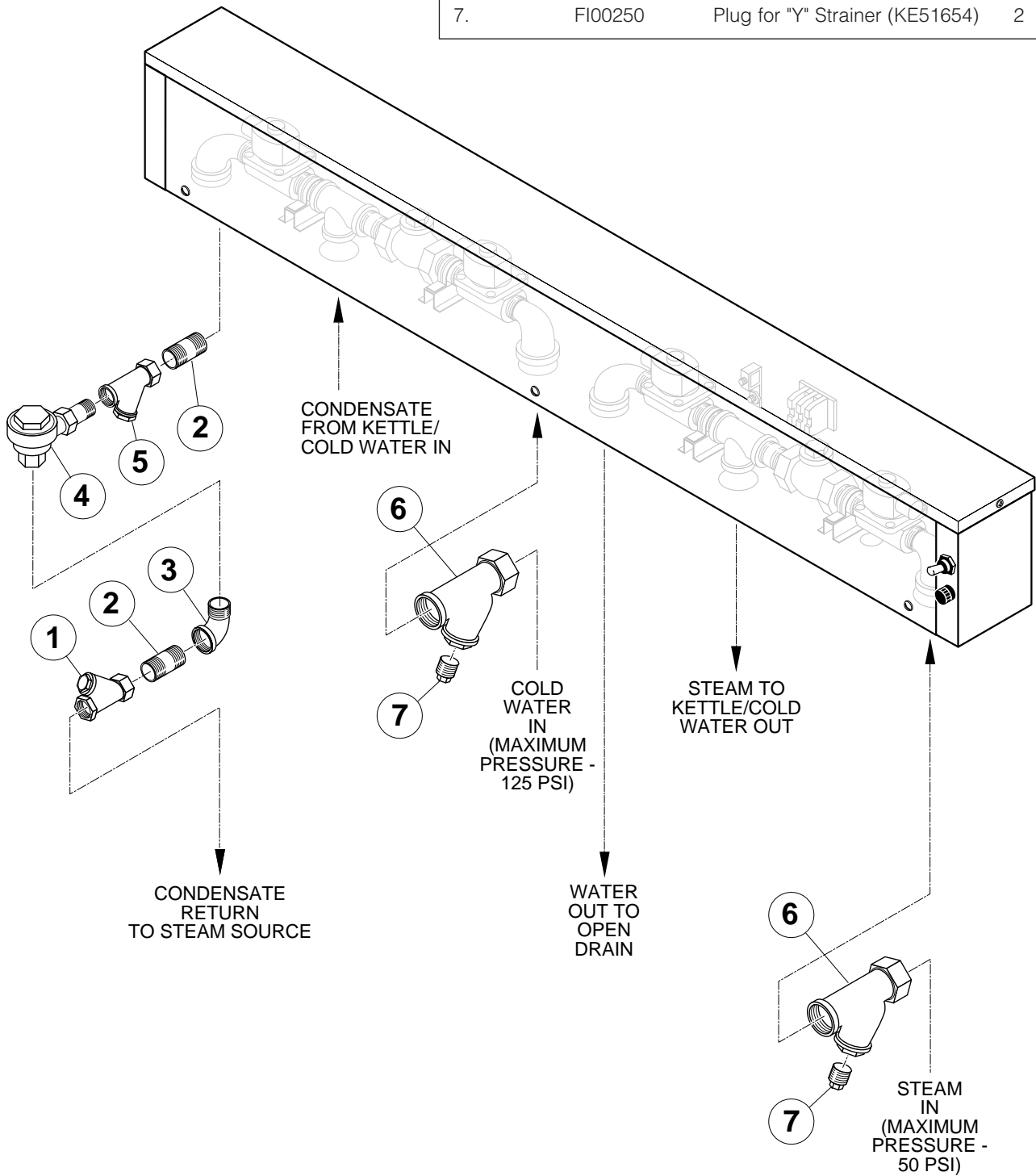

MAINTENANCE

GENERAL MAINTENANCE

An Automatic Water Cooling System requires very little preventive maintenance, other than daily cleaning.

SOLENOID VALVE MAINTENANCE

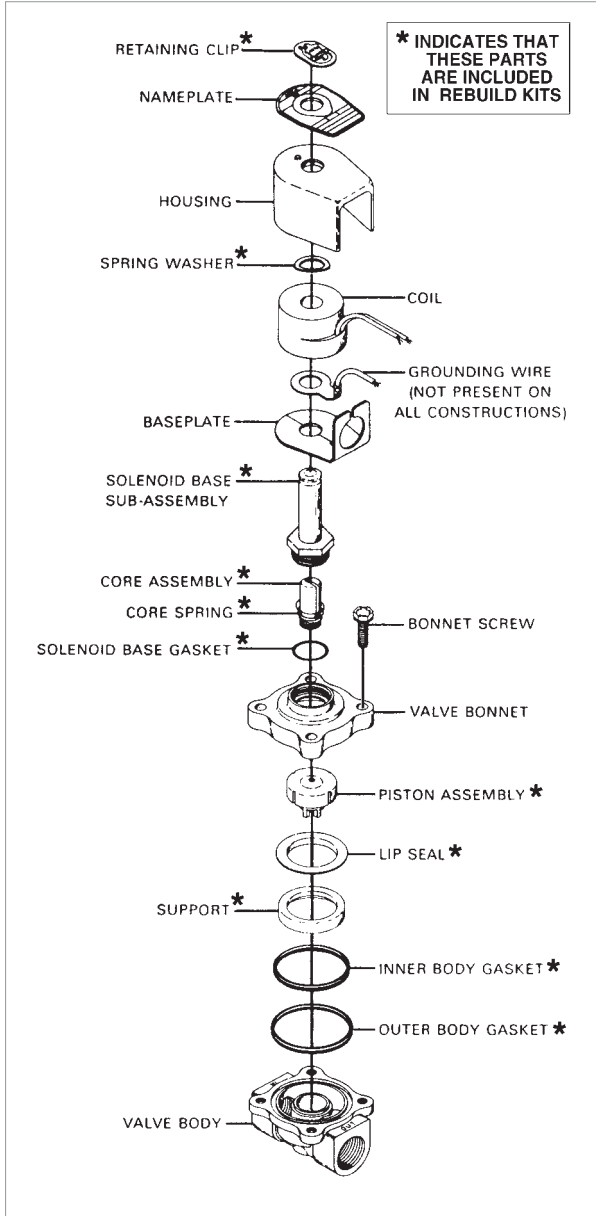

Solenoid Valve Exploded View Drawing

Ordering Information

Parts marked with an asterisk (*) in the Solenoid Valve Exploded View Drawing are supplied in the Rebuild Kits.

Valve# (Description)	Rebuild Kit#	Replacement Coil#
CT50182 (2", 120V/60 Hz.)	SE50400	SE50401
CT50244 (1", 120V/60 Hz.)	SE50402	SE50401
CT50245 (1", 120V/60 Hz.)	SE50403	SE50404
KE51652 (3/4", 120V/60 Hz.)	SE50405	SE50406
KE51656 (3/4", 120V/60 Hz., HW)	SE50407	SE50401
KE52668 (3/8", 120V/60 Hz.)	SE50408	SE50404
KE53007 (1 1/4", 120V/60 Hz.)	SE50409	SE50404
KE53159 (3/4", 120V/60 Hz.)	SE50410	SE50404

NOTE: It is not necessary to remove the valve from the pipeline for repairs.

WARNING: Turn off electrical power supply and depressurize valve before making repairs.

Cleaning

All solenoid valves should be cleaned periodically. The time between cleanings will vary depending on the medium and service conditions. In general, if the voltage to the coil is correct, sluggish valve operation, excessive noise or leakage will indicate that cleaning is required. Clean valve strainer or filter when cleaning the valve.

Preventive Maintenance

1. Keep the medium flowing through the valve as free from dirt and foreign material as possible.
2. While in service, the valve should be operated at least once a month to insure proper opening and closing.
3. Depending on the medium and service conditions, periodic inspection of internal valve parts for damage or excessive wear is recommended. Thoroughly clean all parts. Replace worn or damaged parts. However, for best results, replace all parts as supplied with a Rebuild Kit.

Causes of Improper Operation

1. *Faulty Control Circuits:* Check the electrical system by energizing the solenoid. A metallic "click" signifies that the solenoid is operating. Absence of the "click" indicates loss of power supply. Check for loose or blown fuses, open circuited or grounded coil, broken lead wires or splice connections.
2. *Burned-Out Coil:* Check for open-circuited coil. Replace coil as necessary. Check supply voltage; it must be the same as specified on nameplate.

3. *Low Voltage:* Check voltage across the coil lead. Voltage must be at least 85% of nameplate rating.
4. *Incorrect Pressure:* Check valve pressure. Pressure to valve must be within range specified on nameplate.
5. *Excessive Leakage:* Disassemble valve and clean all parts. If leakage continues, replace all parts as supplied with a Rebuild Kit.

Coil Replacement

WARNING: Turn off electrical power supply.

1. Disconnect coil lead wires and green grounding wire if present.
2. Remove retaining clip, nameplate and housing.

WARNING: When metal retaining clip disengages, it will spring upward.

3. Slip spring washer and coil off the solenoid base subassembly.
4. Coil is now accessible for replacement. Reassemble in reverse order of disassembly. Use Solenoid Valve Exploded View Drawing for identification and placement of parts.

CAUTION: Solenoid must be fully reassembled because the housing and internal parts complete the magnetic circuit.

Valve Disassembly

WARNING: Depressurize valve and turn off electrical power supply.

1. Disassemble valve in an orderly fashion. Use exploded view for identification and placement of parts.
2. If necessary, disconnect coil lead wires, grounding wire (if present), and rigid conduit from solenoid housing,
3. Remove retaining clip and slip the entire solenoid enclosure off the solenoid base sub-assembly.

WARNING: When metal retaining clip disengages, it will spring upward,

4. Unscrew solenoid base sub-assembly and remove core assembly, core spring, and solenoid base gasket.

5. Remove bonnet screws, valve bonnet, piston assembly, lip seal, support, inner and outer body gaskets.
6. All parts are now accessible to clean or replace; Replace worn or damaged parts. However, for best results, replace all parts as supplied with an Rebuild Kit.

Valve Reassembly

1. Reassemble in reverse order of disassembly. Use exploded view for identification and placement of parts.
2. Lubricate all gaskets with DOW CORNING 111® Compound lubricant or an equivalent high-grade silicone grease.
3. Position support and inner and outer body gaskets in valve body.
4. Position lip seal, flanged end up, onto piston assembly. Install piston assembly with lip seal into support in valve body cavity.
5. Replace valve bonnet and bonnet screws. Torque bonnet screws in a crisscross manner to 95 ±10 inch-pounds (10,7 ±1,1 newton-meters).
6. Replace solenoid base gasket, core assembly, and solenoid base sub-assembly. Torque solenoid base sub-assembly to 175 ±25 inch-pounds (19,8 ±2,8 newton-meters).
7. Replace solenoid enclosure and retaining clip.
8. Restore line pressure and electrical power supply to valve.
9. After maintenance is completed, operate the valve a few times to be sure of proper opening and closing.

WIRING DIAGRAM

115v 1 ph

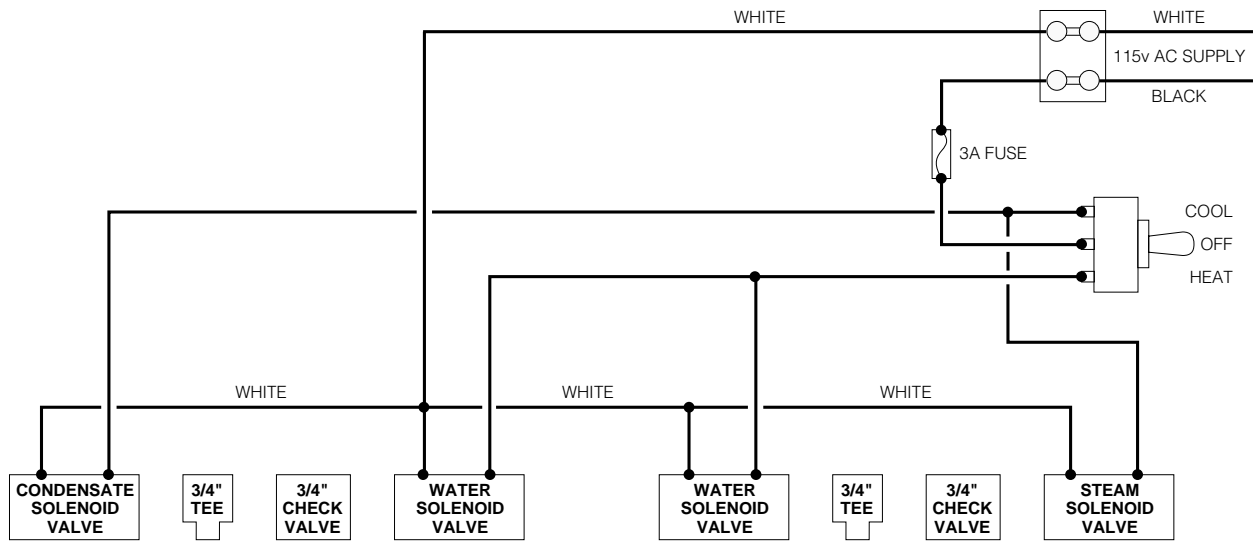

220v 1 ph

