

# Cleveland

## Service Manual

### STEAMPRO XVI PRESSURE / CONVECTION STEAMER

MODELS: 9-PCEM-48-L  
9-PCGM-250-L  
9-PCGM-300-L  
9-PCDM-L  
9-PCSM-L

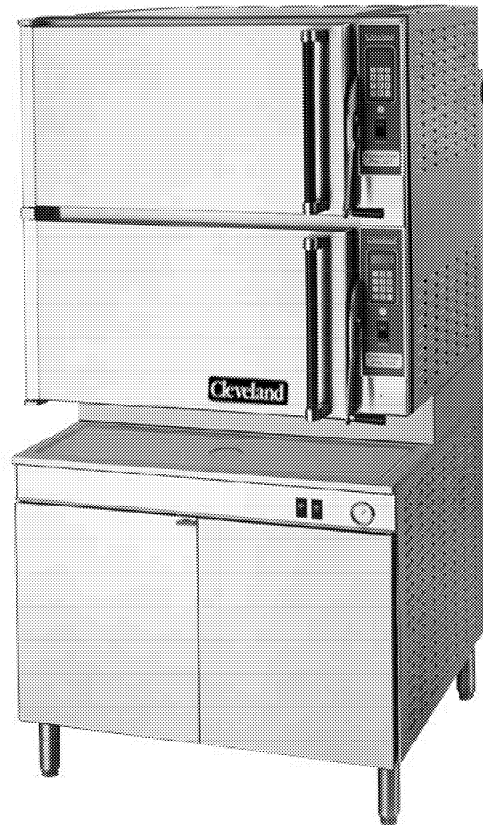

PCS-02 6/01

2/04

# Cleveland STATEMENT OF POLICIES

## LIMITED WARRANTY

CLEVELAND RANGE products are warranted to the original purchaser to be free from defects in materials and workmanship under normal use and service for the standard warranty period of one year from date of installation or 18 months from date of shipment, whichever ever comes first.

CLEVELAND RANGE agrees to repair or replace, at its option, f.o.b. factory, any part which proves to be defective due to defects in material or workmanship during the warranty period, providing the equipment has been unaltered, and has been PROPERLY INSTALLED, MAINTAINED, AND OPERATED IN ACCORDANCE WITH THE CLEVELAND RANGE OWNER'S MANUAL.

CLEVELAND RANGE agrees to pay any FACTORY AUTHORIZED EQUIPMENT SERVICE AGENCY (within the continental United States, and Hawaii) for reasonable labor required to repair or replace, at our option, f.o.b. factory, any part which proves to be defective due to defects in material or workmanship, during the labor warranty period. This warranty includes travel time not to exceed two hours and mileage not to exceed 50 miles (100 miles round-trip), BUT DOES NOT INCLUDE POST START-UP, TIGHTENING LOOSE FITTINGS, MINOR ADJUSTMENTS, MAINTENANCE, CLEANING OR DESCALING.

The standard labor warranty allows factory payment of reasonable labor required to repair or replace such defective parts. Cleveland Range will not reimburse the expense of labor required for the repair or replacement of parts after the standard warranty period, unless an Extended Labor Warranty Contract has been purchased to cover the equipment for the balance of the warranty period from the date of equipment installation, start-up, or demonstration.

PROPER INSTALLATION IS THE RESPONSIBILITY OF THE DEALER, THE OWNER-USER, OR INSTALLING CONTRACTOR, AND IS NOT COVERED BY THIS WARRANTY. Many local codes exist, and it is the responsibility of the owner and installer to comply with these codes. Cleveland Range equipment is built to comply with applicable standards for manufacturers, including UL, ANSI, NSF, ASME/Ntl. Bd., CSA, and others.

BOILER (Steam Generator) MAINTENANCE IS THE RESPONSIBILITY OF THE OWNER-USER AND IS NOT COVERED BY THIS WARRANTY. The use of good quality feed water is the responsibility of the Owner-User (see Water Quality Recommendations below). THE USE OF POOR QUALITY FEED WATER WILL VOID EQUIPMENT WARRANTIES. Boiler maintenance supplies, including boiler hand hole gaskets, are not warranted beyond the first 90 days after the date the equipment is placed into service. Preventive maintenance records must be available showing descaling per applicable Cleveland Operator Manual for Boiler Proration Program considerations.

### WATER QUALITY RECOMMENDATIONS

TOTAL DISSOLVED SOLIDS	less than	60 parts per million
TOTAL ALKALINITY	less than	20 parts per million
SILICA	less than	13 parts per million
CHLORIDE	less than	30 parts per million
pH FACTOR	greater than	7.5

The foregoing shall constitute the sole and exclusive remedy of original purchaser and the full liability of Cleveland Range for any breach of warranty. THE FOREGOING IS EXCLUSIVE AND IN LIEU OF ALL OTHER WARRANTIES, WHETHER WRITTEN, ORAL, OR IMPLIED, INCLUDING ANY WARRANTY OF PERFORMANCE, MERCHANTABILITY, OR FITNESS FOR PURPOSE, AND SUPERSEDES AND EXCLUDES ANY ORAL WARRANTIES OR REPRESENTATIONS, OR WRITTEN WARRANTIES OR REPRESENTATIONS, NOT EXPRESSLY DESIGNATED IN WRITING AS A "WARRANTY" OR "GUARANTEE" OF CLEVELAND RANGE MADE OR IMPLIED IN ANY MANUAL, LITERATURE, ADVERTISING BROCHURE OR OTHER MATERIALS.

CLEVELAND RANGE'S liability on any claim of any kind, including negligence, with respect to the goods or services covered hereunder, shall in no case exceed the price of the goods or services, or part thereof, which gives rise to the claim. IN NO EVENT SHALL CLEVELAND RANGE BE LIABLE FOR SPECIAL, INCIDENTAL, OR CONSEQUENTIAL DAMAGES, OR ANY DAMAGES IN THE NATURE OF PENALTIES.

## LIMITED EXTENDED WARRANTY COVERAGE

The purchase of a Limited Extended Warranty Contract extends the standard warranty coverage to the purchased period of time (one to two years) from the date of installation, start-up, or demonstration, whichever is sooner.

\*An additional two years Parts and Labor Warranty can be purchased with each piece of Cleveland equipment for an additional 2% of the List Price per year. The 2% of list price charge will be the net invoice amount for each year of extended warranty purchased.

- Extended warranty must be purchased at the same time the equipment is purchased.
- Extended Warranty has the same exclusions as stated in our standard warranty.

Second year limited extended warranty coverage on Cleveland Steamers when purchased with a water filter applies to water related components only.

# Cleveland|ALCO

## PUBLICATION IMPROVEMENT RECOMMENDATION

Users of this publication are encouraged to report errors, omissions and their recommendations for improving the publication. This sheet is provided for that purpose. To file a Publication Improvement Recommendation, fill in the information requested below, fold, tape and mail this prepaid business reply form.

This Publication Improvement Recommendation pertains to manual \_\_\_\_\_

\_\_\_\_\_ Publication Date of Manual

The following information was discovered during: (check one)

Installation  
 Other (specify) \_\_\_\_\_

Recommendation: \_\_\_\_\_  
(Be specific by referencing your remarks to page numbers, step numbers, etc.)

\_\_\_\_\_  
\_\_\_\_\_  
\_\_\_\_\_  
\_\_\_\_\_  
\_\_\_\_\_  
\_\_\_\_\_  
\_\_\_\_\_  
\_\_\_\_\_

(Continue other side)

Your name \_\_\_\_\_  
(Please print)

Service office \_\_\_\_\_  
(City) (State)

Telephone \_\_\_\_\_  
(Area code) (Number)



NO POSTAGE  
NECESSARY  
IF MAILED  
IN THE  
UNITED STATES

**BUSINESS REPLY CARD**  
FIRST CLASS PERMIT NO. 1428 CLEVELAND, OHIO

POSTAGE WILL BE PAID BY ADDRESSEE

CLEVELAND RANGE COMPANY  
1333 East 179th Street  
Cleveland, Ohio 44110

Attn.: Literature Department

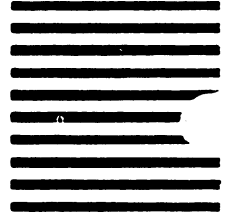

## TABLE OF CONTENTS

	Page
Specification Information .....	
9-PCEM-L (Electric) .....	3-4
9-PCGM-L (Gas) .....	5-6
9-PCDM-L (Direct Steam) .....	7-8
9-PCSM-L (Steam Coil) .....	9-10
Inspection and Unpacking .....	11
Installation Instructions .....	11
Installation Policies .....	11
Installation Instructions for all models .....	11-13
Installation Check .....	13
Introduction to SteamPro XVI Ownership .....	14
Operational Safety .....	14-15
Operational Functions .....	15-17
Control Panel Overview .....	16-17
Timer Information .....	16-17
Timer Programming .....	17
Timer Bypass	
Operating Mode Selection .....	
Basic Sequence of Operation .....	17-18
Start-Up and Preheat .....	18-19
Steaming Operation .....	19
Preventative Maintenance .....	20-21
Steamer Timer Programming Guide .....	22-23
Parts Breakdown .....	24-38
Electrical Wiring Diagram .....	39-40
Maintenance and Repair Center Information .....	41



# SteamPro® XVI

## PRESSURE/CONVECTION STEAMER MODEL: 9-PCEM-48-L

- TWO LARGE COMPARTMENTS
- ELECTRIC STEAM GENERATOR  
48 KW
- 900mm CABINET BASE

ITEM NUMBER \_\_\_\_\_

JOB NAME / NUMBER \_\_\_\_\_

### General Specifications:

- Pressure or Convection steam cooking. Each compartment independently operational in Pressure or Convection mode, user selectable
- In Convection mode, cooking compartment operates without pressure, permitting door to be opened while cooking continues
- In Pressure mode, door is locked and sealed
- At any time a compartment becomes pressurized, door will automatically lock for safety
- Solid state, digital timer with wipe clean touch control panel: one per compartment, each with 99 minute capacity plus selectable "Repeat Cycle" feature
- High speed cooking with 10 psi operating pressure
- Standard voltage is 208V, 60 Hz, 3 phase, 3 wire
- Automatic temperature compensated timing action for consistent product results
- Alternate manual operation mode (Convection only)
- "Clean Cove" corners in cooking compartments — easy to clean
- Solid state controls for boiler and steam flow
- 15 psi safety valve
- Insulated cooking compartments
- Type 304 Stainless Steel: cooking compartments, doors, table top
- Exterior sheathing is type 304 Stainless Steel, #4 finish
- Four Stainless Steel legs with level adjustment
- Serviceable from the front: solid state timers, electrical controls and components, all boiler controls and components, compartment drain lines and steam injection tubes
- Capacity for either 12" x 20" pans or 18" x 26" bun pans (none furnished standard)
- Single cold water connection
- Boiler empties under pressure (blows down) automatically upon each shut-down, automatic water fill upon start-up — single button control.\*
- Standard control panel languages are English, French and Spanish

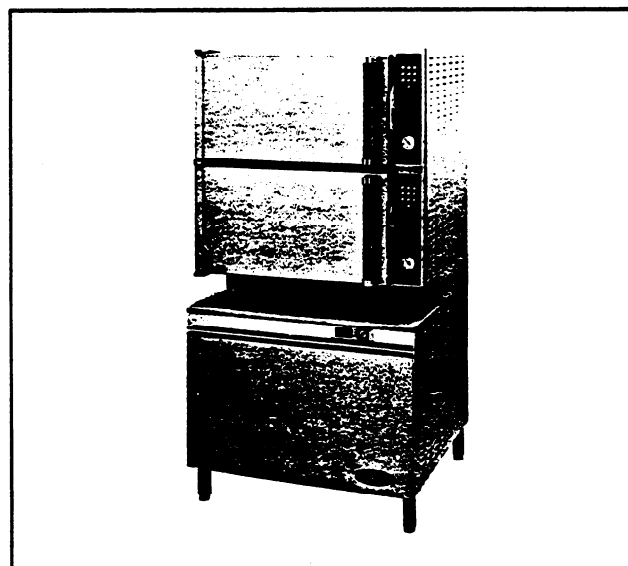

### MODELS AVAILABLE

Model No.	Description
9-PCEM-48-L	2 large size compartments, each compartment independently operational in Pressure or Convection mode, user selectable; 900mm (35.43") modular base; 48 KW electric boiler

### Options and Accessories:

- \*  "California Code" boiler controls compliance kit factory installed. Single button control replaced by two button controls
- Voltages other than standard
- Cooking pans
- 8", 10" or 12" adjustable legs
- Stainless Steel base frame (FSS)

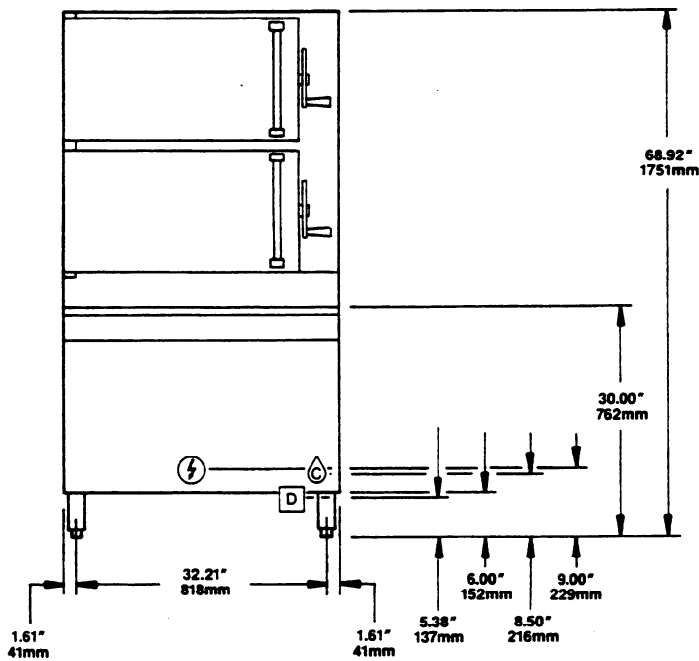
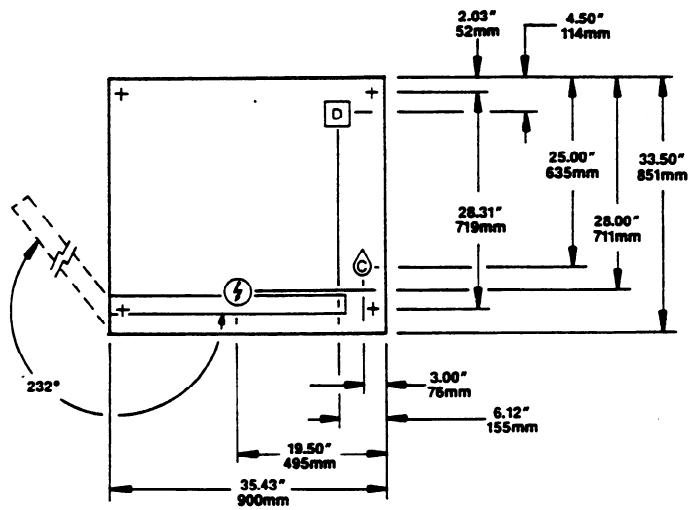

**SHORT FORM SPECIFICATION**

Shall be Two Compartments, CLEVELAND Pressure/Convection Steamer, electric generator, Model 9-PCEM-48-L, 48 KW Electric; \_\_\_\_\_volts, \_\_\_\_\_Hz, \_\_\_\_\_phase, 3 wire. Pressure/Convection modes to be selectable at user's option with no restrictions as to any combination of modes. Type 304 Stainless Steel exterior paneling and cooking compartments. Insulated compartments. One solid state, 99 minute digital timer with touch control per compartment. Audible and visual signals for cycle completion and steam shut-off. Separate visual indication for each operational mode.

- Each compartment has capacity for:  
Eight, 12" x 20" x 2½" pans. Can accommodate 18" x 26" bun pans.
- Many local codes exist and it is the responsibility of the owner and installer to comply with those codes.
- Cleveland/ALCO equipment is built to comply with applicable standards for manufacturers. Included among those approval agencies are: UL, A.G.A., NSF, ASME/N.Bd., CSA, CGA, ETL, and others.

**WATER QUALITY REQUIREMENT**

The recommended minimum water quality standards whether untreated or pre-treated, based upon 10 hours of use per day, and a Daily Blowdown, are as follows:  
 TOTAL DISSOLVED SOLIDS less than 60 parts per million  
 TOTAL ALKALINITY less than 20 parts per million  
 SILICA less than 13 parts per million  
 pH FACTOR greater than 7.5  
 Consult a local water treatment specialist for an on site water analysis for recommendations concerning steam generator feed water treatment (if required), in order to remove or reduce harmful concentrations of minerals. The use of highly mineralized water will mean that more frequent servicing of the steam generator will be necessary. The fact that a water supply is potable is not proof that it will be suitable for the generator.

ELECTRIC ⚡	WATER 💧	DRAINAGE 🗑️	CLEARANCE												
3 PHASE - 48 KW <table border="1"> <tr> <td>208V</td> <td>AMPS PER LINE</td> <td>119</td> </tr> <tr> <td>220V</td> <td>PER</td> <td>127</td> </tr> <tr> <td>240V</td> <td>LINE</td> <td>116</td> </tr> <tr> <td>480V</td> <td></td> <td>58</td> </tr> </table> For power supply use copper wire only.	208V	AMPS PER LINE	119	220V	PER	127	240V	LINE	116	480V		58	35 psi min. 60 psi max. ¼" IPS cold water	1½" IPS common drain. Do not connect any other units to this drain.	RIGHT = 12.00" If adjoining wall or equipment is over 30.00" high. LEFT = 0" REAR = 0"
208V	AMPS PER LINE	119													
220V	PER	127													
240V	LINE	116													
480V		58													

SCALE .50" = 1'

Cleveland/ALCO reserves right of design improvement or modification, as warranted.

# SteamPro® XVI

## PRESSURE/CONVECTION STEAMER

MODELS:  9-PCGM-250-L  
 9-PCGM-300-L

- TWO LARGE COMPARTMENTS
- GAS STEAM GENERATOR  
250 or 300M BTU
- 900mm CABINET BASE

ITEM NUMBER \_\_\_\_\_

JOB NAME / NUMBER \_\_\_\_\_

### General Specifications:

- Pressure or Convection steam cooking. Each compartment independently operational in Pressure or Convection mode, user selectable
- In Convection mode, cooking compartment operates without pressure, permitting door to be opened while cooking continues
- In Pressure mode, door is locked and sealed
- At any time a compartment becomes pressurized, door will automatically lock for safety
- Solid state, digital timer with wipe clean touch control panel, one per compartment, each with 99 minute capacity plus selectable "Repeat Cycle" feature
- Automatic temperature compensated timing action for consistent product results
- Alternate manual operation mode (Convection only)
- "Clean Cove" corners in cooking compartments — easy to clean
- Solid state controls for boiler and steam flow
- 15 psi safety valve
- Insulated cooking compartments
- Type 304 Stainless Steel: cooking compartments, doors, table top
- Exterior sheathing is type 304 Stainless Steel, #4 finish
- Four Stainless Steel legs with level adjustment
- Serviceable from the front: solid state timers, electrical controls and components, all boiler controls and components, compartment drain lines and steam injection tubes
- Capacity for either 12" x 20" pans or 18" x 26" bun pans
- Single cold water connection
- Boiler empties under pressure (blows down) automatically upon each shut-down, automatic water fill upon start-up — single button control.\*
- Standard control panel languages are English, French and Spanish
- Electronic spark ignition

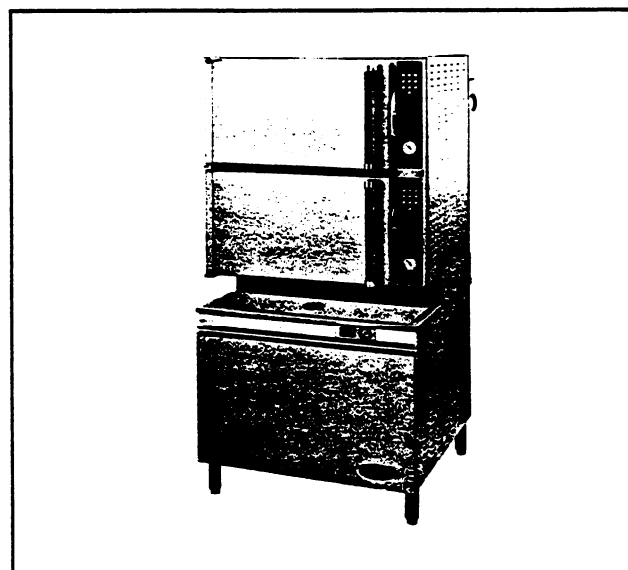

### MODELS AVAILABLE

Model No.	Description
9-PCGM-250-L	2 large size compartments, each compartment independently operational in Pressure or Convection mode, user selectable; 900mm (35.43") modular base 250M-BTU boiler with electronic spark ignition
9-PCGM-300-L	2 large size compartments, each compartment independently operational in Pressure or Convection mode, user selectable; 900mm (35.43") modular base; 300M-BTU boiler with electronic spark ignition

### Options and Accessories:

- \*  "California Code" boiler controls compliance kit factory installed. Single button control replaced by two button controls
- Gas other than natural
- Cooking pans
- 8", 10" or 12" adjustable legs
- Stainless Steel base frame (FSS)

### SHORT FORM SPECIFICATION

Shall be Two Compartments, CLEVELAND Pressure/Convection Steamer, gas generator, Model 9-PCGM-\_\_\_\_-L, \_\_\_\_ Gas, \_\_\_\_ volts, \_\_\_\_ Hz, \_\_\_\_ phase. Pressure/Convection modes to be selectable at user's option with no restrictions as to any combination of modes. Type 304 Stainless Steel exterior paneling and cooking compartments. Insulated compartments. One solid state, 99 minute digital timer with touch control per compartment. Audible and visual signals for cycle completion and steam shut-off. Separate visual indication for each operational mode.

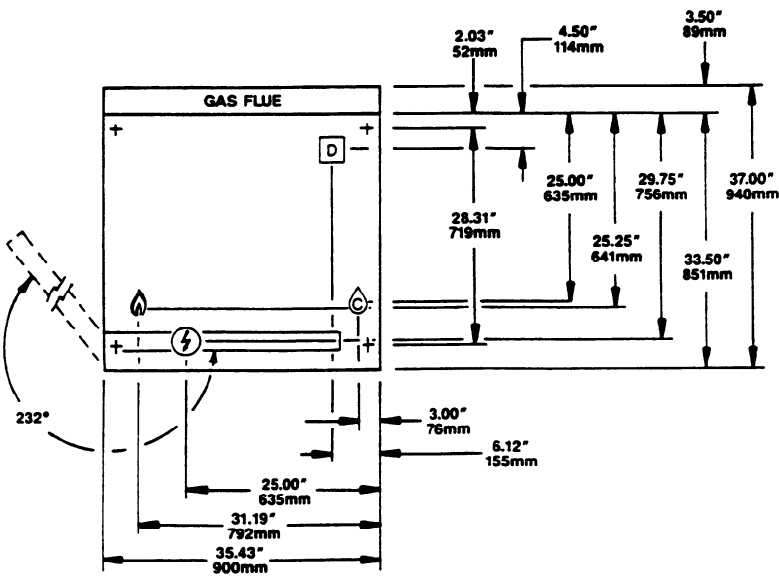

#### •Each compartment has capacity for:

Eight, 12" x 20" x 2½" pans. Can accommodate 18" x 26" bun pans.

•Many local codes exist and it is the responsibility of the owner and installer to comply with those codes.

•Cleveland/ALCO equipment is built to comply with applicable standards for manufacturers. Included among those approval agencies are: UL, A.G.A., NSF, ASME/N.Bd., CSA, CGA, ETL, and others.

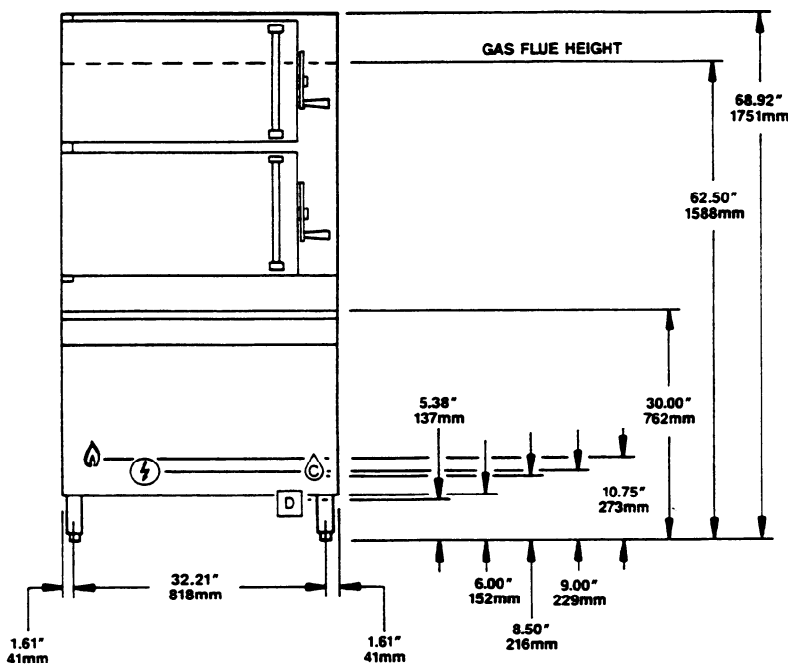

### WATER QUALITY REQUIREMENT

The recommended minimum water quality standards whether untreated or pre-treated, based upon 10 hours of use per day, and a Daily Blowdown, are as follows:

TOTAL DISSOLVED SOLIDS less than 60 parts per million  
 TOTAL ALKALINITY less than 20 parts per million  
 SILICA less than 13 parts per million  
 pH FACTOR greater than 7.5

Consult a local water treatment specialist for an on site water analysis for recommendations concerning steam generator feed water treatment (if required), in order to remove or reduce harmful concentrations of minerals. The use of highly mineralized water will mean that more frequent servicing of the steam generator will be necessary. The fact that a water supply is potable is not proof that it will be suitable for the generator.

GAS		ELECTRIC	WATER	DRAINAGE	CLEARANCE
NATURAL Piping-1" IPS for 240,000 BTU or more. Supply pressure 4.00" W.C. Min. 14.00" W.C. Max.	PROPANE Piping-1" IPS for 240,000 BTU or more. Supply pressure 12.00" W.C. Min. 14.00" W.C. Max.	115V-1 PH 25 watts per compartment. 50 watts boiler control.	35 psi min. 60 psi max. ¼" IPS cold water	1½" IPS common drain. Do not connect any other units to this drain.	RIGHT = 12" If adjoining wall or equipment is over 30.00" high. LEFT = 0" REAR = 0" For use only in non-combustible locations.
Manufacturer must be notified if unit is to be used above 2,000 ft. altitude.					

SCALE 50" = 1'

Cleveland/ALCO reserves right of design improvement or modification, as warranted.

**SteamPro™ XVI  
PRESSURE/CONVECTION STEAMER**

MODEL:  9-PCDM-L

**DIRECT STEAM  
TWO LARGE COMPARTMENTS  
900mm CABINET BASE**

**General Specifications:**

- Pressure or Convection cooking, selected by the user, can be in any combination at the same time, no restrictions
  - In Convection mode, cooking compartment operates without pressure, permitting door to be opened while cooking continues
  - In Pressure mode, door is locked and sealed
  - At any time a compartment becomes pressurized, door will automatically lock for safety
  - Solid state, digital timer with wipe clean touch control panel, one per compartment, each with 99 minute capacity plus selectable "Repeat Cycle" feature
  - High speed cooking with 10 psi operating pressure
  - Automatic temperature compensated timing action for consistent product results
  - Alternate manual operation mode (Convection only)
  - "Clean Cove" corners in cooking compartments — easy to clean
  - 15 psi safety valve
  - Insulated cooking compartments
  - Type 304 Stainless Steel: cooking compartments, doors, table top
  - Exterior sheathing is Type 304 Stainless Steel, #4 finish
  - Four Stainless Steel legs with level adjustment
  - Serviceable from the front: solid state timers, electrical controls and components, compartment drain lines and steam injection tubes
  - Capacity for either 12" x 20" pans or 18" x 26" bun pans (none furnished standard)
  - Single cold water connection
  - Standard control panel languages are English, French, and Spanish
- △ Clean, non-toxic, uncontaminated steam is required at the steamer

ITEM NUMBER \_\_\_\_\_

JOB NAME / NUMBER \_\_\_\_\_



**MODELS AVAILABLE**

Model No.	Description
9-PCDM-L	2 large size compartments, each compartment independently operational in pressure or convection mode, user selectable; 900mm (35.43") modular base

**Options and Accessories:**

- Reversed door opening: hinges at right, controls on left
- Cooking pans
- 8", 10" or 12" adjustable legs
- Stainless steel base frame (FSS)

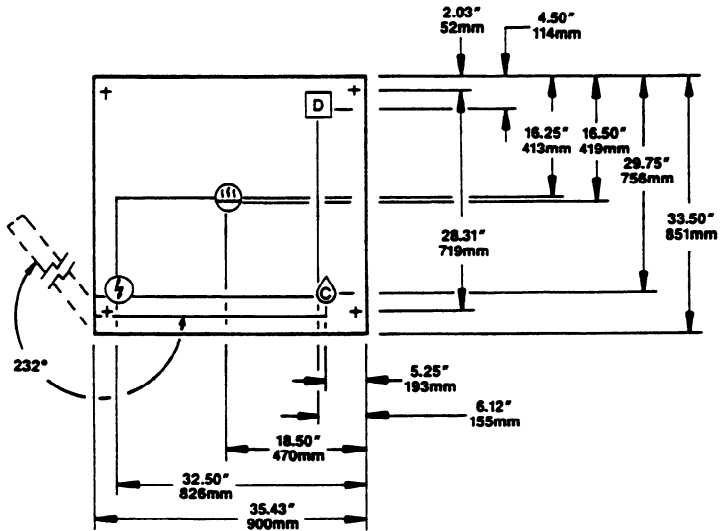

### SHORT FORM SPECIFICATION

Shall be Two Compartments, CLEVELAND, Pressure/Convection Steamer, direct steam, Model 9-PCDM-L, Pressure/Convection modes to be selectable at user's option with no restrictions as to any combination of modes. Type 304 Stainless Steel exterior paneling and cooking compartments. Insulated compartments. One Solid state, 99 minute digital timer with touch control per compartment. Audible and visual signals for cycle completion and steam shut-off. Separate visual indication for each operational mode.

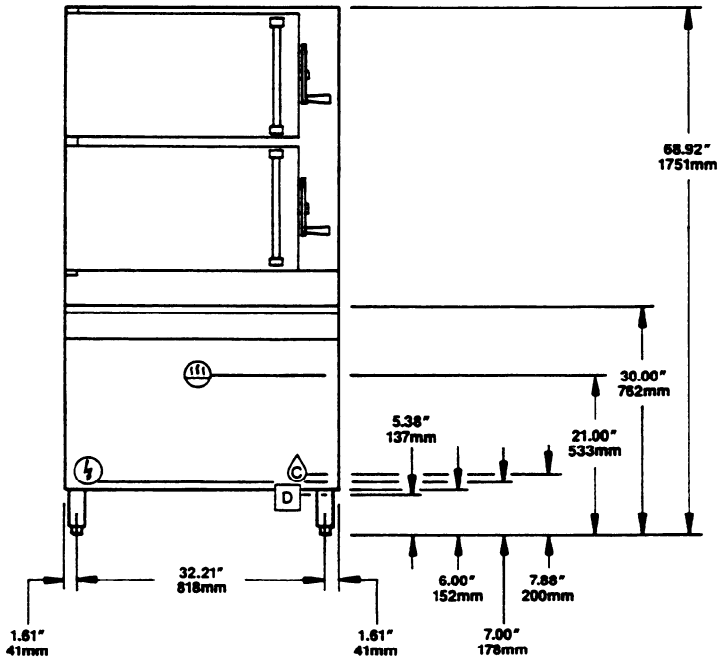

- Each compartment has capacity for:  
Eight, 12" x 20" x 2 1/2" pans. Can accommodate 18" x 26" bun pans.
- Many local codes exist and it is the responsibility of the owner and installer to comply with those codes.
- Cleveland/ALCO equipment is built to comply with applicable standards for manufacturers. Included among those approval agencies are: UL, A.G.A., NSF, ASME/N.Bd., CSA, CGA, ETL, and others.



DIRECT STEAM	WATER 	DRAINAGE 	ELECTRIC 	CLEARANCE
Steam Supply: Furnish 3/4" IPS min. line. 40 psi min. 50 psi max. required. for pressures above 50 psi, an additional pressure reducing valve must be specified.	40 psi min. 60 psi max. 3/8" IPS cold water	1 1/2" IPS common drain. Do not connect any other units to this drain.	115V-1PH 25 watts per compartment.	RIGHT = 12.00" If adjoining wall or equipment is over 30.00" high. LEFT = 0" REAR = 0"

SCALE .50" = 1'

Cleveland/ALCO reserves right of design improvement or modification, as warranted.

**SteamPro® XVI**  
**PRESSURE/CONVECTION STEAMER**

MODEL:  9-PCSM-L

- TWO LARGE COMPARTMENTS
- STEAM COIL GENERATOR
- 900mm CABINET BASE

**General Specifications:**

- Pressure or Convection steam cooking. Each compartment independently operational in Pressure or Convection mode, user selectable
- In Convection mode, cooking compartment operates without pressure, permitting door to be opened while cooking continues
- In Pressure mode, door is locked and sealed
- At any time a compartment becomes pressurized, door will automatically lock for safety
- 10 psi operating pressure in Pressure mode
- Solid state, digital timer with wipe clean touch control panel, one per compartment, each with 99 minute capacity plus selectable "Repeat Cycle" feature
- Automatic temperature compensated timing action for consistent product results
- "Clean Cove" corners in cooking compartments — easy to clean
- Solid state controls for boiler and steam flow
- 15 psi safety valve
- Insulated cooking compartments
- Type 304 Stainless Steel: cooking compartments, doors, table top
- Exterior sheathing is type 304 Stainless Steel, #4 finish
- Four Stainless Steel legs with level adjustment
- Serviceable from the front: solid state timers, electrical controls and components, all boiler controls and components, compartment drain lines and steam injection tubes
- Capacity for either 12" x 20" pans or 18" x 26" bun pans
- Single cold water connection
- Boiler empties under pressure (blows down) automatically upon each shut-down, automatic water fill upon start-up
- Standard control panel languages are English, French, and Spanish

ITEM NUMBER \_\_\_\_\_

JOB NAME / NUMBER \_\_\_\_\_



**MODELS AVAILABLE**

Model No.	Description
9-PCSM-L	2 large size compartments, each compartment independently operational in Pressure or Convection mode, user selectable; 900mm (35.43") modular base; steam coil generator.

**Options and Accessories:**

- "California Code" boiler controls compliance kit factory installed.
- Voltages other than standard (115V)
- Cooking pans
- Stainless steel base frame (FSS)
- 8", 10" or 12" adjustable legs

### SHORT FORM SPECIFICATION

Shall be Two Compartments, CLEVELAND Pressure/Convection Steamer, steam coil generator, Model 9-PCSM-L, 115 volts, 60 Hz, 1 phase. Pressure/Convection modes to be selectable at user's option with no restrictions as to any combination of modes. Type 304 Stainless Steel exterior paneling and cooking compartments. Insulated compartments. One solid state, 99 minute digital timer with touch control per compartment. Audible and visual signals for cycle completion and steam shut-off. Separate visual indication for each operational mode.

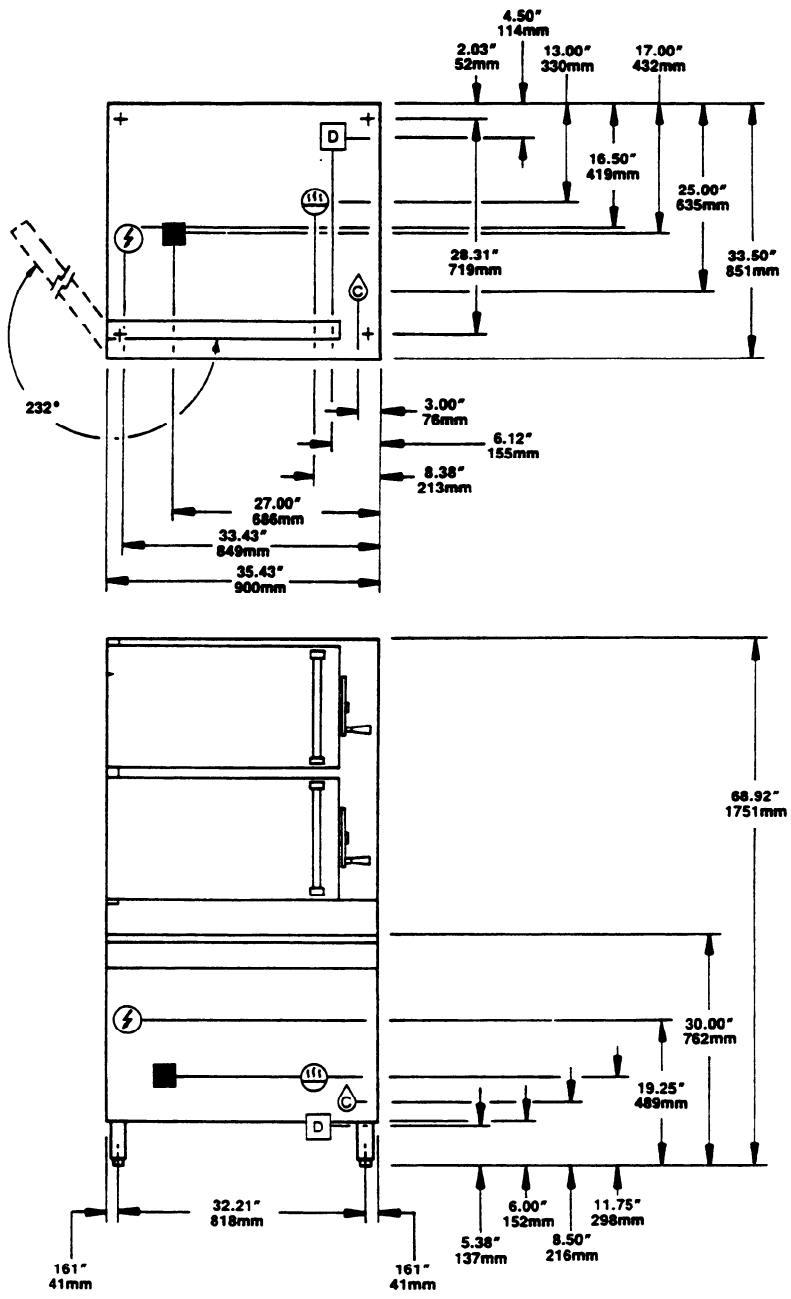

- Each compartment has capacity for:  
Eight, 12" x 20" x 2½" pans.
- Many local codes exist and it is the responsibility of the owner and installer to comply with those codes.
- Cleveland/ALCO equipment is built to comply with applicable standards for manufacturers. Included among those approval agencies are: UL, A.G.A., NSF, ASME/N.Bd., CSA, CGA, ETL, and others.

### WATER QUALITY REQUIREMENT

The recommended minimum water quality standards whether untreated or pre-treated, based upon 10 hours of use per day, and a Daily Blowdown, are as follows:

TOTAL DISSOLVED SOLIDS	less than 60 parts per million
TOTAL ALKALINITY	less than 20 parts per million
SILICA	less than 13 parts per million
pH FACTOR	greater than 7.5

Consult a local water treatment specialist for an on site water analysis for recommendations concerning steam generator feed water treatment (if required), in order to remove or reduce harmful concentrations of minerals. The use of highly mineralized water will mean that more frequent servicing of the steam generator will be necessary. The fact that a water supply is potable is not proof that it will be suitable for the generator.

STEAM COIL (☁)	WATER (💧)	DRAINAGE (D)	ELECTRIC (⚡)	CLEARANCE
Steam Supply Piping: • ¾" IPS min. for 35 to 50 psi. • For pressure above 50 psi, a pressure reducing valve must be specified.	35 psi min. 60 psi max. ¾" IPS cold water.	1½" IPS common drain. Do not connect any other units to this drain. Steam Coil Drain ■ ¾" IPS. Do not connect to common drain.	115V-1 PH 25 watts per compartment.	RIGHT = 12.00" If adjoining wall or equipment is over 30.00" high. LEFT = 0" REAR = 0"

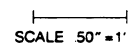

Cleveland/ALCO reserves right of design improvement or modification, as warranted.

## INSPECTION

Before unpacking, visually inspect the shipping carton for evidence of any damage during shipment. If there are signs of possible damage, do not unpack the equipment. Notify the carrier that delivered the shipment so the carton and its contents can be examined for any damage claims. Fill out all appropriate forms and have the examining carrier sign and date each form. Do not install damaged equipment.

## UNPACKING

1. If the shipping carton has no signs of possible damage, unpack the equipment. To remove the unit from the carton, it is easiest to sit the carton in 4 corners and "peel" it away from the steamer. After removing the carton, examine the steamer for signs of possible damage. If damage exists, detail your observations on a claims form and give to the shipper (keep a copy for your records).
2. If the equipment is undamaged, lift the unit to the counter top or stand where it is to be installed. Damaged equipment should not be installed.

## INSTALLATION INSTRUCTIONS

### **WARNING**

*Installation of this unit must be done by qualified plumbing and electrical installation personnel working to all applicable local and national codes. Improper installation of this product could cause injury or damage and void customer warranty.*

### INSTALLATION POLICIES:

- Cleveland/ALCO equipment is designed and manufactured to comply with applicable standards for manufacturers. Included among those certification agencies which have approved the safety of the equipment design and construction are: UL, NSF, CSA, and others.
- Cleveland/ALCO equipment is designed and certified for safe operation only when permanently installed in accordance with local and/or national codes. Many local codes exist, and it is the responsibility of the owner and installer to comply with these codes.
- In no event shall Cleveland/ALCO assume any liability for damage or injury resulting from installations which are not in strict compliance with our Installation Instructions. Specifically, Cleveland/ALCO will not assume any liability for damage or injury resulting from improper installation of equipment, including, but not limited to, temporary or mobile installations.

### INSTALLATION INSTRUCTIONS FOR ALL MODELS:

### **WARNING**

**INSTALLER: ALL SteamPro™ XVI units MUST BE securely anchored to the floor at all times.**

1. These instructions must be retained by the owner/user for future reference. Gas-fired boilers are only to be installed in noncombustible areas that have provisions for adequate air supply. The term "boiler" will be used synonymously with "steam generator".
2. Position: For proper operation and drainage, the equipment must be level. It should be placed next to an open floor drain. **DO NOT POSITION THE UNIT DIRECTLY ABOVE THE FLOOR DRAIN.** Observe all clearance requirements to provide air supply for proper operation, as well as sufficient clearance for servicing. The surrounding area must be free and clear of combustibles. Dimensions and clearance specifications for each model are shown on the specification sheets enclosed.
3. Install in accordance with local codes and/or the National Electrical Code ANSI/NFPA No. 70-1984. Installation in Canada must be in accordance with the Canadian Electrical Code CSA Standard C22.1. Equipment that is connected to electricity must be grounded by the installer. A wiring diagram is provided inside the base cabinet.
4. Attach drain extension piping to the drain connection to carry steam condensate and boiler drain water away from the cabinet, to the floor drain. The drain extension piping must be 1 1/2" diameter minimum (ips), and not exceed 6 feet in length, with no more than two elbows, before draining. The drain extension termination **MUST** vent freely to the air (not plumbed solidly into the floor drain). Each unit requires its own 1 1/2" diameter drain extension. Do not interconnect any other drains to this unit's drain extension. Ensure that the boiler's manual drain valve is closed.

5. Connect COLD water supply plumbing to the line strainer. (Never connect hot water to the boiler's water fill line strainer). Constant flow pressure must be maintained between 40 and 60 psi, and not experience a pressure drop below 35 psi when other appliances are used. If the water pressure exceeds 60 psi, a pressure reducing valve must be installed in the water supply plumbing to reduce the water pressure to less than 60 psi. Locations and pressure data are shown on the specification sheet. 3/8" lps plumbing is required for water supply lines regardless of length. Flush water supply lines thoroughly before connecting them to the unit. Use water which is low in total dissolved solids content and low in gas content to prevent internal scaling, pitting and corrosion of the steam generator and carry-over of minerals into the steam. (Water which is fit to drink can still contain highly detrimental impurities.)
6. Turn on the cold water supply to the unit. Ensure that the manual water valve, inside the base cabinet, is open.
7. Connect the primary fuel supply in accordance with the following instructions. Location and other data are shown on the specification sheet.

#### For Gas-Fired Steam Generators:

Post, in a prominent location, instructions to be followed in the event the user smells gas. This information shall be obtained by consulting the local gas supplier. Install as a sediment trap (drip leg) in the gas supply line, then connect gas supply piping to the boiler's gas valve piping. **GAS-FIRED EQUIPMENT IS DESIGNED FOR INSTALLATION ONLY IN NONCOMBUSTIBLE LOCATIONS.** Location, plumbing size, and pressure data is shown on the specification sheet. Boilers rated at less than 225,000 BTU require 3/4" lps gas supply piping, and boilers rated at 225,000 BTU or more require 1" gas supply piping. Natural gas supply pressure must be between 4"-14" water column and LP gas supply pressure must be between 12" - 14" water column. **NEVER EXCEED 14" WATER COLUMN (1/2 psi) GAS PRESSURE.** If the gas supply pressure exceeds 14" water column a pressure regulating valve must be installed in the gas supply plumbing to reduce the gas pressure to less than 14" water column. Installation must be in accordance with local codes, or in the absence of local codes, with the National Fuel Gas Code, ANSI Z223.1-1984. Installation in Canada must be in accordance with Installation Codes for Gas Burning Appliances and equipment B149.1 and B149.2. Use a gas pipe joint compound which is resistant to LP gas. Turn the gas valve's control knob to "on" (the word "on" on the knob will be opposite the index on the valve's body). Test all pipe joints for leaks with soap and water solution. Never obstruct the flow of combustion and ventilation air. Observe all clearance requirements to provide adequate air openings into the combustion chamber. The appliance and its individual shut off valve must be disconnected from the gas supply piping system during any pressure testing of that system at test pressures in excess of 1/2 psi (14" water column or 3.45 kPa). The appliance must be isolated from the gas supply piping system at test pressures equal to or less than 1/2 psi (14" water column or 3.45 kPa). A permanent 115 volt electrical connection is required at the junction box. Location shown on the specification sheet. The unit must be electrically grounded by the installer.

#### For Electric Powered Steam Generator's:

Connect electric power location and data are shown on the specification sheet. Provide connection as required by your unit; either directly to the single contactor, or to the terminal block (when equipped with multiple contactors). Electric supply must match power requirements specified on the data plate inside the base cabinet. The copper wiring must be adequate to carry the required current at the rated voltage. A separate fused disconnect switch must be supplied and installed. The unit must be electrically grounded by the installer.

#### For Direct-Steam-Connected Steamers:

Connect steam supply piping to the input side of the line strainer. Location and pressure data are shown on the specification sheet. Flush the steam line thoroughly before connecting it to the steamer to ensure an adequate volume of steam, the branch steam supply line must be 3/4" lps minimum. A permanent 115 volt electrical connection is required at the junction box. The junction box location is shown on the specification sheet. The unit must be electrically grounded by the installer.

8. Press the "power" on-off rocker switch. The red indicator light in the switch will come on and the boiler will begin to fill with water. Direct-Steam-Connected steamers are not equipped with self generating boilers or "steam" switches. Therefore, these models do not require the 5 minute boiler water fill time, nor is it necessary to push a "steam" switch to produce steam, as indicated in step #9. As soon as the pressure gauge on the control panel registers 10 psi (5 psi for pressure steamers), preheating may begin. (If you are operating a direct steam-connected steamer, steps #9 and #10 do not apply. Refer directly to step #11.)
9. After about five minutes the amber light in the "steam" switch will glow indicating the water has reached a safe operating level in the boiler. The "steam" switch can now be pressed (momentarily) in order to produce steam in the boiler. This will activate the energy source (electric heaters, gas burners, or steam solenoid valve), and

the amber light will go out. The energy source cannot be activated until the boiler contains sufficient water indicated by the amber light. The "steam" switch must be pushed to re-start the steamer after it is shut off for any reason (including a momentary power interruption). Do not attempt to start or operate this appliance during a power failure. Whenever the amber light is illuminated, the heater, steam supply, or burners are off, and no steam is being generated.

**NOTE FOR UNITS CONTAINING GAS-FIRED BOILERS ONLY:** If the burners fail to ignite in four seconds, a safety circuit will de-energize the system. In this event, momentarily press the power switch to the "off" position, then back to the "on" position. ( The "steam" switch amber light should be on. Wait 5 minutes, then press the "steam" switch to start the burner ignition cycle once again.)

10. Check to ensure that the water in the boiler's sight gauge glass stays at about 2/3 full when the boiler is started up and operated.
11. Check to ensure that the steam pressure gauge registers 10 psi. The steam pressure is factory adjusted to provide the proper pressure in some cases, however the factory setting may shift due to shaking in transit, and resetting will be required after installation. Proper adjustments and maintenance procedures should be made only by qualified service personnel. The factory pressure settings shown in the accompanying chart should never be exceeded.
12. When the installation is complete and free of leaks, refer to the OPERATIONAL FUNCTIONS section, in order to understand proper operation of the unit.

GAUGE PRESSURE READING WITH NO STEAM FLOW (STATIC PRESSURE)								
Equipment	Self-Contained Steam Generator Gas or Electric			Self-Contained Steam Coil Generator			Direct-Connect (To "House" Steam Supply)	
	Steamer's Pressure Reducing Valve	Operating Pressure Switch	High Limit Safety Pressure Switch	Operating Pressure Switch	High Limit Safety Pressure Switch	Steam Supply Pressure Range	Steamer's Pressure Reducing Valve	Steam Supply Pressure Range
Steam Generator Only 5 psi	N/A	5psi	10 psi	5 psi	10 psi	30-45 psi	N/A	N/A
Pressure Steamer	N/A	5 psi	10 psi	5 psi	10 psi	30-45 psi	5 psi	12-45 psi
Pressure Steamer With Any Kettle(s)	5 psi	10 psi	15 psi	5 psi	10 psi	30-45 psi	5 psi	12-45 psi
Steam Generator Only 10 psi	N/A	10 psi	15 psi	10 psi	15 psi	30-45 psi	N/A	N/A
Kettle Only — All	N/A	10 psi	15 psi	N/A	N/A	N/A	N/A	5-45 psi
Convection Steamer With or Without Kettles	N/A	10 psi	15 psi	10 psi	15 psi	35-45 psi	10 psi	15-45 psi

\*Kettles are to be connected to the "house" steam supply.

## INSTALLATION CHECK

Proper operation of the Cleveland SteamPro™ XVI Steamer is dependant upon proper installation. After the steamer has been installed, a few quick checks could save unnecessary service calls.

1. The SteamPro™ XVI Steamer requires a cold water connection for proper, efficient operation. **DO NOT USE HOT WATER.** The cold water must be connected to the line strainer located at the front lower-right of the steamer base. Ensure that the manual water supply valve is open.  
The cold water feed line must maintain 40 to 60 psi constant flow pressure, and not experience a pressure drop when other appliances are used. Both the hot and cold water lines should maintain 35 to 60 psi flow pressure.
2. The unit must be level.
3. On electric units, the supply voltage must agree with the voltage indicated on the rating plate inside the base cabinet, and with the voltage shown on the packing slip. The unit must be protected with a separate fused disconnect and be properly grounded, in accordance with the National Electric Code.

4. On Gas, Steam Coil and Direct-Steam-Connected units, there is a 115 volt connection required at the junction box located in the base at the bottom front.
5. The drain extension termination must vent freely to the air (not plumbed solidly into the floor drain). The drain extension piping must have a gravity flow, be 1 1/2" diameter minimum (IPS), and not exceed 6 feet in length with no more than two elbows before draining. Each steamer requires its own 1 1/2" diameter drain extension. Do not interconnect any other drains to this steamers' drain extension. Ensure that the manual drain valve is closed.

**REMEMBER:** DO NOT POSITION THE UNIT DIRECTLY ABOVE THE FLOOR DRAIN, AS RISING CLOUDS OF STEAM CONDENSATE WILL DAMAGE ELECTRONIC COMPONENTS.

**CAUTION** Failure to comply with these drain instructions could result in the accumulation of hot water in the cooking compartment.

6. On Direct-Connect units the incoming steam pressure must be 35 to 50 psi, and anything less than 35 psi will not effectively operate this unit.
7. Gas-fired steam generators should never exceed a 14" water column or 1/2 psi gas pressure. Gas equipment is designed for installation only in noncombustible locations.

Installer: Please complete and mail the *Installer's Checklist*.

## INTRODUCTION TO SteamPro™ XVI OWNERSHIP

To get the full advantage of steam cooking, your Cleveland/ALCO SteamPro™ XVI must be properly installed. A steamer which is improperly installed, improperly used, improperly maintained or improperly repaired will create a dangerous condition and may cause injury to personnel.

### OPERATIONAL SAFETY:

Your Cleveland/ALCO SteamPro™ XVI will require minimum servicing provided it is operated according to instructions and given the care recommended.

Make sure that responsible personnel understand how your steam cooking equipment should be operated and cared for. Proper use and maintenance pay handsome dividends in long life and satisfactory performance.

Safe steam cooking equipment operation dictates that every owner of steam cooking equipment should follow these rules for operational safety:

- 1) Begin a comprehensive, continuous program of internal and external steam cooking equipment inspection.
- 2) Never allow untrained personnel to operate or experiment with a steamer.
- 3) At the end of each days operation -
  - Remove any spilled food, then wash the racks and compartment interiors thoroughly with mild detergent in warm water.
  - Rinse thoroughly with clean warm water.

### WARNING

*Let rinse water drain through compartment drain opening. If water does not drain freely, drain lines must be cleaned out before cooking again. Clogged or slow drains are dangerous because hot water may collect and spill out when compartment doors are opened after a cooking cycle.*

- When cleaning the steamer's exterior, BE SURE THAT POWER TO THE UNIT IS OFF. Never apply water to controls on the console. Use a damp cloth for cleaning.
- 4) Always leave the compartment door ajar when the compartment is not in use.

- 5) Shut the unit down at the end of each day's operation as follows:
  - On boiler equipped steamers, blow down the boiler. Then refill the boiler with water, and shut off the power switch.
  - On direct connected steamers, cut off the main steam supply with a valve ahead of the steamer's pressure reducing valve.
- 6) Read and follow the Cleveland/ALCO instructions on steamer and steam generator maintenance in the Owners Manual.
- 7) Only allow the use of replacement parts which are factory authorized as equivalent to the parts being replaced, to preserve the certification of Underwriters Laboratories, American Gas Association, Canadian Standards Association or Canadian Gas Association (as applicable).
- 8) Never allow unqualified personnel to tamper with the steamer or steam generator controls, or to replace worn out parts.

**FOR YOUR SAFETY**  
 Do not store or use gasoline or other flammable vapors and liquids in the vicinity of this or any other appliance

- 9) For gas fired steam generators (boilers): Post in a prominent location instructions to be followed in the event the user smells gas. This information shall be obtained by consulting the local gas supplier.
- For additional information on steamer safety, refer to the steamer operating procedure on page \_\_\_\_\_  
 Instructions for the occasional servicing that will be needed are given on pages 15-19. Servicing beyond these instructions should not be attempted without specialized skills and experience. Such attempts may void the warranty on the equipment.

## OPERATIONAL FUNCTIONS

Operation of the Cleveland SteamPro tm XVI is very easy. Each operator should become familiar with the following operation functions and procedures to effectively start, operate and shut down the steamer.

**CONTROL PANEL OVERVIEW:** \_\_\_\_\_

**CAUTION** The touch pad controls are designed to be pressed with finger tips only. Be careful not to use finger nails, kitchen utensils or anything that could cause damage.

**"DIGITAL TIME DISPLAY"** - Time programmed in the Pressure or Convection mode will be displayed here in red numbers. A maximum of "99" minutes can be programmed. During operation, time displayed will countdown to "00". "00" will blink until the compartment door is opened. (When using the Manual mode, time displayed will stay at "00". The Timer is not used in this mode.)

**"TIMER TOUCH PANEL"** - "Number" touch pads are used to program the desired cooking time for Pressure or Convection mode. The Time entered will be shown in the DIGITAL TIME DISPLAY

**"START/CANCEL"** - Press this touch pad once to START the compartment operational mode process. The green indicator light (LED 1) will come on and stay on until the touch pad is pressed again to CANCEL. When the compartment temperature reaches 194°F (in either Pressure or Convection mode) the green indicator light (LED 2) will come on and start flashing until countdown is completed. START/CANCEL is not used when in "Manual Operation" mode or TIMER BYPASS function.

**"PRESSURE OPERATION"** - Press this touch pad to change from the Convection mode to the Pressure mode. The red indicator light (LED 3) will come on and stay on until the steaming cycle is completed, the compartment is depressurized (the "LOCKED" symbol will go out) and the compartment door is unlatched. **WARNING:** At the end of a Pressure mode steaming cycle, wait at least 2 minutes for the compartment to depressurize and drain before opening the compartment door. Premature opening can result in steam or hot water burns.

**"MANUAL OPERATION"** - Press this touch pad to operate the compartment in the Convection mode but without the use of the START/CANCEL touch pad, the TIMER TOUCH PANEL or the DIGITAL TIME DISPLAY. The green indicator light (LED 4) will come on and stay on until the touch pad is pressed again.

**"COMPARTMENT PRESSURE"** - Use this gauge to monitor the compartment pressure.

**WARNING** Open the compartment door only when the Pressure Gauge returns to "0" PSI. If the gauge does not indicate "0" PSI, do not attempt to pull up on the compartment latch handle or to open the compartment door. The unit must be serviced by qualified personnel.

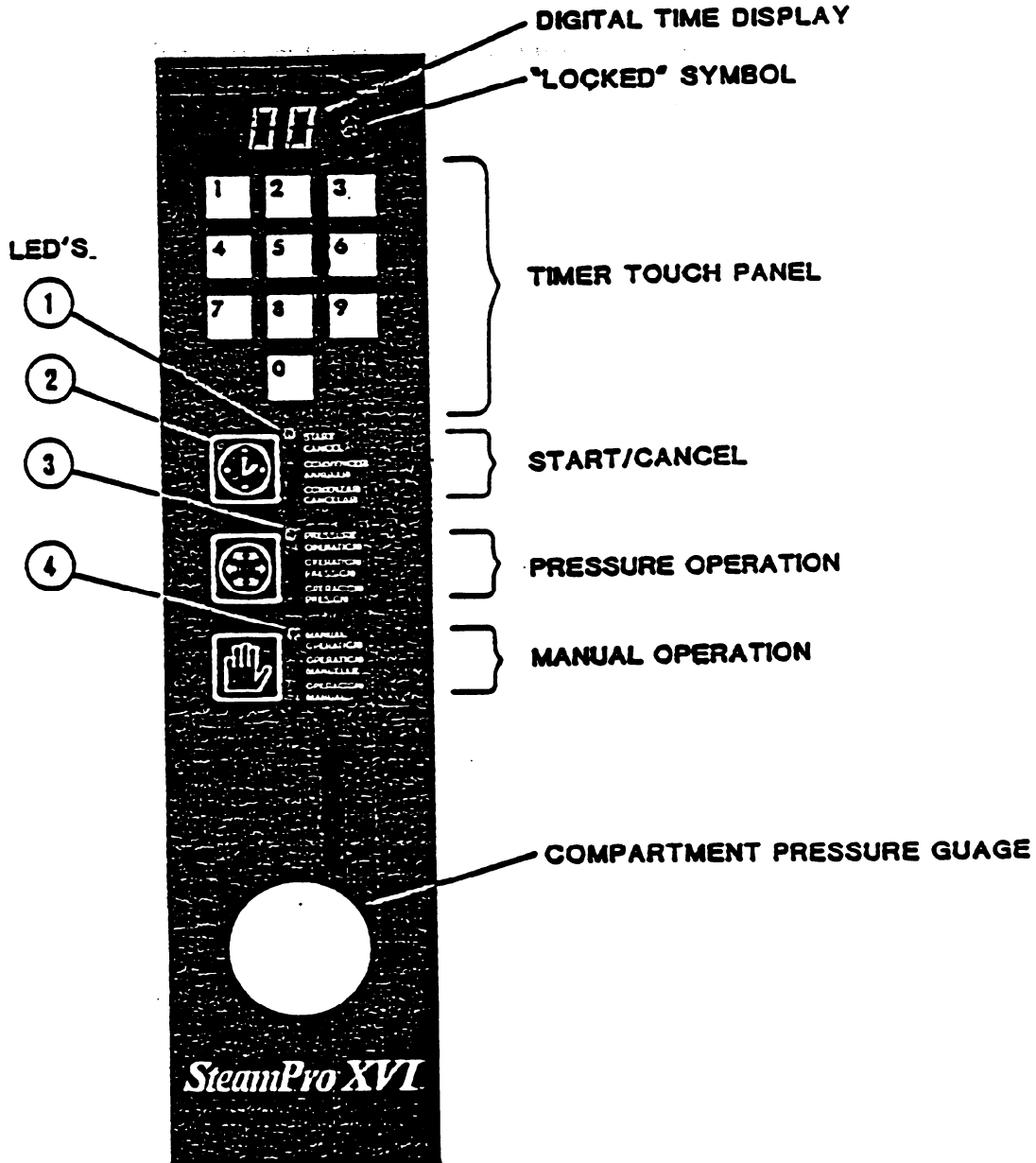

### TIMER INFORMATION

Each cooking compartment is equipped with an independent electronic digital timer, which has a maximum programming capability of 99 minutes. Each timer is connected to a temperature sensing device the cooking compartment. This sensor will allow the timer to count down only when the internal compartment(s) reaches proper cooking temperature. This assures uniformity in the final product as the timer automatically compensates for the amount and temperature of the food in the compartment.

## TIMER SETTINGS (Programming)

Press the "Start/Cancel" touch pad once to ensure that no time remains in the timer. Program the desired cooking time by pressing the appropriate number pads. The time programmed will be displayed above the "Number" touch pads. Example, pressing the "1" pad, then the "2" pad programs 12 minutes.

Press the "Start/Cancel" pad to start the timer. This starts the flow of steam into the cooking compartment. Remember the timer will begin to count down only after the compartment reaches proper cooking temperatures. After the programmed time has counted down to zero, an alarm will sound for 5 seconds and steam flow (into the cooking compartment) will stop. In "Manual Operation" mode, the steamer operates as a Convection steamer only.

The timer must be programmed and started before steam will begin to flow into the selected steaming compartment whether in Pressure or Convection mode.

In either Pressure or Convection mode, the desired cooking time must be programmed into the timer and the "Start/Cancel" touch pad must be pressed (to begin the flow of steam). The timer will delay its' countdown, automatically compensating for defrosting and/or food product heat-up time. Example: If you have programmed the timer at 10 minutes, it may in fact take 11 or 12 minutes for the programmed time to expire and the signal to sound. This is normal. The additional time was used to heat the compartment and to remove the air. When the timer counts down to zero, the Digital Timer Display will flash, a signal will sound and the steam flow to the cooking compartment will shut-off. To stop the Digital Timer Display from flashing, press "Start/Cancel" touch pad once. (The signal will also sound when the compartment is heated to announce the beginning of the timer count down.)

## COMPARTMENT DOOR LATCH/LOCK INFORMATION

### Latching:

The door handle/latch are positive and offer some resistance to movement. This is normal. Also, note that latching the door is a two (2) step movement. Be sure to latch completely into the second step, otherwise the unit will not operate.

### Unlatching:

In the Convection mode, the door is never "Locked" and can be unlatched and opened at anytime. If the door is opened during the cooking cycle for food seasoning or inspection, keep your hands out of the steaming compartment to prevent burning them. Use hot pads when removing pans from compartment. Steam will still flow into the compartment when the handle is in the down, latched position, regardless of whether the door is closed or open. Steam flow stops when the handle is unlatched.

To open the compartment door, partially unlatch the door. If some water comes out of the compartment, or off the door, allow it to finish dripping before completely unlatching and opening the door.

### Locking/Unlocking:

In the Pressure mode, the "Locked" symbol will be illuminated, indicating that the door latch is locked and cannot be opened. Only when the "Locked" symbol is no longer illuminated and the steaming compartment depressurized can the door be unlatched and opened.

## BASIC SEQUENCE OF OPERATION

### CONVECTION STEAMING MODE

---

1. User programs desired steaming time (0 to 99 minutes) via numeric keypad.
2. Compartment door is closed and latched.
3. Cycle is started by pressing "Start/Cancel" touch pad.
4. Steam is introduced into compartment via steam distribution tubes.
5. Steaming begins.
6. Compartment temperature rises to 194°F.

7. Countdown timing begins. Audio signal sounds for 1 second. Countdown indicator (LED2) begins flashing.
8. "Timer" counts down to zero. Alarm sounds for 4 seconds.
9. User presses "Start/Cancel" touch pad. Digital Time Display stops flashing.
10. End of Cycle.

## PRESSURE STEAMING MODE

---

1. User programs desired steaming time (0 to 99 minutes) via numeric keypad. Pressure mode is selected by pressing "Pressure Operation" touch pad. Mode indicator (LED2) lights.
2. Compartment door is closed, latched and automatically locked.
3. Steaming cycle is initiated by pressing "Start/Cancel" touch pad. Indicator (LED1) lights.
4. Steam is introduced into compartment via steam distribution tubes.
5. Steaming begins.
6. Compartment temperature rises to 194°F.
7. Countdown timing begins. Audio signal sounds for 1 second. Countdown indicator (LED2) begins flashing.
8. Pressure begins to build in compartment.
9. Steaming continues at 10 psi pressure. Timer counts to zero.
10. Digital Timer Display begins to flash. Touch pad panel indicators (LED's 1, 2 and 3) turn off.
11. Steam flow stops.
12. Compartment releases pressure.
13. Compartment door is automatically unlocked.
14. User presses "Start/Cancel" touch pad to cancel mode.
15. End of Cycle.

## START-UP AND PREHEAT

**CAUTION** Do not attempt to start or operate this appliance during a power failure.

1. Check the cooking compartments to ensure that the steam tubes and drain screens are in place and secure. On steamers equipped with self-contained boilers, check inside the steamers' base cabinet to ensure that the manual drain valve is closed and the manual water supply valve is open.

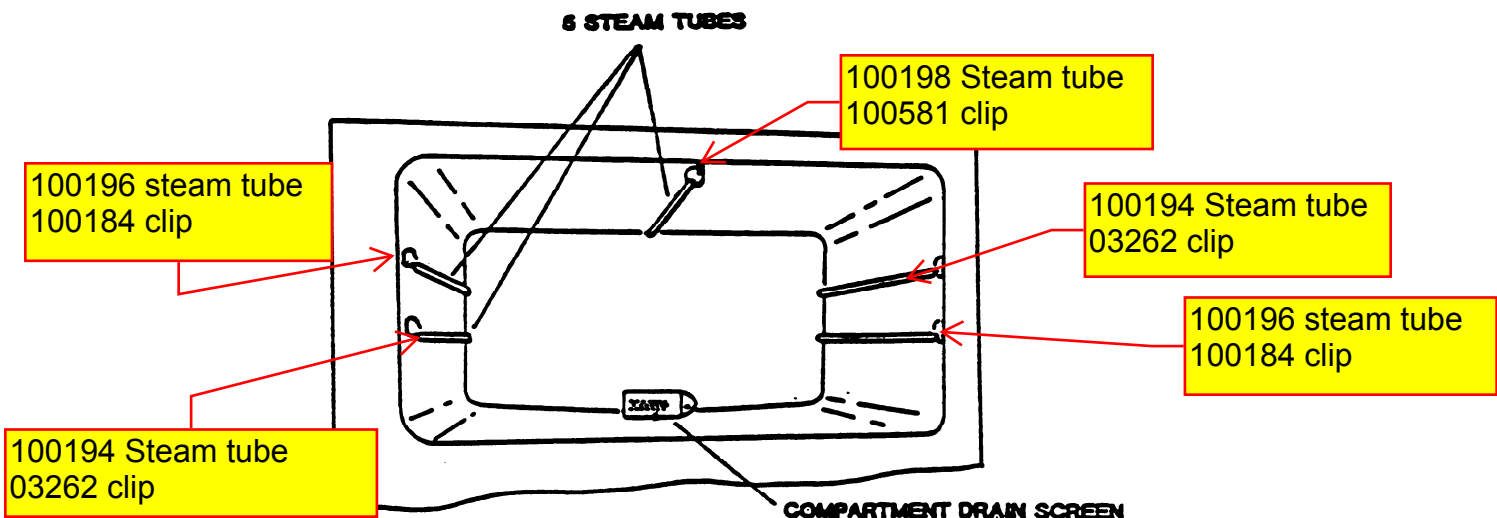

2. Press the red "power on-off" rocker switch located near the steam pressure gauge, at the right side of the base cabinet console. The red indicator light in the switch will come on and the boiler will begin to fill with water.

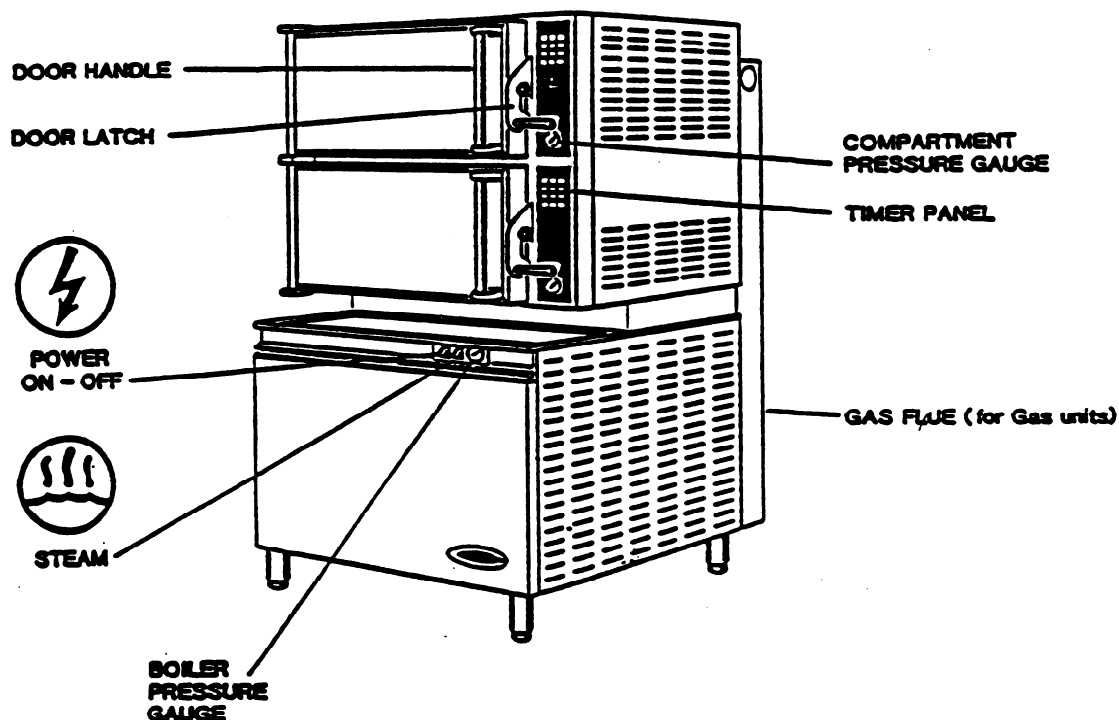

Direct-steam-connected steamers are not equipped with self generating boilers or "steam" switches. Therefore, these models do not require the 5 minute boiler water fill time, nor is it necessary to push a "steam switch" to produce steam, as indicated in step #3 below. As soon as the pressure gauge on the control panel registers 10 psi, preheating may begin. (If you are operating a direct-steam-connected steamer, "skip" step #3, and refer directly to step #4.)

3. After three to five minutes, the amber light in the "STEAM" switch will glow, indicating the water has reached a safe operating level in the boiler. The "STEAM" switch can now be pressed (momentarily) in order to produce steam in the boiler. This will activate the energy source electric heaters, gas burners, or steam solenoid valve), and the amber light will go out. The energy source cannot be activated until the boiler contains sufficient water, indicated by the amber light. The "STEAM" switch must be pressed to re-start the steamer after it is shut off for any reason (including a momentary power interruption). No attempt should be made to operate the equipment during a power failure. Whenever the amber light is illuminated, the heaters, steam supply, or burners are OFF and no steam is being generated.

**NOTE FOR STEAMERS CONTAINING GAS-FIRED BOILERS ONLY:** If the burners fail to ignite in four seconds, a safety circuit will de-energize the system. In this event, momentarily press the power switch to the "off" position, then back to the "on" position. The "STEAM" switch amber light should be on. Wait 5 minutes, then press the "STEAM" switch to start the burner ignition cycle once again. In about 20 minutes the steam pressure gauge on the control panel should register 10 psi.

4. You can now preheat the cooking compartment(s). Cooking compartments should always be preheated before cooking.
5. To preheat, close and latch the compartment door securely. Set the Digital Timer Display for one minute. It will be several minutes before the time display counts down. When the preheating is completed, the steam will automatically shut off and a five second signal will sound.
6. Your steamer is now ready to begin a Steaming Operation.

## PREVENTATIVE MAINTENANCE

**BOILER SHUTDOWN:** (Applies only to steamers which have a self-contained boiler).

The red-lighted power switch must be shut off for 3 minutes every 8 hours to automatically drain highly mineralized water from the boiler (which reduces the formation of scale). See step 1 below.

### DAILY CLEAN-UP:

Your Cleveland SteamPro™ XVI Steamer, must be cleaned regularly to maintain its fast, efficient cooking performance, and to ensure its continued safe, reliable operation.

1. The boiler must be drained (blowdown) daily, or after maximum of 8 hours of use. If the boiler's feedwater contains more than 300 parts per million to total dissolved solids, the boiler must have a blowdown two or three times daily. "Blowdown" means draining the boiler while under pressure.

The boiler "BLOWDOWN" is performed by simply shutting off the steamers' red-lighted "POWER" switch while the boiler is at normal 10 psi operating pressure. When the bottom of the "POWER" rocker switch is pushed, its' red light goes out, and the drain valve automatically opens, draining the boiler. An automatically timed drain water condenser will flush the drain for 3 minutes, then shut off. The steamer is then again ready for use.

When steam is produced, the water in the boiler is being distilled. During this process, the minerals that come into the boiler with the water remain in the boiler as the water boils away as steam. When allowed to accumulate, the water becomes highly mineralized, which results in erratic operation, lime build-up corrosion, and premature failures. In some cases, complete boiler replacement becomes necessary, which is extremely expensive. By draining the boiler under pressure, most sediment present will be flushed down the drain.

2. The steamer is equipped with a drain screen in the back of each cooking compartment. No compartment should be operated without its' drain screen in place. This screen prevents large food particles from entering and possibly plugging the drain line. Any restriction of the drain line will cause an accumulation of hot water in the cooking compartment, which could cause injury when the door is opened. It also may adversely affect the convection action of the steam in the compartment, which is critical to optimum performance. Pouring USDA approved drain cleaner through the compartment drains once a week will help to ensure an open drain. A manual (hand crank) drain auger, or "snake", may be safely used to clear obstructions in the compartment drains. Do not use a power auger, as damage to the plastic drain system may result.

**CAUTION** *With the steamer off, open the cooking compartment door(s) and allow the steamer to cool before cleaning the cooking compartment(s) and their components.*

3. At the end of each day's operation, wash the pan slide racks, drain screens, door gaskets, and compartment interiors with mild detergent and warm water, either by hand or in a dishwasher. Rinse water should drain freely through the compartment drain openings. If it does not, the drain must be cleaned before using the steamer.
4. Always leave compartment door opened a little when not in use to prolong gasket life.

### WEEKLY CLEAN-UP:

1. Once a week, remove the steam tubes and clean the orifices. First remove the pan slide racks by lifting upward and toward the center of the compartment. Pressing backward on the steam tube will allow its' front eyelet to clear the compartment stud. The tube is then angled toward the center of the compartment just enough to clear the stud and be pulled forward, out of its socket. The orifices can be cleaned easily with a paper clip. Then, thoroughly wash and rinse all steam tubes. This can be done in a dishwasher. Lubricate each tube's open end with cooking oil before replacing in the steamer's compartment. Be sure all the steam tubes are securely in place before activating the compartment. The tubes are interchangeable and may be placed in any spot in either compartment.

### EXTERIOR CLEAN-UP:

**WARNING** *Always turn off power to equipment before using water to wash equipment.*

1. Allow steamer to cool before washing. Use the same cleaners and cleaning procedures as for other kitchen surfaces of stainless steel or aluminum. Mild soapy water, with a clear water rinses, is recommended. Do not allow water to run into electrical controls.

**EXTENDED MAINTENANCE:**

A qualified serviceman should be contacted for routine Preventative Maintenance.

1. Periodic boiler inspections should be made by a qualified serviceman.
2. Once every three months the cold water line strainer should be cleaned.
3. The "blowdown" procedure will not completely remove the mineral deposits that adhere to the top of the boiler. A chemical descaling should be done by a boiler treatment specialist. This should be done once a year in average water conditions, but in poor-water areas it may be needed two or three times a year.

Do NOT hose down  
the Steamer!



YOU ARE ENTITLED TO A

**FREE**

DEMONSTRATION OF THIS EQUIPMENT  
TO ASSURE OPTIMUM USE AND  
PERFORMANCE AND TO ENSURE  
THE PROPER UNDERSTANDING  
OF YOUR EQUIPMENT WARRANTY.



YOUR CLEVELAND RANGE  
REPRESENTATIVE IS

Cleveland/ALCO supports a worldwide network of Maintenance and Repair Centers, which are regional distributors of parts and service. Contact your nearest Maintenance and Repair Center for the name of an authorized service agency in your area, or for replacement parts, or information regarding the proper maintenance and repair of your equipment. In order to preserve the various agency safety certifications (UL, A.G.A., CGA, NSF, ASME/Ntl. Bd., etc.), only factory-supplied replacement parts should be used. The use of other than factory-supplied replacement parts will void the warranty.



# CLEVELAND RANGE COMPANY

## THE CLEVELAND CONVECTION STEAMER™ TIMER SETTINGS

Timer settings are approximate due to the differences in food quality, age, shape and the degree of "doneness" desired. It is not necessary to add water. Perforated pans are recommended. Starred items (\*) must be cooked in solid pans or containers. Items marked with two stars (\*\*) require handling in two steps. First, steam for approximately ½ the time shown, remove from steamer, separate thawed portion, or stir, and return to the steamer for the time remaining. The compensating feature of the timer allows the cooking compartment to reach cooking temperature before the preset time starts to count up.

VEGETABLES:	MINUTES		SEAFOODS: Steam all seafoods on a perforated pan with catch pan.	MINUTES	
	Fresh	Frozen		Fresh	Frozen
Artichoke	12				
Asparagus, spears	4	6			
Beans, green 2" cut	6	5	Clams in shell	3-5	
French cut	4	5**	Cod filets, 5 oz. portions	3	4
whole	6	4	Crab legs, king		4-6
Broccoli, spears	3	2-3	Snow crab		2-4
flowerettes	2-3	1-2	Crab, live, 4 oz.	4	
chopped		6-8	¾ - 1 lb.	12	
Brussels sprouts	4-5	4	Halibut, 6-8 oz. portions	4-6	6-8
Cabbage,			Lobster, whole, 1 lb.	7-9	
12-16 wedges/head	4		Lobster tails, 8 oz.		8-10
Cabbage,			defrosted, butterflied		4-6
whole - to remove leaves	2		Mussels in shell	2	
for cabbage rolls			Oysters in shell	2-4	
Carrots, baby whole	10	6	Red snapper, 8 oz.	4-5	4-5
sliced, crinkle cut	7-8	3	Salmon steak, 8 oz.	6	7
diced		2	Shrimp, 10 ct. per lb. IQF	3	4-6
Cauliflower, flowerettes	4-5	3-4	5 lb. block, peeled &		
whole	10		deveined 30 ct.		6-8**
Celery, diagonal cut 1½"	3		5 lb. block, green, 26-30 ct. (nested pan)		10**
diced	2	1			
minced	1		EGGS: Medium Sized		
Corn, yellow whole kernel		2	Hard cooked for egg salad,		
on cob, cobbettes	6	12**	potato salad	10-12	
Eggplant, sliced, diced	1		Soft cooked	3	
Mixed vegetables		3-4	Coddled	6	
Mushrooms, whole (1½" dia.)	3		Poached in a cup	2-3	
sliced	1		Scrambled*	6-7 **	
Onions, diced, sliced	2-3	1			
whole	4	2	FRUITS:		MINUTES
Peas, green		2	Blanch for peeling		
Potatoes, whole 8 oz.	30-35		Fresh: Avocado		1
peeled, quartered, fresh	12-19		Apple, cored		1
peeled, diced	8-10		Grapefruit		1
Potatoes, sweet, whole	30-35		Orange		1
Spinach leaf	2	21**	Apricot		1
chopped		21**	Pineapple, whole		2
Squash, acorn halves	15		Dried*: add water to re-hydrate		
butternut, quartered	7		Apple		10
whipped*		20**	Apricot		10
spaghetti squash, halves	15-18		Peach		10
Tomatoes, whole, sliced*	1		Pear		10
Turnips, whole	20-25		Prune		10
Zucchini, sliced	2-4	2-4			

# CLEVELAND RANGE COMPANY

## THE CLEVELAND CONVECTION STEAMER™ TIMER SETTINGS

(Continued)

### MEATS & POULTRY:

Steam meats and poultry in nested pans, as juices can be used for gravy, sauces, beef stock and soups. The size of portion, thickness of cut, grade, should be considered when selecting a timer setting for doneness.

	MINUTES	
	Fresh	Frozen
<b>POULTRY:</b>		
Turkey, whole	6-8 min./lb.	6-8 min./lb.
Chicken, 5-8 oz. breaded pieces	18-20 min.	
halves, 1¼ - 1½ lb. per half	20-24 min.	20-24 min.

### PORK, SAUSAGE, HOT DOGS:

Pork, Chop, 4 count/lb.	10
Italian sausage, 4 oz. portion	10
Ribs, 3 lb. and down	20-26
Hot dogs, 8 count/lb.	2

### BEEF:

	Fresh	Frozen
Cubes, 1½"	6-7 min./lb.	6 min./lb.
Ground chuck for chili	4 min./lb.	4-6 min./lb.
Pot roast, choice	8-12 min./lb.	
Rump roast, choice boned, rolled, tied	12 min./lb.	
Meat loaf, 4 lb. loaf	5 min./lb.	
Liver, baby beef, 8 oz. slice	2-4	2-4
Comed beef, 6-8 lb. cut, add ½" water to pan	20-23 min./lb.	

### STEAKS

Using a ¾" to 1" steak, the steaming time listed below produces a "rare" steak. A "well done" steak is first steamed to the "rare" stage, then broiled or grilled for 1½ minutes on each side. This "well done" steak shrinks less, is more tender and juicy, and, when served, is the same size as the "rare" steak.

	MINUTES
Sirloin patties, chopped 8 oz.	4
Rib eye, 8 oz.	4
Top butt steak 6 oz.	4
8 oz.	6
Filet Mignon, butterflied —	
4 oz.	3
6 oz.	3-4
8 oz.	4
10 oz.	5
16 oz. whole (Chateaubriand)	8

Strip steak — 10 oz.	5
12 oz.	7
T-bone — 12 oz.	5
16 oz.	8
18 oz.	8
22 oz.	10

	MINUTES	
	Fresh	Frozen
<b>PREPARED ENTREES:</b>		
Full size pans		
Cabbage rolls, stuffed* cover with tomato sauce & serve	25	20
Casserole dishes*		
beef stew,	20-25	25-30
stroganoff	20-25	25-30
Lasagna*, freshly prepared reheat each serving 4"	20-25	25-30
	6-8	12

### DEHYDRATED FOODS:

Potatoes\*: 2½# random sliced plus 5 cups cold water/lb. 12

### RICE & BEANS

Rice*, long grain 4 cups cold water/lb.	17
Beans*, pre-soaked overnight, 1 lb. beans + 1¼ qts. water	45
Beans*, unsoaked, 1 lb. beans, + 1½ qts. water	2½ hrs.
Refried beans*, 2 #10 cans	15-17

### PASTA:

Steam in nested pans. Place pasta on 2½" perforated pan used as a liner in a solid 2½" pan. Cover pasta with cold water.

	MINUTES
Egg noodles, ½" wide	4-6**
Lasagna noodles	10-12**
Macaroni, shells, elbow	10-12**
Rigatoni	10**
Spaghetti, vermicelli	8**
Spaghetti, regular	10**

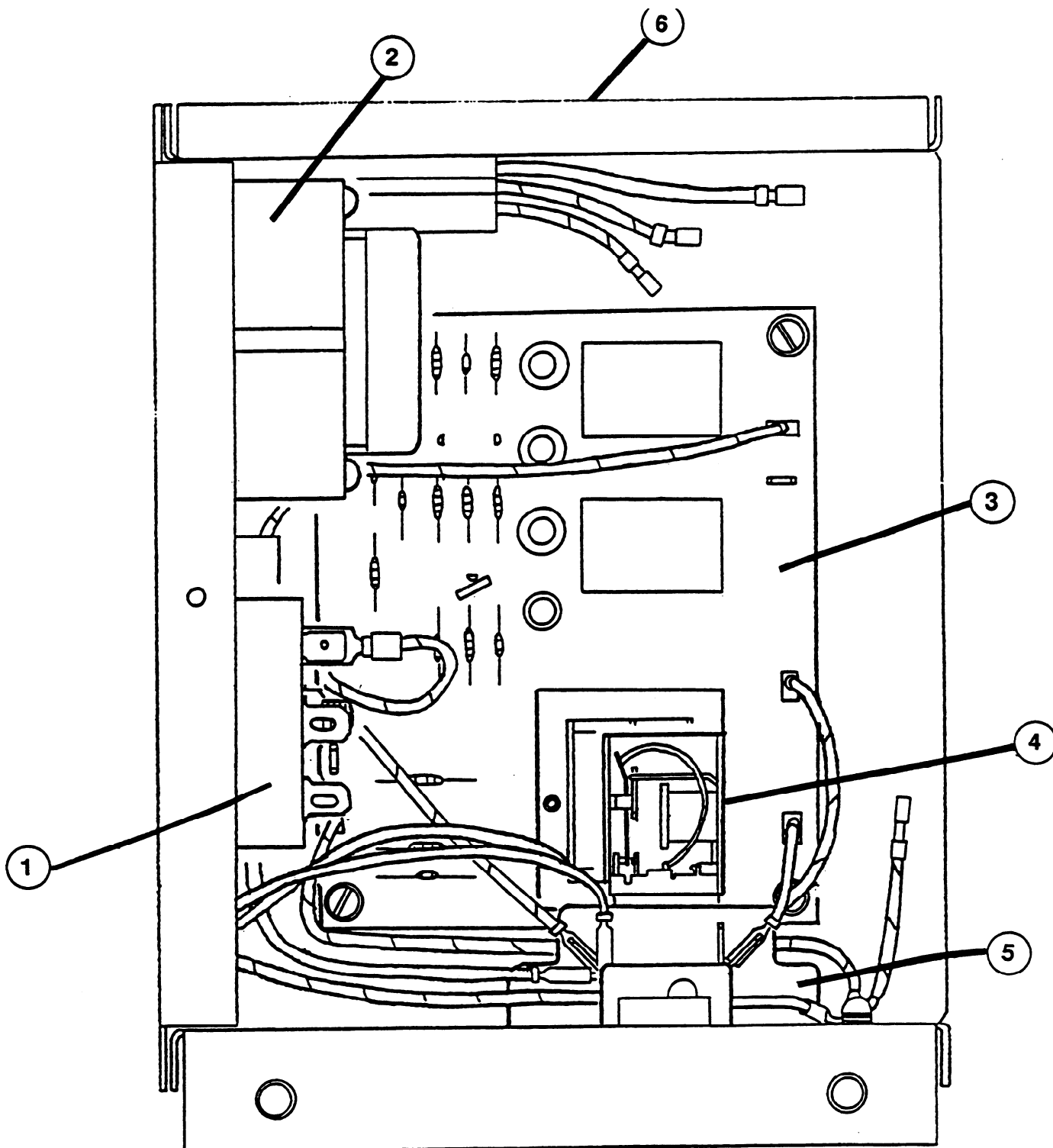

**Electrical Box Assembly  
For Two Probe Gas Generator**

- |    |       |   |
|----|-------|---|
| 1. | 20478 | Timer, Solid State Interval - 3 Minute    |
| 2. | 20528 | Transformer - Spark Ignition Supply       |
| 3. | 23198 | Control Water Level                       |
| 4. | 03524 | Relay, 120 V, 50/60 HZ, AL, DPDT          |
| 5. | 03525 | Socket, Relay                             |
| 6. | 44163 | Box-Electric Assembly - For Gas Two Probe |

# Power Supply

100766 – Power Supply Board

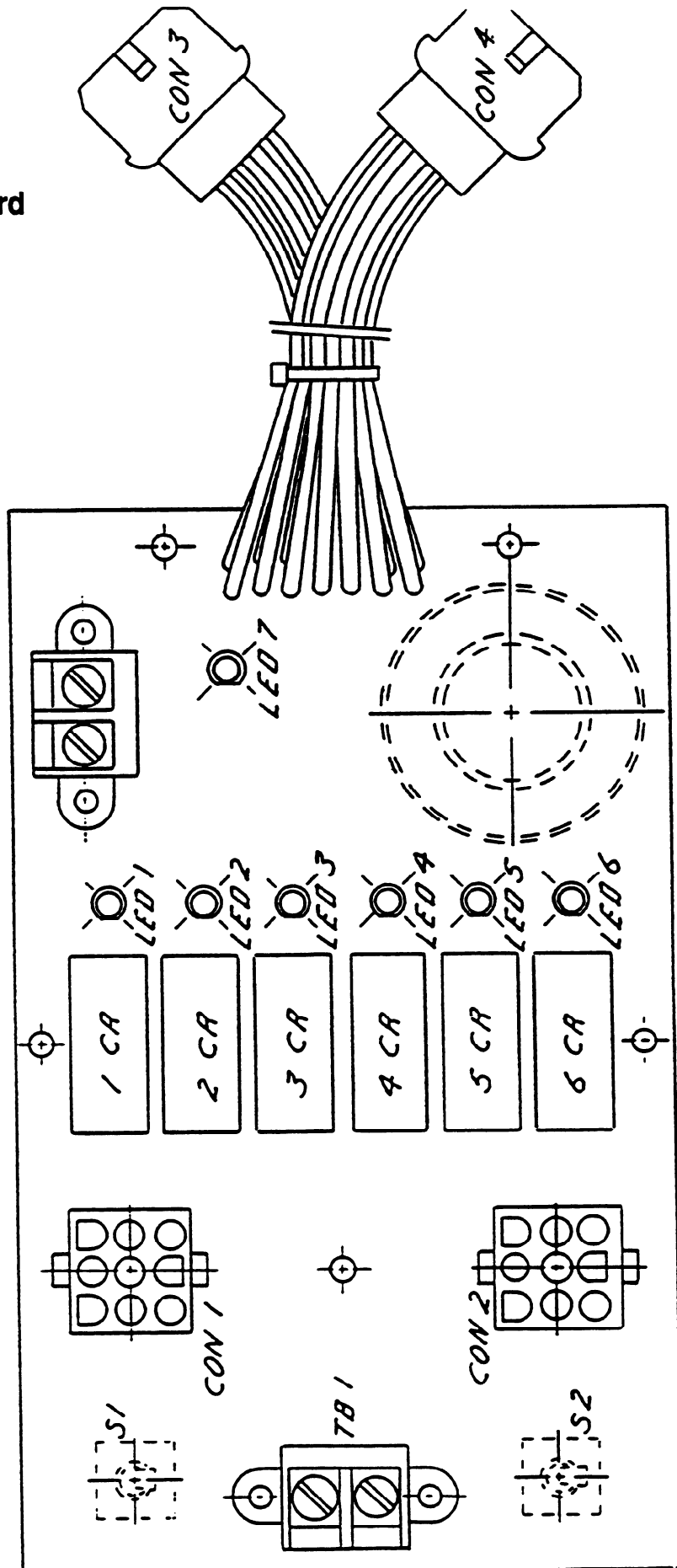

### Timer Panel Assembly

- 1. 1007641 Panel Assembly, Instrument
- 2. 100765 Timer Assembly, Complete
- 3. 14704 Nut, 6-32, Plastic
- 4. 100277 Gauge, Pressure-30" Vac., 30 psi

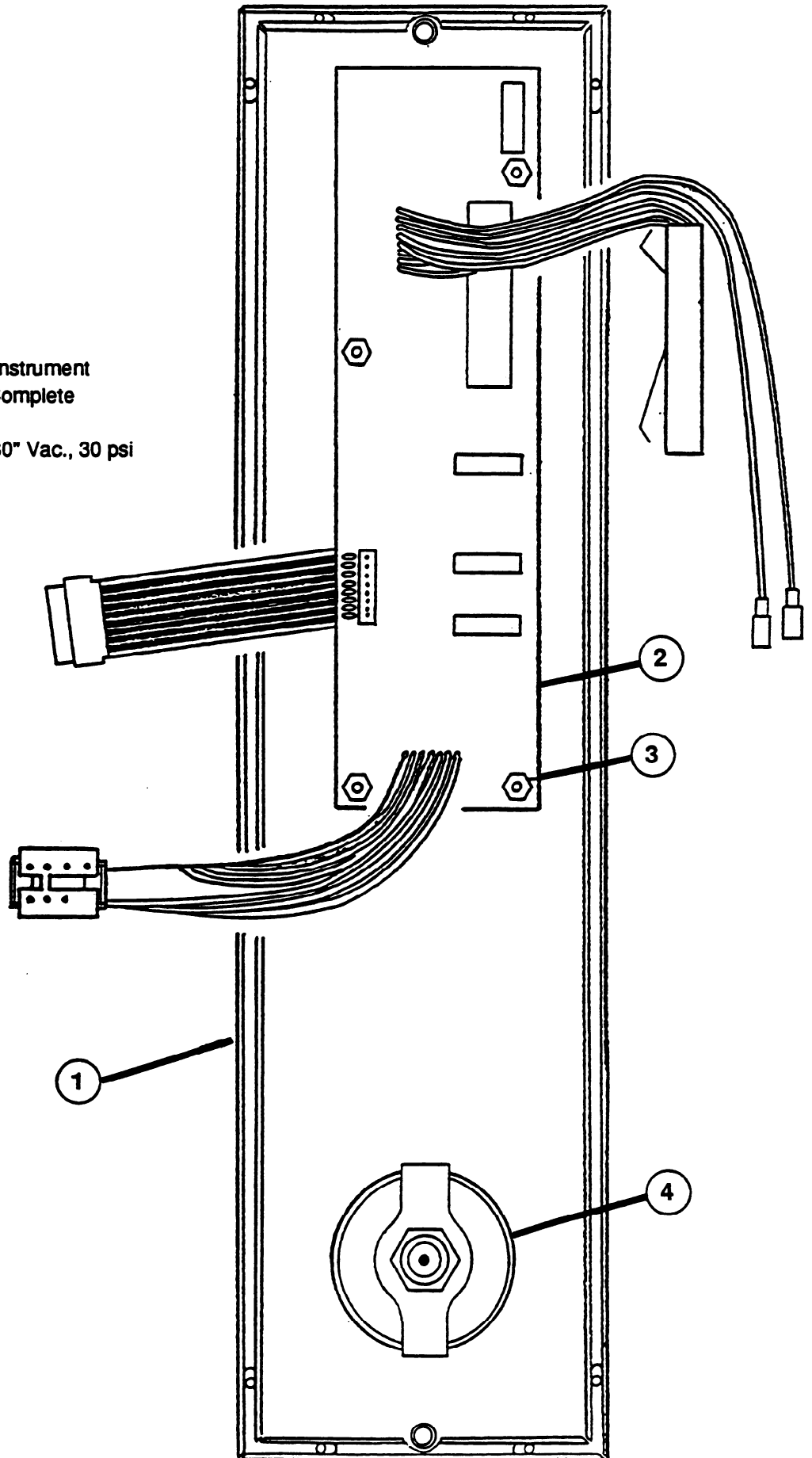

1. 44169 Cable Ignition Asm.
2. 03546 Control Module, Direct Spark Ignition, 4 Second
3. 02361 Box, Handi-Box Electrical, 4 1/8" x 1 13/16" #180-1/2
4. 66037 Cover, Elect, Box Generator, 2 Probe
5. 44164 Terminal Block Assembly - 4 Pole Gas Units
6. 44163 Box - Electric Assembly - For Gas 2-Probe

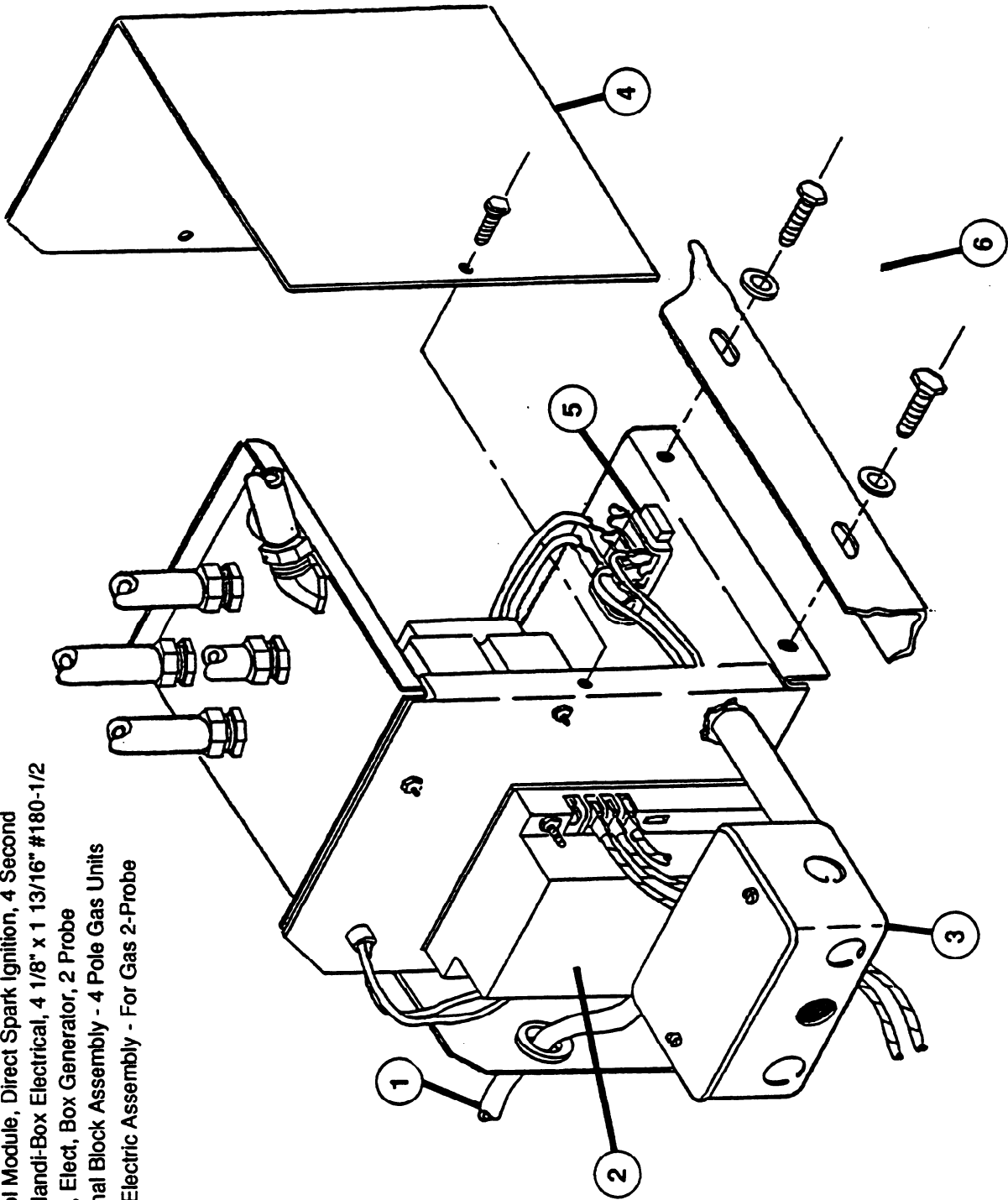

**Electrical Box Assembly  
For Two Probe Gas Generator**

## Latch Assembly

- |    |                  |  |
|----|------------------|--|
| 1. | 450821           | Plate, Weldment - Latch Mount PCL/PCS HL                       |
| 2. | 44148            | Pawl Assembly - PCS/PCL - HL                                   |
| 3. | 100771           | Solenoid, 120 Vac., 60 HZ, Continuous Duty, Class F Insul      |
| 4. | 100768           | Cylinder, Pressure Lock  |
| 5. | 19972            | Switch, Thermal Close 193 + 5 Deg. F, Open 173 + 5 Deg. F, PCI |
| 6. | 100710           | Sprint, Cam Arm Return   |
| 7. | <del>46026</del> | Handle Assembly  |
| 8. | 101524           | Cam/Arm Assembly - PCL/PCS - HL                                |
| 9. | 45084            | Latch Assembly, Door-PCL/PCS - HL                              |

106236

SPRING 101015  
U BRACKET 101013  
PIN 101012  
WASHER 109963

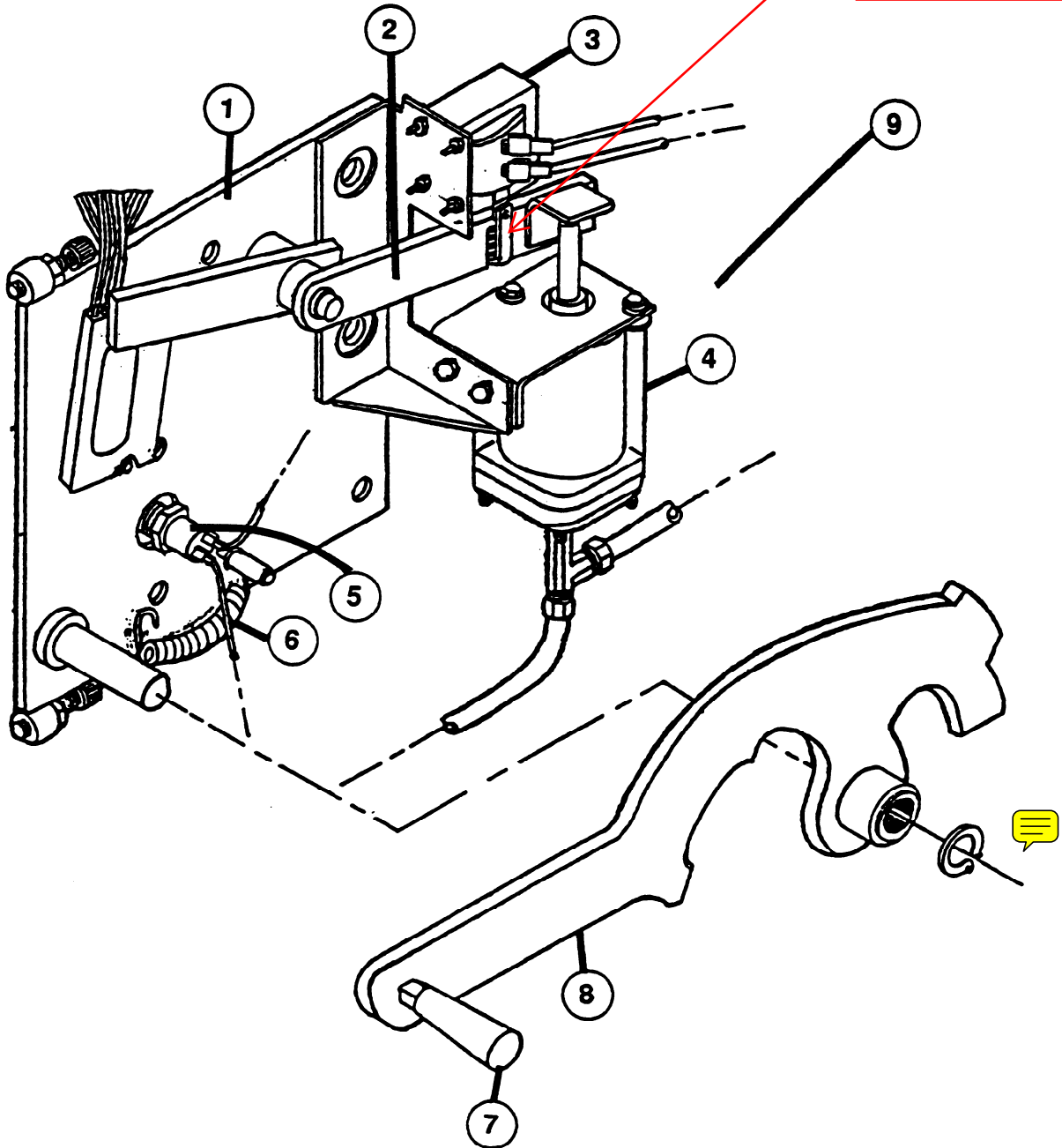

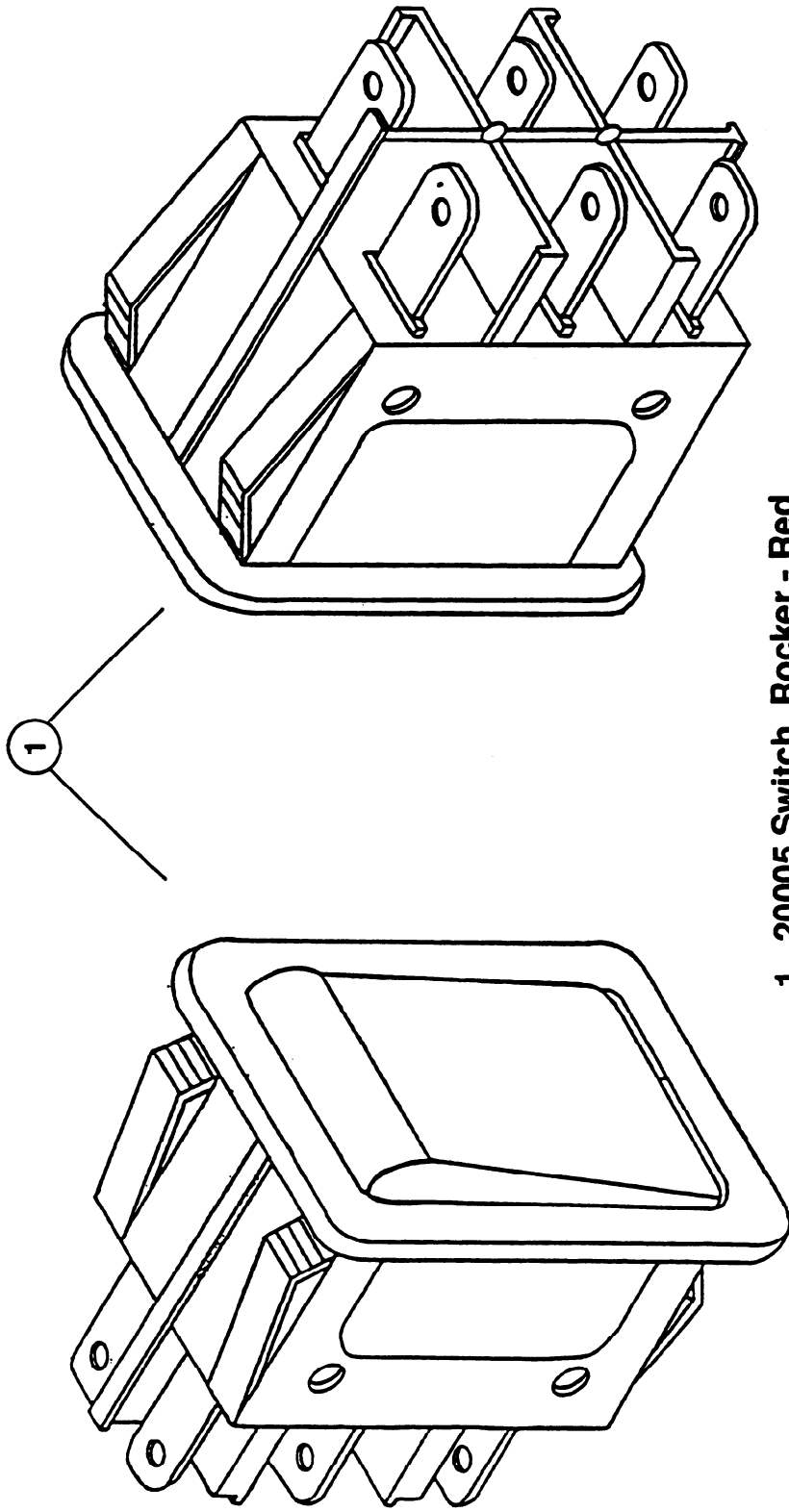

1. 20005 Switch, Rocker - Red

1. 19972 Switch, Thermal Close 193 + 5 Deg. F, Open 173 + 5 Deg. F, PCI

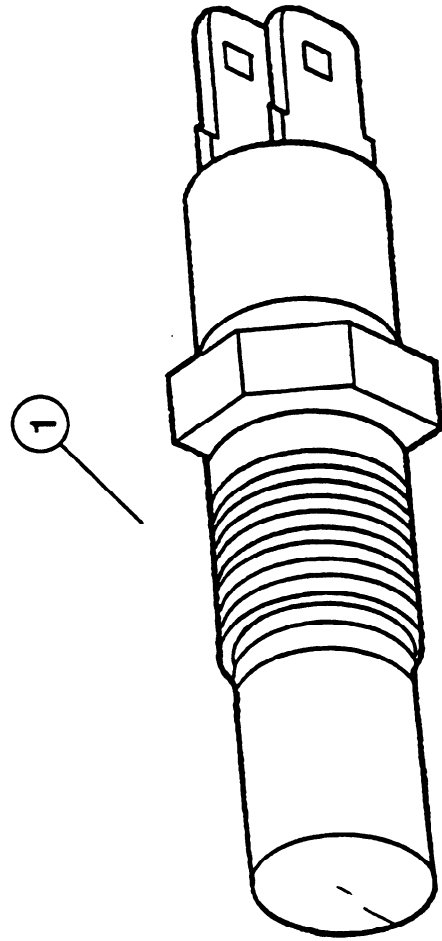

1. 101233 Water Regulator Assembly, (Wilkins)

2. 100218 Regulator, Water Pressure - 3/4" x 3/4" (PCL)

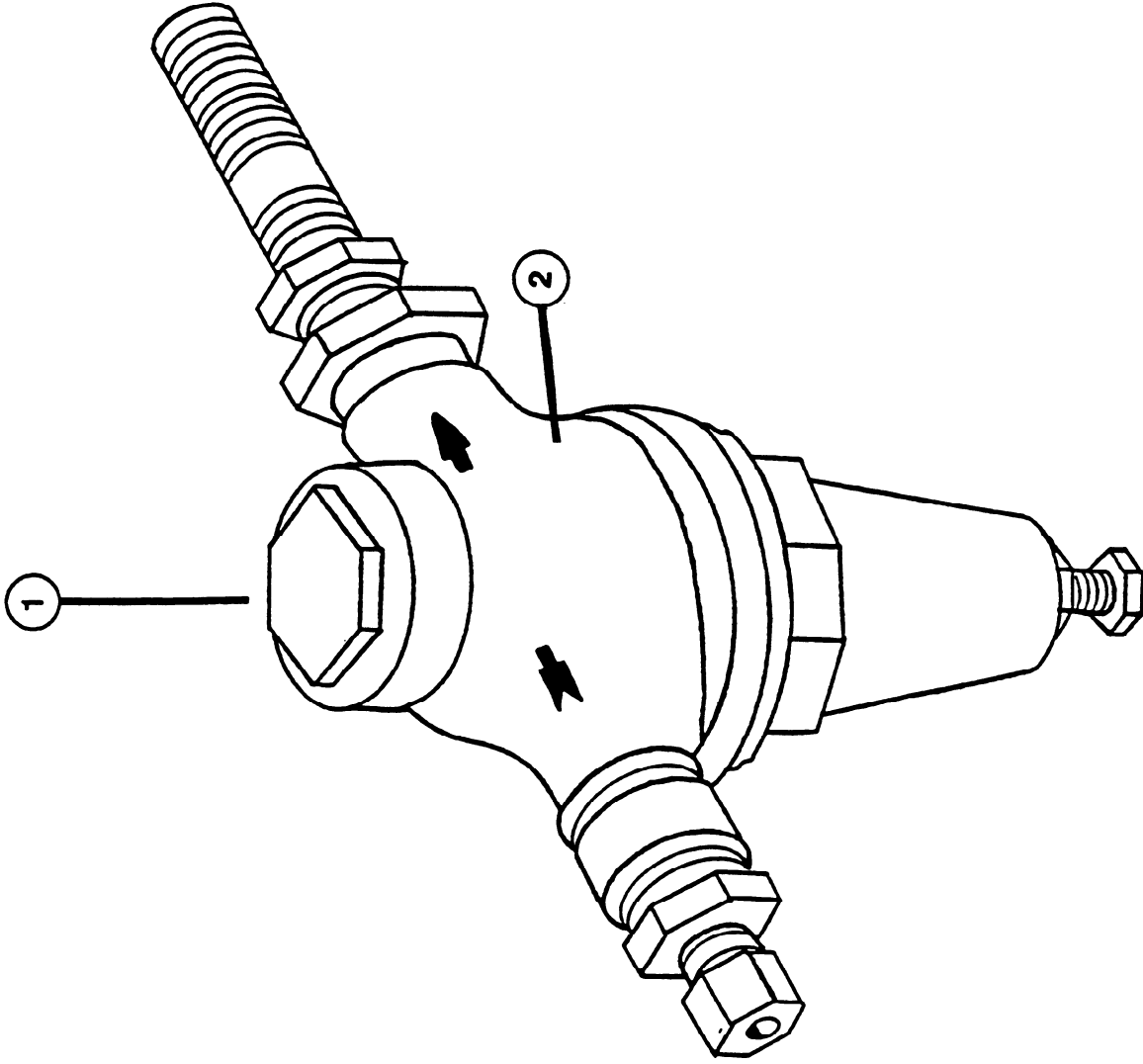

## Water Valve Assembly

- |    |        |  |
|----|--------|--|
| 1. | 07169  | Gauge 0-100 PSI, 2-1/2", 1/4" Bottom Mount, Brass Movement |
| 2. | 03606  | Coupling, Full, Brass, 1/2"                                |
| 3. | 100976 | Manifold, Water Valve Support PCL/PCS                      |
| 4. | 22241  | Valve, Solenoid 2-Way NC 1/4 NPT, Orifice 5/32 1200/60     |
| 5. | 22236  | Valve, Solenoid, 3-Way, 120 V/60 HZ                        |
| 6. | 14304  | Nipple, Yellow Brass, 1/4" x Close                         |
| 7. | 101061 | Manifold, Water Assembly, PCL/PCS                          |

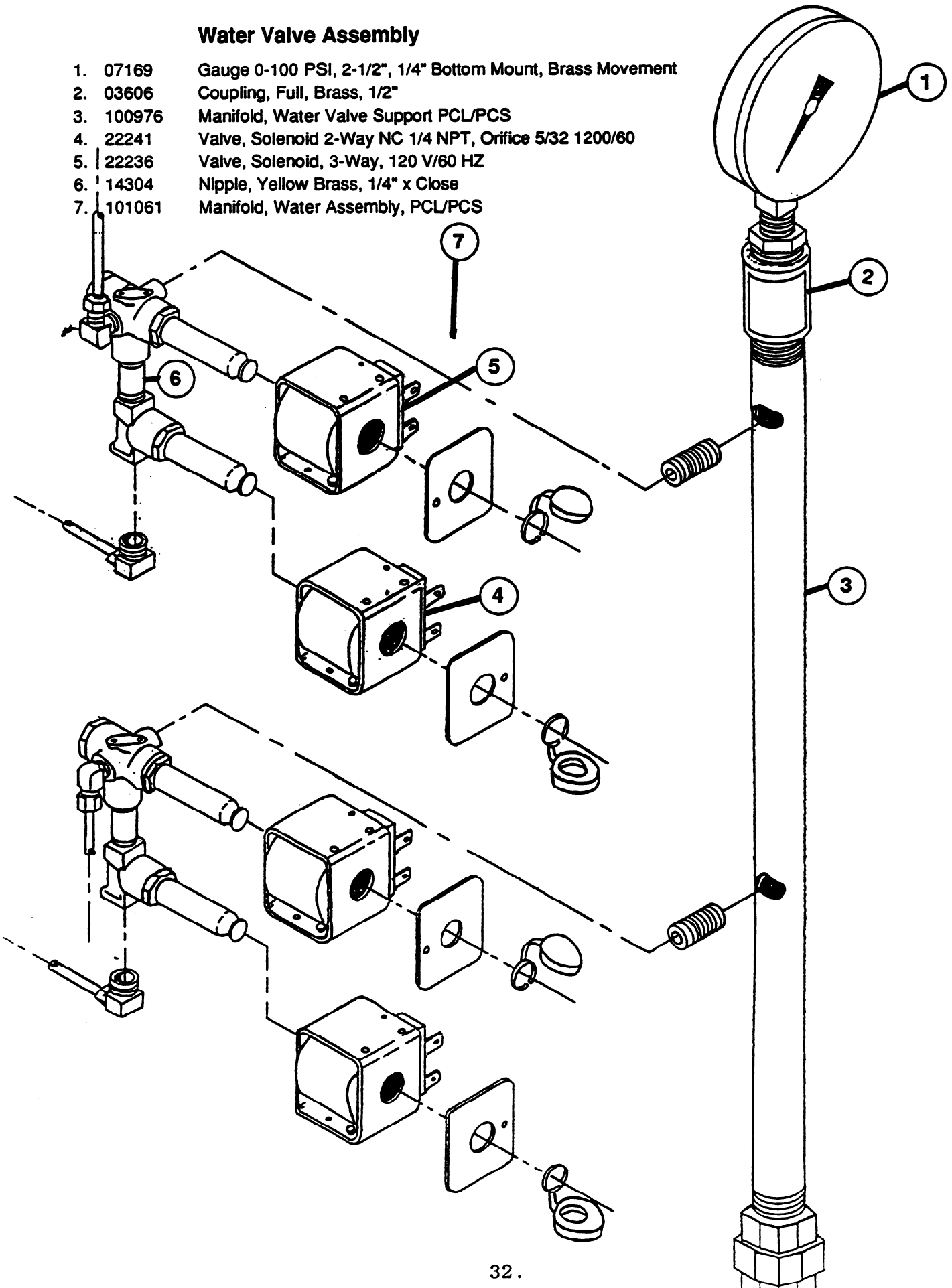

Pinch Valve number 104464

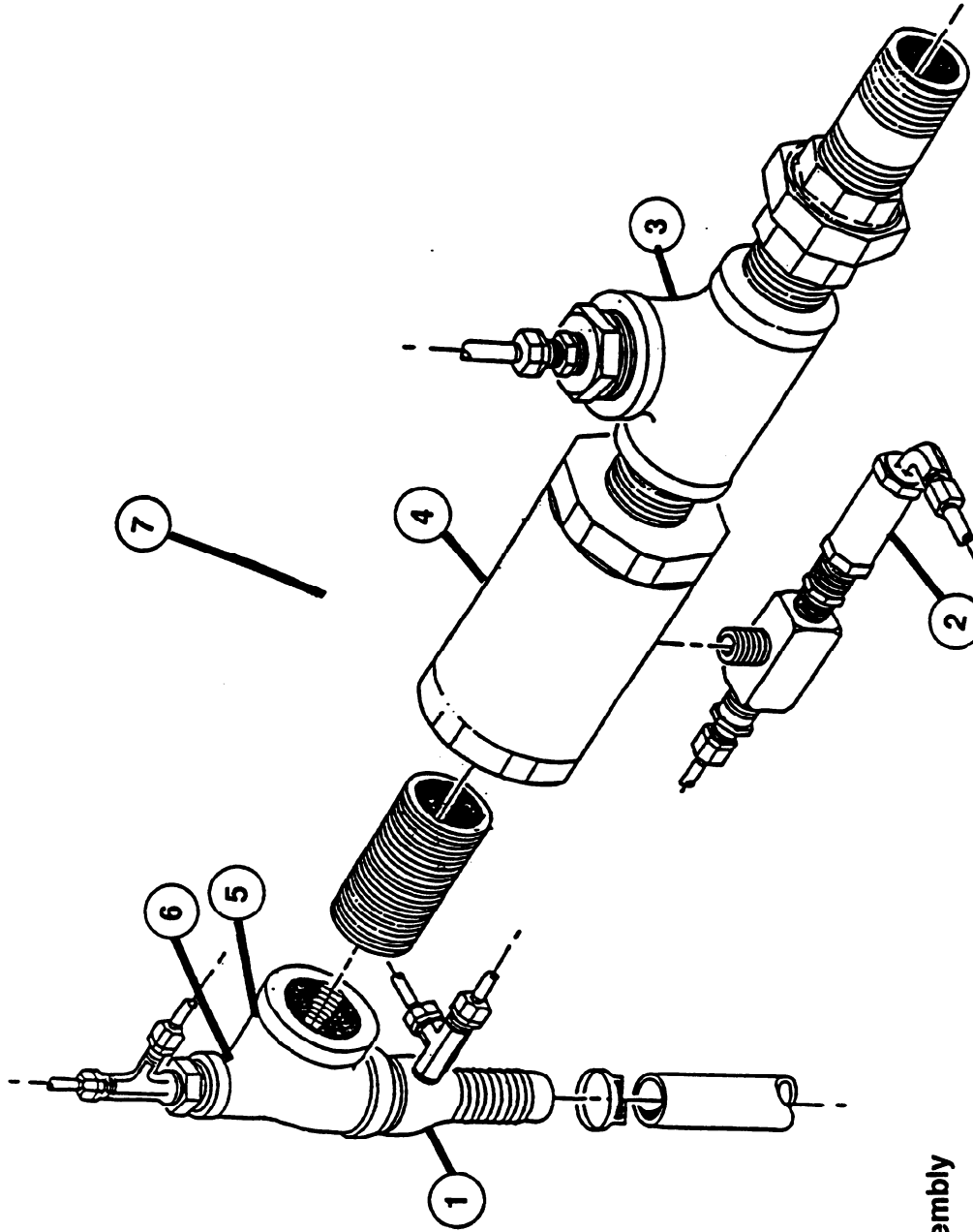

### Plumbing Assembly

1. 565191 Fitting - Hose Drain Manifold
2. 15462 Orifice, Flow Regulator 1/8" GPM
3. 20211 Tee-Black 1"
4. 22238 Valve, Pinch 1" NPT
5. 100223 Tee 1" x 1/2" x 1" Black
6. 14553 Nozzle, Spray Drain Manifold GP1 - 1/8 GG Full Jet, Brass
7. 100105 Plumbing Assembly, Upper Section (PCL)

LET.	REVISIONS	DATE	BY
A	PRODUCTION RELEASE PER EOM C-5318.	03-23-99	JRB
-	REF EOM 99-033	-	-

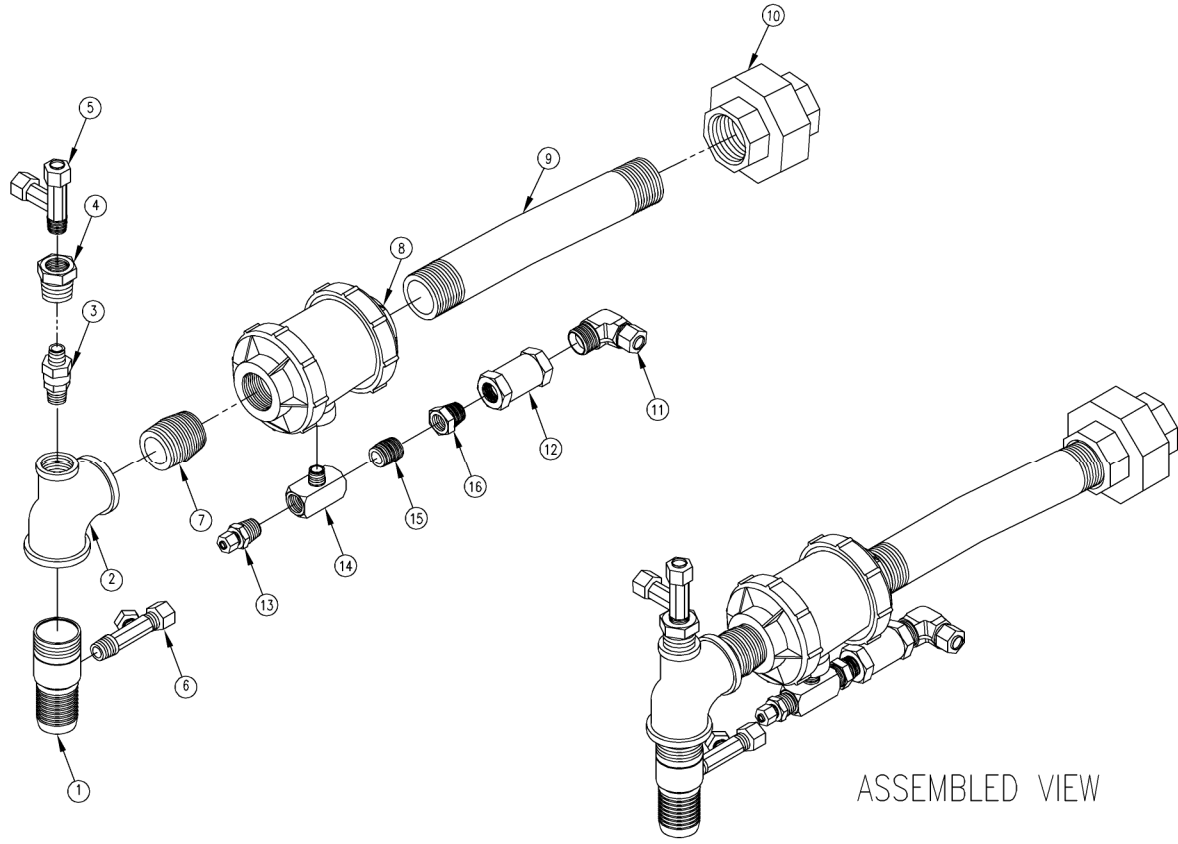

ASSEMBLED VIEW

ITEM	QTY	PART NO.	DESCRIPTION
16	1	02594	BUSHING, HEX, 3/8 X 1/4, BRASS
15	1	14334	NIPPLE, CLOSE, BRASS
14	1	20245	TEE, MALE BRANCH, 1/4 BRASS
13	1	00216	TEE, COMP, 1/4" x 1/4" NPT
12	1	15462	ORIFICE, FLOW REGULATOR, GPM
11	1	06194	TEE, COMP, 1/4" x 3/8" NPT, 90°
10	1	23326	NIPPLE, BLACK, 1 STANDARD
9	1	104548	NIPPLE, 8' OFFSET
8	1	104464	VALVE, PINCH INPT
7	1	14389	NIPPLE, 1 CLOSE, BLACK
6	1	101394	FITTING, COMP, TEE, 1/2NPT x 1/4 x 1/4
5	1	06198	TEE, COMP, TEE, 1/4" x 1/4" NPT BRASS
4	1	02549	BUSHING, CONDENSER
3	1	14553	NOZZLE, SPRAY, BRASS W/WH, 1/8 GGG-1, FULL NET, BR
2	1	100223	TEE, 1 x 1/2 x 1 BLACK
1	1	565191	FITTING, HOSE, 1 H x 1 NPT, W= 1/8 IN HOLE

TOLERANCES		CLEVELAND RANGE INC.	
DIMENSIONS		1333 East 179th St. Cleveland, Ohio 44110-2574	
DRAWN BY	SCALE	DESIGNED BY	APPROVED BY
JRB	1=1	J. BLOCK	
TITLE		ASSY, MANIFOLD	
SCALE		PINCH VALVE, PCL	
DATE	DRAWING NO.	REV	
3-10-99	D-109284	A	

THIS DESIGN DESCRIBES A PROPRIETARY ITEM AND IS THE PROPERTY OF CLEVELAND RANGE. THE DRAWING IS NOT TO BE COPIED OR USED WITHOUT THE APPROVAL OF CLEVELAND RANGE.

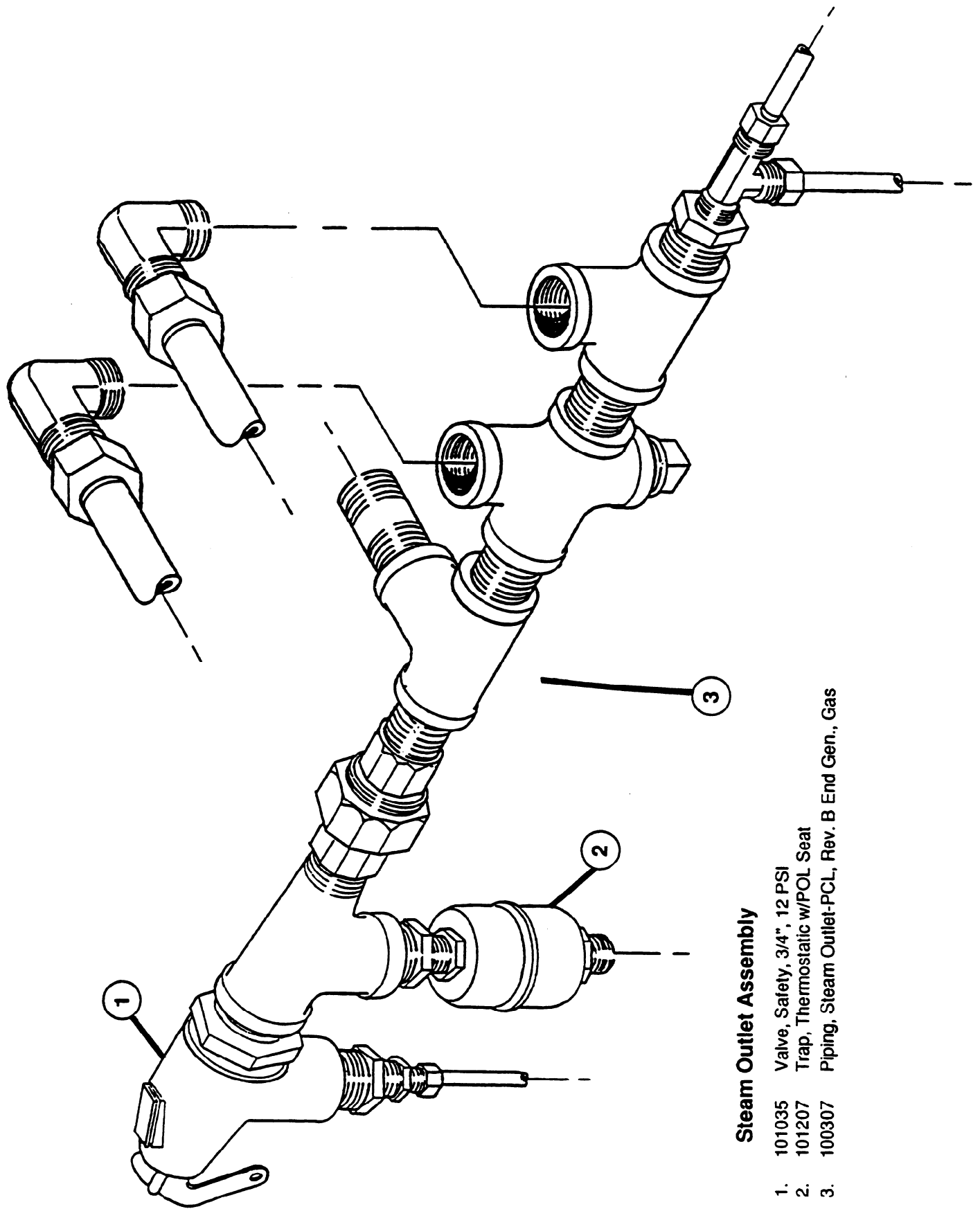

**Steam Outlet Assembly**

- 1. 101035 Valve, Safety, 3/4", 12 PSI
- 2. 101207 Trap, Thermostatic w/POL Seat
- 3. 100307 Piping, Steam Outlet-PCL, Rev. B End Gen., Gas

### Steam Valve Assembly

- 1. 22193 Value, Solenoid 3/4 x 3/4, 2NC 120V, 60HZ
- 2. 05295 Elbow, Union 1/2" x 1/2", Female to Female Brass
- 3. 101794 Steam Valve Assembly (PCL)

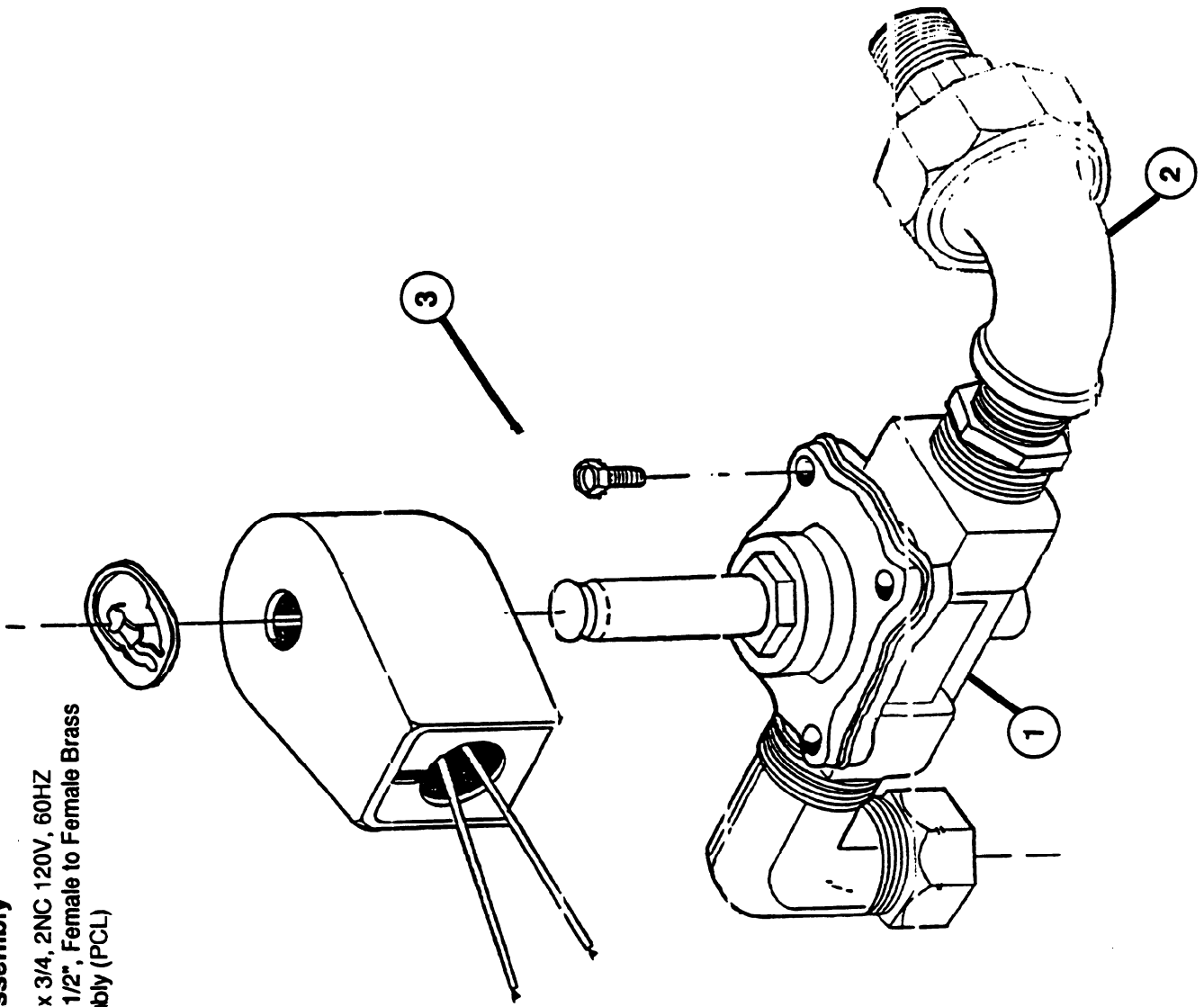

### Water Feed Assembly

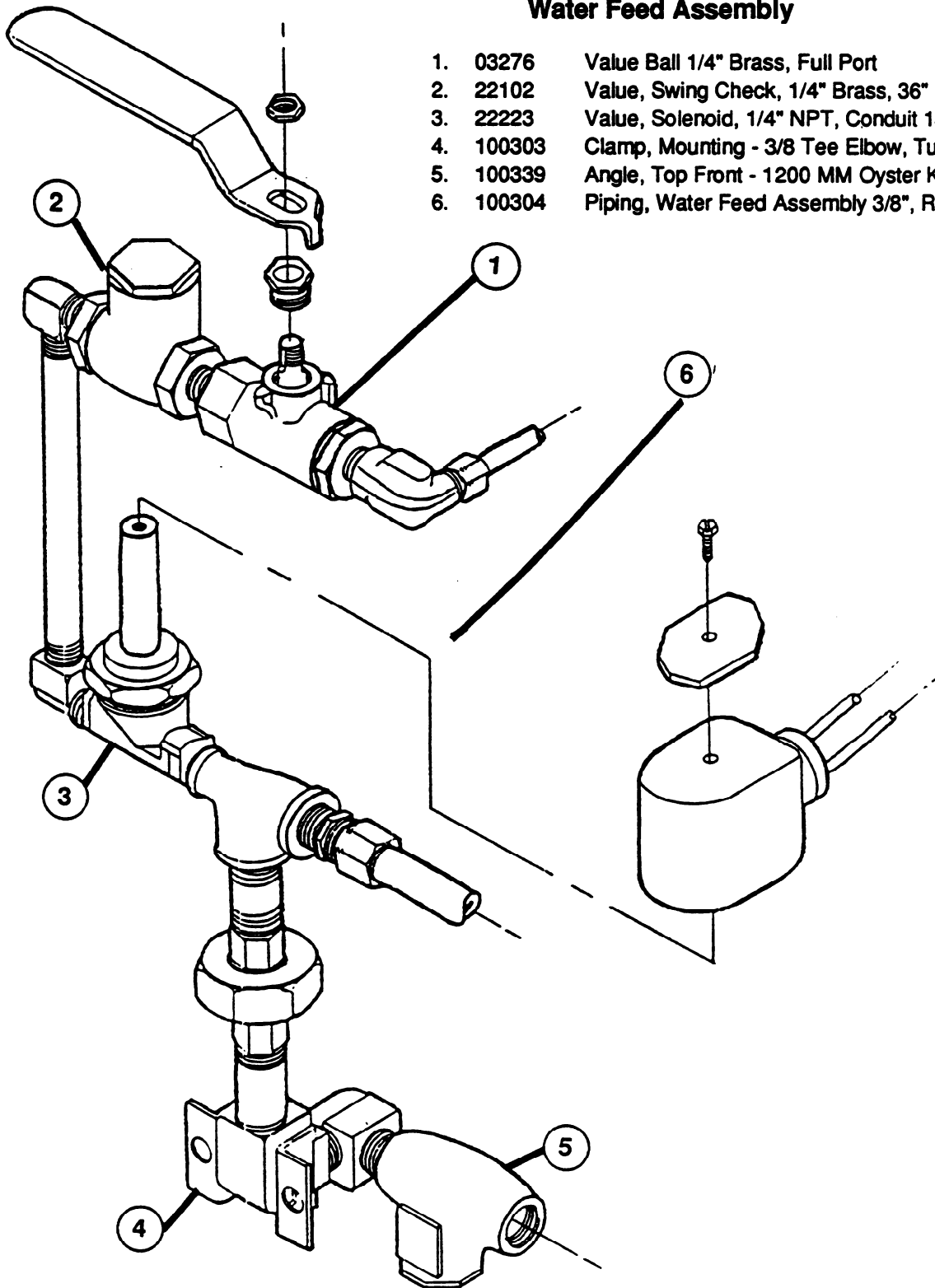

1. 03276 Value Ball 1/4" Brass, Full Port
2. 22102 Value, Swing Check, 1/4" Brass, 36" Leads
3. 22223 Value, Solenoid, 1/4" NPT, Conduit 130-120 V
4. 100303 Clamp, Mounting - 3/8 Tee Elbow, Tube Fitting
5. 100339 Angle, Top Front - 1200 MM Oyster Kettle Base
6. 100304 Piping, Water Feed Assembly 3/8", Rev. Bend Gen.

**Heater Assembly**

- 08165 Heater 12KW, 208-220V, 3" Square Flange, 3 Phase
- 08166 Heater, 12KW, 230-240V, 3" Square Flange, 3 Phase
- 08167 Heater, 12KW, 440-480V, 3" Square Flange, 3 Phase
- 07128 Heater Gasket

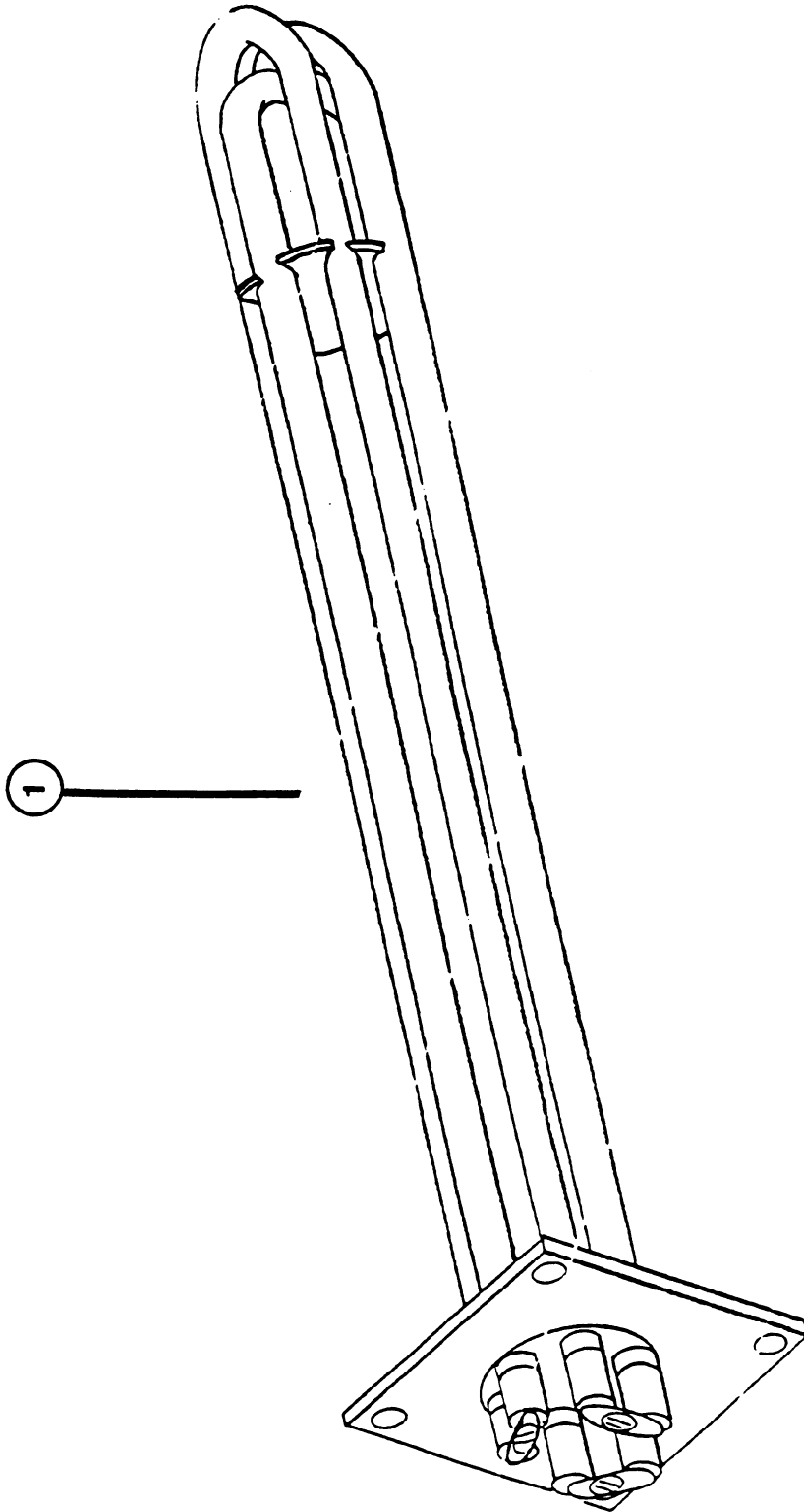

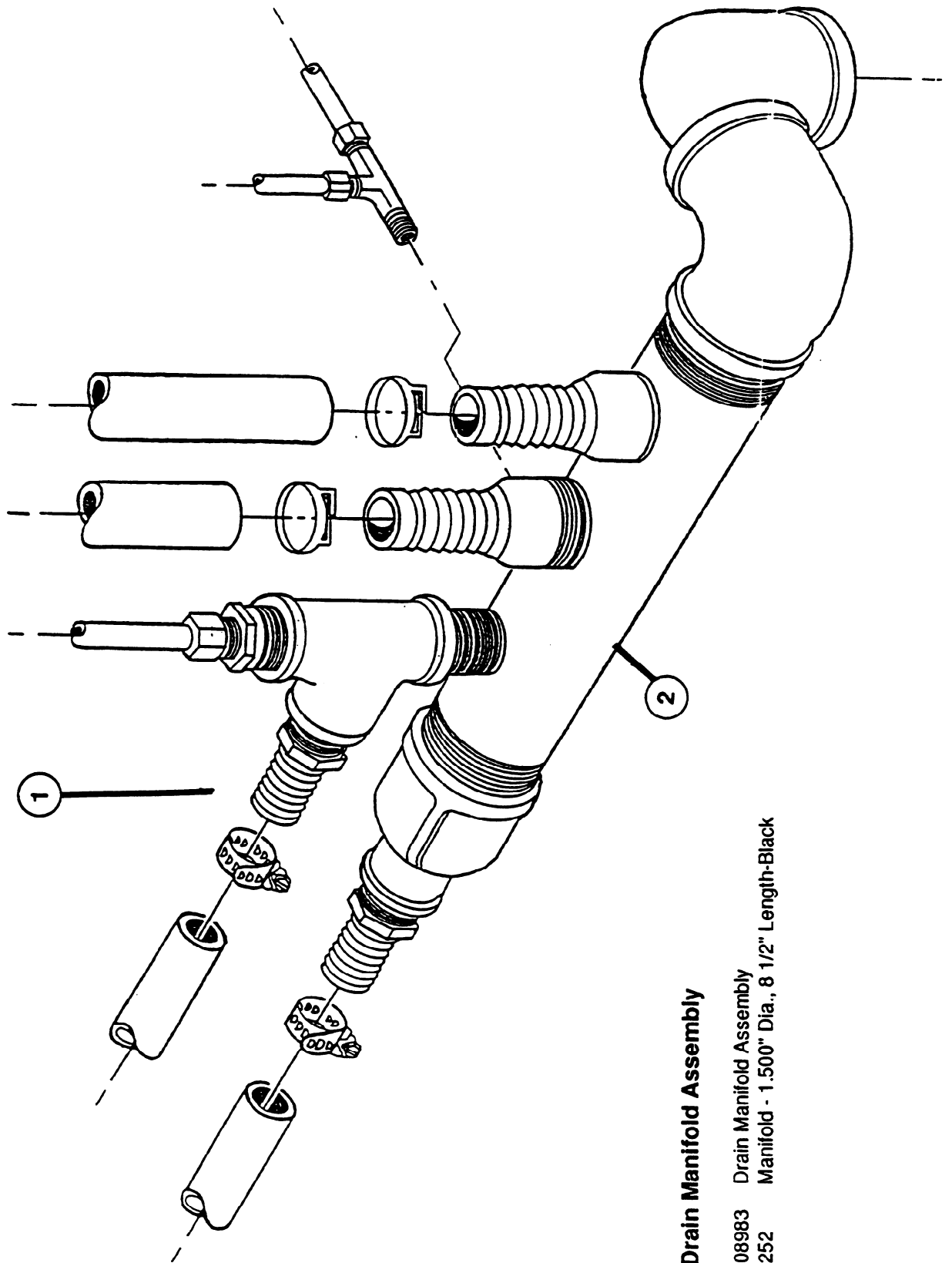

**Drain Manifold Assembly**

- 1. 1008983 Drain Manifold Assembly
- 2. 13252 Manifold - 1.500" Dia., 8 1/2" Length-Black

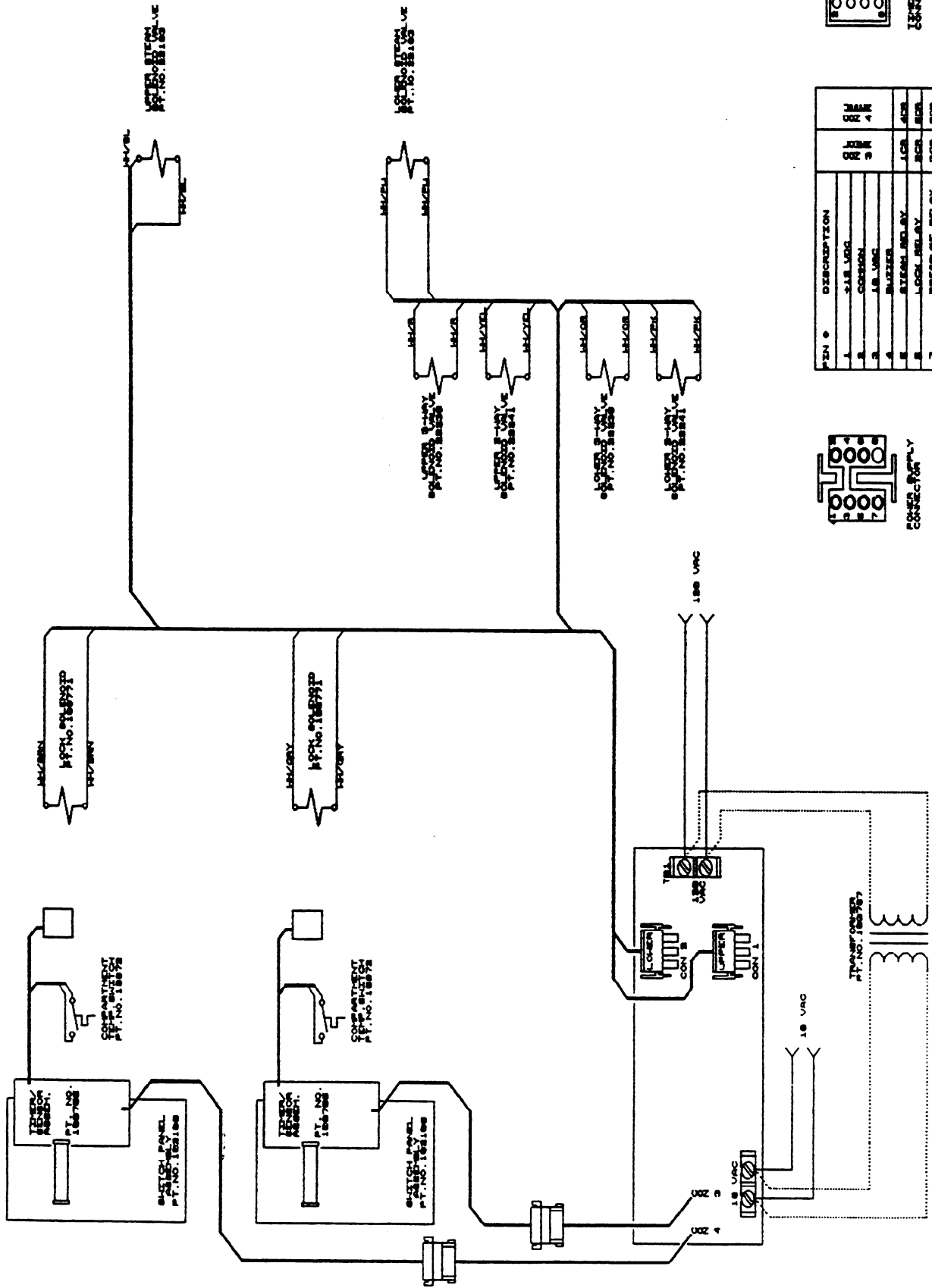

PEN #	DESCRIPTION	OFF	ON
1	188 VAC	OFF	ON
2	COMMON	OFF	ON
3	18 VAC	OFF	ON
4	BUZZER	OFF	ON
5	RELAY	OFF	ON
6	LOCK RELAY	OFF	ON
7	TRANSFER RELAY	OFF	ON
8	N.C.	OFF	ON

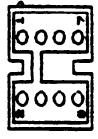
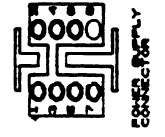

CONNECTOR

