

Cleveland

Service Manual

Model No. 6/9CEM18/27/36/48
6/9CGM100/200/250/300
6/9CDM
6/9CSM

Cleveland STATEMENT OF POLICIES

LIMITED WARRANTY

CLEVELAND RANGE products are warranted to the original purchaser to be free from defects in materials and workmanship under normal use and service for the standard warranty period of one year from date of installation or 18 months from date of shipment, whichever ever comes first.

CLEVELAND RANGE agrees to repair or replace, at its option, f.o.b. factory, any part which proves to be defective due to defects in material or workmanship during the warranty period, providing the equipment has been unaltered, and has been PROPERLY INSTALLED, MAINTAINED, AND OPERATED IN ACCORDANCE WITH THE CLEVELAND RANGE OWNER'S MANUAL.

CLEVELAND RANGE agrees to pay any FACTORY AUTHORIZED EQUIPMENT SERVICE AGENCY (within the continental United States, and Hawaii) for reasonable labor required to repair or replace, at our option, f.o.b. factory, any part which proves to be defective due to defects in material or workmanship, during the labor warranty period. This warranty includes travel time not to exceed two hours and mileage not to exceed 50 miles (100 miles round-trip), BUT DOES NOT INCLUDE POST START-UP, TIGHTENING LOOSE FITTINGS, MINOR ADJUSTMENTS, MAINTENANCE, CLEANING OR DESCALING.

The standard labor warranty allows factory payment of reasonable labor required to repair or replace such defective parts. Cleveland Range will not reimburse the expense of labor required for the repair or replacement of parts after the standard warranty period, unless an Extended Labor Warranty Contract has been purchased to cover the equipment for the balance of the warranty period from the date of equipment installation, start-up, or demonstration.

PROPER INSTALLATION IS THE RESPONSIBILITY OF THE DEALER, THE OWNER-USER, OR INSTALLING CONTRACTOR, AND IS NOT COVERED BY THIS WARRANTY. Many local codes exist, and it is the responsibility of the owner and installer to comply with these codes. Cleveland Range equipment is built to comply with applicable standards for manufacturers, including UL, ANSI, NSF, ASME/Ntl. Bd., CSA, and others.

BOILER (Steam Generator) MAINTENANCE IS THE RESPONSIBILITY OF THE OWNER-USER AND IS NOT COVERED BY THIS WARRANTY. The use of good quality feed water is the responsibility of the Owner-User (see Water Quality Recommendations below). THE USE OF POOR QUALITY FEED WATER WILL VOID EQUIPMENT WARRANTIES. Boiler maintenance supplies, including boiler hand hole gaskets, are not warranted beyond the first 90 days after the date the equipment is placed into service. Preventive maintenance records must be available showing descaling per applicable Cleveland Operator Manual for Boiler Proration Program considerations.

WATER QUALITY RECOMMENDATIONS

TOTAL DISSOLVED SOLIDS	less than	60 parts per million
TOTAL ALKALINITY	less than	20 parts per million
SILICA	less than	13 parts per million
CHLORIDE	less than	30 parts per million
pH FACTOR	greater than	7.5

The foregoing shall constitute the sole and exclusive remedy of original purchaser and the full liability of Cleveland Range for any breach of warranty. THE FOREGOING IS EXCLUSIVE AND IN LIEU OF ALL OTHER WARRANTIES, WHETHER WRITTEN, ORAL, OR IMPLIED, INCLUDING ANY WARRANTY OF PERFORMANCE, MERCHANTABILITY, OR FITNESS FOR PURPOSE, AND SUPERSEDES AND EXCLUDES ANY ORAL WARRANTIES OR REPRESENTATIONS, OR WRITTEN WARRANTIES OR REPRESENTATIONS, NOT EXPRESSLY DESIGNATED IN WRITING AS A "WARRANTY" OR "GUARANTEE" OF CLEVELAND RANGE MADE OR IMPLIED IN ANY MANUAL, LITERATURE, ADVERTISING BROCHURE OR OTHER MATERIALS.

CLEVELAND RANGE'S liability on any claim of any kind, including negligence, with respect to the goods or services covered hereunder, shall in no case exceed the price of the goods or services, or part thereof, which gives rise to the claim. IN NO EVENT SHALL CLEVELAND RANGE BE LIABLE FOR SPECIAL, INCIDENTAL, OR CONSEQUENTIAL DAMAGES, OR ANY DAMAGES IN THE NATURE OF PENALTIES.

LIMITED EXTENDED WARRANTY COVERAGE

The purchase of a Limited Extended Warranty Contract extends the standard warranty coverage to the purchased period of time (one to two years) from the date of installation, start-up, or demonstration, whichever is sooner.

*An additional two years Parts and Labor Warranty can be purchased with each piece of Cleveland equipment for an additional 2% of the List Price per year. The 2% of list price charge will be the net invoice amount for each year of extended warranty purchased.

- Extended warranty must be purchased at the same time the equipment is purchased.
- Extended Warranty has the same exclusions as stated in our standard warranty.

Second year limited extended warranty coverage on Cleveland Steamers when purchased with a water filter applies to water related components only.

INSTALLATION INSTRUCTIONS

for

STEAMERS, STEAMER/KETTLES, MODULAR BOILER BASES, and KETTLES ON BOILER BASES

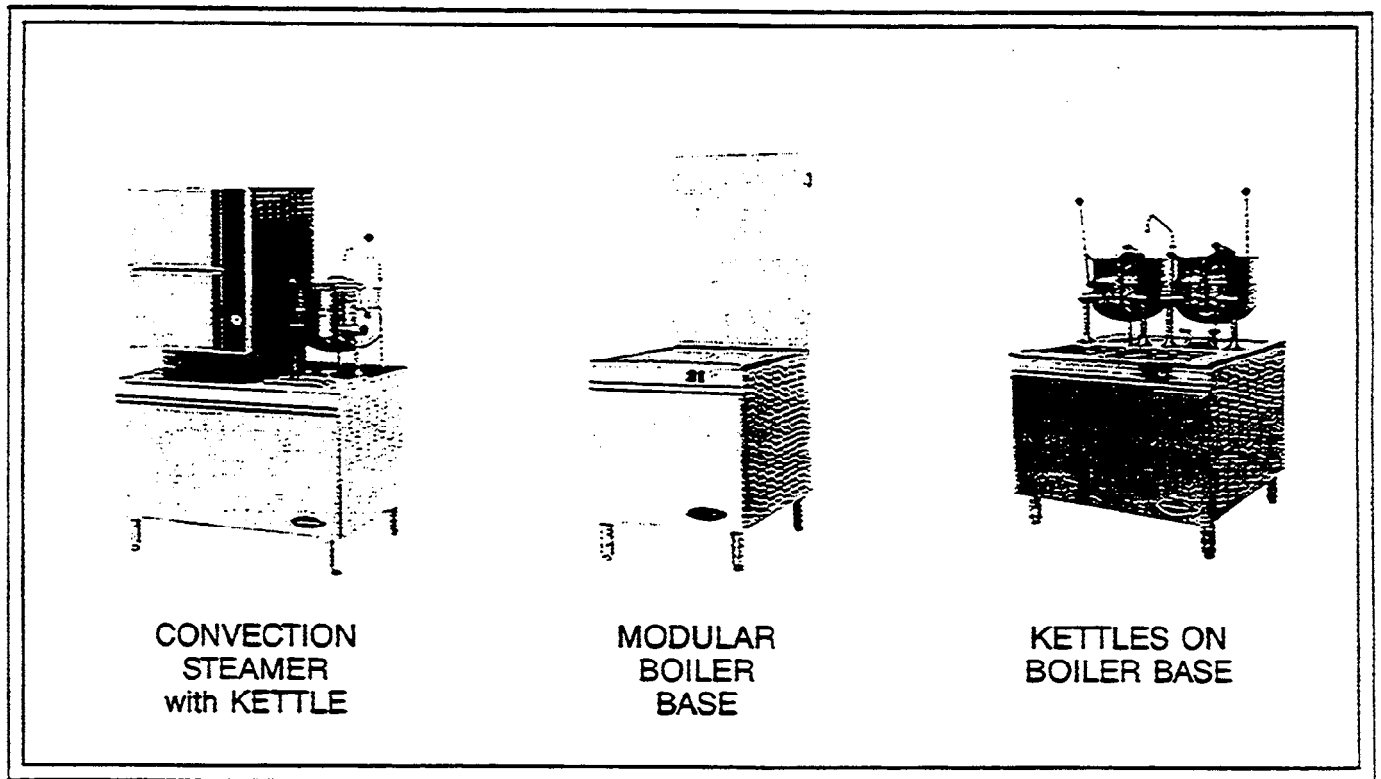

CONVECTION
STEAMER
with KETTLE

MODULAR
BOILER
BASE

KETTLES ON
BOILER BASE

Cleveland Range, Inc.

UNITED STATES

1333 East 179th St.
Cleveland, Ohio 44110
Phone: (216) 481-4900 • Telex: 98-0546 • FAX: (216) 481-3782

CANADA

Garland Commercial Ranges • 1177 Kamato Rd.
Mississauga, Ontario CN L4W 1X4
Phone: (416) 624-0260 • FAX: (416) 624-0623

INSTALLATION INSTRUCTIONS FOR STEAMERS, STEAMER/KETTLES, MODULAR BOILER BASES, and KETTLES ON BOILER BASES

FOR YOUR SAFETY

Do not store or use gasoline or other flammable vapors and liquids in the vicinity of this or any other appliance.

WARNING

Installation of this equipment must be accomplished by qualified installation personnel, working to all applicable local and national codes. Improper installation of this product could cause injury or damage.

Cleveland Range equipment is designed and built to comply with applicable standards for manufacturers. Included among those certification agencies which have approved the safety of the equipment design and construction are: UL, A.G.A., NSF, ASME, CSA, CGA, and others.

Cleveland Range equipment is designed and certified for safe operation only when permanently installed in accordance with local and/or national codes. Many local codes exist, and it is the responsibility of the owner and installer to comply with these codes.

In no event shall Cleveland Range assume any liability for consequential damage or injury resulting from installations which are not in strict compliance with our installation instructions. Specifically, Cleveland Range will not assume any liability for damage or injury resulting from improper installation of equipment, including, but not limited to, temporary or mobile installations.

INSTALLATION INSTRUCTIONS FOR ALL MODELS

1. These instructions must be retained by the owner/user for future reference. Gas-fired boilers are only to be installed in noncombustible areas that have provisions for adequate air supply. The term "boiler" will be used synonymously with "steam generator."

WARNING

The flooring that will be directly under the boiler, must also be made of a noncombustible material.

2. Position: For proper operation and drainage, the equipment must be level. It should be placed next to an open floor drain. **DO NOT POSITION THE UNIT DIRECTLY ABOVE THE FLOOR DRAIN.** Observe all clearance requirements to provide air supply for proper operation, as well as sufficient clearance for servicing. The surrounding area must be free and clear of combustibles. Dimensions and clearance specifications are shown on the specification sheet.
3. Install in accordance with local codes and/or the National Electric Code ANSI/NFPA No. 70-1987. Installation in Canada must be in accordance with the Canadian Electrical Code CSA Standard C22.1. Equipment that is connected to electricity must be grounded by the installer. A wiring diagram is provided inside the base cabinet.
4. The drain line outlet discharges exhaust steam and hot condensate. Connect 1½" IPS piping (or larger) to extend the drain line to a nearby open floor drain. Up to two elbows and six feet of 1½" IPS (or larger) extension pipe should be connected to the drain termination. Drain piping extended six to twelve feet, or using three elbows, should be increased to 2" IPS. No more than two pieces of Cleveland Range equipment should be connected to one common drain line. The maximum length of extension from the drain termination should not exceed six feet and use no more than two elbows. The extension piping must have a gravity flow and vent freely to the air. This drain outlet must be free-vented to avoid the creation of back pressure in the steamer cooking compartments. To ensure a vented drain line, **DO NOT, UNDER ANY CIRCUMSTANCES, CONNECT THE DRAIN OUTLET DIRECTLY TO THE FLOOR DRAIN OR SEWER LINE.** Do not run the drain line discharge into PVC drain piping or any other drain piping material not capable of sustaining 180°F operation.

FAILURE TO OBSERVE THESE REQUIREMENTS CAN RESULT IN DAMAGE TO EQUIPMENT AND/OR THE POSSIBILITY OF INJURY.

(Continued on next page)

- Direct-steam connected pressure steamers do not require a cold water connection, and therefore steps #5 and #6 do not apply. Refer directly to step #7. A kettle fill faucet, if so equipped, requires a hot and/or cold water connection. The data contained in step #5 for cold water also applies to hot water.

5. Connect COLD water supply plumbing to the line strainer. (Never connect hot water to the boiler's water fill line strainer). Constant flow pressure must be maintained between 35 and 60 psi, and not experience a pressure drop below 35 psi when other appliances are used. If the water pressure exceeds 60 psi, a pressure reducing valve must be installed in the water supply plumbing to reduce the water pressure to less than 60 psi. Locations and pressure data are shown on the specification sheet. 1/4" IPS plumbing is sufficient for water supply lines up to 20 feet in length, but water supply lines longer than 20 feet should be at least 3/8" IPS. Flush water supply lines thoroughly before connecting them to the unit. Use water which is low in total dissolved solids content and low in gas content to prevent internal scaling, pitting and corrosion of the steam generator, and carry-over of minerals into the steam. Water which is fit to drink can still contain highly detrimental impurities.

NOTE: If equipped with a kettle and kettle water fill swing spout, 3/8" (10mm) hot and/or cold water connection(s) will be required at the swing spout's valve.

6. Turn on the cold water supply to the unit. Ensure that the manual water valve, inside the base cabinet, is open.
7. Connect the primary fuel supply in accordance with the following instructions. Location and other data are shown on the specification sheet.

For Gas-Fired Steam Generators:

Post, in a prominent location, instructions to be followed in the event the user smells gas. This information shall be obtained by consulting the local gas supplier. Install a sediment trap (drip leg) in the gas supply line, then connect gas supply piping to the boiler's gas valve piping. **GAS-FIRED EQUIPMENT IS DESIGNED FOR INSTALLATION ONLY IN NON-COMBUSTIBLE LOCATIONS. THIS INCLUDES THE FLOORING THAT WILL BE DIRECTLY UNDER THE EQUIPMENT.** Location, plumbing size, and pressure data are shown on the specification sheet. Boilers rated at less than 225,000 BTU require 3/4" IPS gas supply piping, and boilers rated at 225,000 BTU or more require 1" IPS gas supply piping. Natural gas supply pressure must be between 4" - 14" water column, and L.P. gas supply pressure must be between 12" - 14" water column. **NEVER EXCEED 14" WATER COLUMN (1/2 psi) GAS PRESSURE.** If the gas supply pressure exceeds 14" water column, a pressure regulating valve must be installed in the gas supply plumbing to reduce the gas pressure to less than 14" water column. Installation must be in accordance with local codes, or in the absence of local codes, with the National Fuel Gas Code, ANSI Z223.1-1984. Installation in Canada must be in accordance with Installation Codes for Gas Burning Appliances and Equipment B149.1 and B149.2. Use a gas pipe joint compound which is resistant to LP gas. Turn the gas valve's control knob to "on" (the word "on" on the knob will be opposite the index on the valve's body). Test all pipe joints for leaks with soap and water solution. Never obstruct the flow of combustion and ventilation air. Observe all clearance requirements to provide adequate air openings into the combustion chamber. The appliance and its individual shut-off valve must be disconnected from the gas supply piping system during any pressure testing of that system at test pressures in excess of 1/2 psi (14" water column or 3.45 kPa). The appliance must be isolated from the gas supply piping system at test pressures equal to or less than 1/2 psi (14" water column or 3.45 kPa). A permanent 115 volt electrical connection is required at the junction box. The junction box location is shown on the specification sheet. The unit must be electrically grounded by the installer.

For Electric-Powered Steam Generators:

Connect electric power: location and data are shown on the specification sheet. Provide connection as required by your unit; either directly to the single contactor, or to the terminal block (when equipped with multiple contactors). Electric supply must match power requirements specified on the data plate inside the base cabinet. The copper wiring must be adequate to carry the required current at the rated voltage. A separate fused disconnect switch must be supplied and installed. The unit must be electrically grounded by the installer.

For Steam Coil Steam Generators:

Connect steam supply piping to the input side of the steam coil. Location and pressure data are shown on the specification sheet. Incoming steam pressure must be regulated between 35 and 45 psi. A 3/4" strainer, equipped with a 20 mesh stainless steel screen, must be supplied and installed at the incoming steam connection point. Flush the steam line thoroughly before connecting it to the boiler. To ensure an adequate volume of steam, the branch steam supply line must be 3/4" IPS minimum. Connect the inverted bucket trap to the outlet end of the steam coil. Fill the trap with water before installing it. A permanent 115 volt electrical connection is required at the junction box. The junction box location is shown on the specification sheet. The unit must be electrically grounded by the installer.

For Direct-Steam-Connected Steamers/Kettles:

Connect steam supply piping to the input side of the line strainer. Location and pressure data are shown on the specification sheet. Flush the steam line thoroughly before connecting it to the steamer. To ensure an adequate volume of steam, the branch steam supply line must be 3/4" IPS minimum. (Direct-steam-connected kettles require 1/2" IPS pipe if the kettle's total capacity is 20 gallons or less, and 3/4" IPS pipe if the total capacity exceeds 20 gallons.) A permanent 115 volt electrical connection is required at the junction box. The junction box location is shown on the specification sheet. The unit must be electrically grounded by the installer. (Note: pressure steamers equipped with strictly manual steam and drain valves do not require an electrical connection.)

(Continued on reverse side)

(Continued)

8. Press the top of the power on-off rocker switch. The red indicator light in the switch will come on and the boiler will begin to fill with water.

- Direct-steam-connected steamers are not equipped with self-generating boilers or "steam" switches. Therefore, these models do not require the 5-minute boiler water fill time, nor is it necessary to push a "steam" switch to produce steam, as indicated in step #9. As soon as the pressure gauge on the control panel registers 10 psi (5 psi for pressure steamers), preheating may begin. If you are operating a direct-steam-connected steamer, steps #9 and #10 do not apply. Refer directly to step #11.

9. After about five minutes, the amber light in the "steam" switch will glow, indicating the water has reached a safe operating level in the boiler. The "steam" switch can now be pressed (momentarily) in order to produce steam in the boiler. This will activate the energy source (electric heaters, gas burners, or steam solenoid valve), and the amber light will go out. The energy source cannot be activated until the boiler contains sufficient water, indicated by the amber light. The "steam" switch must be pushed to re-start the steamer after it is shut off for any reason (including a momentary power interruption). Do not attempt to start or operate this appliance during a power failure. Whenever the amber light is illuminated, the heater, steam supply, or burners are off, and no steam is being generated. (Note: for units containing gas-fired boilers only: if the burners fail to ignite in four seconds, a safety circuit will de-energize the system. In this event, momentarily press the power switch to the "off" position, then back to the "on" position. The "steam" switch amber light should be on. Wait 5 minutes, then press the "steam" switch to start the burner ignition cycle once again.)

10. Check to ensure that the water in the boiler's sight gauge glass automatically stays about 1/3 full when the boiler is started up and operated.

11. Check to ensure that the steam pressure gauge registers 10 psi (5 psi for pressure steamers).

The steam pressure is factory-adjusted to provide the proper pressure. In some cases, however, the factory setting may shift due to shaking in transit, and resetting will be required after installation. Proper adjustments and maintenance procedures are detailed on a separate data sheet entitled "Steam Pressure Adjustments." Adjustments should be made only by qualified service personnel. The factory pressure settings shown in the accompanying chart should never be exceeded.

12. When the installation is complete and free of leaks, refer to the Operating Procedures page, in order to check for proper operation of the unit.

GAUGE PRESSURE READING WITH NO STEAM FLOW (STATIC PRESSURE)								
Equipment	Self-Contained Steam Generator Gas or Electric			Self-Contained Steam Coil Generator			Direct-Connect (To "House" Steam Supply)	
	Steamer's Pressure Reducing Valve	Operating Pressure Switch	High Limit Safety Pressure Switch	Operating Pressure Switch	High Limit Safety Pressure Switch	Steam Supply Pressure Range	Steamer's Pressure Reducing Valve	Steam Supply Pressure Range
Steam Generator Only 5 psi	N/A	5 psi	10 psi	5 psi	10 psi	30-45 psi	N/A	N/A
Pressure Steamer	N/A	5 psi	10 psi	5 psi	10 psi	30-45 psi	5 psi	12-45 psi
Pressure Steamer With Any Kettle(s)	5 psi	10 psi	15 psi	5 psi	10 psi	30-45 psi	5 psi	12-45 psi
Steam Generator Only 10 psi	N/A	10 psi	15 psi	10 psi	15 psi	30-45 psi	N/A	N/A
Kettle Only — All	N/A	10 psi	15 psi	N/A	N/A	N/A	N/A	5-45 psi
Convection Steamer With or Without Kettles	N/A	10 psi	15 psi	10 psi	15 psi	35-45 psi	10 psi	15-45 psi

*Kettles are to be connected to the "house" steam supply.

CLEVELAND CONVECTION STEAMER (MODEL C) OPERATING INSTRUCTIONS

Operation of the Cleveland Convection Steamer is very easy. Each operator should read and understand the following procedures to effectively start, operate, and shutdown the steamer each day.



Start-up and Preheat

1. Check the cooking compartments to ensure that the steam tubes and drain screens are in place and secure. Check inside the steamer's base cabinet to ensure that the manual drain valve is closed and the manual water supply valve is open.
2. Press the top of the power on-off rocker switch located at the lower left of the control panel, under the steam pressure gauge. The red indicator light in the switch will come on and the boiler will begin to fill with water.
 - Direct-steam-connected steamers are not equipped with self-generating boilers or "steam" switches. Therefore, these models do not require the 5 minute boiler water fill time, nor is it necessary to push a "steam" switch to produce steam, as indicated in step #3 below. As soon as the pressure gauge on the control panel registers 10 psi, preheating may begin. If you are operating a direct-steam-connected steamer, "skip" step #3, and refer directly to step #4.
3. After about five minutes, the amber light in the "STEAM" switch will glow indicating the water has reached a safe operating level in the boiler. The "STEAM" switch can now be pressed (momentarily) in order to produce steam in the boiler. This will activate the energy source (electric heaters, gas burners, or steam solenoid valve), and the amber light will go out. The energy source cannot be activated until the boiler contains sufficient water, indicated by the amber light. The "STEAM" switch must be pressed to re-start the steamer after it is shut off for any reason (including a momentary power interruption). No attempt should be made to operate the equipment during a power failure. Whenever the amber light is illuminated, the heaters, steam supply, or burners are off, and no steam is being generated. (Note for steamers containing gas-fired boilers only: If the burners fail to ignite in four seconds, a safety circuit will de-energize the system. In this event, momentarily press the power switch to the "off" position, then back to the "on" position. The "STEAM" switch's amber light should be on. Wait 5 minutes, then press the "STEAM" switch to start the burner ignition cycle once again.) In about 20 minutes the steam pressure gauge on the control panel should register 10 psi.
4. You can now preheat the cooking compartment(s). Cooking compartments should always be preheated before cooking.

NOTE: With a steamer / kettle combination, if both must be used at the same time, always heat the kettle first. When kettle contents begin to simmer, and steam pressure returns, the steamer compartments may be preheated.
5. To preheat, close the compartment door by gently swinging it shut. Set the electronic digital timer for one minute, in accordance with the following timer setting instructions. It will be several minutes before the time display begins to count down. When the preheating is completed, the steam will automatically shut off and a four second alarm will sound.



Timer Setting:

Each Convection Steamer compartment is equipped with an independent electronic digital timer, which has a maximum setting of 99 minutes. Each timer is connected to a temperature sensing device in the cooking compartment. THIS SENSOR WILL ALLOW THE TIMER TO COUNT DOWN ONLY WHEN THE INTERNAL COMPARTMENT REACHES PROPER COOKING TEMPERATURE. This assures uniformity in the cooking times the operator will use, as the timer automatically compensates for food product defrosting and/or heat-up time.

The timer can be set when the "COOKING TIME" display shows "00" (double zeros) which are illuminated continuously (not flashing). The two small, square pads below the timer display are pressed to set the timer. Press  to set one to nine (and zero) minutes for units digits (single minutes). Press  to set ten to ninety minutes for ten's digit (multiples of ten minutes). Pressing continuously on either pad causes the digits to change at a rate of 2 digits per second. If you pass the correct digit, continue pressing the pad. The display will cycle from "9" back to "0," then continue upward again.

The timer is activated (and steam enters the cooking compartment) when the "START / cancel" pad is pressed. Red L.E.D. lights glow in the upper-left corner of the pad and the lower-right corner of the time display when the timer is activated. REMEMBER, THE TIMER WILL BEGIN TO COUNT DOWN ONLY AFTER THE COMPARTMENT REACHES PROPER COOKING TEMPERATURE. When the timer is counting down, the red L.E.D. light continuously flashes on and off at the lower-right corner of the display. Once the pre-set time has counted down to zero, an alarm will sound for four seconds, and the timer display will continuously flash "00" until the "start/CANCEL" pad is pressed.

Once the timer is activated, the time cannot be changed unless the "start/CANCEL" pad is pressed. Once pressed, the pad's L.E.D. will go out, any remaining time in the timer will be cancelled, and the display will show "00" — not flashing. A new time setting can now be entered into the timer display.

EXAMPLE: To cook for 14 minutes: Press the "start/CANCEL" pad to be sure the timer display shows "00" and is not flashing. Press the  pad, then release it when the "1" appears in the display. Press the  pad, and release it when the "4" appears in the display. Press the "START / cancel" pad to start the timer (note the illuminated red L.E.D.'s in the pad and the time display). When the display counts down to zero, a four second alarm will sound, and the display will flash "00" (the L.E.D.'s will go out). Press the "start/CANCEL" pad to reset the timer, shown by continuously illuminated "00" in the display (not flashing).

Automatic Cooking Operation:

To cook, place a pan of food in the compartment, set the desired cooking time, and press the "START / cancel" pad. The timer will delay, automatically compensating for defrosting and/or food product heat-up time. If you have set the timer at 10 minutes, it may in fact take 11 or 12 minutes for the set time to expire and the alarm to sound. This is normal: the additional time was used to heat the compartment and food product to cooking temperature. When the display counts down to zero, the four second alarm will sound, and the display will flash "00" (the L.E.D.'s will go out). Press the "start/CANCEL" pad to reset the timer, shown by continuously illuminated "00" in the display.

Manual Cooking Operation:

If a cooking cycle longer than 99 minutes is desired, do not use the timer. Just press the "MANUAL OPERATION" pad, located below the timer, to start the flow of steam. You must press the pad again to shut off the steam. A red L.E.D. light in the upper-left corner of the pad illuminates when the manual mode is activated, and steam is flowing into the cooking compartment. THE TIMER CAN BE USED DURING THIS TIME. IT WILL OPERATE AS STATED, EXCEPT IT WILL NOT TURN OFF THE STEAM AFTER THE ALARM SOUNDS.

The door may be opened for food inspection anytime during the cooking cycle, but KEEP HANDS OUT OF THE COOKING COMPARTMENT TO PREVENT BURNS. Optimum steam heat transfer, and therefore a higher quality food product, is achieved when shallow, perforated, uncovered pans are used.

Boiler Shutdown:

The red-lighted power switch must be shut off for 3 minutes a minimum of once every 8 hours to automatically drain highly mineralized water from the boiler, which reduces the formation of scale.

CONVECTION STEAMER MECHANICAL COMPONENTS

(Solid State Model "C" with Touch Control Timer Panel)

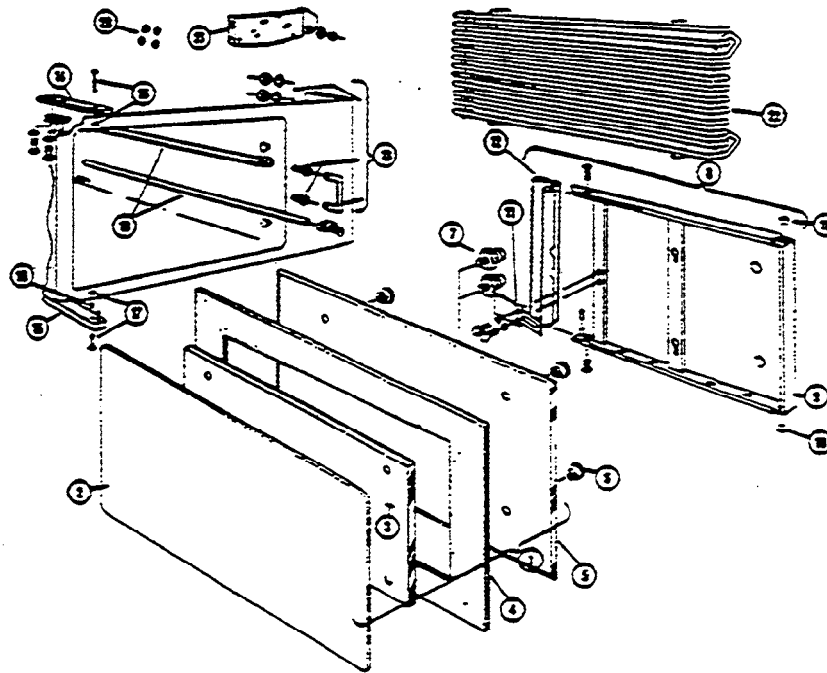

REFERENCE NUMBER	PART NUMBER	DESCRIPTION
1	44090	Inner Door Assembly
2	44098	Gasket Retainer Plate
3	66214	Inner Gasket Retainer Plate
4	07138	Gasket
5	04171	Inner Door
6	14667	Knurled Finger Nut, 1/4-20
7	66508	Inner Door Mounting Stud
8	44067	Outer Door Assembly
9	44088	Outer Door Weldment
10	02088	Bushing (2 required)
11	69629	Door Spring
12	44167	Door Latch Assembly
	58113	Door Latch (less plastic insert & screws)
	70636	Plastic Insert (not shown)
	19152	Pivot Screw (2 required)
13	40678	Door Catch Assembly
14	58178	Upper Hinge Bracket (lower if door is hinged right)
15	58179	Lower Hinge Bracket (upper if door is hinged right)
16	40883	Upper Hinge Pin and Retainer (lower if door is hinged right)
17	40884	Lower Hinge Pin and Retainer (upper if door is hinged right)
18	19552	Spacer
19	40783	Steam Tube
20	15203	O Ring (4 required)
21	69298	Drain Screen (After Dec. 1, 1983)
	69233	Drain Screen (Before Dec. 1, 1983)
22	41423	Slide Rack

0685

CLEVELAND RANGE, INC., 1333 EAST 179th ST., CLEVELAND, OHIO 44110

Manufacturer reserves right of design improvement or modification, as warranted.

LITHO IN U.S.A.

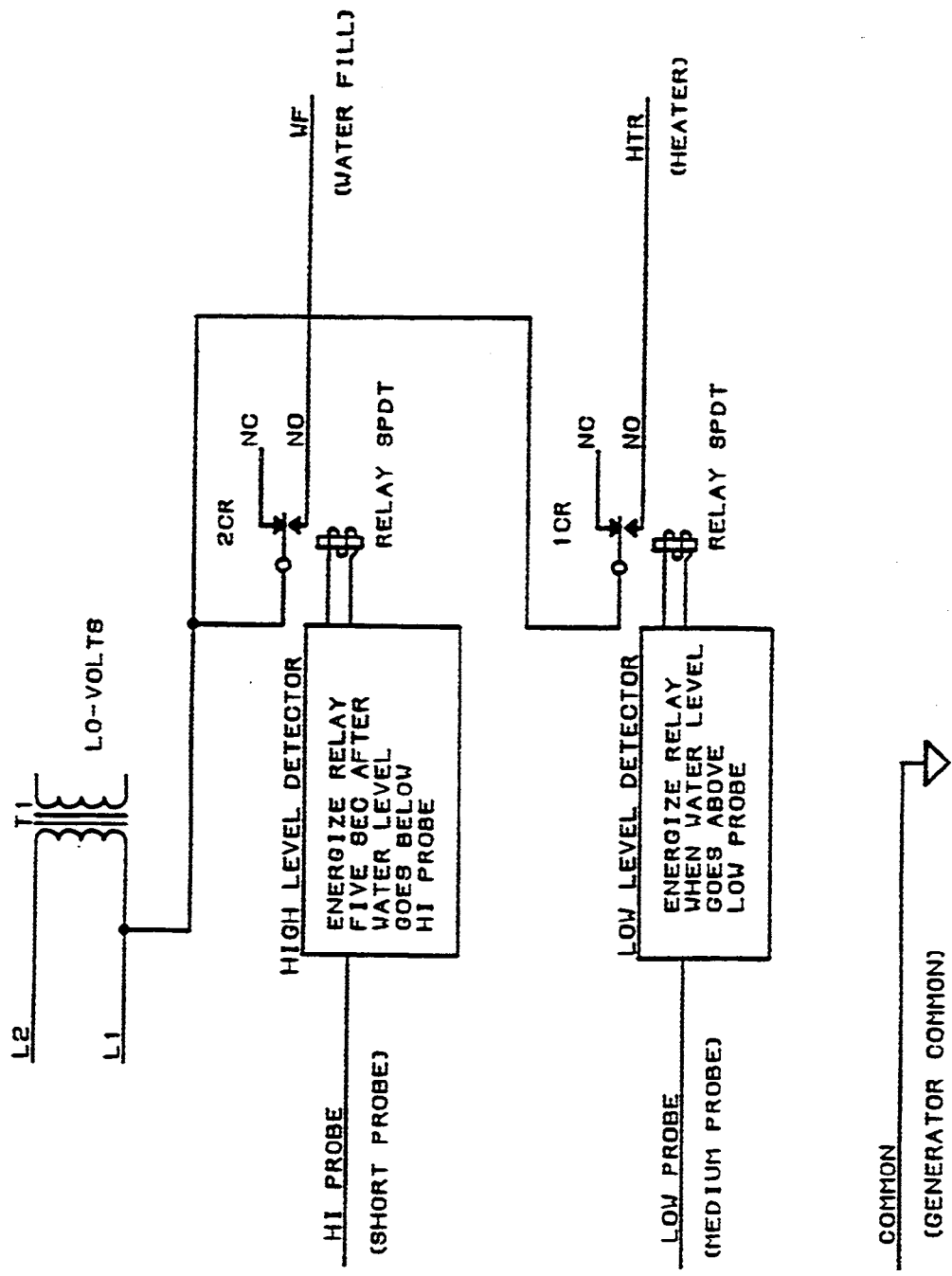

FIGURE 1 TWO-PROBE & COMMON WATER LEVEL CONTROL

<u>STEP</u>	<u>TEST</u>	<u>RESULT</u>	<u>REMEDY</u>
16.	Reconnect one lead of the ohmmeter to the COM wire at the control board and connect the other ohmmeter lead to generator ground. Does the ohmmeter read less than 10 ohms?	Yes	Reconnect HI, LOW & COM wires at control board only. Go to Step #17.
		No	Replace probe wiring
17.	Reconnect the ohmmeter across the LOW terminal at the sensing probe & generator ground. Does the ohmmeter read greater than 100,000 ohms?	Yes	Go to Step #18
		No	Replace probe assembly
18.	Reconnect the ohmmeter across the HI terminal at the sensing probe & generator ground. Does the ohmmeter read greater than 100,000 ohms?	Yes	Go to Step #19
		No	Replace probe assembly
19.	Remove probe and check for scale buildup on or across probes. Replace probe assembly as required.		

TG/drl
02898

<u>STEP</u>	<u>TEST</u>	<u>RESULT</u>	<u>REMEDY</u>
9.	Remove the short from the HI and COM terminals on the control board. Does the AC line voltage between WF and L2 stay at 0 vac for about five seconds, then jump to 120 vac?	Yes	Reconnect HI & COM wires and go to Step #10
		No	Replace water level control P/N 23198
10.	Drain all water form the generator. Disconnect the wires from the LO, HI, & COM terminals at the control board. Connect an Ohmmeter across the LO and COM wires leading to the generator. Does the Ohmmeter read greater than 100,000 ohms?	Yes	Go to Step #12
		No	Go to Step #11
11.	Disconnect the LO wire at the water sensing probe on the generator. Does the Ohmmeter connected in the previous step now read greater than 100,000 ohms?	Yes	Go to Step #12
		No	Replace probe wiring
12.	Reconnect the ohmmeter across each end of the disconnected LO wire. Does the ohmmeter read less than 10 ohms?	Yes	Go to Step #13
		No	Replace wire
13.	Connect an ohmmeter across the HI and COM wires leading to the generator. Does the ohmmeter read greater than 100,000 ohms?	Yes	Go to Step #15
		No	Go to Step #14
14.	Disconnect the HI wire at the water sensing probe on the generator. Does the ohmmeter connected in the previous step now read greater than 100,000 ohms?	Yes	Replace probe wiring
		No	Go to Step #16
15.	Reconnect the ohmmeter across each end of the disconnected HI wire. Does the ohmmeter read less than 10 ohms?	Yes	Go to Step #16
		No	Replace probe wiring

<u>STEP</u>	<u>TEST</u>	<u>RESULT</u>	<u>REMEDY</u>
4.	Are the following connections made correctly?	Yes	Go to Step #5
	A) COM input on board to boiler ground	No	Correct probe wiring as required (see Figure 1)
	B) LO input on board to long length "LO" probe		
	C) HI input on board to short "HI" probe		
5.	Temporarily disconnect the wire from the HTR terminal so that the heat source will not operate. Is the heat source off?	Yes	Go to Step #6
		No	Check heat source and wiring in cooker
6.	With HTR still disconnected, disconnect the LOW wire at the LOW terminal of the control board. Measure the AC line voltage between the HTR and L2 terminals on the control board. Is the voltage 0 vac? NOTE: Digital meters may read a few volts due to their high input impedance; this should be considered as 0 vac.	Yes	Go to Step #7
		No	Replace water level control P/N 23198
7.	Short the LOW and COM terminals on the control board. Does the AC line voltage between the HTR and L2 terminals now read 120 vac (line voltage)?	Yes	Reconnect HTR & LOW wires and go to Step #8
		No	Replace water level control P/N 23198
8.	Disconnect the wires from the HI and COM terminals on the control board and short the HI & COM terminals together. Measure the AC line voltage between the WF and L2 terminals. Is the voltage 0 vac?	Yes	Go to Step #9
		No	Replace water level control P/N 23198

A) SYMPTOMS OF WATER LEVEL CONTROL RELATED PROBLEMS:

- 1) Boiler overfills or floods
- 2) Boiler dry fires (system underfills or doesn't fill)
- 3) Boiler doesn't fill at all
- 4) Water fill solenoid chatter
- 5) Heater contactor chatter
- 6) Fills but cuts out on LOW WATER before filling again
- 7) Overfills but does not heat
- 8) Fills but does not heat

B) POSSIBLE CAUSES:

- 1) Inoperative water level control circuit board (P/N 23198)
- 2) Incorrect or damaged wiring to probes
- 3) Incorrect or damaged wiring from water level board to loads
- 4) Damaged probes
- 5) Probes shorted together
- 6) Scale build-up on probes

C) FAULT ISOLATION PROCEDURE:

Equipment Required: Volt/Ohmmeter (VOM) or Multimeter

<u>STEP</u>	<u>TEST</u>	<u>RESULT</u>	<u>REMEDY</u>
1.	Is power applied to the control circuit board? Measure L1-L2 at the board to be 120 VAC \pm 15V.	Yes	Go to Step #2
		No	Correct external supply problem
2.	Remove two AC power wires from control board and connect ohmmeter to control board power terminals. Is resistance between 100-1000 ohms?	Yes	Reconnect power and go to Step #3
		No	Replace control board P/N 23198 (inoperative transformer)
3.	Visually inspect probe wiring for damaged or broken wires or loose or missing terminals at either end. Is wiring visually OK?	Yes	Go to Step #4
		No	Replace wiring as required

WATER LEVEL CONTROL SYSTEM

TROUBLESHOOTING AND REPAIR

General Description of Operation:

The Cleveland Range water level control, P/N 23I98, is designed to maintain operating water level in Cleveland Range steam generators and to ensure that the heat source is only operated when the generator water level is above a specified minimum level. The sensing technique for the control relies on the fact that tap water is conductive to electricity; if two metal electrodes are immersed in a bath of water, electric current can flow between the electrodes using the water as a conductor. Water is not a good conductor, like copper, but is conductive enough to be measured using appropriate electronic circuitry.

The Cleveland Range control is a two probe system having two metallic probes (LOW and HI) for sensing water in the generator; a COM terminal is placed on the tank. The LOW probe is placed so that it will come in contact with the water when the water level is just above the desired water level, enough to protect the heat source. If the water is of sufficient level and the LOW probe is in the water, a small electrical current provided by the level control electronics will flow between the probe and COM; this flow will be sensed by the electronics which in turn will activate the "HEAT" relay to apply AC power to the HEAT terminal on the control circuit board.

Similarly, the HI probe is located at the desired water level fill (above the LOW probe level) so that when the water level has reached the desired fill level electrical current will flow between the HI probe and COM. The action of this probe is reversed from the previous situation so that when water reaches the HI probe, the WATER fill relay is deactivated so that AC power to the WF is turned off. When the water level drops below the HI probe, the WF terminal will be re-energized after a five second delay. The time delay is to prevent bubbling or turbulence in the generator from chattering to WATER fill relay or the water valve solenoid.

The control runs on 120 vac and is transformer isolated so that the probes and the electronics are run at low voltage and are not common to the AC power line.

Note that in many Cleveland Range generators both sensing probes are inserted from the front top of the unit down into the generator. In this case, the LOW probe will be the longest and the HI probe will be the shortest.

Descaling Procedure (continued)

5. Turn off power at main disconnect switch.
6. Remove handhole plate.
7. Pour powdered sulfamic acid into the steam generator.
8. Replace handhole plate.
9. Turn water off at manual 1/4-inch ball valve on base.
10. Remove control box cover.
11. Disconnect black probe wire from water board.
12. Turn power on at the main disconnect switch.
13. Turn POWER switch on base unit to on.
14. Turn water on at manual 1/4-inch ball valve.
15. Let steam generator fill to proper level (2/3 the way up the sight glass), then turn off the manual fill valve to stop generator fill.
16. Start steam generator heat cycle. Let generator heat up until it is hot to the touch.
17. When the steam generator is hot turn off the gas package valve.
18. Turn on the generator fill manual valve and, while holding open the safety valve (pop off valve), let the generator keep filling until water comes out the safety valve.
19. Turn off the manual ball valve to the fill assembly.
20. Let steam generator descale overnight or for any eight (8) hour period.
After eight hour period:
21. Drain the generator with the manual 3/4-inch ball valve.
22. Turn off electric power at the main disconnect switch.
23. Remove handhole plate.
24. Pour in neutralizer (3 or 4 tablespoons of baking soda).
25. Install handhole plate and tighten the bar and nut assembly to a maximum of 15 foot pounds torque.
26. Close the 3/4-inch manual drain valve.
27. Open 1/4-inch manual ball valve to fill assembly.
28. Turn electrical power on at main disconnect switch.
29. Turn POWER switch on base unit to on.
30. Let unit fill until water comes out the safety valve.
31. Close 1/4-inch manual ball valve on fill assembly.
32. Let unit set for 5 minutes.
33. Open the 3/4-inch drain valve to blow down and drain the steamer.
34. Turn POWER switch on base unit to off.
35. Turn power off at the main disconnect switch.
36. Reconnect black probe wire to water board.
37. Replace control box cover.
38. Turn on manual ball valve to fill assembly.
39. Close 3/4-inch drain ball valve.
40. Turn power on at the main disconnect switch.
41. Turn POWER switch on base unit to on.
42. An amber light on the STEAM switch will light when the water reaches the low cut-off probe.
43. Turn on the STEAM switch to start the steam generator for a test.
44. When pressure reaches 9 psi on the pressure gage located on the steam generator console, open the manual drain valve to blow down the generator under pressure and test the low water cut-off.
45. Close the manual drain valve.
46. Refill generator and when amber light comes on, turn on the steam switch to start the steam generator for a test.
47. When the unit reaches 9 psi, turn off POWER switch on console to test blowdown.
48. After blowdown has completed, refill generator and restart heat cycle.
49. Unit is now ready for use.

Descaling Procedure for Two-Probe Steam Generators

The steam generator should be descaled at least once a month, depending on scale buildup. If you have serious steam generator scale buildup, install a water treatment system for the steamer. Cleveland Range recommends use of the descaling kit, part number 40891, which consists of powdered sulfamic acid. Full descaling may take several hours, or more than one acid process. Perform descaling until all scale buildup is cleaned out.

Follow hazard and leak cleanup procedures on acid container label. If the label is not readable or has been removed, refer to the following hazard and emergency instructions as a minimum safety precaution.

THESE INSTRUCTIONS ARE FOR USE WITH POWDERED SULFAMIC ACID ONLY.

- **Health Hazard Data, Effects of Overexposure** - Product is extremely irritating to the eyes and may result in eye burns. Product is severely irritating to skin and can result in skin burns; repeated or prolonged contact with more dilute solutions may result in dermatitis. Aerosol mist or vapors are irritating to respiratory tract, eyes and throat. Prolonged exposure to high concentration may result in pulmonary edema. If ingested, may result in abdominal hemorrhage with severe abdominal pain, nausea, vomiting or loss of consciousness; necrosis of stomach and gastrointestinal tract may also occur.
- **Emergency and First Aid Procedures** - In case of eye contact, immediately flush eyes with plenty of water for at least 15 minutes. Seek medical aid. In case of skin contact immediately wash with soap and plenty of water for at least 15 minutes while removing contaminated clothing. Seek medical aid. If inhaled, remove to fresh air. If not breathing, give artificial respiration. If breathing is difficult, give oxygen. Seek medical aid. If swallowed, do not induce vomiting. Give large quantities of water. Seek medical aid. Never give anything by mouth to an unconscious person.
- **Spill or Leak Procedures** - Contain spill. Cover the contaminated surface with sodium bicarbonate or a soda ash-slaked lime mixture

(50-50). Mix and add water if necessary to form slurry. Scoop up slurry and wash residue down drain with excess water. Wash site with soda ash solution.

WARNING

The powdered sulfamic acid in descaling kit 40891 can be harmful if not handled properly. Follow these basic safety rules for handling and using acid.

Wear protective clothing when mixing or applying chemical cleaners. Wear rubber gloves, mask and approved cup-type goggles.

Avoid breathing fumes. If acid comes in contact with skin, flush immediately with large quantities of cold water. Remove contaminated clothing.

If chemical contacts eyes, flush with cold water for a minimum of 15 minutes. Get immediate medical attention.

If chemical is swallowed or ingested, follow instructions on the chemical container. Get immediate medical attention.

CAUTION

Do not scrape heating elements with a solid tool.

If the steamer is turned off, energize the steamer by pressing the POWER switch to on. Allow time for the steam generator to fill (3 to 4 minutes). This assures that blowdown occurs.

1. Press the POWER switch to off.
2. Press the TIMED/MANUAL switch to TIMED. Set timer to 0.
3. After completion of blowdown (3 minutes), turn off power at the main disconnect switch.
4. Allow time for the steam generator and compartment to cool down.

WATER QUALITY REQUIREMENTS — 2-PROBE TYPE STEAM GENERATOR PROTECTION AND MAINTENANCE

A steam generator, or boiler, unlike other types of water-using kitchen equipment, distills the water in order to make steam. Nearly all feed-water sources contain dissolved minerals in varying degrees of concentration. As this water is boiled, pure steam rises from its surface, upward to the cooking compartment(s), leaving minerals behind, that can become harmful to the steam generator. If minerals are allowed to accumulate inside the steam generator, they will solidify as a scale. Then, malfunctioning will occur, and serious equipment damage may result.

The use of good quality generator feed water is the responsibility of the owner/user. The use of poor quality feed water could void equipment warranties. The minimum treatment required in most areas is water softening, although local water conditions may require more intensive pretreatment than simply a water softener.

Scale problems occur when feed water is high in hardness, total dissolved solids, silica, and alkalinity. Water softening will only reduce the water's hardness, which is the presence of dissolved salts of magnesium and calcium. Water softening will not affect the multitude of other minerals found in most water supplies. Because generator scale is the result of the precipitation of many minerals, the best property to control, for generator feed water, is total dissolved solids, not just hardness.

The recommended minimum water quality standards, whether untreated or pre-treated, based upon 8 hours of use per day, and a Daily Blowdown, are as follows:

TOTAL DISSOLVED SOLIDS	less than	60 parts per million
TOTAL ALKALINITY	less than	27 parts per million
SILICA	less than	13 parts per million
PH FACTOR	greater than	7.5

Consult the state department of water or a local water treatment specialist for an on-the-premises water analysis and for recommendations concerning steam generator feed water treatment (if required), in order to remove or reduce harmful concentrations of minerals.

If the recommended water quality requirements are met without supplemental treatment, or if treatment is applied, resulting in feed water quality meeting the prescribed standards, the steam generator will need to be blown down only once every 8 hours. In addition, the inside of the generator requires an inspection (for excessive lime accumulation) only once every six months. Chemically descale the generator as required.

If a pre-treatment unit cannot be installed, and the recommended water quality requirements are not met, the following procedures should be followed, in order to achieve maximum steam generator service life. The steam generator should be blown down after each 4-6 hours of use. Have the steam generator inspected, inside and outside, by a qualified technician every three months. If the inside of the generator is heavily coated with scale, have it chemically descaled by a qualified service technician.

INSTRUCTIONS FOR CHEMICALLY DESCALING 2-PROBE TYPE STEAM GENERATORS

WARNING: Steam under pressure may cause serious injury and bodily harm when it is accidentally or carelessly released. Improper handling of acid could cause serious, permanent injury. Therefore, service of the steam generator should only be performed by trained and experienced personnel, thoroughly familiar with servicing generators.

There are a number of commercial descaling chemicals available, produced by various manufacturers. Those utilizing a sulfamic acid base, which can be identified by its powdered form, are safe and compatible with our food preparation equipment. It is imperative that the acid used for descaling be FDA approved, for use in food preparation equipment. Various manufacturers may include additional chemicals to increase potency, and therefore, instructions for a specific brand should be followed carefully. If instructions are not provided with the deliming chemical you purchase, the following general guidelines may be followed.

WARNING: Exercise care when handling acid. Avoid contact with skin, eyes, or clothing. Wear safety glasses or face shield, along with rubber gloves and rubber apron. In case of exposure to clothing, remove clothing and flush with water. In case of exposure to skin or eyes, flush with water for 15 minutes and get immediate medical attention. Do not take internally. Keep out of the reach of children.

Be sure the generator has been drained, de-pressurized, and is cool. Open the hand hole access plate on the front of the generator and place approximately 8-10 pounds of sulfamic acid inside the generator. Put a new hand hole gasket on the hand hole plate, and replace the hand hole plate, tightening the bar and nut assembly to a maximum of 15 foot pounds torque. The generator must be completely filled with water (fill the generator beyond its normal, automatic fill point of 2/3 up in the sight gauge). This can be accomplished by temporarily disconnecting the wire from the water level probe at the water level control board. The board is marked "HI" at this connection point. Turn the main on-off rocker switch to the "ON" position, then close the manual water feed valve when the generator is completely filled. Leave the on-off rocker switch in the "on" position to prevent the generator from automatically draining. Reconnect the probe wire to the "HI" terminal of the water level control board. Let the solution stand for several hours, then flush with water. Rinse with a solution of bicarbonate of soda to neutralize any acid residue, and again, flush with water. Be sure to reconnect the wire to the water level control board and to open the manual water feed valve.

CAUTION: Never tighten the hand hole plate nut when the steam generator is in use, hot, or otherwise pressurized. Never tighten nut over 15 foot-pounds torque. Overtightening may cause uneven stress, which may result in the weakening and possible breakage of the plate.

CLEVELAND RANGE, INC., 1333 EAST 179th ST., CLEVELAND, OHIO 44110

STEAM GENERATOR (2 PROBE TYPE) MAINTENANCE PROCEDURES

CAUTION: Service on the generator must be performed only by a trained and experienced service technician, thoroughly familiar with servicing steam generators. No work should be done on the steam generator while it is pressurized or hot. Be sure all energy sources are shut off before the start of any work.

The steam generator must be drained under pressure (blowdown) after a maximum of 8 hours of use. If the generator's feedwater contains more than 300 parts per million of total dissolved solids, the generator must have a blowdown after each 4-6 hours of use. "Blowdown" means the generator must be drained under pressure.

THE GENERATOR "BLOWDOWN" IS PERFORMED BY SHUTTING OFF THE UNIT'S RED-LIGHTED "POWER" SWITCH WHILE THE GENERATOR IS AT NORMAL OPERATING PRESSURE. WHEN THE BOTTOM OF THE "POWER" ROCKER SWITCH IS PUSHED, ITS RED LIGHT GOES OUT, AND THE DRAIN VALVE AUTOMATICALLY OPENS, DRAINING THE GENERATOR. AN AUTOMATICALLY-TIMED SOLENOID VALVE WILL FLUSH THE DRAIN FOR 3 MINUTES, THEN SHUT OFF. AFTER 3 MINUTES, THE UNIT CAN BE RESTARTED.

Even though the "Blowdown" is performed faithfully each day, it will still be necessary to have a qualified service technician periodically inspect the inside of the generator for scaling or pitting. The generator's hand hole plate should be removed at regular intervals, so that it and the inside of the generator can be inspected. The hand hole plate should be cleaned and examined each time it is removed. If the hand hole plate is chipped or cracked, or over three years old, install a new one. A new hand hole gasket should always be installed.

Scaling indicates a high concentration of dissolved minerals in the feed water. Pitting indicates an excess acid condition. The best way to reduce servicing time and to assure a long generator life is to provide feed water that is low in mineral content and low in gas content. Water that is fit to drink can still be high in impurities that are highly detrimental to a steam generator. Consult the state department of water for an on-the-premises water analysis and for recommendations concerning steam generator feed water treatment (if required), in order to remove or reduce harmful concentrations of minerals.

CAUTION: Never tighten the hand hole plate nut when the steam generator is in use, hot, or otherwise pressurized. Never tighten nut over 15 foot-pounds torque. Overtightening may cause uneven stress, which may result in the weakening and possible breakage of the plate.

The "Blowdown" procedure will not completely remove the mineral deposits that adhere to the top of the generator.

It will be necessary to periodically have scale accumulations removed from the inside of the steam generator by a qualified service technician. Only a U.S.D.A. approved acid cleaner should be used to descale the generator.

Descaling should be done once a year, but in poor water (highly mineralized) areas it may be needed two or three times a year.

Failure to periodically remove scale from the inside of the generator will result in greatly reduced generator life.

Check the safety valve once a month while the steam generator is pressurized. Test by pulling the safety valve lever. The valve must open freely and snap closed when released. If it does not, or if it drips constantly, a new safety valve is needed.

If the steam generator is to be left idle for three months or more, it should be drained and dried out and the hand hole plate left off.

CLEVELAND RANGE, INC., 1333 EAST 179th ST., CLEVELAND, OHIO 44110

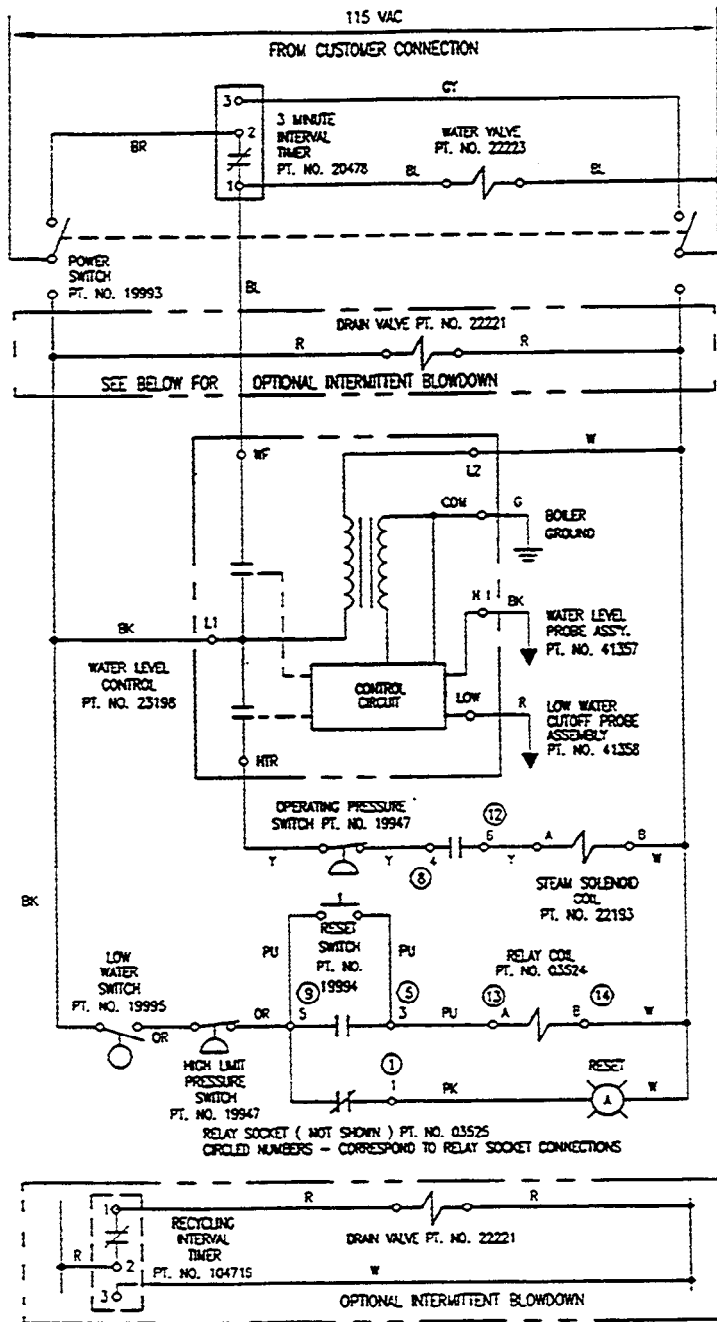

STEAM COIL GENERATOR CONTROL WIRING
SECONDARY LOW WATER CUTOFF
(INTERMITTENT BLOWDOWN OPTIONAL)

Steam Coil Models with Secondary Low Water Cutoff

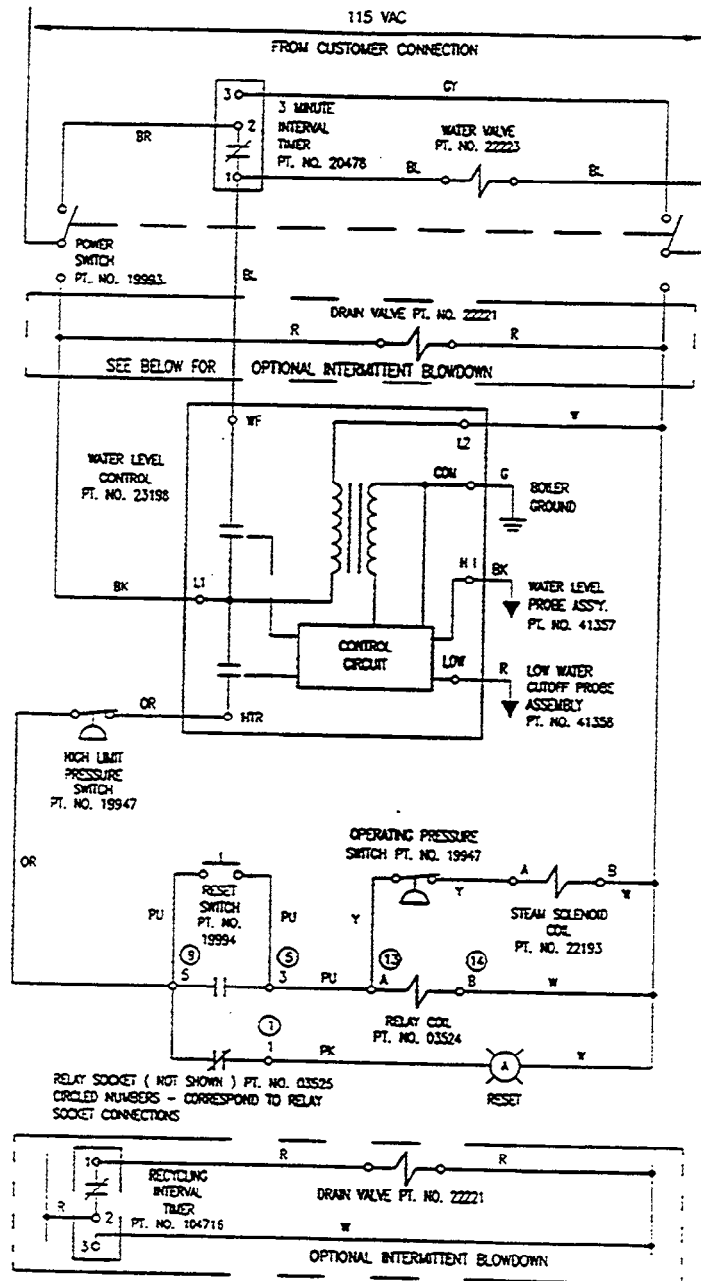

STEAM COIL GENERATOR CONTROL WIRING
 (INTERMITTENT BLOWDOWN OPTIONAL)

STEAM COIL GENERATOR (BOILER) ASSEMBLY 2 PROBE TYPE

REFERENCE NUMBER	PART NUMBER	DESCRIPTION
1	43977	Steam Coil Boiler Shell with Legs, Sight Gauge, Steam Coil, Hand Hole Plate Assembly, 2 Probes and Extensions with Cover Box.
2	100636	Hand Hole Plate Assembly
2a	16545	Hand Hole Plate Only
3	07116	Hand Hole Gasket
4	40401	Steam Coil Assembly
5	14612	1¼" Brass Locknut
6	23135	¾" Square Flat Washer
7	14611	1¼" Steel Locknut
8	40446	Water Gauge Set with Glass
	07108	Fibre Washer (2 required)
	23132	Gauge Glass Washer (2 required)
9	07301	Glass Only—10½" Long
10	52305	Probe Cover Box
11	40462	Probe with Lockwasher and Screw
12	101466	Probe Extension Set (2)
13	22130	Safety Valve—8 psi
	22131	Safety Valve—15 psi
14	22232	Safety Valve—55 psi
15	03277	¾" Ball Valve
16	22193	¾" Steam Solenoid Valve
17	19872	¾" Line Strainer
18	20555	¾" Bucket Trap
19	19870	¼" Line Strainer
20	06226	Brass Elbow, 90°, Special
21	22223	Solenoid Valve, Water Feed
22	22102	Check Valve, ¼"
23	03276	¼" Ball Valve, Water Supply Shut Off
24	22221	Solenoid Valve, Boiler Drain
25	03277	¾" Ball Valve, Manual Drain
26	03616	Reducing Bell
27	13252	Drain Manifold
28	05292	Street Elbow, 90°
29	05238	Elbow, 90°
30	23198	Control Board, Water Level and LWCO
31	44165	Terminal Block, 4-pole
32	03525	Relay Socket
33	03524	Relay
34	20478	Interval Timer, 3 Minute
35	19947	Pressure Switch
36	19993	DPDT Power Switch
37	19994	SPST Momentary Contact Reset Switch
38	07168	Pressure Gauge, Back Mount, 0-30 psi
39	07166	Pressure Gauge, Back Mount, 0-100 psi
40	45006	Low Water Cut Off Assembly (California Only)
41	41943	LWCO Mounting Plate (California Only)
42	07128	Gasket (California Only)
43	05253	Brass Street Elbow (California Only)
44	02623	½"-¼" Brass Reducing Bushing (California Only)
45	19995	Float Switch, LWCO (California Only)

STEAM COIL GENERATOR (BOILER) ASSEMBLY 2 PROBE TYPE

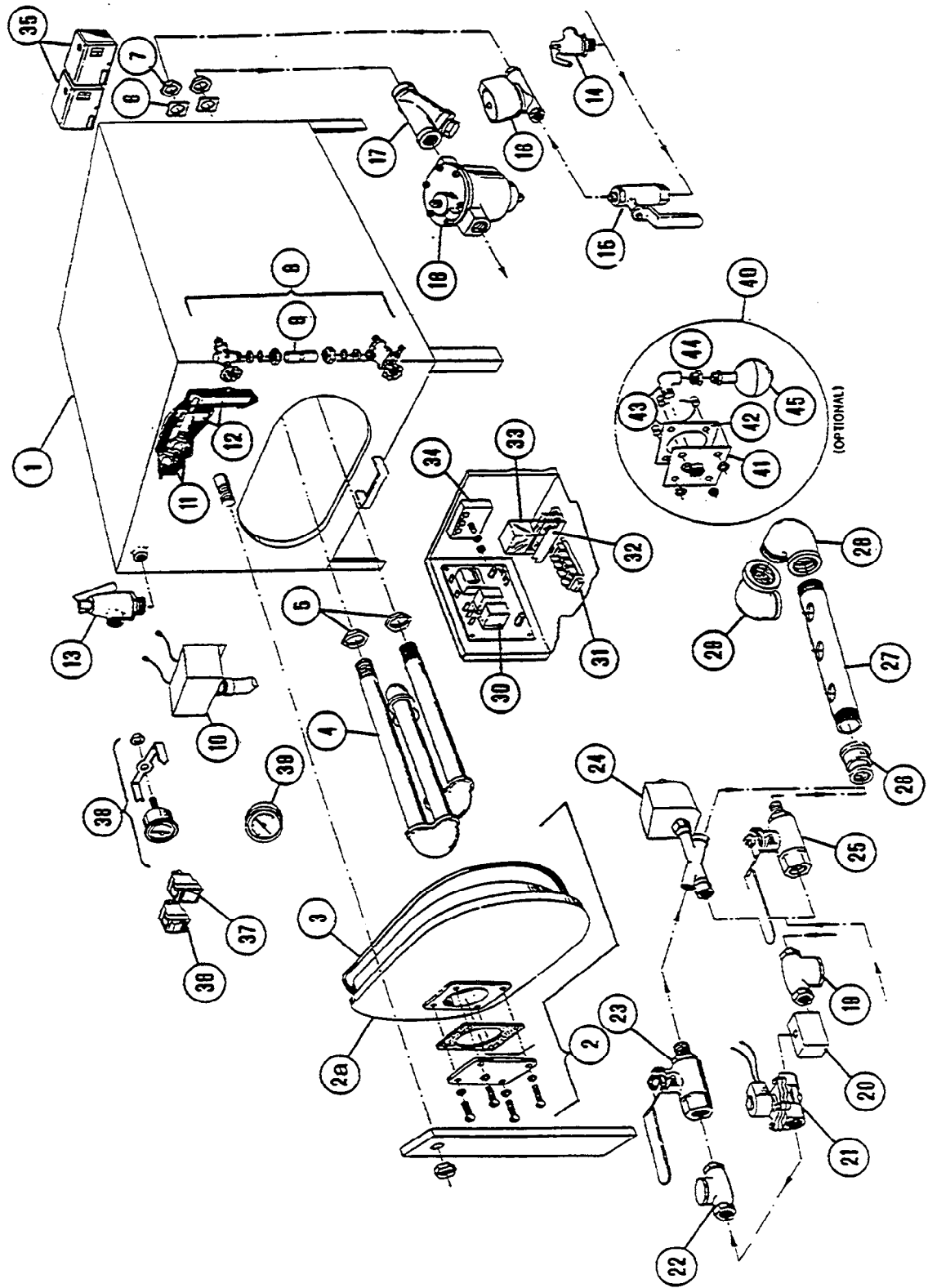

Manufacturer reserves right of design improvement or modification, as warranted.

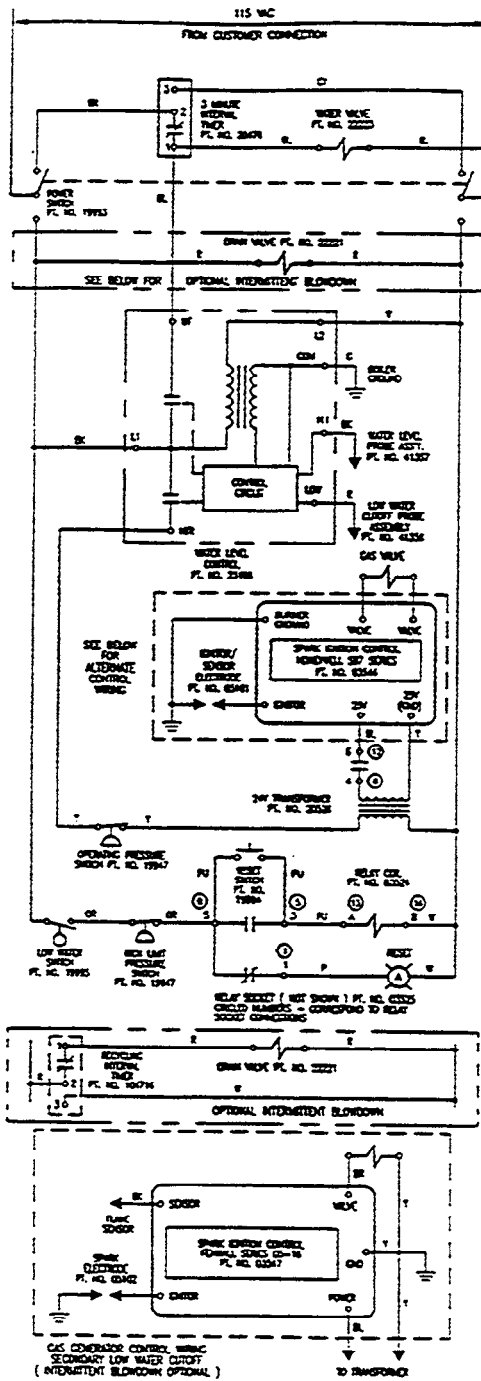

Gas Models with Secondary Low Water Cutoff

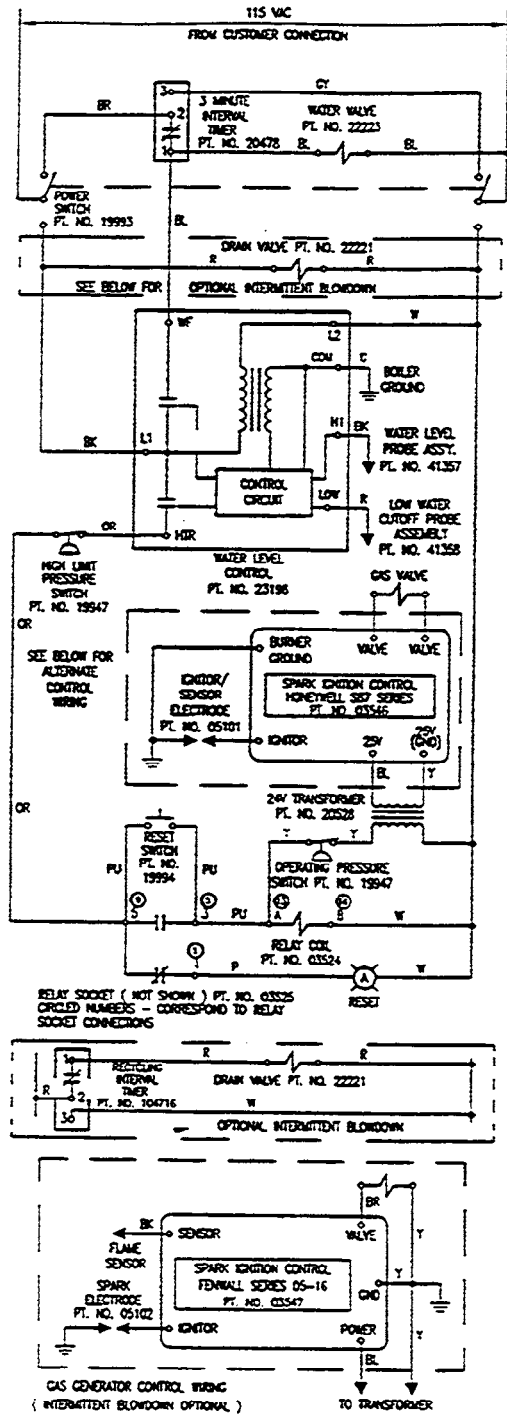

Gas Models

GAS STEAM GENERATOR (BOILER) ASSEMBLY - 2 PROBE TYPE
SMALL: 100,000 BTU (2 Burners) & 200,000 BTU (4 burners)
LARGE: 250,000 BTU (5 burners) & 300,000 BTU (6 burners)

REFERENCE NUMBER	PART NUMBER	DESCRIPTION	REFERENCE NUMBER	PART NUMBER	DESCRIPTION
1	43898	Small boiler shell only (100,000/200,000 BTU), with legs, studs, hand hole plate assembly and top flue bracket.		44156	5-burner rear burner support
	43899	Large boiler shell only (250,000/300,000 BTU), with legs, studs, hand hole plate assembly, and top flue bracket.	15	22130	Safety valve, 8 psi
	44173	Small boiler shell (43898) above, also including insulation panels, top flue collector with insulation, sight gauge, two probes and extensions with cover box.	16	22131	Safety valve, 15 psi
	44172	Large boiler shell (43899) above, also including insulation panels, top flue collector with insulation, sight gauge, two probes and extensions with cover box.	17	19947	Pressure switch
				22228	Gas control valve, natural gas, small boiler (100,000/200,000 BTU)
				22230	Gas control valve, natural gas, large boiler (250/300,000 BTU)
				22231	Gas control valve, L.P. gas, small and large boilers (100,000/200,000 and 250,000/300,000 BTU)
2	40421	Hand hole plate assembly including bar, nut, and gasket.	18	44169	Ignitor cable
2a	43748	Hand hole plate only	19	44096	Ignitor box assembly with ignitor
3	07106	Hand hole gasket, 4" x 6" oval	20	05101	Ignitor electrode
4	40462	Probe	21	40918	Gas manifold, 2-burner
5	101466	Probe extension set (set of two)		40920	Gas manifold, 4-burner
6	52305	Probe cover box		40921	Gas manifold, 5-burner
7	40445	Water gauge set with glass	22	40922	Gas manifold, 6-burner
	07108	Fibre washer (2 required)	22	52602	Manifold alignment bracket
	23132	Gauge glass washer (2 required)	23	19632	Orifice holder
8	07302	Gauge glass only, 6" long	24	15453	Burner orifice, natural gas
9	44043	Left side insulation panel assembly		15450	Burner orifice, L.P. gas
	440431	Left side insulation panel assembly for L.P. gas - 100,000/200,000 BTU boiler only	25	02497	Burner
10	44042	Right side insulation panel assembly	26	03546	Spark ignition control module
	440421	Right side insulation panel assembly for L.P. gas - 100,000/200,000 BTU boiler only	27	20528	24 volt transformer
11	42398	Top flue collector with insulation, for small boiler (100,000/200,000 BTU)	28	20478	Interal timer, 3 minute
	42399	Top flue collector with insulation, for large boiler (250,000/300,000 BTU)	29	44164	Terminal block, 4 pole
	42360	Internal flue riser assembly for small boiler (100,000/200,000 BTU)	30	03525	Relay socket
	42361	Internal flue riser assembly for large boiler (250,000/300,000 BTU)	31	03524	Relay
13	44134	2-burner front baffle assembly - natural gas	32	23198	Control board, water level and IWCO
	44135	4-burner front baffle assembly - natural gas	33	22102	Check valve, 1/4"
	40840	5-burner front baffle assembly - natural gas	34	03276	1/4" Ball valve, water supply shut off
	40842	6-burner front baffle assembly - natural gas	35	22223	Solenoid valve, water feed
	44150	Front burner baffle assembly for L.P. gas - 100,000/200,000 BTU boiler only (not shown)	36	19870	Line strainer, 1/4"
	44170	Right side burner baffle assembly for L.P. gas - 100,000/200,000 BTU boiler only (not shown)	37	03277	3/4" Ball valve, manual drain
	44171	Left side burner baffle assembly for L.P. gas - 100,000/200,000 BTU boiler only (not shown)	38	22221	Solenoid valve, boiler drain
14	44153	2-burner rear burner support	39	13252	Drain manifold
	44155	4-burner rear burner support	40	45006	Low water cut-off assembly (California only)
			41	41943	LWCO mounting plate (California only)
			42	07128	Gasket (California only)
			43	05253	Brass street elbow (California only)
			44	02623	1/2" - 1/4" Brass reducing bushing (California only)
			45	19995	Float switch, IWCO (California only)
			46	19993	DPDT Power switch
			47	19994	SPST Momentary contact reset switch
			48	07167	Pressure gauge, 0-30 psi, 1 1/2"

Manufacturer reserves right of design improvement or modification, as warranted.

GAS STEAM GENERATOR (BOILER) ASSEMBLY - 2 PROBE TYPE
SMALL: 100,000 BTU (2 Burners) & 200,000 BTU (4 burners)
LARGE: 250,000 BTU (5 burners) & 300,000 BTU (6 burners)

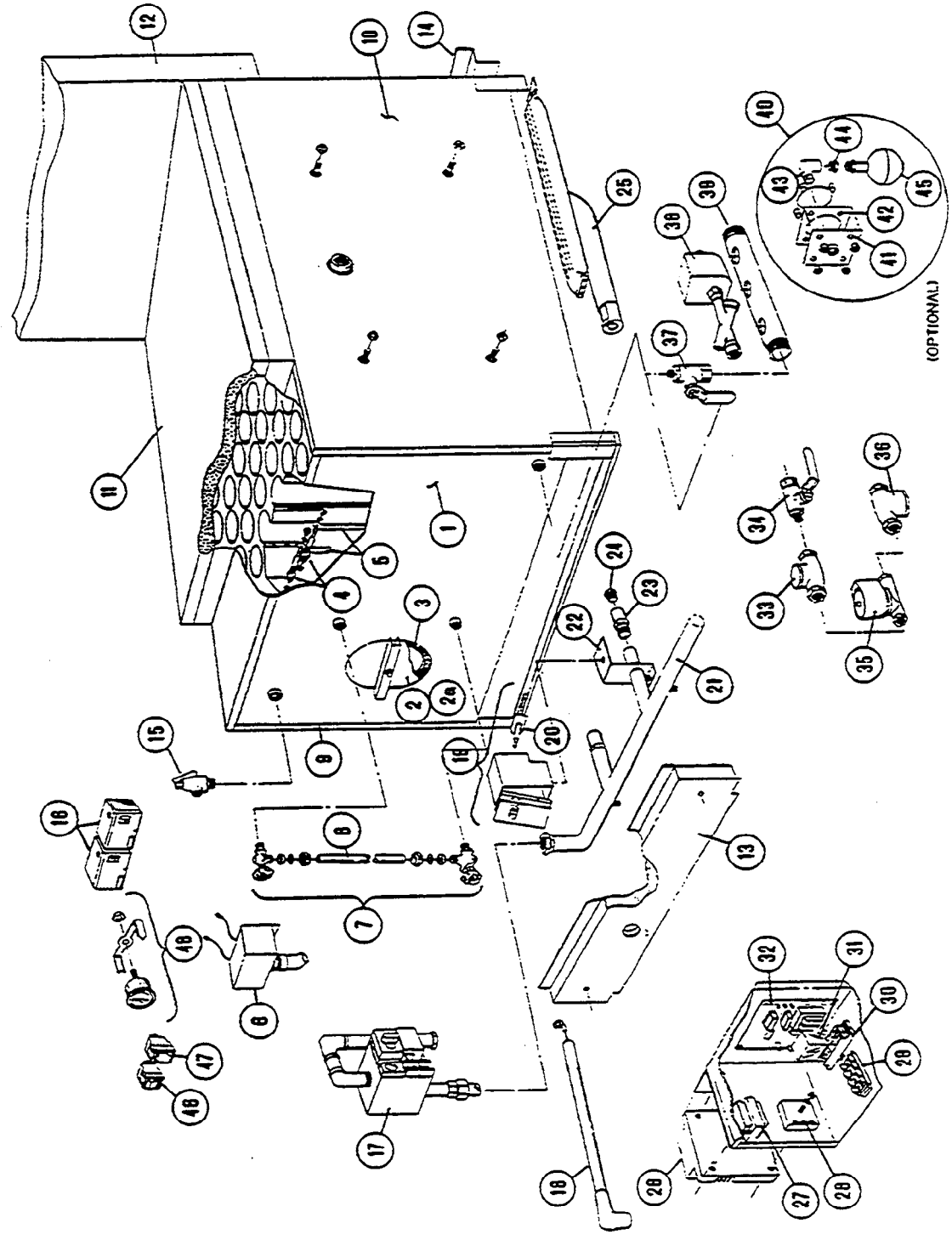

Manufacturer reserves right of design improvement or modification, as warranted.

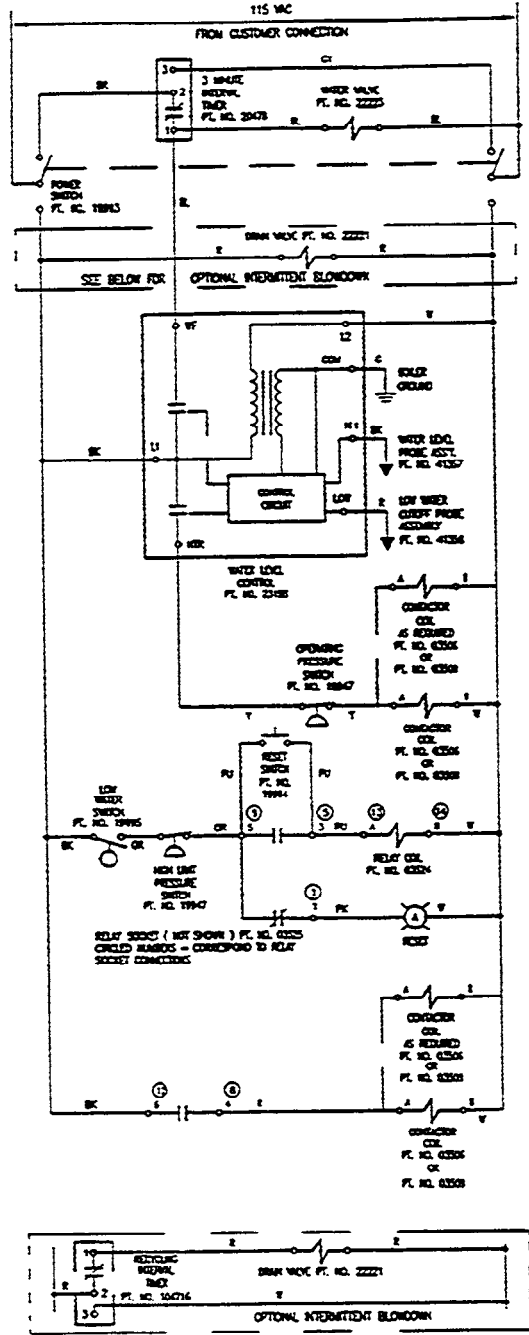

ELECTRIC GENERATOR CONTROL, WISMC
 CALIFORNIA CODE
 (INTERMITTENT BLOWDOWN OPTIONAL)

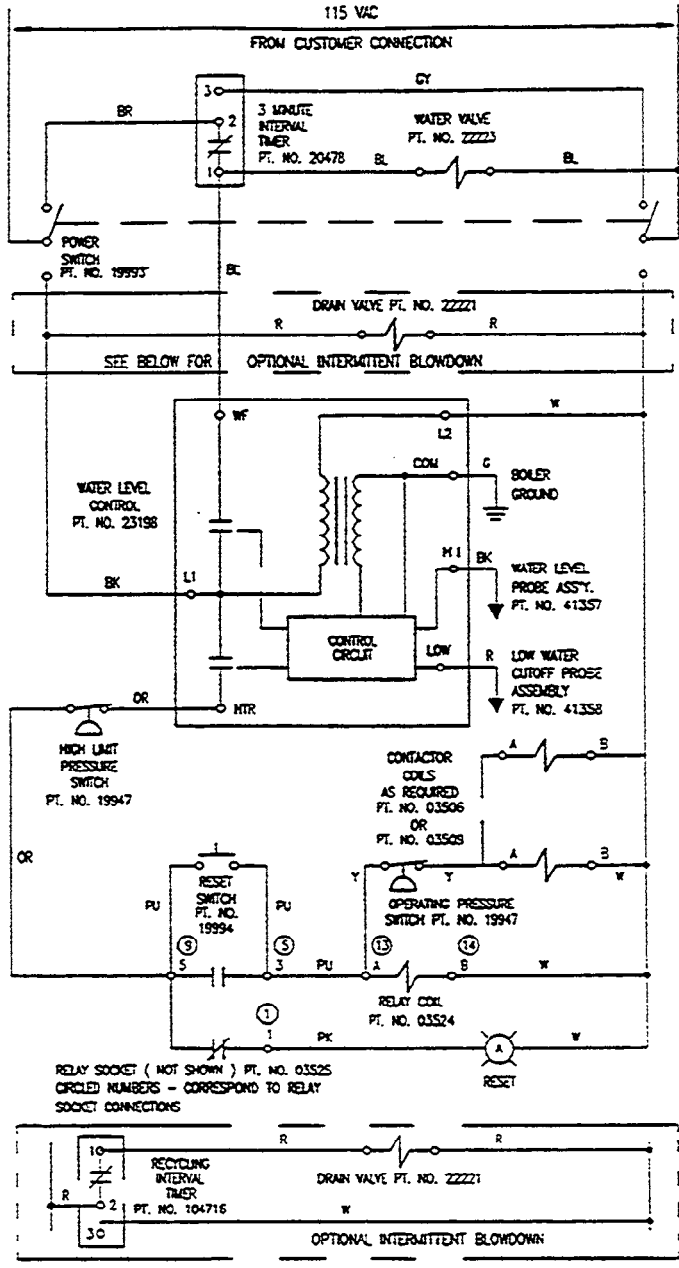

ELECTRIC GENERATOR CONTROL WIRING
 (INTERMITTENT BLOWDOWN OPTIONAL)

HEATER AND CONTACTOR WIRING SCHEMATICS FOR SOLID STATE ELECTRIC STEAM GENERATORS

<p>100W-200V, 220V & 240V-1 PHASE</p> <p>1-HEATER</p>	<p>200W-200V, 480V-3 PHASE</p> <p>1-HEATER</p>																																																							
<p>100W-200V, 480V-1 PHASE</p> <p>2-HEATER</p>	<p>100W-200V, 200V, 240V, 480V-3 PHASE</p> <p>1-HEATER</p>																																																							
<p>270W-200V, 200V, 240V, 480V-3 PHASE</p> <p>2-HEATER</p>	<p>100W-200V, 200V, 240V, 480V-3 PHASE</p> <p>1-HEATER</p>																																																							
<p>270W-200V, 200V, 240V, 480V-3 PHASE</p> <p>2-HEATER</p>	<p>100W-200V, 200V, 240V, 480V-3 PHASE</p> <p>1-HEATER</p>																																																							
<p>270W-200V, 200V, 240V, 480V-3 PHASE</p> <p>2-HEATER</p>	<p>100W-200V, 200V, 240V, 480V-3 PHASE</p> <p>1-HEATER</p>																																																							
<p>270W-200V, 200V, 240V, 480V-3 PHASE</p> <p>2-HEATER</p>	<p>100W-200V, 200V, 240V, 480V-3 PHASE</p> <p>1-HEATER</p>																																																							
<p>ELECTRIC POWER</p> <table border="1" style="margin-left: auto; margin-right: auto; border-collapse: collapse;"> <thead> <tr> <th colspan="2"></th> <th colspan="4">3 PHASE</th> <th>1 PHASE</th> </tr> <tr> <th colspan="2"></th> <th>10</th> <th>27</th> <th>56</th> <th>68</th> <th>18</th> </tr> </thead> <tbody> <tr> <td rowspan="2">200V</td> <td>AMP</td> <td>50</td> <td>75</td> <td>100</td> <td>110</td> <td>87</td> </tr> <tr> <td>PER</td> <td>40</td> <td>60</td> <td>80</td> <td>120</td> <td>80</td> </tr> <tr> <td>230V</td> <td>LINE</td> <td>—</td> <td>—</td> <td>—</td> <td>110</td> <td>—</td> </tr> <tr> <td>240V</td> <td></td> <td>44</td> <td>65</td> <td>87</td> <td>110</td> <td>75</td> </tr> <tr> <td>440V</td> <td></td> <td>20</td> <td>30</td> <td>40</td> <td>53</td> <td>35</td> </tr> <tr> <td>480V</td> <td></td> <td>22</td> <td>33</td> <td>44</td> <td>58</td> <td>38</td> </tr> </tbody> </table> <p style="text-align: center; font-size: small;">FOR POWER SUPPLY CONNECTIONS USE COPPER WIRE ONLY, SUITABLE FOR AT LEAST 75°C.</p>				3 PHASE				1 PHASE			10	27	56	68	18	200V	AMP	50	75	100	110	87	PER	40	60	80	120	80	230V	LINE	—	—	—	110	—	240V		44	65	87	110	75	440V		20	30	40	53	35	480V		22	33	44	58	38
		3 PHASE				1 PHASE																																																		
		10	27	56	68	18																																																		
200V	AMP	50	75	100	110	87																																																		
	PER	40	60	80	120	80																																																		
230V	LINE	—	—	—	110	—																																																		
240V		44	65	87	110	75																																																		
440V		20	30	40	53	35																																																		
480V		22	33	44	58	38																																																		

ELECTRIC STEAM GENERATOR (BOILER) ASSEMBLY - 2 PROBE TYPE

18 KW, 27 KW, 36 KW, & 48 KW (2, 3, & 4 HEATER ELEMENTS)

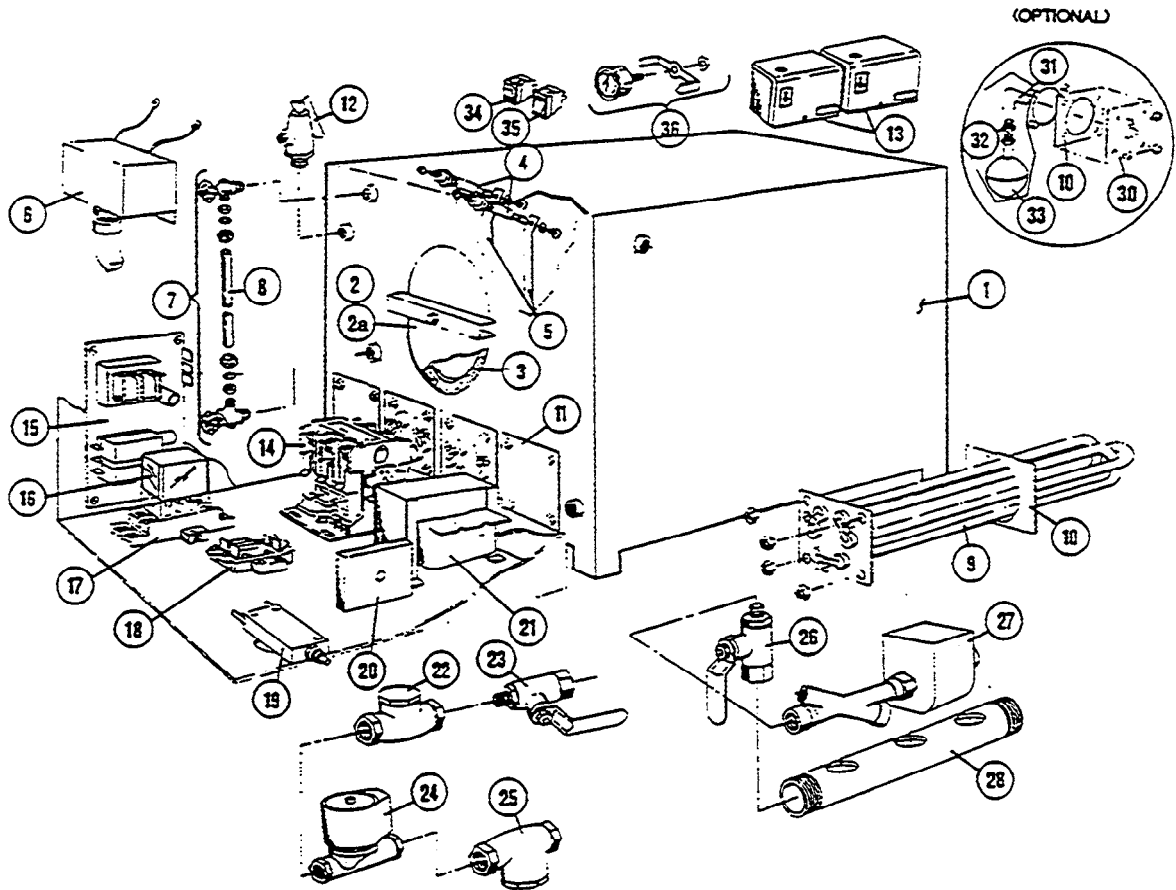

REFERENCE NUMBER	PART NUMBER	DESCRIPTION	REFERENCE NUMBER	PART NUMBER	DESCRIPTION
1	43894	Electric Boiler Shell only, with legs, hand hole plate assembly, mounting studs for 3" square-flanged heater elements		08216	Heater, 12 KW, 440/480 volt, 1 phase
	44149	Electric Boiler Shell (43894) above, also including sight gauge, two probes and extensions with cover box.	10	08217	Heater, 12 KW, 600 volt, 1 phase
2	40421	Hand Hole Plate Assembly including bar, nut, and gasket.	11	07128	Heater Gasket
2a	43748	Hand Hole Plate only	12	16546	3" Block-Off Plate
3	07106	Hand Hole Gasket, 4" x 6" oval	13	22131	15 psi Safety Valve
4	40462	Probe	14	22130	8 psi Safety Valve
5	101466	Probe Extension Set (set of two)	15	19947	Pressure Switch
6	52305	Probe Cover Box	16	03509	Contactor, 50 amp
7	40445	Water Gauge Set with Glass	17	03506	Contactor, 75 amp
	07108	Fibre Washer (2 required)	18	23198	Control Board, water level and LWCO
	23132	Gauge Glass Washer (2 required)	19	03524	Relay
8	07302	Gauge Glass Only, 6" long	20	03525	Relay Socket
9	08235	Heater, 9 KW, 208 volt, 3 phase	21	44168	Terminal Block, 2 pole
	08236	Heater, 9 KW, 220/240 volt, 3 phase	22	03202	Circuit Breaker, 1 amp
	08237	Heater, 9 KW, 440/480 volt, 3 phase	23	20478	Interval Timer, 3 minute
	08234	Heater, 9 KW, 600 volt, 3 phase	24	20535	Transformer, 150 VA
	08241	Heater, 9 KW, 208 volt, 1 phase	25	22102	Check Valve, 1/4"
	08242	Heater, 9 KW, 220/240 volt, 1 phase	26	03276	1/4" Ball Valve, water supply shut-off
	08243	Heater, 9 KW, 440/480 volt, 1 phase	27	22223	Solenoid Valve, water feed
	08244	Heater, 9 KW, 600 volt, 1 phase	28	19870	Line Strainer, 1/4"
	08165	Heater, 12 KW, 208/220 volt, 3 phase	29	03277	1/4" Ball Valve, manual drain
	08166	Heater, 12 KW, 230/240 volt, 3 phase	30	22221	Solenoid Valve, boiler drain
	08167	Heater, 12 KW, 440/480 volt, 3 phase	31	13252	Drain Manifold
	08163	Heater, 12 KW, 600 volt, 3 phase	32	45006	Low Water Cut-Off Assembly (California only)
	08214	Heater, 12 KW, 208/220 volt, 1 phase	33	41943	LWCO Mounting Plate (California only)
	08215	Heater, 12 KW, 230/240 volt, 1 phase	34	05253	Brass Street Elbow (California only)
			35	02523	Reducing Bushing, 1/2" - 1/4" (California only)
			36	19995	Float Switch, LWCO (California only)
				19993	DPDT Power switch
				19994	SPST Momentary contact reset switch
				07167	Pressure gauge, 0-30 psi, 1 1/2"

Manufacturer reserves right of design improvement or modification, as warranted.

SYMPTOM	CAUSE	REMEDY (See Text)
A timer does not count down when the compartment is hot.	<p>The thermostatic switch is not closing.</p> <p>Inoperative timer board.</p> <p>There is no 5.5 VAC signal to the timer board.</p> <p>Poor wiring connections from the thermal switch to the timer board.</p>	<p>Replace the thermostatic switch.</p> <p>Replace the timer board.</p> <p>Check the power supply board, cable assemblies, and connections. Repair or replace as necessary.</p> <p>Check the cable assemblies, wire harness, and connections. Repair or replace as necessary.</p>
Pressing a control panel switch pad for one compartment causes the controls of the other compartment to respond.	Damaged or inoperative control panel (membrane switch or ribbon connector).	Replace the control panel.
The timer display digits appear incomplete or the indicator LEDs do not light.	<p>Damaged or inoperative timer board</p> <p>The timer board is water-soaked.</p>	<p>Replace the timer board.</p> <p>Dry the timer board.</p>
The alarm sounds continuously (sound could be a low-pitched whistling).	<p>The power supply board is water soaked.</p> <p>The alarm is shorted.</p> <p>Damaged or short-circuited cable assembly.</p> <p>Damaged or inoperative timer board.</p>	<p>Dry the power supply board.</p> <p>Replace the power supply board.</p> <p>Check the cable assemblies and connections. Repair or replace as necessary.</p> <p>Replace the timer board.</p>
The flow of steam into a compartment will not shut off.	<p>The emergency by-pass switch is in the "on" position.</p> <p>Dirt or foreign material is jammed in the solenoid valve.</p> <p>Damaged or short-circuited timer board.</p>	<p>Turn off the switch</p> <p>Repair or replace the solenoid valve.</p> <p>Replace the timer board.</p>
The time entry will not hold in the display - one or both display digits change continuously.	Damaged or inoperative control panel (membrane switch or ribbon connector).	Replace the control panel.
When the "Start/Cancel" pad or "Manual Operation" pad is pressed the compartment steam solenoid valve opens, then closes immediately.	Insufficient supply voltage (120 VAC nominal) to the timer control box.	Check the building's supply voltage to the equipment, and check the wiring to the timer control box. Repair as necessary.

Cleveland Range, Inc.

UNITED STATES

1333 East 179th St., Cleveland, Ohio 44110
 Phone: (216) 481-4900 • Telex: 98-0546 • FAX: (216) 481-3782

CANADA

Garland Commercial Ranges
 1177 Kamato Road
 Mississauga, Ontario, Canada L4W1X4
 Phone: (416) 624-0260 • FAX: (416) 624-0623

TROUBLESHOOTING CHART FOR CLEVELAND CONVECTION STEAMER SOLID STATE COMPARTMENT CONTROLS

SYMPTOM	CAUSE	REMEDY (See Text)
Both timers do not operate. There are no lights or sounds	120 VAC power is not connected to the power supply board.	Check the wiring from the 120 VAC supply to the board (including the wire harness). Repair or replace as necessary.
	The 5 VDC circuit is short-circuited	Repair as required, or replace the shorted timer board, power supply board, or cable assembly.
	The 5 VDC power supply is inoperative	Replace the power supply board.
	Poor wiring connections from the power supply board to the timer boards.	Check the cable assemblies and connections. Repair or replace as necessary.
Both timers appear to operate, but steam does not flow into either compartment, and the alarm does not sound.	The 24 VDC circuit is short-circuited	Repair as required, or replace the shorted power supply board.
	The 24 VDC power supply is inoperative	Replace the power supply board
	Poor wiring connections from the timer boards to the power supply board.	Check the cable assemblies and connections. Repair or replace as necessary.
A compartment operates in only one mode, either timed or manual	Damaged or inoperative control panel (membrane switch)	Replace the control panel.
	Damaged or inoperative timer board.	Replace the timer board
One compartment will not operate in either mode, timed or manual, and the mode indicator LEDs do not light.	Damaged or inoperative control panel (membrane switch or ribbon connector).	Replace the control panel.
	Poor wiring connections from the power supply board to the timer board (of the affected compartment).	Check the cable assembly and connections (of the affected compartment). Repair or replace as necessary.
	Damaged or inoperative timer board	Replace the timer board.
A timer appears to operate, but steam does not flow into the compartment.	Poor wiring connections from the power supply board to the solenoid valve.	Check the wire harness and connections. Repair or replace as necessary.
	Damaged or inoperative relay on the power supply board.	Replace the power supply board.
	Damaged or inoperative solenoid valve.	Repair or replace the solenoid valve.
	Damaged or inoperative emergency by-pass switch.	Replace the switch.
	Damaged or inoperative timer board.	Replace the timer board.

FIGURE 4 POWER SUPPLY BOARD SIMPLIFIED SCHEMATIC

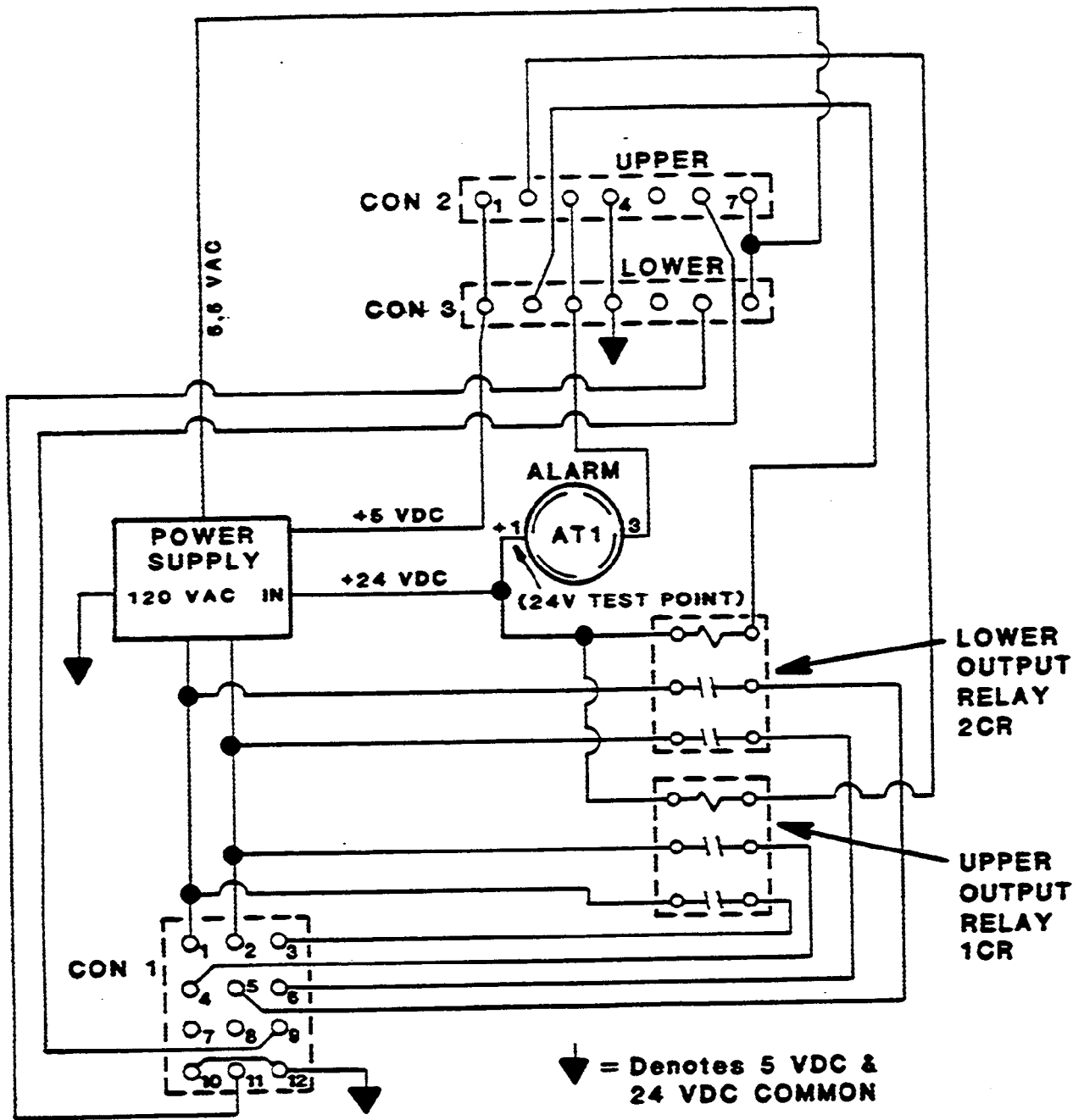

PIN NO.	CON 2, & CON 3
1	+5VDC SUPPLY
2	RELAY OUT
3	ALARM OUT
4	5 AND 24 VDC COMMON
5	POLARIZED KEY
6	THERMOSWITCH
7	5.5 VAC

PIN NO.	CON 1
1	120VAC
2	120VAC
3	UPPER COMPARTMENT
4	UPPER COMPARTMENT
5	LOWER COMPARTMENT
6	LOWER COMPARTMENT
7	NO CONNECTION
8	NO CONNECTION
9	UPPER THERMOSWITCH
10	UPPER THERMOSWITCH
11	LOWER THERMOSWITCH
12	LOWER THERMOSWITCH

FIGURE 3 COMPARTMENT CONTROL PANEL (MEMBRANE SWITCH)

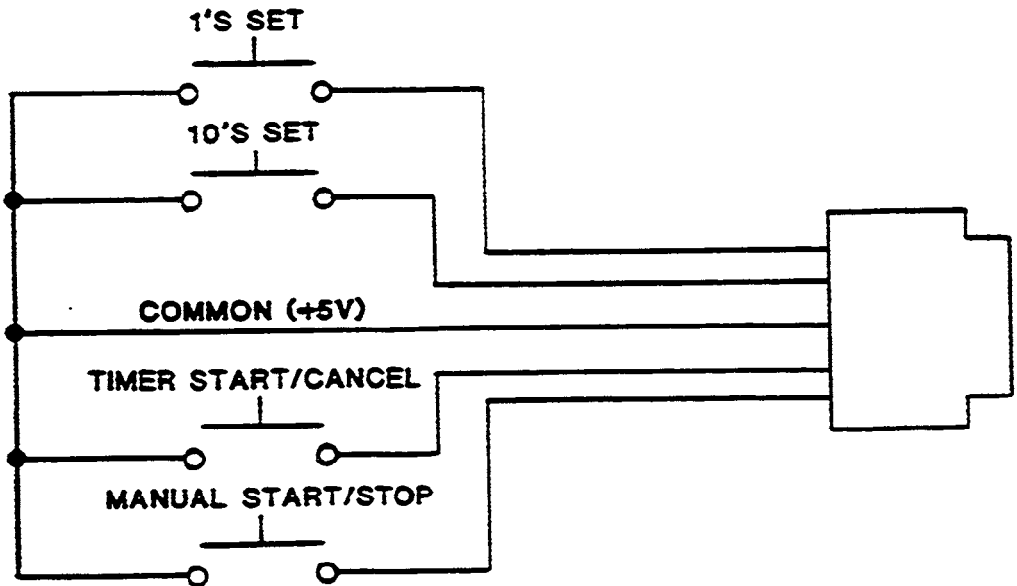
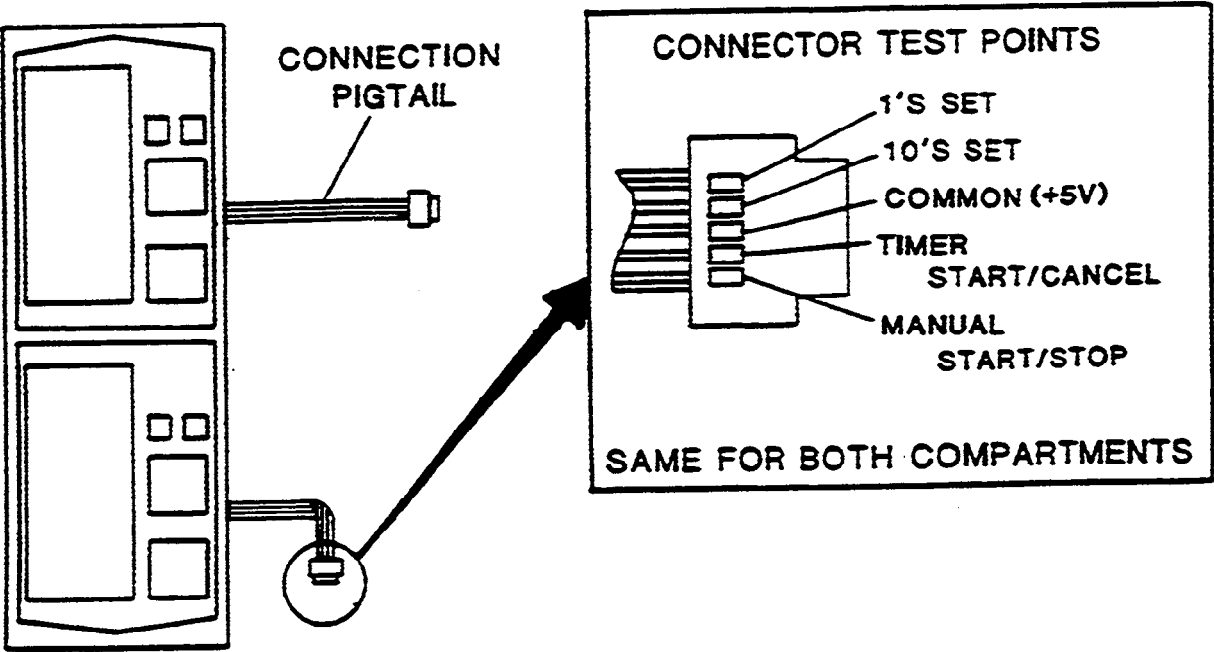

SAME FOR BOTH COMPARTMENTS

short circuit is in a timer board or a cable connector. If the LED illuminates when the cable connectors are disconnected, a timer board or cable connector is shorted. NOTE: The power supply regulators are thermally protected and may overheat. In this case, the regulators require time to reset to their "on" condition before they allow the LEDs to illuminate.) Reconnecting the cable connectors one at a time will indicate which timer board (or cable) is shorted, as the LED will not be lit when the defective board's cable is reconnected. To determine if the short circuit is in a cable connector, disconnect each cable from the timer boards, then connect each cable, one at a time, to the power supply board. The LED will not be lit when the defective cable is reconnected. The actual output voltages may be measured between "Common" and the cable connector pins, as shown in figure #4. (pin #1 = 5 VDC, pin #7 = 5.5 VAC, alarm's solder joint labelled "+1" = 24 VDC).

The output relays are used to switch 120 volts AC on and off to the steam and water solenoid valves of the compartments. The relay coils (24 VDC) need only a "common" connection to operate. In normal operation the "common" path is provided by the timer boards (20479). To test the relays, shut off the power to the steamer at the main on/off switch. Disconnect the wiring cable assemblies (03002 and 03003) from the power supply board, and remove the control panel. Connect a jumper from pin #2 to pin #4 of each cable connector (on the power supply board). Restore power to the steamer. The relays should close upon application of power.

A similar test can be used to test the alarm. Jumping pin #3 to pin #4 of either cable connector will cause the alarm to sound.

FIGURE 1 COMPARTMENT CONTROL BOX COMPONENTS

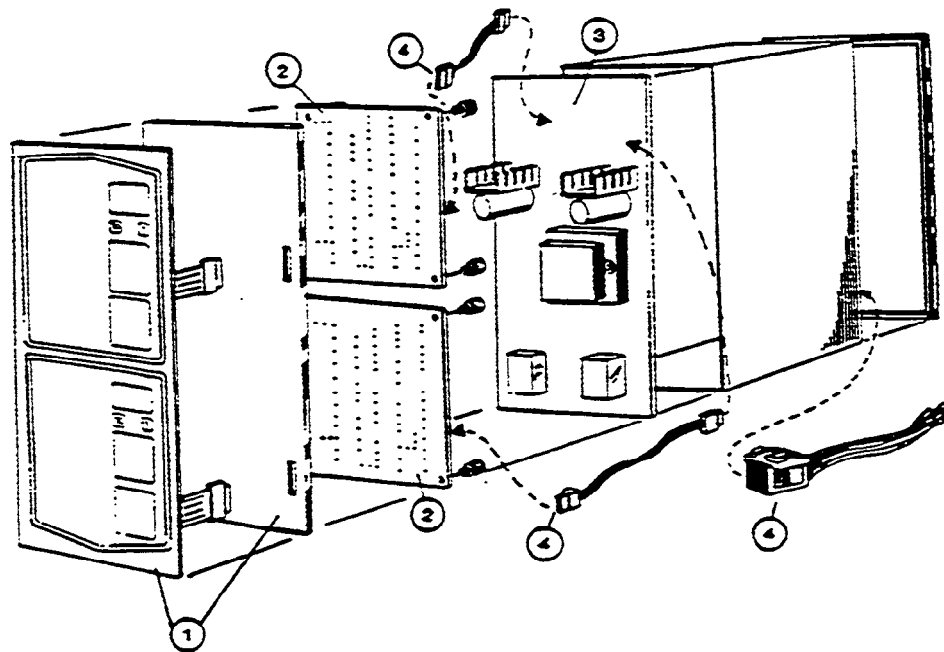

REFERENCE NUMBER	PART NUMBER	DESCRIPTION
1	45005	Control Panel (Membrane Switch)
2	20479	Solid State Timer
3	16652	Power Supply Board
4	03002	9" Cable Assembly
4	03003	14" Cable Assembly
4	08135	Wire Harness

pressed. Check to be sure that no other pins show continuity to "common" except the pin of the switch being pressed.

CAUTION; When checking continuity, it is best to use a VOM or multimeter, as higher lamp currents of some continuity testers may damage the switch contacts. Resistance reading should be less than 50 ohms. DO NOT use AC line voltage or DC voltages above 5 VDC.

Check for damaged or abraded ribbon connectors that may cause shorting to the metal of the control enclosure. If necessary, insulate the ribbon by placing black electrician's tape along the tracer side of the ribbon connector.

SOLID STATE TIMER BOARD

Complete testing of the timer board in the kitchen may be impractical. However, knowing the functions which are exclusive to the timer board, accurate diagnosis of failures can be made.

The following functions are performed by each timer board:

1. Cooking time entry and storage.
2. Display of cooking time remaining.
3. Count down (timing) when the compartment thermostatic switch is closed.
4. Energizing the output relay during cooking cycles (manual and timed).
5. Manual on/off control of the compartment.
6. Sounding the alarm for four seconds at the end of the cooking cycle.
7. Display of operating mode (manual and/or timed).
8. Flashing display digits after the end of the timed cooking cycle.

Although the other components in the control system are necessary for proper operation, they are only support or interface hardware for these timer boards.

All logic and operating sequences are the direct functions of the timer boards.

Generally, failures that affect the operation of both compartments are not associated with the timer boards, as each timer board independently controls a single compartment. When there is trouble with the operation of one compartment control only, simple tests made by switching wire cables at the power supply board, or swapping timer boards, are helpful in pinpointing a defective unit. As an example, if a serviceman found that the upper compartment's controls did not switch on the solenoid valves for that compartment, he may proceed as follows. First, with the steamer power off, the interconnecting cables (03002 and 03003) could be interchanged at the power supply board. With the steamer's power restored, if the same compartment failed to operate, this would indicate a problem with the power supply board, wire harness (08135), or solenoid valves. If the symptoms changed from the upper compartment to the lower, then the fault is in the timer board or control panel. The control panel may be tested individually as described in the "Control Panel" Section, or it can be tested by swapping the timer boards. To do this, interchange the upper and lower timer boards and connect the wire cables in their original, correct order. If, after changing the boards (and installing cables correctly), the upper compartment still does not work, then the control panel is at fault. On the other hand, if the symptoms changed from the upper compartment to the lower, then the fault is in the timer board now mounted on the bottom. Due to the simple wiring and mounting design of the solid state controls, these types of tests can often be done faster than testing with meters or special test set-ups.

POWER SUPPLY BOARD

The basic function of the power supply board is as an interface between the 120 VAC control system of the steamer and the low voltage (5 VDC) circuits of the timers. All connections to the board are provided by polarized multi-pin cable or harness connectors.

A simplified schematic of the board is shown in figure #4.

The power supply, including transformer, is powered by 120 volts AC, and provides 3 output voltages:

1. 5 volts DC to power the solid state timers and digital displays.
2. 24 volts DC to power output relay coils and the alarms.
3. 5.5 volts AC to provide clock pulses to the timers.

The 5 volt and 24 volt DC outputs of the power supply are equipped with LED indicators to aid in troubleshooting. In normal operation, these LED's should be illuminated any time power (120 VAC) is supplied to the board. If there is no output voltage from the 5 volt DC and/or 24 volt DC supplies, then the corresponding LED will not be lit. In addition, both the 5 volt and the 24 volt DC supplies are protected against short circuits. If there is a short circuit, the voltage regulator of the affected supply will shut down and the indicating LED for that supply will not be lit. This feature can be useful in determining the location of a short circuit. Disconnect the cable connectors at the power supply board to determine if the

SERVICE GUIDE FOR CLEVELAND CONVECTION STEAMER SOLID STATE COMPARTMENT CONTROLS

Read the following instructions to familiarize yourself with the solid state timer components and their functions. Once familiar with the operation, refer to the troubleshooting guide when on the job site (to diagnose the problem), then refer back to the instructions for specific tests.

The solid state compartment control system for Cleveland Range Steamers is designed for easy service. No special tools or technical training is required to troubleshoot and repair these controls. A suggested list of required tools is as follows:

1. Screwdriver (blade type)
2. 1/4" or 5/16" nut driver
3. V.O.M. or multimeter

Refer to Figures #1 and #2. The system contains 4 basic components: (1) control panel (45005), (2) two solid state timers (20479); (3) power supply board (16652); (4) interconnecting cables and harness (03002, 03003, 08135). Each of these four parts will be discussed in detail. Solenoids and manual bypass switches will not be covered in this guide. All of these parts, except #08135, are assembled in one enclosure (40833) that can be removed easily from the front of the steamer.

The Convection Steamer cooking compartments are controlled by a low voltage solid state system that provides both timed and manual operation of the cooking compartments.

All wiring connections to the timer system are provided through a multipin connector that is part of the power supply board. The wiring harness is equipped with the mating part for the connector.

The power supply board provides 24 VDC to power the output relay coils and the alarm, 5 VDC for the timer and logic power, and 5.5 VAC to provide clock pulses to the timers. The stepdown transformer is mounted to the power supply board. Also on this board are two DPDT relays (one for each compartment) which are used to switch 120 VAC on and off to the compartment steam and water solenoid valves. A 4 second piezo type alarm mounted on the power supply board is used to signal the steamer operator at the end of the cooking cycle.

Each solid state timer is wired to the power supply board by a cable assembly and to the control panel by a ribbon connector. These timer boards are equipped with LED displays to indicate cooking time and operating mode. Compartment thermostatic switches are wired to the timers through the power supply board and cable assemblies, and operate at 5 VDC. These thermostatic switches (normally open, then close at 193° F) are used to activate the timers when the compartments reach cooking temperature. Each timer board and thermostatic switch independently controls a single compartment.

The control panel contains the membrane type switches which provide 5 VDC command signals to the timer boards. The metal backing plate is used to mount the two timer boards.

Two DPDT emergency bypass switches (one for each compartment) are provided, with the switch "commons" connected to the load. Both switches should normally remain in the "run" position. With a switch in the "run" position, the appropriate steam and water solenoid valves will be operated by the control system described above. In the event of a failure in the solid state compartment control system, the system can be bypassed by placing one or both switches in the "bypass" position. With a switch in the bypass position, the appropriate steam and water solenoid valves will be energized continuously. Each switch can be used to manually operate a cooking compartment until the control system is repaired.

CONTROL PANEL (MEMBRANE SWITCH)

The control panel (45005) consists of a membrane switch panel bonded to a stainless steel backing plate. This metal plate is also used to mount the two solid state timer boards (20479). All control panel switches are normally open, momentary contact, pressure sensitive membrane type switches. All control panel switches operate at 5 VDC. Each switch is used to provide a command signal to the timer boards.

The switch circuitry for each compartment is separate from the other compartment. Two separate connectors (one for each compartment) are used to connect the switches to the timer boards. This separation allows one compartment to work even if control switches of the other compartment are damaged. If pressing a control switch of one compartment causes the control of the other compartment to respond, the control panel (membrane switch) is defective or damaged.

The switch panel can be tested individually by continuity testing. Refer to figure #3. With none of the switches being pressed, there should be no continuity between any two pins of the connector. When checking an individual switch, there should be continuity between the common pin and the designated pin of the switch only when the switch is

CONVECTION STEAMER PIPING COMPONENTS

(Solid State Model "C" with Touch Control Timer Panel)

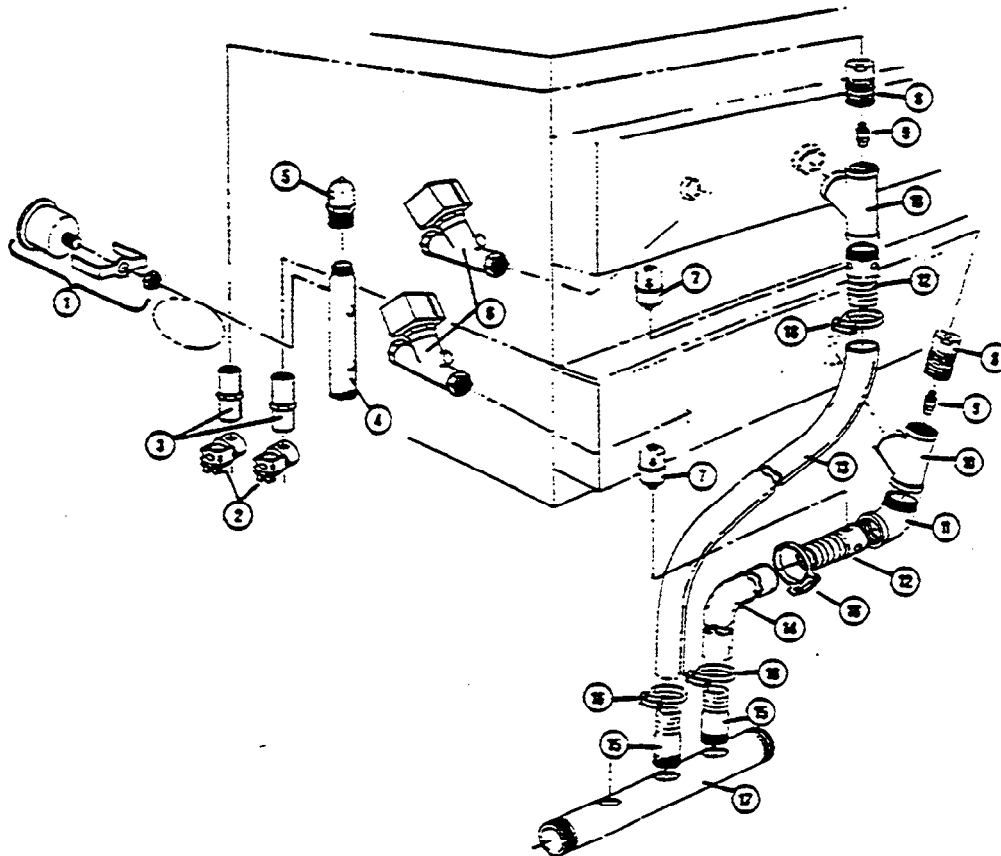

REFERENCE NUMBER	PART NUMBER	DESCRIPTION
1	07168	Pressure Gauge
2	22218	Water Solenoid Valve
3	15455	Flow Regulator, ½ GPM
4	13301	Steam Manifold
5	22226	Air Vent
6	22224	Steam Solenoid Valve
7	20559	Thermostatic Trap
8	06230	Reducing Bushing for Nozzle
9	14555	Nozzle, Jet, Steam Condenser
10	02139	1" T
11	05227	1" Street Elbow
12	56519	Compartment Drain Fitting (2 holes)
13	70743	Tubing, 39" long
14	70742	Tubing, 28" long
15	14481	Combination Hose Fitting (no holes)
16	03180	Hose Clamp
17	13252	Drain Manifold

CLEVELAND RANGE, INC., 1333 EAST 179th ST., CLEVELAND, OHIO 44110

Manufacturer reserves right of design improvement or modification, as warranted.

CONVECTION STEAMER ELECTRICAL COMPONENTS

(Solid State Model "C" with Touch Control Timer Panel)

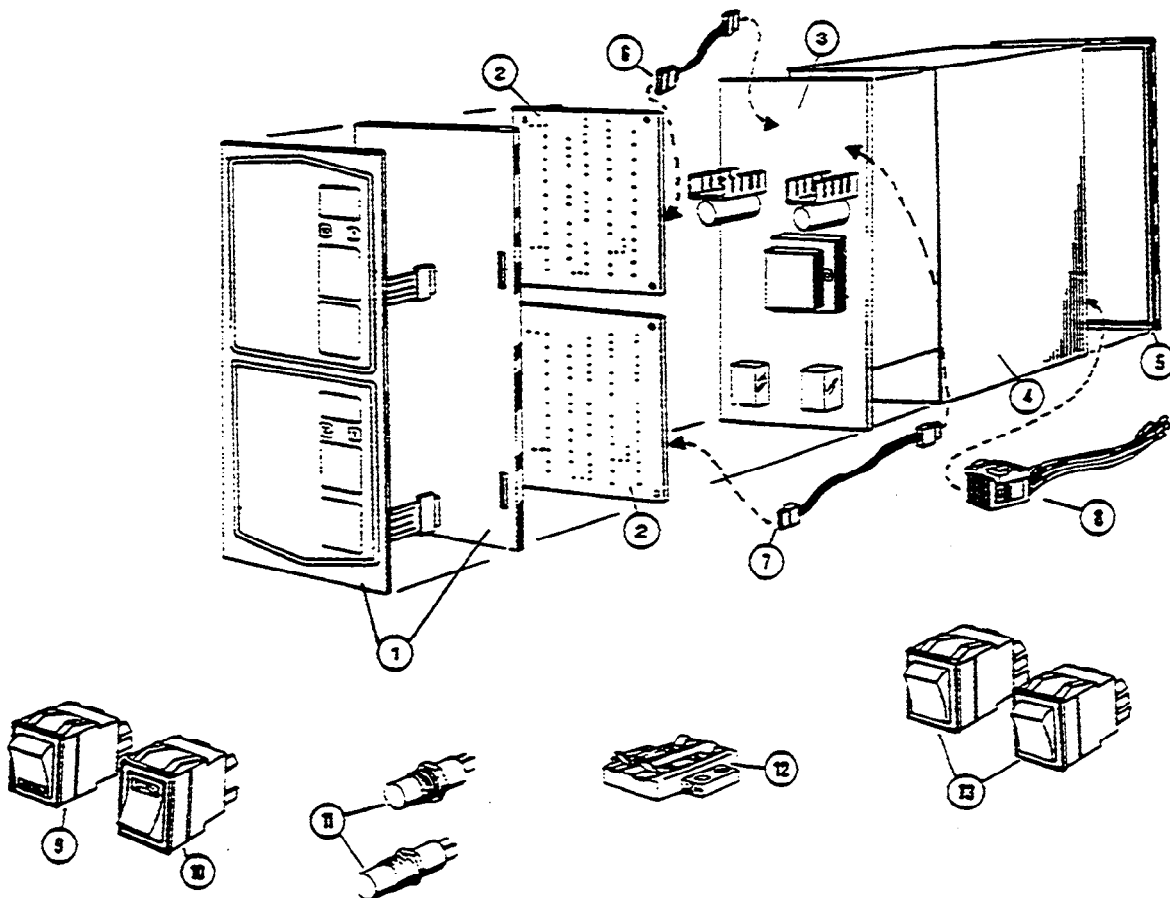

REFERENCE NUMBER	PART NUMBER	DESCRIPTION
1	45005	Control Panel (Membrane Switch)
2	20479	Solid State Timer
3	16652	Power Supply Board
4	52595	Instrument Panel Enclosure
5	56228	Instrument Panel Frame
6	03002	9" Cable Assembly
7	03003	14" Cable Assembly
8	08135	Wire Harness
9	19993	DPDT Power Switch
10	19994	SPST Momentary Contact Reset Switch
11	19972	Thermostatic Switch
12	44168	Terminal Block, 2 pole
13	19992	DPDT Rocker Switch, Emergency Bypass

CLEVELAND RANGE, INC., 1333 EAST 179th ST., CLEVELAND, OHIO 44110
 Manufacturer reserves right of design improvement or modification, as warranted.

