

Cleveland Range

EconoCraft[®]

Counter Type

Convection Steamer

SERVICE MANUAL

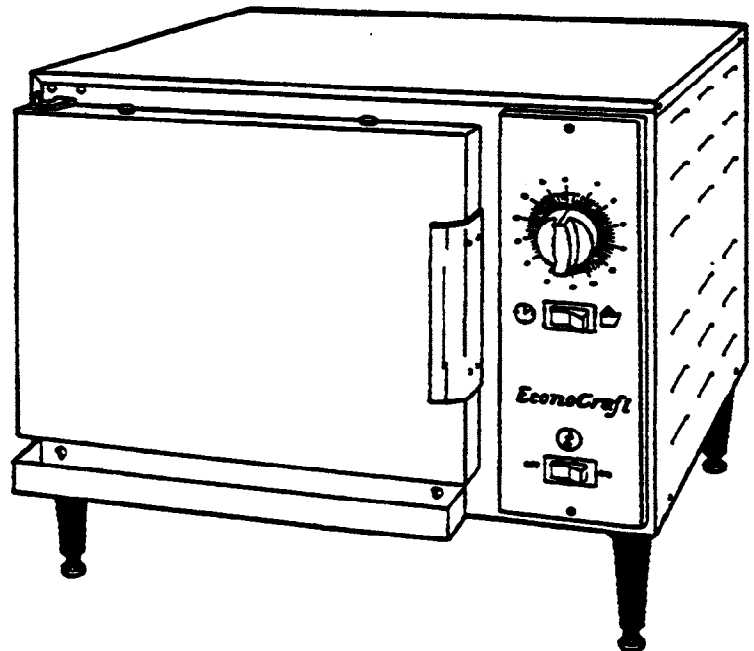

Printed 5/93

MODEL 24-CET-1

Cleveland Range, Inc.

UNITED STATES

1333 East 179th St. Cleveland, Ohio 44110
Phone: (216) 481-4900 Telex: 98-0546
FAX: (216) 481-3782

CANADA

Garland Commercial Ranges
1177 Kamato Road
Mississauga, Ontario, Canada L4W1X4
Phone: (416) 624-0260 FAX: (416) 624-0623

CTS-06

PROTECTING WARRANTY COVERAGE

The warranty printed to the left specifies the owner/user's responsibility for proper installation, operation, and maintenance of the EconoCraft. If these responsibilities are not met, the Limited Warranty and/or Extended Limited Warranty coverage may be adversely affected. The following table is provided to assist the owner/user in meeting these responsibilities. In addition, the warranty advantages of installing a SteamerGard water treatment system are explained after the table.

The Warranty Protection Table lists installation, operation, and maintenance factors that have in the past adversely affected warranty coverage. The owner/user of an EconoCraft should pay particular attention to these factors to protect his warranty coverage. This table is not a comprehensive list of the owner/user's responsibilities. Cleveland Range steam products are intended for use only by professionally trained personnel. To meet his responsibilities, the owner/user must supplement this guide with any additional actions consistent with the operation of steam generating food preparation equipment by a trained professional.

Warranty Protection Table

SUBJECT	PAGE REFERENCE
Electric Power Requirements	7
Water Quality Requirements and Analysis	7
Steam Generator Maintenance and Maintenance Records	31
Daily Draining and Washout	31
Descaling Frequency and Procedure	32
Approved Chemical Cleaners	32-33
Authorized Maintenance and Repair	35
Unvented Drain	11
Blocked Drain	33
Water Pressure	16

SteamerGard Water Treatment System

A SteamerGard water treatment system protects the EconoCraft from impurities contained in regular tap water, especially Total Dissolved Solids (TDS) which cause lime and scale deposits in steamer equipment. The protection is so effective that Cleveland Range increases the warranty coverage on an EconoCraft installed in conjunction with a SteamerGard system to five years for parts and three years for labor on water related components, elements, valves, generators, piping, etc. However, even with a SteamerGard system installed, the owner/user should follow the guidance of the Warranty Protection Table.

Table of Contents

Chapter	Page
CHAPTER 1. PRODUCT IDENTIFICATION	1
MODEL NUMBER	1
SERIAL NUMBER	1
PRODUCT INFORMATION PLATE	1
 CHAPTER 2. INSTALLATION INSTRUCTIONS	 3
INTRODUCTION	3
INSTALLATION POLICIES	3
INSTALLATION OVERVIEW	4
PREPARATION FOR INSTALLATION	5
Unpacking and Inspection	5
Shipping Damage Instructions	6
Electric Power Requirements	7
Water Quality Requirements	7
Softened, Treated, or Filtered Water	8
Select the Operating Location	8
INSTALLATION INSTRUCTIONS	10
Assembly	10
Install Four Legs	11
Position and Level EconoCraft	11
Install and Connect the Free Air Vented Drain Lines	11
Install Electric Power Lines	13
Connect Electrical Line	14
Canadian Wiring Considerations	15
Install Water Supply Lines	15
Connect Water Supply Lines	17
Single Untreated Water Connection	17
Double Water Connection With Preheater	17
Double Water Connection With SteamerGard	18
Testing Water Supply Lines	18
Final Setup And Checkout	19
Setup	19
MANUAL Test	19
TIMED Test	20
Condenser Flow Adjustment	21
 CHAPTER 3. OPERATION	 23
INTRODUCTION	23
OPERATIONAL SAFETY	23
CONTROL PANEL	24
DRAIN PLUG	24
MANUAL MODE	25

Table of Contents *(continued)*

Chapter	Page
TIMED MODE	25
STARTUP AND PREHEAT	26
COOKING	26
TIMED Cooking	27
MANUAL Cooking	27
DRAIN STEAM GENERATOR (Every 4 hours)	28
SHUT DOWN (At end of day or shift)	28
CHAPTER 4. PREVENTATIVE MAINTENANCE AND TROUBLESHOOTING	31
INTRODUCTION	31
MAINTENANCE RECORDS	31
DAILY MAINTENANCE	31
Clean EconoCraft	31
WEEKLY MAINTENANCE	31
Descale Steam Generator	32
YEARLY MAINTENANCE	33
TROUBLESHOOTING GUIDE	34
TROUBLESHOOTING NOTES	35
TROUBLESHOOTING QUICK TEST	36
CHAPTER 5. ELECTRICAL SYSTEM	37
INTRODUCTION	37
Figures And Illustrations	37
ECONOCRAFT ELECTRICAL CIRCUITS	37
High Voltage Circuit	37
120 VAC Circuit	37
Low Voltage Control Circuit	39
Timer Circuits	39
CIRCUIT OPERATION	39
MANUAL Mode Circuit Operation	39
TIMED Mode Circuit Operation	40
ELECTRICAL CIRCUIT COMPONENTS	41
Terminal Block	41
Heater Element	41
ON/OFF Switch	42
TIMED/MANUAL Switch	42
Fill Solenoid Valve	42
Condenser Solenoid Valve	43
Mechanical Timer	43
3-Second Timer and Buzzer	44
High Temperature Limit Switch	44

Table of Contents (continued)

Chapter	Page
Water Level Control Unit.....	44
Water Level Probe Assembly.....	45
Low Level Probe.....	45
High Level Probe.....	45
COMPONENT TESTING GUIDE INTRODUCTION.....	46
Nominal Voltage.....	46
FUNDAMENTAL COMPONENT TESTING.....	46
Visual Check.....	47
Connection Points and Wiring.....	47
Solenoid Valves.....	47
Timers.....	48
Thermostatic Snap Switches.....	48
Terminal Block.....	48
Heater Element.....	49
Resistance Measurements.....	49
Insulation Resistance Measurements.....	49
Voltage Measurements.....	50
COMPONENT TEST PROCEDURES.....	50
Initial conditions for all testing.....	50
CT:1 ON/OFF Switch.....	50
CT:2 Fill Solenoid Valve.....	51
CT:3 Condenser Solenoid Valve.....	52
CT:4 TIMED/MANUAL Switch.....	53
CT:5 High Temperature Limit Switch.....	54
CT:6 Mechanical Dial Timer.....	55
CT:7 Heater Contactor.....	55
CT:8 Heater Elements.....	56
CT:9 Water Level Control Unit.....	58
CT:10 3-Second Timer and Buzzer.....	59
CT:11 Low Level Probe.....	60
CT:12 High Level Probe.....	60
CT:13 Transformer.....	61
CHAPTER 6. ILLUSTRATED PARTS LISTS.....	63
INTRODUCTION.....	63
Parts Differences Among Econocraft Steamers.....	63
Electrical Wiring and Schematic Ladder Diagrams.....	63
Ordering Parts.....	63

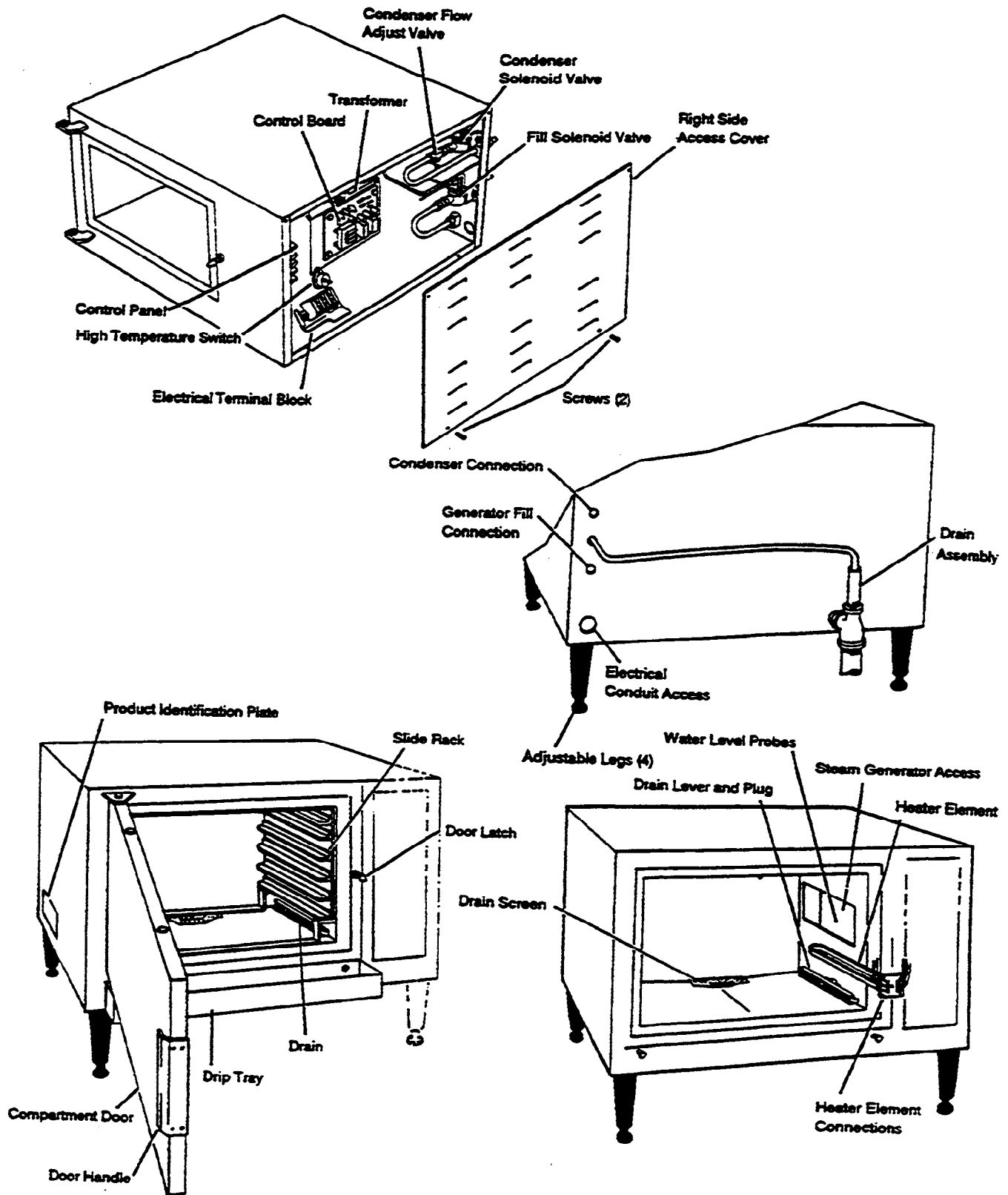

Figure 1-1 EconoCraft Counter Type Convection Steamer

CHAPTER 1. PRODUCT IDENTIFICATION

Cleveland Range, Inc. identifies products by two numbers: a model number and a serial number. The model number identifies the product characteristics. The serial number identifies the individual unit.

MODEL NUMBER

EconoCraft steamers are identified by model number 24-CET-1. Each character of the model number identifies a characteristic of the steamer. The EconoCraft is a Convection steamer, Electric powered, and Table-mounted with an input energy rating of 8 kW. This manual covers all standard features of model 24-CET-1 EconoCraft steamers. Figure 1-1 illustrates the EconoCraft and identifies the major components.

SERIAL NUMBER

During manufacture, EconoCrafts are assigned serial numbers. A typical EconoCraft serial number is WC-7350-90G-02. The left half of the number carries design information. The right half of the number contains the manufacturing date and the unit of the manufacturing lot. The date of our sample number is 90G-02: 90=1990, G=July. 02=the second unit of the manufacturing lot. Serial numbers are used when explaining differences in design, parts, or operation among units with the same model number. For example: a particular part may be used on all 24-CET-1 steamers with serial numbers before WC-7350-90G-02, and a different part used on 24-CET-1 steamer WC-7350-90G-02 and all those manufactured after it.

Presently, there are no significant design, parts, or operating differences among model 24-CET-1 EconoCraft steamers.

PRODUCT INFORMATION PLATE

The Product Information Plate on the left side of the unit lists the model number and serial number for the steamer. Refer to Figure 1-1 for the location of the plate. Figure 1-2 illustrates a typical EconoCraft product information plate. The plate also lists power and wiring requirements.

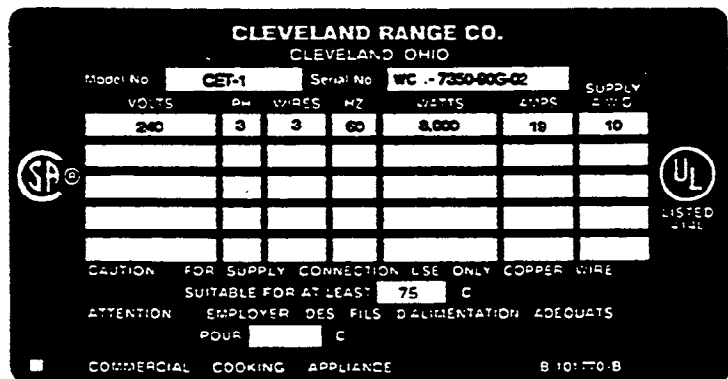

Figure 1-2. EconoCraft Product Information Plate

WARNING

DEATH, INJURY, AND EQUIPMENT DAMAGE could result from improper installation of the EconoCraft, or from installation of a unit damaged during shipment or storage. Either of these conditions could also void the equipment warranty.

DO NOT INSTALL an EconoCraft suspected of damage.

Install the EconoCraft according to the policies and procedures outlined in this manual.

CHAPTER 2. INSTALLATION INSTRUCTIONS

INTRODUCTION

This chapter is a guide for qualified, professional plumbers and electricians installing the EconoCraft steamer. This guide does not include procedures and precautions in the common domain of licensed plumbers and electricians, or experienced food service equipment installers. The instructions in this chapter must be used in conjunction with a thorough understanding of the Basic Plumbing Code of the Building Officials and Code Administrators International, Inc. (BOCA) and the Food Service Sanitation Manual of the Food and Drug Administration (FDA).

Before starting installation, the owner and the installer should read through this chapter and thoroughly understand and agree upon:

- The installation policies of Cleveland Range, Inc. as stated in Installation Policies.
- An installation plan based on Installation Overview and Preparation For Installation.
- Responsibility for feed water quality and its testing as described in Preparation For Installation, Water Quality.

INSTALLATION POLICIES

- The EconoCraft must be installed by qualified plumbing and electrical personnel, working to all applicable national and local codes. Equipment installation must comply with the Basic Plumbing Code of the Building Officials and Code Administrators International, Inc. (BOCA) and the Food Service Sanitation Manual of the Food and Drug Administration (FDA).
- Cleveland Range designs and manufactures equipment to comply with applicable standards for manufacturers. Included among those certification agencies which have approved the safety of the equipment design and construction are: UL, A.G.A., ASME/N.Bd., NSF, CSA, CGA, ETL, and others.
- This equipment is designed and certified for safe operation only when permanently installed in accordance with local and/or national codes. Many local codes exist, and it is the responsibility of the owner and installer to comply with these codes.
- In no event shall the manufacturer assume any liability for damage or injury resulting from installations which are not in strict compliance with the Installation Instructions and the codes cited above. Specifically, the manufacturer will not assume any liability for damage or injury resulting from improper installation of equipment, including, but not limited to, temporary or mobile installations.

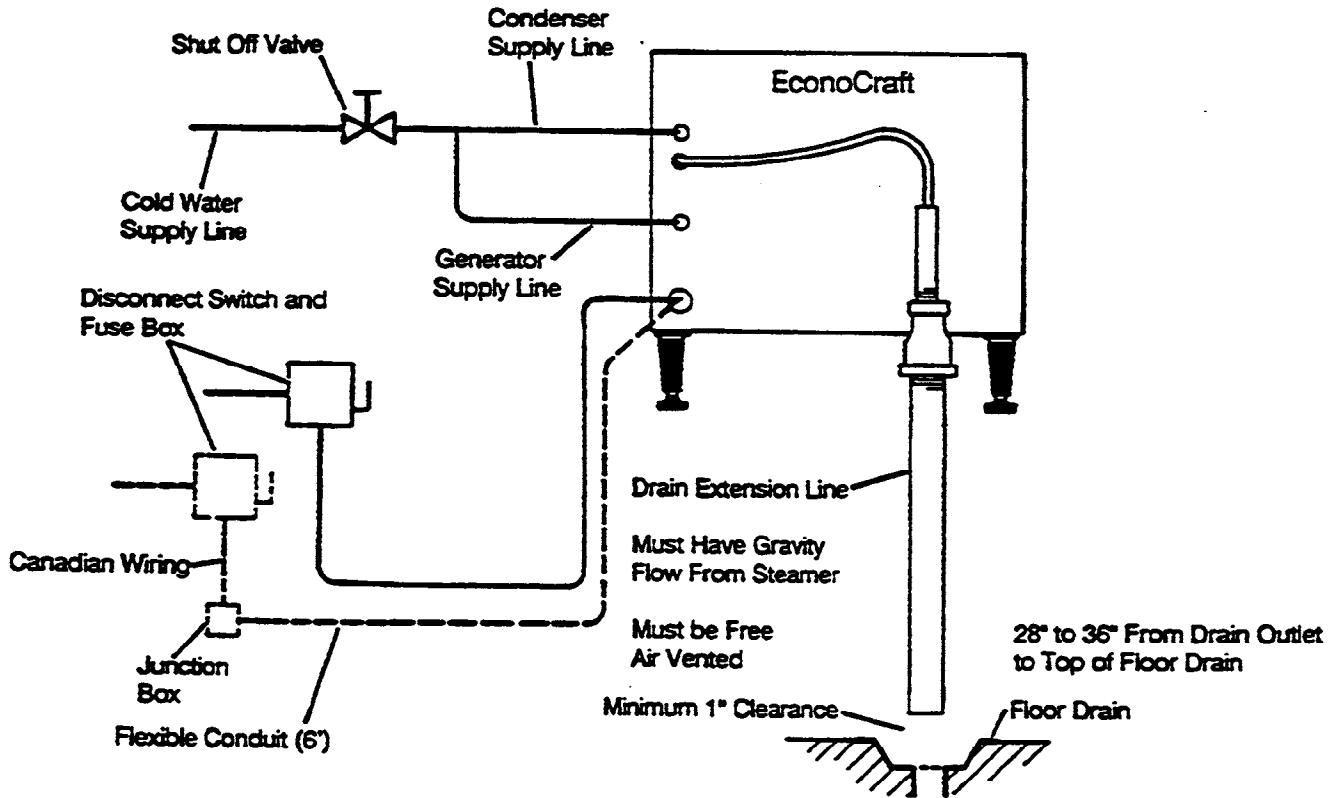

Figure 2-1. Schematic Installation Diagram

INSTALLATION OVERVIEW

Schematic Installation Diagram, Figure 2-1, illustrates the various electrical, water, and drain lines that must be connected to the EconoCraft. These lines can be constructed and connected to the EconoCraft easily and without delays, if the various construction and installation tasks are performed in a planned sequence. Table 2-1 summarizes these tasks and lists them in a recommended sequence. The Installation Check List outlines the overall installation process; the instructions referenced in Table 2-1 provide details. Installation requirements may vary from site to site; adapt the check list accordingly.

Table 2-1. Installation Check List

TASK	PAGE REFERENCE	COMPLETED
Preparation		
Test EconoCraft water supply.	6	_____
Select water supply system.	6	_____
Install water treatment system.	6	_____
Select EconoCraft location.	8	_____
Installation		
Unpack and inspect EconoCraft.	5	_____
Assemble parts shipped loose.	6	_____
Position and level EconoCraft.	11	_____
Install drain line.	11	_____
Connect drain line.	11	_____
Install electric power line.	13	_____
Connect electrical line.	14	_____
Install water supply lines.	15	_____
Connect water lines.	17	_____
Perform final setup and checkout.	19	_____

PREPARATION FOR INSTALLATION

Select and prepare the EconoCraft operating location before permanently positioning the unit. Protect the unit and packaged components during site preparation. Do not select the operating location or start installation before checking the electric power, gas, and water quality requirements to assure proper drainage, ventilation, and safety.

Unpacking and Inspection

1. Before unpacking the shipping carton, visually inspect it for damage.
 - If the shipping carton appears damaged, do not open the carton. Refer to the Shipping Damage Instructions below.
 - If the shipping carton is undamaged, open it and remove the EconoCraft.
2. Slit the four corners of the carton and peel carton sides away from the EconoCraft.
3. Open the door of the EconoCraft, and remove the package of parts. The package contains six parts as illustrated in Figure 2-2. Check that all parts have been included in the package.

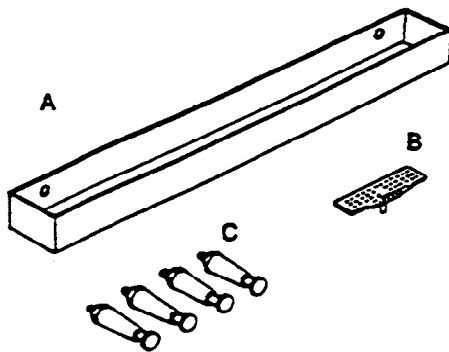

- A Drip Tray
- B Drain Screen
- C 4 Legs

Figure 2-2. Parts Package Components

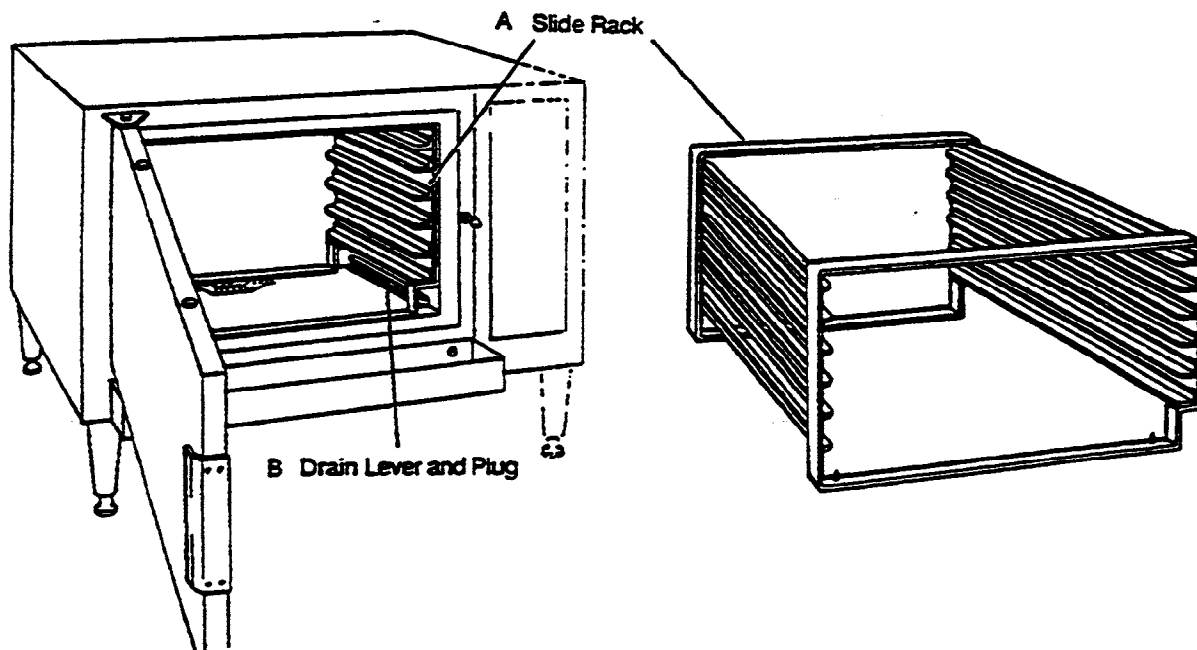

Figure 2-3. Pre-assembled Parts

4. When the parts package is removed, several pre-assembled parts can be seen inside the unit. Refer to Figure 2-3. Do not remove or try to operate these parts at this time.

- A Pan Rack
B Drain Plug and Lever

5. Inspect the EconoCraft and parts for damage or loss.
- If you discover or suspect shipping damage or loss, refer to the Shipping Damage Instructions below.
 - If all items are accounted for and undamaged, proceed to Assembly and install the unassembled parts listed in step 3.

Shipping Damage Instructions

If shipping damage to the EconoCraft is discovered or suspected, observe the following guidelines in preparing a shipping damage claim.

- Write down a description of the damage or the reason for suspecting damage as soon as it is discovered. This will help in filling out the claim forms later.
- As soon as damage is discovered or suspected, notify the carrier that delivered the shipment.
- Arrange for carrier representative to examine damage.
- Fill out all appropriate claim forms and have the examining carrier sign and date each form.

Electric Power Requirements

The characteristics of the electric power supply must match the power requirements specified on the EconoCraft Product Information Plate. The plate is located on the left side of the unit.

Water Quality Requirements

As with any steam generating equipment, poor water quality degrades EconoCraft performance. If feed water is low in Total Dissolved Solids (TDS) and free of particulate matter, the steam generator, heating element, and valves of the EconoCraft will give years of trouble-free service with a minimum of maintenance.

In some areas, even potable tap water contains a variety of impurities that can cause costly problems in steam generating equipment. Of primary concern are mineral salts and other impurities which remain behind as lime or scale deposits during the steam generating process. These deposits have caused many components to fail, including heating elements, probes, and solenoid valves. Of equal importance, lime and scale deposits decrease the efficiency of heat transfer which causes increased water and power consumption. EconoCraft use in areas with poor water quality requires installation of a SteamerGard water treatment system or increased frequency of maintenance, cleaning, and descaling.

Check the quality of feed water before starting construction of the water supply lines. If a SteamerGard water treatment system must be installed to achieve acceptable water quality, install it before running the water supply lines to the EconoCraft.

Contact a local water treatment specialist for an on-the-premises water analysis. The recommended minimum feed water quality requirements for the EconoCraft are listed in Table 2-2.

- If analysis shows that the supply water is within the required limits, a single water connection can be installed as illustrated in Figure 2-13.
- If analysis shows the supply water within required limits and a hot water heater is desired for preheating water to the steamer, install as illustrated in Figure 2-14. **DO NOT** install with hot water to the condenser inlet. The condenser supply must be cold water for proper operation of the steamer.
- If analysis shows that the supply water is **NOT** within the required limits, a SteamerGard water treatment system and two water supply lines must be installed as illustrated in Figure 2-15.
- If analysis shows that the supply water is **NOT** within the required limits, and it is not possible to install a SteamerGard water treatment; plan on increasing the frequency of maintenance, cleaning, and descaling beyond that recommended in the maintenance schedule (Chapter 4, page 31).
- Always connect a cold water supply to the EconoCraft water supply lines. **DO NOT USE HOT WATER.** The steamer will not function properly or within design safety limits if hot or warm water is supplied to either the condenser connection or the steam generator fill connection.

Table 2-2. Minimum Feed Water Quality Requirements

Total Dissolved Solids	less than 60 parts per million
Silica	less than 13 parts per million
Alkalinity	less than 20 parts per million
ph factor	greater than 7.5

Softened, Treated, or Filtered Water

Do not use softened or chlorinated water in the EconoCraft steam generator. If the water supply is treated or softened either by the water company or on the premises, it may contain chlorine or various salts. These additives are damaging to the EconoCraft steam generator. Salts used to soften water cause rapid scale buildup, and increased corrosion.

Some water treatment plants kill bacteria in the water by adding chlorine. Chlorinated water is actually dilute hydrochloric acid. It is very damaging to the EconoCraft. When heated in the steam generator, chlorinated water rapidly dissolves generator walls and heater elements. In extreme cases, poisonous and highly corrosive chlorine gas is released in the steam generator.

Installing a high volume, charcoal or reverse osmosis, water filtering system removes most of the salts and chlorides introduced by water treatment and softening. Contact a local water treatment specialist or the local water company for assistance with chlorinated water.

Select the Operating Location

When selecting an operating location for the EconoCraft, observe the following criteria.

- The EconoCraft uses a minimum of counter space. Figure 2-5 illustrates the dimensions and clearances required. The 3-inch clearance at the rear includes spacing for the water inlet and fittings, and the maximum size (1-1/4-inch NPT) drain fittings.
- Note in Figure 2-5 that a 3-inch clearance is required above the EconoCraft. Do not store articles on top of the unit.
- The EconoCraft weighs approximately 100 pounds. The counter area selected must be capable of supporting an operational weight of approximately 120 pounds to include the weight of water and food.
- The EconoCraft has capacity for one 12" x 20" x 2.5" Cafeteria Pan (model # SP-2.5 or PP-2.5). Convenient storage for pans should be considered when selecting the operating location.

If a satisfactory counter location is not available, consider using a model ES-2424 Equipment Stand. This stand, illustrated in Figure 2-4, is designed to support the EconoCraft, and meets the above criteria.

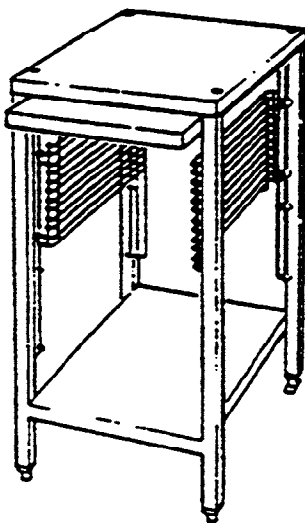
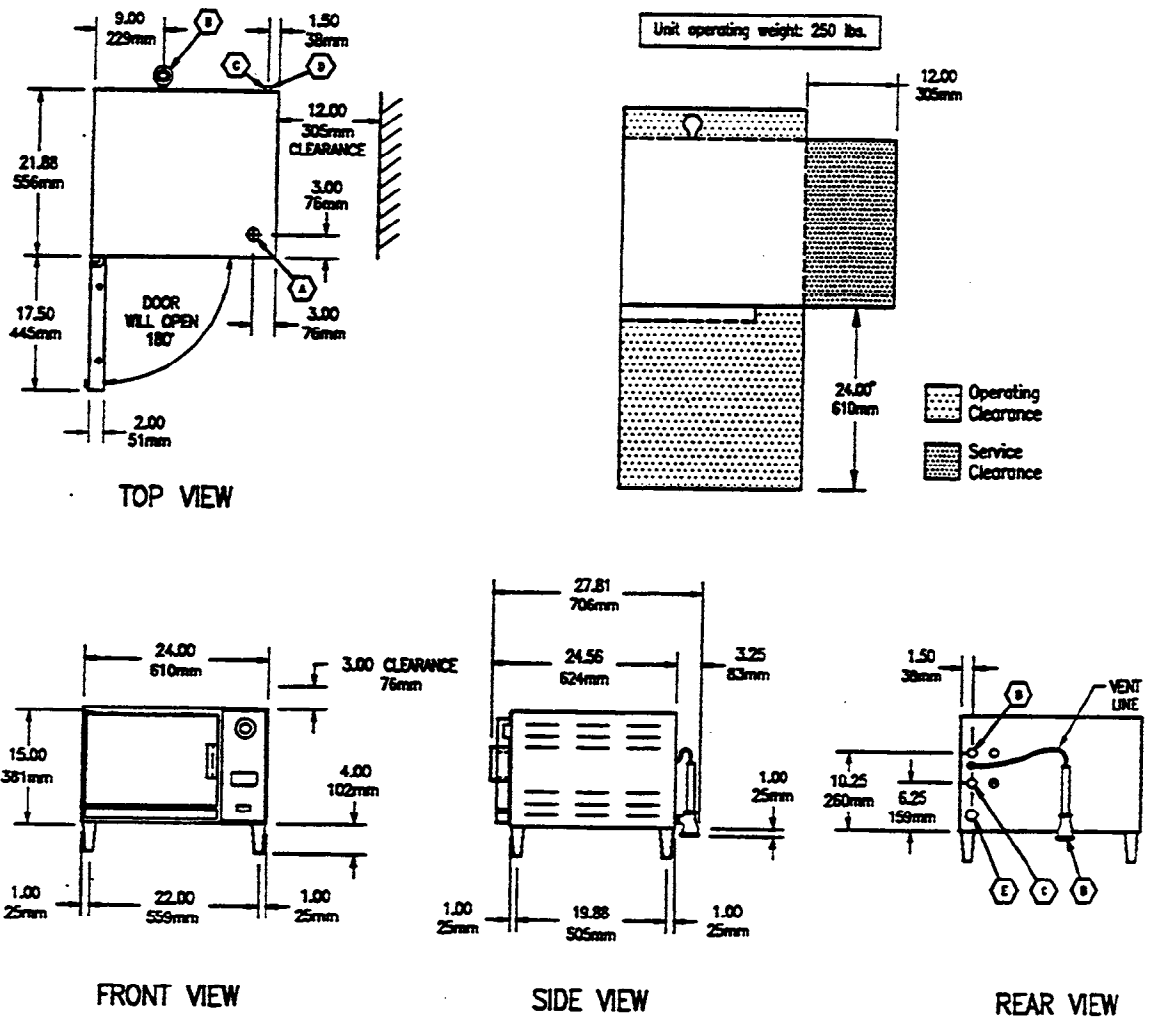

Figure 2-4. Equipment Stand



TOTAL CAPACITY				UTILITY CONNECTIONS			
3 - 12" X 20" X 2-1/2" Cafeteria Pans				Ⓐ Electrical Supply	Ⓓ Cold water		
6 - 12" X 20" X 1" Cafeteria Pans				Ⓑ Drain	Ⓔ Cable entrance		
2 - 12" X 20" X 4" Cafeteria Pans				Ⓒ Treated hot or quality cold water.			
ELECTRIC		WATER		DRAINAGE			
VOLTS	KW	RPH	AMPS	35 psi minimum 60 psi maximum Cold water only 1/4" N.P.T. to condensate. Treated hot or quality cold water. 1/4" N.P.T. to Steam Generator.		Drain 1" N.P.T., open connection to hub drain. Do not make solid connection. Do not use PVC plastic plumbing for drains.	
240	8	20	34				

Figure 2-5. EconoCraft Dimensions and Clearances

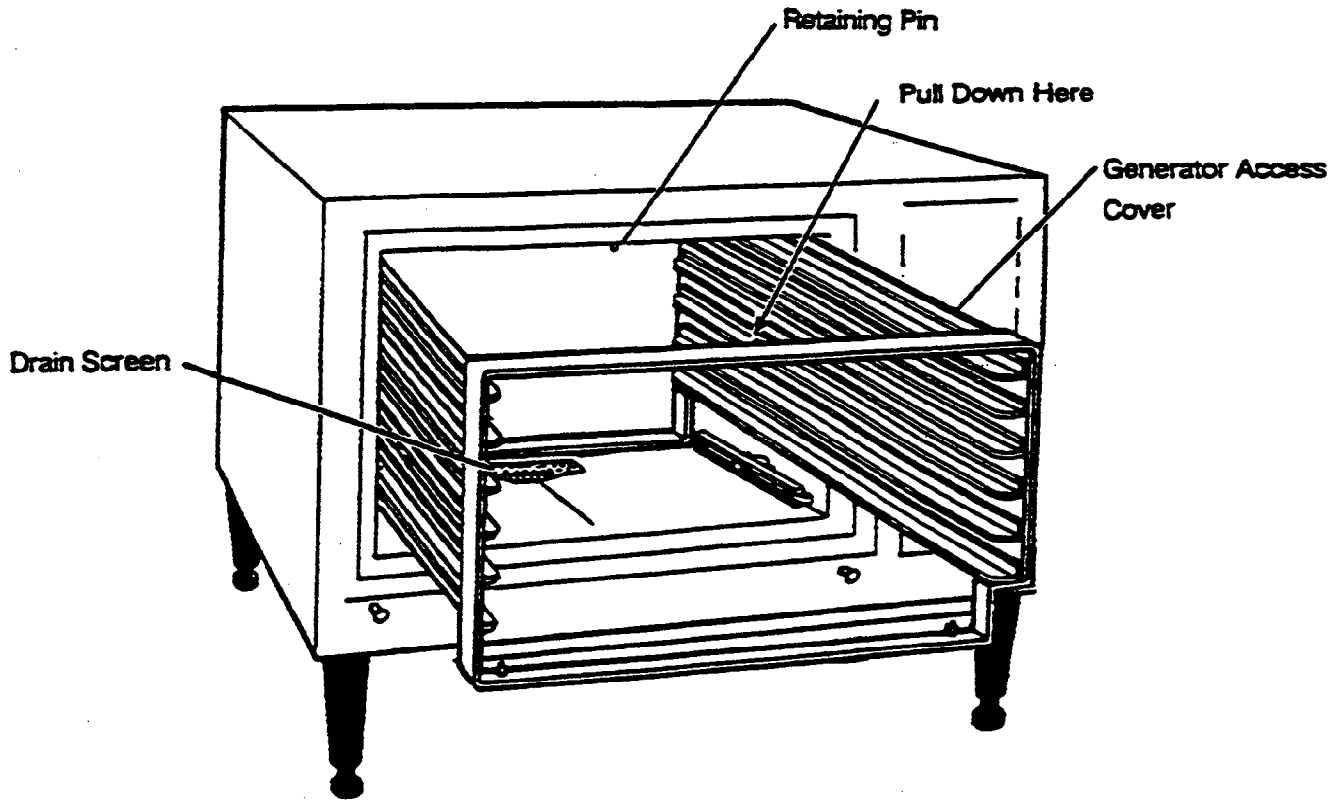

Figure 2-6. Pan Rack and Drain Screen Removal

INSTALLATION INSTRUCTIONS

After selecting and preparing the EconoCraft operating location, the steamer can be unpacked, positioned, and installed. This section of Chapter 2 details inspecting and positioning the EconoCraft. Installation and connection of the power, water, and drain lines are also detailed. After final setup and testing, the EconoCraft will provide years of reliable operation.

Assembly

Install the Drain Screen

1. Slide the pan rack out of the steamer. See Figure 2-6. Pull down on the center of the top front bar of the rack so it clears the retaining pin as the rack is slid out.
2. Install the drain screen over the drain hole at the rear of the compartment. The pin on the drain screen must face downward. The small flanged edge faces toward the front of the unit.
3. Slide the pan rack into the steamer compartment. Pull down on the top front bar of the rack so that it clears the retaining pin.

Install Four Legs

Do not install the EconoCraft without legs.

1. Place the EconoCraft on its left side.
 2. Check that the feet are fully retracted into the legs. Do not overtighten, the feet should easily screw in and out by using fingers only.
 3. Install all four (4) legs in the bottom of the EconoCraft.
 4. Turn the steamer upright.
-

Position and Level EconoCraft

For efficient operation, the steamer should be level both front to back and side to side. The legs of the EconoCraft are four inches long when the adjustable feet are fully retracted. The adjustable feet can be extended approximately two inches, providing adjustment for leveling the steamer.

1. Refer to the Installation Check List, Table 2-1. Check that all Preparation Tasks are complete. Check that all Unpacking and Assembly tasks are complete.
 2. Place the EconoCraft at the location where it will be used.
 3. Adjust the retractable feet of the Econocraft to level the unit.
-

Install and Connect the Free Air Vented Drain Lines

The drain outlet discharges exhaust steam and hot condensate from the steamer. The drain outlet **MUST** be free air vented to equalize the pressure in the EconoCraft with the atmosphere. Generating steam causes pressure to increase in the unit; cold water flow into the condenser creates a vacuum (low pressure) in the condenser. Without a free air vent, either high or low pressure in the compartment will cause malfunction or damage. The openings at the top of the vent pipe and drain outlet provide the EconoCraft with free air venting.

- Pressure build up in the steamer will cause steam and hot water leakage around the door.
- A vacuum **WILL** implode the steamer and cause permanent physical damage.

Furnishing and installing the fittings and drain line is the responsibility of the owner and/or installer. Figure 2-7 illustrates a drain layout recommended by Cleveland Range. Observe the following instructions to determine the pipe size, the number of fittings required, and the layout of the drain line path.

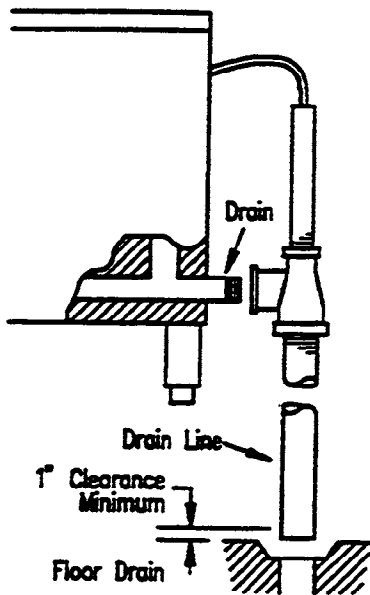

Figure 2-7. Drain Layout and Connections

WARNING

DEATH, INJURY, AND EQUIPMENT DAMAGE could result from improper installation of the drain outlet lines. THE DRAIN MUST BE FREE AIR VENTED.

Improper installation of these lines could void the EconoCraft warranty. The following restrictions are critical to the safety of personnel and equipment, and must not be violated under any circumstances.

Do not connect the drain line into PVC pipe, or any other drain material that cannot sustain 180° F.

Do not connect drains from any other equipment to the EconoCraft drain line.

Do not connect the drain outlet extension line directly to a floor drain or sewer line.

1. The drain lines must be installed in compliance with the Basic Plumbing Code of the Building Officials and Code Administrators International, Inc. (BOCA), and the Food Service Sanitation Manual of the Food and Drug Administration (FDA).
2. The pipe size used to extend the drain outlet to an open drain is determined by the total length of pipe and number of bend fittings required to reach the open drain.
 - If the drain outlet extension requires six feet or less of pipe, and no more than two elbows are required, use 1-inch pipe and fittings.
 - If the drain outlet extension requires six to twelve feet of pipe, and requires three or more elbows, use 1-1/4-inch pipe and fittings.
3. The drain line must have a gravity flow from the EconoCraft drain outlet to the floor drain. Do not install a p-trap in the drain line.
4. Free air venting requires a minimum of one inch clearance between the end of the drain line and the top of the floor drain.
5. When assembling the pipe and fittings of the drain line, apply a hardening type pipe sealant to the threads, and tighten them together FINGER TIGHT ONLY. DO NOT USE A WRENCH.
6. Do not connect the steamer drain to drains or plumbing of any other equipment. If drains of two or more units are connected together, low pressure can develop, causing an implosion and physical collapse of the steamer.
7. The EconoCraft is supplied with the drain assembly attached to the unit (Figure 2-7). The overflow tube functions in free air venting and must extend upward from the tee.

Install Electric Power Lines

Furnishing and installing the electrical power lines, switches, fuse boxes, connectors and their accessories is the responsibility of the owner and/or installer. Figure 2-8 illustrates an electrical layout recommended by Cleveland Range. When installing the electrical power lines and accessories, observe the following instructions.

1. In the United States, install the electrical power lines in accordance with local codes and/or the National Electric Code, ANSI/NFPA No. 70-1990 (USA).
2. In Canada, install the electrical power lines in accordance with local codes and/or the Canadian Electrical Code, CSA Standard C22.1 (Canada).
3. Install the proper size disconnect switch, circuit breaker or fuses, and wire and conduit to conform to all local codes and the national codes cited above. See Table 2-3 for wire requirements.

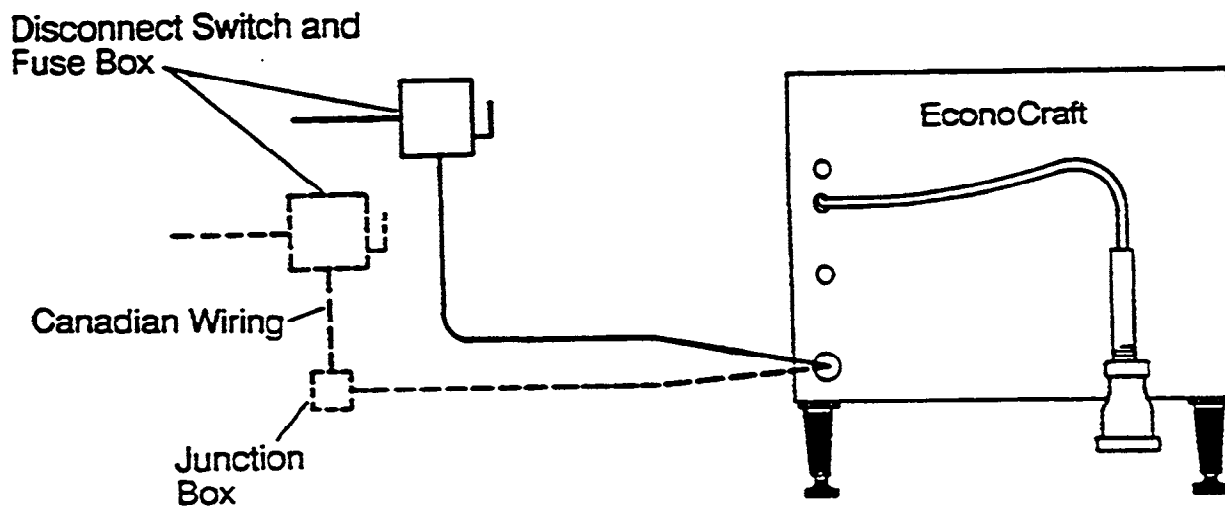

Figure 2-8. Electrical Layout

Table 2-3. Minimum Wire Requirements

LINE VOLTAGE	KILO-WATTS	LINE AMPS*	WIRE GAUGE**
208	8	23	10
220	8	21	10
240	8	20	10
380/220	8	13	10
415/240	8	12	10
440	8	11	10
480	8	10	10

*All 3 Phase

**Use solid copper wire rated for 75°C.

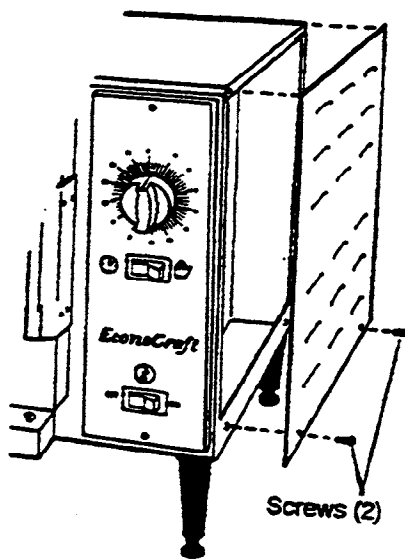

Figure 2-9. Access Panel Removal

4. Install a separate disconnect switch and fuses sized to line amps (see Table 2-3). The fuses may be an integral part of the disconnect switch or in a separate fuse box.
5. There should be a sufficient length of flexible conduit between the EconoCraft connector and the wall so the unit can be moved for service.
 - Canadian steamers are supplied with six feet of flexible conduit for compliance with Canadian Standards Association. The electrical supply line must end in a junction box behind the steamer for connection of the flexible cable from the steamer.
6. Each steamer **MUST** be electrically grounded by the installer.
7. The characteristics of the electric power supply must match the power requirements specified on the EconoCraft product information plate. The plate is located on the left side of the unit (refer to Figure 1-1 and 1-2).
8. EconoCrafts are wired for 3 phase, but can be converted to single phase. Contact an authorized service agency for more information.

Connect Electrical Line

Verify that the electric power lines have been properly extended from the external disconnect to the EconoCraft location. Connect the electrical lines to the terminal block inside the right side access panel as described below.

1. Move the EconoCraft so the access panel can be easily reached.
2. Remove the access panel by removing the two screws (Figure 2-9) that hold it in place. Save the screws.
3. Mechanically secure the flexible conduit to the electrical conduit access hole (Figure 2-10). (See Canadian Wiring Considerations.)
4. The terminal block and ground connection are near the front of the side opening. The unit has a terminal block for 3-wire DELTA connection.
5. Refer to the connection diagram, Figure 2-10, and connect the wires to the terminal block and ground connector accordingly.
6. The steamer **MUST** be electrically grounded by the installer.

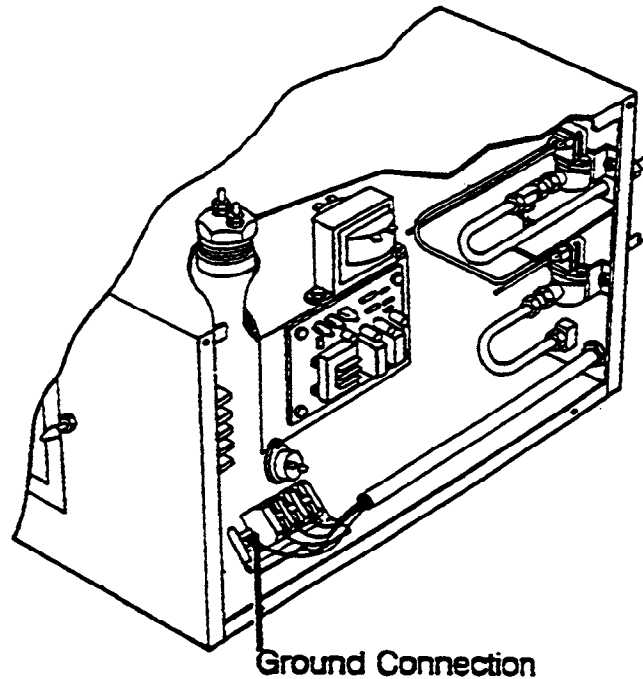

Figure 2-10. Connection Diagram

7. EconoCrafts are wired for 3 phase, but are convertible to single phase. Contact an authorized service agency for information on single phase connections.
8. If no further work is required inside the access panel, such as plumbing and leak checks, secure the access panel with the two mounting screws (Figure 2-9).

Canadian Wiring Considerations.

For all applications in Canada, install the electrical power lines in accordance with local codes and/or the Canadian Electrical Code, CSA Standard C22.1 (Canada).

- Canadian steamers are supplied with six feet of flexible conduit connected to the steamer and wired to the terminal block at the factory.
 - The electrical supply line ends in a junction box behind the steamer for connection of the EconoCraft flexible cable.
 - Connect the wires from the EconoCraft flexible cable to those in the junction box according to Figure 2-11.
 - The steamer **MUST** be electrically grounded by the installer.
-

Install Water Supply Lines

Furnishing and plumbing the water supply lines is the responsibility of the owner and/or installer. Figures 2-13, 2-14, and 2-15 illustrate plumbing layouts recommended by Cleveland Range. When installing water supply lines, observe the following instructions.

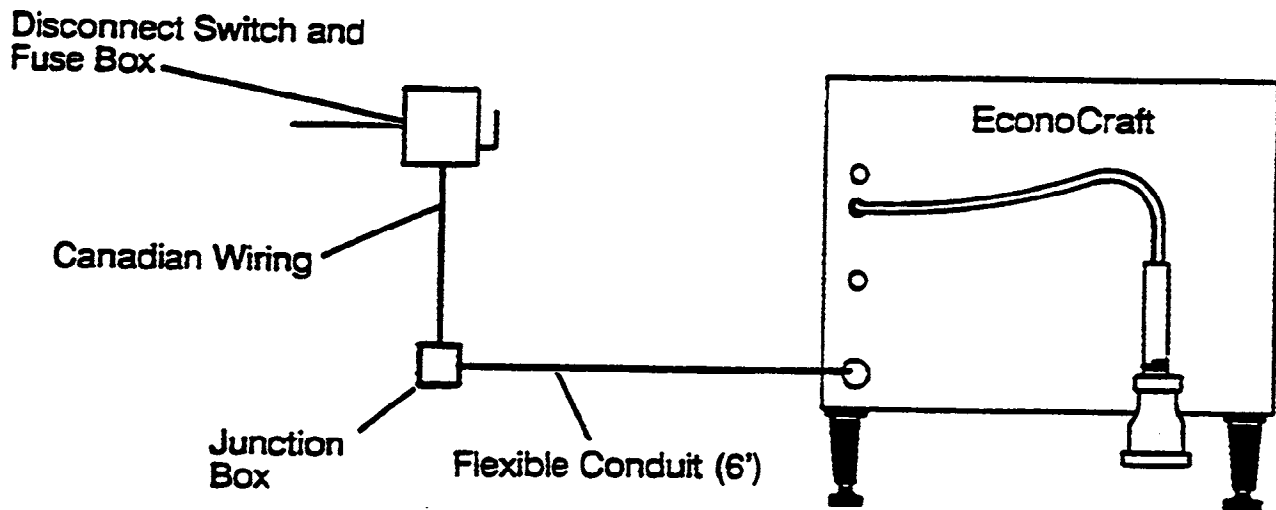

Figure 2-11. Canadian Connection Diagram

CAUTION

Do not connect warm or hot water supply to condenser connection. If hot or warm water is supplied to this connection, the steam condenser in the EconoCraft will not work.

1. Connect a COLD water supply to the condenser connection (Figure 2-1).
2. Supply water pressure must have a minimum dynamic pressure of 35 psi (2.4 kg/cm²) and a maximum static pressure of 60 psi (4.1 kg/cm²).
3. The recommended size for the water supply lines is 1/4-inch IPS. This is the size of generator and condenser connections on the rear of the EconoCraft. If larger lines are used, a pressure reducer must be installed in the supply line to maintain the pressure specified in #2, above.
4. The National Sanitation Foundation (NSF) requires installation of a check-valve in all supply lines in accordance with and as required by local plumbing codes.
5. When a water treatment system is not installed, Cleveland Range recommends the plumbing layout illustrated in Figure 2-13.
6. When installing a water treatment system, Cleveland Range recommends the plumbing layout illustrated in Figure 2-15.
 - The water supply to the condenser connection (Figure 2-1) can be untreated.
 - The treated water supply connects to the steam generator connection (Figure 2-1).
7. When installing a hot water heater, Cleveland Range recommends the plumbing layout illustrated in Figure 2-14.

Connect Water Supply Lines

Connect the water supply lines paying particular attention to the following. Refer to the appropriate section below for information on the desired connection: untreated, preheater, or SteamerGard.

1. Apply pipe dope or teflon tape to any threaded connection.
2. Flush the water supply lines before connecting the strainer.
3. When installing the water strainer(s), refer to Figure 2-12.
 - Use a strainer with a 40 mesh screen.
 - Make sure the arrow on the strainer body points in the direction of flow into the steamer.
 - Install the strainer so the access nut points down.
4. If water supply lines are larger than 1/4-inch IPS, install a pressure reducer to maintain the EconoCraft pressure requirements specified in Install Water Supply Lines (page 15).

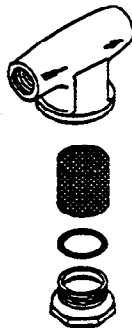

Figure 2-12. Water Strainer

Single Untreated Water Connection

1. Refer to Figure 2-13.
2. Verify that all components are installed in the single line before the tee that divides the water flow between the steam generator and condenser.

Double Water Connection With Preheater

1. Refer to Figure 2-14.
2. Verify that each line connected to the steamer has a check valve and strainer installed.
3. Verify that the hot water heater connects to the steam generator connection. The condenser must have a cold water input to operate properly.

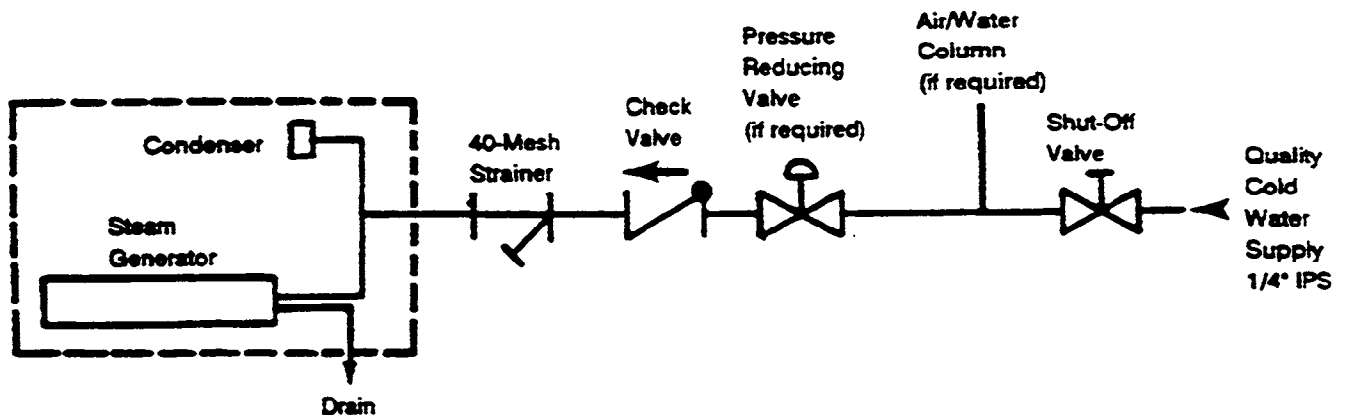

Figure 2-13. Single Water Connection

Double Water Connection With SteamerGard

1. Refer to Figure 2-15 and the SteamerGard installation manual.
2. Verify that each line connected to the steamer has a check valve and strainer installed.
3. Verify that the SteamerGard water treatment system has been installed according to the SteamerGard installation manual. The check valve must be installed between the EconoCraft and the SteamerGard.

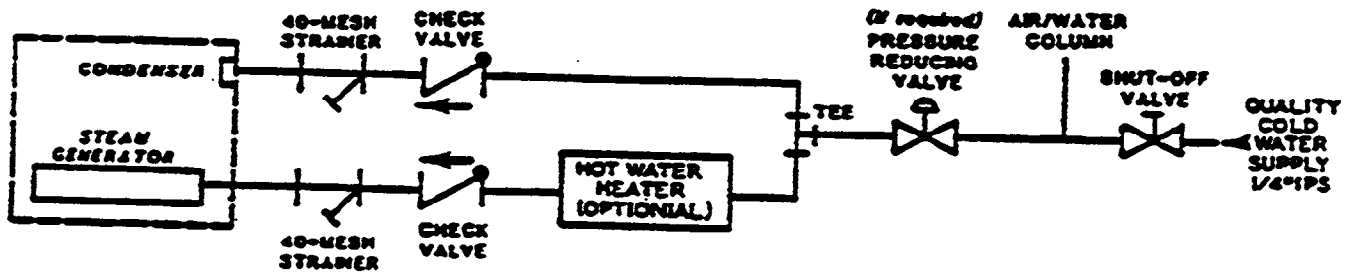

Figure 2-14. Double Water Connection with Hot Water Heater

Testing Water Supply Lines

1. Check that the condenser line from the steamer (Figure 2-16) is positioned in the top of the overflow tube. A clip secures the line to the tube.
2. Check all connections for proper tightness. Remove two screws to remove the access panel to inspect water connections inside the steamer; refer to Figure 2-9. Save the screws.
3. Open the water supply and other inlet valves.

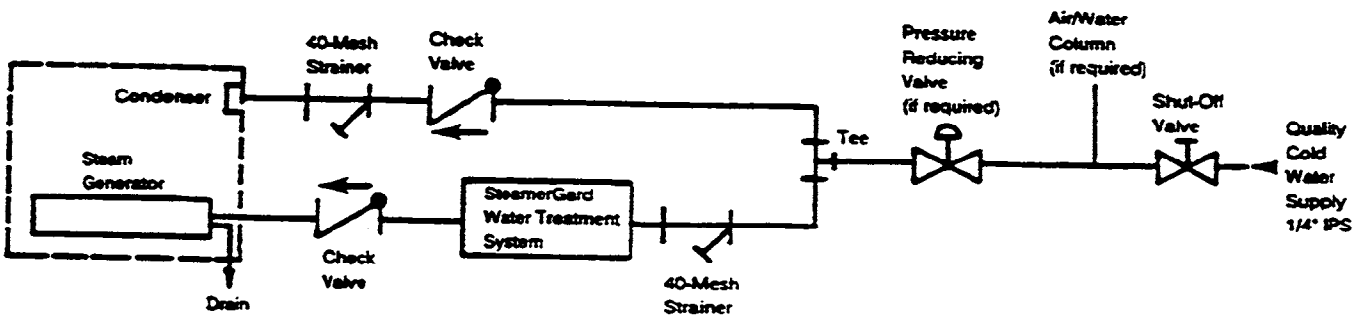

Figure 2-15. Double Water Connection with SteamerGard

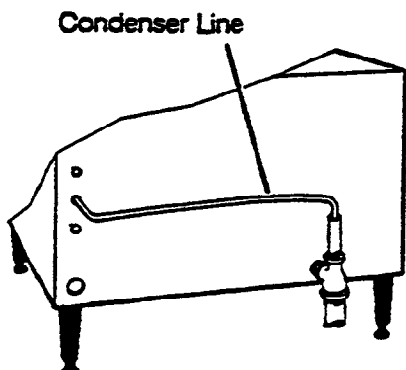

Figure 2-16. Condenser Line

Final Setup And Checkout

4. Check all lines and connections for leakage, both inside and outside the steamer.
5. If no further work is required inside the EconoCraft at this time, replace the access panel with the two screws (Figure 2-9).

This test procedure checks proper electrical, water, and drain connections to the EconoCraft. The test also verifies basic operation of the steamer.

Setup

1. Check that the water supply line valves are open.
2. If a SteamerGard water treatment system is installed, refer to the SteamerGard manual and start the system. If there is a valve between the SteamerGard and the EconoCraft, be sure it is open.
3. Refer to electrical schematic, Figure 2-8, and Table 2-3. Minimum Wire Requirements. Verify that the proper size fuses or breakers are installed. Check that the POWER switch on the EconoCraft is in the OFF position by pressing the left side of the switch. Turn on electric power to the EconoCraft at the fused disconnect switch.
4. Open the steamer door. Check for proper installation of the drain screen and pan rack.
5. Refer to Figure 2-17; check that the drain lever is positioned in the drain closed position and that the drain plug is inserted in the cylinder opening. When the plug is inserted (closed), the O-ring rests against the edge of the cylinder.
6. Install the drip tray at the front of the steamer below the door (Figure 1-1).

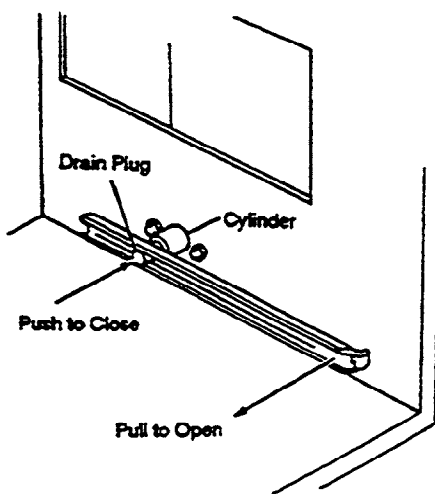

Figure 2-17. Drain Lever and Plug

MANUAL Test

1. Refer to Figure 2-18. Press the TIMED/MANUAL switch to the MANUAL position by pressing the right side of the switch.
2. To check the timing operation of the unit, have a watch or clock ready. Read through step 3 before turning the unit ON in order to be ready for the indications listed in step 3.

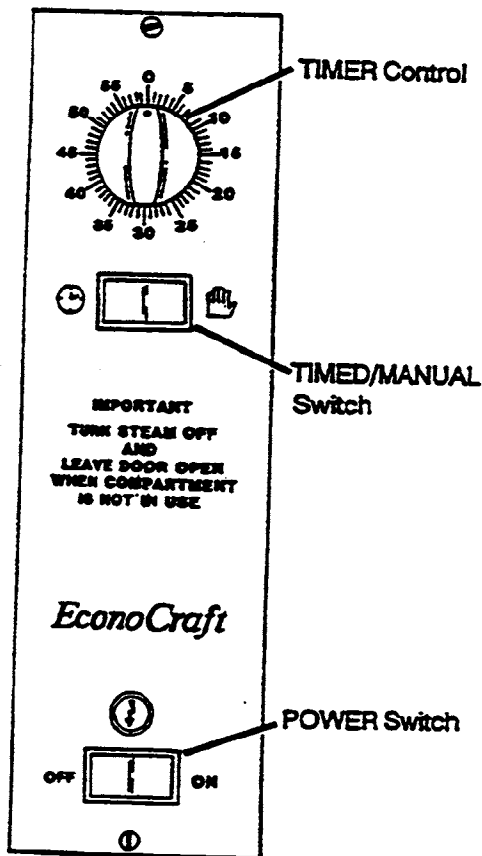

Figure 2-18. Control Panel

3. Energize the steamer by pressing the right side of the POWER switch. Check for the following indications. The times listed are approximate and occur from the time the unit is energized. Timing can vary, depending on water supply temperature and pressure.

- 0 seconds - red light on POWER switch energizes.
- 5 seconds - fill valve opens (click sound) and water begins to fill the steam generator (water flow sound).
- 45 seconds - second click sound indicates the operation of the heater contactor.
- 50 seconds - third click sound indicates the fill valve closing (steam generator full).
- A gurgling sound indicates the heaters are working and the unit is beginning to generate steam.
- 2 minutes and 30 seconds - Steam begins to waft from generator into compartment.

4. Place the TIMED/MANUAL switch in the TIMED position by pressing the left side of the switch. This turns the steamer OFF. The light on the switch turns OFF and the buzzer sounds for 3 seconds.

TIMED Test

1. If not already done, perform SETUP.
2. Refer to Figure 2-18, and set the TIMED/MANUAL switch to the TIMED position.
3. Check that the POWER switch is in the ON position (red switch indicator lighted).
4. Set the TIMER control for 10 minutes.
5. Close compartment door.
6. During the 10-minute test, the EconoCraft will produce steam. Check for clicking sounds from time to time as the water fill valve opens and closes and the heater contactor turns on and off.
7. Observe a small stream of warm water flowing out of the drain pipe and no water coming out of the top of the overflow tube. Check for steam leaks around the door. If no water flows out of the drain pipe, or the flow is very hot or cold to the touch, adjust the condenser flow as described below.
8. After 10 minutes, the TIMER points to 0 and the buzzer sounds for 3 seconds. The compartment will be full of steam.

WARNING

SEVERE BURNS may result to eyes, nose, mouth or skin exposed to hot steam.

Avoid hot steam. When opening steamer, crack door to allow steam to vent before looking or reaching into steamer.

Do not reach into steamer or handle hot items without wearing dry heat-proof gloves. Wet or damp gloves conduct heat, and will cause burns when touching hot items.

Once the MANUAL and 10-minute TIMED tests are complete, the Econo-Craft is ready to operate. The TIMED test has preheated the unit which will remain heated as long as the door is not opened frequently.

- If no TIMED or MANUAL tests have been done, it will take approximately 5 minutes for the steam generator to reach operating temperature.

Condenser Flow Adjustment

Perform this procedure only if needed as noted in the TIMED test above.

1. Remove the access panel by removing the two screws that hold it in place; see Figure 2-9. Save the screws.
2. Press the POWER switch to ON.
3. Press the TIMED/MANUAL switch to MANUAL and allow the steamer to warm for 10 minutes.
4. Refer to Figure 2-19 and adjust the condenser flow adjust valve until the water flow out of the drain pipe is lukewarm.
5. Replace the access panel and secure with the two screws (Figure 2-9).

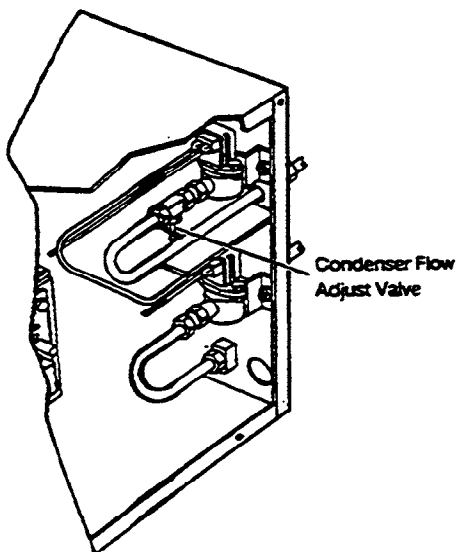

Figure 2-19. Condenser Flow Adjust Valve

CHAPTER 3. OPERATION

INTRODUCTION

To get the full advantage of steam cooking, the Cleveland Range EconoCraft must be properly operated as described in this chapter.

WARNING

DEATH, INJURY, AND EQUIPMENT DAMAGE could result from improper operation of the Econo-Craft. Be sure steamer has been installed correctly according to the installation instructions in Chapter 2 before starting operation.

OPERATIONAL SAFETY

WARNING

SEVERE BURNS may result to eyes, nose, mouth or skin exposed to hot steam. Avoid hot steam. When opening steamer, crack door to allow steam to vent before looking or reaching into steamer. Do not reach into steamer or handle hot items without wearing dry heat-proof gloves. Wet or damp gloves conduct heat, and will cause burns when touching hot items.

The EconoCraft will require minimum servicing if it is properly operated and maintained by trained personnel. The following steps will help keep the steamer in good condition.

1. Conduct regular steamer inspections. Check for water, door seal and drain leaks, clogged drain, steam generator scale buildup, and steamer control malfunctions.
2. Train all personnel who will use the steamer. Make sure personnel know how to operate the steamer, clean exterior and interior, and wash out and descale the steam generator. Personnel must also be able to recognize problems and know how to take corrective action.
3. Follow the instructions for steamer and steam generator maintenance.
4. Use only factory authorized replacement parts. This will maintain Underwriters Laboratories (UL) and/or Canadian Standards Association (CSA) certification, and all approvals to protect warranty coverage.
5. Never allow unauthorized personnel to service the EconoCraft.
6. Maintain written records of steamer maintenance.
7. Before operating the EconoCraft, verify that the drain screen, pan rack, and drip tray are installed.

CONTROL PANEL

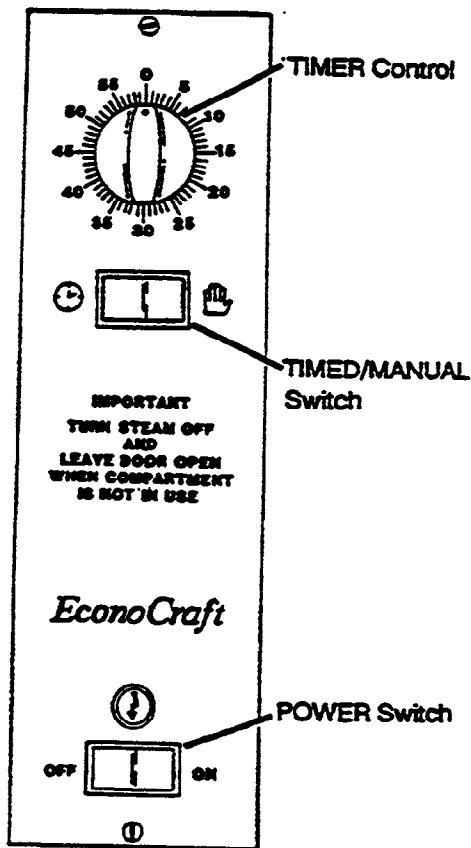

Figure 3-1. Control Panel

CAUTION

Press switches with finger tip only. Do not use finger nails, kitchen utensils, or anything sharp to press switches.

Refer to Figure 3-1 for location of panel controls.

1. POWER Switch

The POWER switch at the bottom of the control panel controls electrical power to the steamer. Pressing the right side of the switch turns the unit ON. A red indicator on the switch turns ON when the unit energizes.

Pressing the left side of the switch turns the unit OFF.

2. TIMED/MANUAL Switch

The switch below the TIMER dial selects MANUAL or TIMED operation. Pressing the right side of the switch sets the unit in MANUAL. When the EconoCraft energizes, a red indicator on the switch indicates MANUAL mode.

Pressing the left side of the switch sets the unit for TIMED mode.

3. TIMER

The circular dial at the top of the control panel allows the user to select the time of operation in the TIMED mode. The dial can be set for up to 60 minutes.

DRAIN PLUG

CAUTION

Do not try to slide the drain plug completely out of the cylinder.

The generator drain plug is located inside the steamer compartment near the lower center of the right side; see Figure 3-2. The drain plug slides in and out of a cylinder that protrudes from the side of the compartment.

To close the plug, push in on the lever as shown on Figure 3-2. The plug is fully inserted when the O-ring on the plug seats against the edge of the cylinder.

To open the plug, pull the drain handle to the left. This causes the drain plug to slide out of the cylinder. The drain plug is open when the hole in the plug comes into view, allowing water to drain from the steam generator. Do not try to slide the plug completely out of the cylinder.

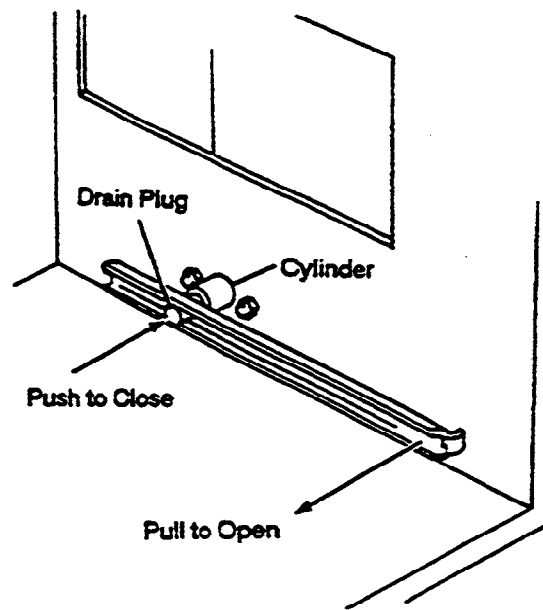

Figure 3-2. Drain Lever and Plug

MANUAL MODE

The **MANUAL** mode allows continuous operation of the steamer. Operating in **MANUAL**, the steamer continuously produces steam until the operator switches the **TIMED/MANUAL** switch to the **TIMED** position or turns the unit **OFF** with the **POWER** switch. When using **MANUAL** mode, and the proper cooking time is not known, the operator must check the food periodically to prevent overcooking.

1. Pressing the **TIMED/MANUAL** switch to the right starts **MANUAL** cooking. The red light on the switch turns on.
2. When cooking is completed, pressing the **TIMED/MANUAL** switch to the left stops the steaming operation. The red light on the switch turns off and the buzzer sounds for 3 seconds.

TIMED MODE

In the **TIMED** mode the unit generates steam for the time selected on the **TIMER**. The **TIMED** mode can be used to select a specific cooking time, for example, according to food package or recipe instructions.

1. Pressing the **TIMED/MANUAL** switch to the left (switch light is **OFF**), sets the unit for **TIMED** operation.
2. Turning the **TIMER** dial to the time desired for cooking starts the cooking cycle. The **TIMER** can be set for up to 60 minutes.

3. Steaming stops after the time set on the dial has elapsed. The buzzer sounds for 3 seconds to indicate that cooking has stopped.

STARTUP AND PREHEAT

1. Check that the drain plug is inserted in the cylinder and the compartment drain is clear of debris. The drain screen and pan rack must be installed in the steamer compartment. Close the steamer door.
2. Check that the water supply valves are open and that the electrical disconnect is closed.
3. Press the **TIMED/MANUAL** switch to the **TIMED** (left side in) position.
4. Press the **POWER** switch **ON**. The red light on the **POWER** switch turns **ON** and the buzzer sounds for 3 seconds. Water flows in and fills the steam generator.
5. Set the **TIMER** dial at 10 minutes. The heaters will energize and preheat the steamer. When the time elapses, the buzzer sounds for 3 seconds, indicating the EconoCraft is ready for cooking.

COOKING

1. Clean any debris out of the steamer compartment.
2. Preheat steamer compartment as described above.

CAUTION

Some foods drip juices. Use a solid catch pan under perforated pans used for steaming food that will drip juices. Failure to use a catch pan can cause a clogged drain.

3. Put food into pan and slide pan into pan rack inside the steamer. Do not place pans on the bottom of the compartment. When cooking foods that will drip, such as meats, poultry, or fish; put a solid catch pan in the bottom slide of the rack. Close the steamer door.
4. For best cooking results, use a shallow (2-1/2 inch deep) perforated pan without cover (Cleveland Range model number PP-2.5). This gives the best heat transfer and shortest cooking time for food.
5. Select either **TIMED** or **MANUAL** cooking. Refer to **TIMED** and **MANUAL** cooking instructions below.

WARNING

SEVERE BURNS may result to eyes, nose, mouth or skin exposed to hot steam.

Avoid hot steam. When opening steamer door, crack the door open to allow steam to vent before looking or reaching into steamer.

Do not reach into steamer or handle hot items without wearing dry heat-proof gloves. Wet or damp gloves conduct heat, and will cause burns when touching hot items.

CAUTION

Press switches with finger tip only. Do not use kitchen utensils or anything sharp to press switches.

NOTE

Although steamer door can be opened at any time during cooking, this causes the temperature in the compartment to decrease. The cooking time may then need to be increased.

TIMED Cooking

1. Slide food tray with food into steamer compartment.
2. Set **TIMED/MANUAL** switch to the **TIMED** position.
3. Set the **TIMER** dial to desired cooking time.
4. Food starts cooking.
5. At the end of the preset cooking time, steaming stops and buzzer sounds for 3 seconds.
6. Carefully open steamer door and remove food.

MANUAL Cooking

1. Slide food tray with food into steamer compartment.
2. Press the **TIMED/MANUAL** switch to the **MANUAL** position. The red light on the switch turns ON.
3. Food starts cooking.
4. At end of cooking time, press the **TIMED/MANUAL** switch to the **TIMED** position. The red light on the switch turns OFF and the buzzer sounds for 3 seconds.
5. Carefully open steamer door and remove food.

DRAIN STEAM GENERATOR (Every 4 hours)

For units without a water treatment system, this procedure must be performed after each 4 hours of operation to maintain warranty coverage. Draining the generator at more frequent intervals will help decrease mineral buildup in the generator. See Water Quality Requirements on page 7.

For units with treated water supply, drain the generator as necessary in the SHUT DOWN procedure.

1. Turn the unit OFF with the POWER switch on the control panel. Red indicator on switch turns OFF.
2. Drain the generator. Open the drain plug by pulling the lever to the left. The drain plug and lever are located inside the steamer compartment on the right side near the bottom. The hole in the plug comes into view when the plug opens. Do not try to pull the plug completely out of the cylinder. Refer to Figure 3-2.
3. When the generator has drained, close the drain plug by pushing the lever so that the drain plug inserts into the cylinder and the O-ring is flush against the cylinder.
4. The EconoCraft can now be restarted (see STARTUP and PREHEAT section).

SHUT DOWN (At end of day or shift)

This procedure must be performed at the end of each day or shift to maintain warranty coverage.

1. Turn off electrical power at the disconnect switch.
2. Close the water supply valves.

WARNING

SEVERE BURNS may result to eyes, nose, mouth or skin exposed to hot steam. Avoid hot steam. When opening steamer door, allow steam to vent before reaching into steamer. Do not reach into steamer or handle hot items without wearing dry heat-proof gloves. Wet or damp gloves conduct heat, and will cause burns when touching hot items.

3. Open the steamer door and allow the steamer to cool down.

WARNING

Inside of steamer stays hot for a long time. Be careful when cleaning inside steamer compartment.

4. Before draining, while water is still warm, brush the generator with a soft brush, going over the probes, elements, and sides of generator. This removes scale before it hardens and prevents scale buildup.
5. Open the drain plug by pulling the front of the drain lever to the left. The drain plug and lever are located inside the steamer compartment on the right side near the bottom.
6. Remove the pan rack. Wash and rinse separately or run it through a dishwasher according to health requirements.
7. Rinse the inside of the steam generator with clean water.
8. Wipe heater elements and water level probes located inside the steam generator with a damp cloth. Take care not to damage the components in the generator.
9. Wipe the interior of the steam generator.
10. Inspect the steam generator for scale buildup. Perform steam generator descaling as required.
11. Remove any spilled food from inside compartment and make sure the drain screen is clear. Wash the interior of the compartment thoroughly. Use a soft bristle brush to remove stubborn food particles. Do not use abrasive cleaning compounds or steel wool. Rinse inside of steamer compartment with clean water.

WARNING

Let rinse water drain through compartment drain opening. If water does not drain freely, drain lines must be cleaned before cooking again. Clogged or slow drains are dangerous because hot water may spill out when opening compartment doors during or after a cooking cycle.

12. Being careful not to allow any residue to fall down the drain hole, remove drain screen, wipe clean, and replace over drain hole.
13. Clean the door assembly.
 - Remove the door gasket assembly (Figure 3-3).
 - Hold the gasket assembly at the bottom so that it does not fall when the steel pins are removed. Remove the pins by pulling up on the black

knobs that protrude at the top of the steamer door. The gasket assembly will now fall free from the door.

- Clean all surfaces of the gasket assembly as well as the inside of the door.
 - Replace the gasket assembly by holding the gasket assembly against the door and inserting the pins. Make sure the pins insert correctly in the holes of both the door and the gasket assembly.
14. Replace the pan rack.
 15. Close the drain plug by pushing the lever so that the drain plug inserts into the cylinder and the O-ring is flush against the cylinder.
 16. Wipe the exterior with a damp cloth only. Do not hose down equipment.
 17. After cleaning, leave the steamer door open until the next steamer operation. This prevents compartment odor buildup and increases door gasket life.

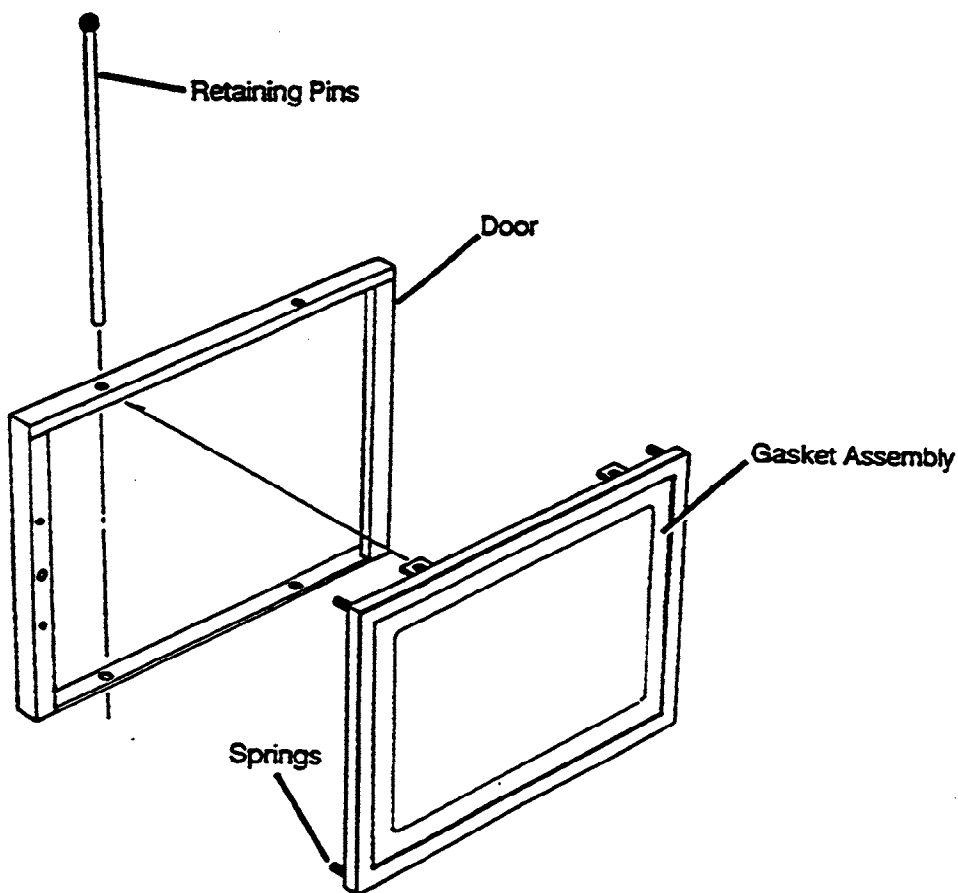

Figure 3-3. Door Gasket Assembly

CHAPTER 4. PREVENTATIVE MAINTENANCE AND TROUBLESHOOTING

INTRODUCTION

Maintenance on the steamer must be performed on a regular basis to keep the unit running properly. Follow the maintenance instructions in this chapter and problems will be kept to a minimum. As with any preventative maintenance schedule, the frequency of steamer maintenance may need to be increased, depending on equipment usage and water quality. If problems do occur, refer to the Troubleshooting Guide on page 34. For more information on products and services, contact your nearest Authorized Service Representative.

MAINTENANCE RECORDS

Make a file solely for maintenance records and keep a written record of daily, weekly, and yearly maintenance and when the steamer is descaled. These records will protect warranty coverage and help personnel to know when to perform maintenance functions.

DAILY MAINTENANCE

Drain Steam Generator (Every 4 Hours)

Drain the generator at least every 4 hours according to Drain Steam Generator instructions on page 28, Chapter 3, Operation.

Clean EconoCraft

Clean interior and exterior of EconoCraft according to instructions of SHUT DOWN on page 28, Chapter 3, Operation.

WEEKLY MAINTENANCE

Clean Drain

WARNING

The steamer is equipped with a drain screen in the back of the cooking compartment. The steamer should never be operated without the screen in place. This screen prevents large food particles from entering and possibly blocking the drain line. Any blockage of the drain line may cause a slight buildup of back pressure in the compartment resulting in steam leaks around the door gasket. It also may adversely affect the convection action of the steam in the compartment, which is necessary for optimum performance.

1. Inspect the drain screen and line for blockage.

2. Clean drain with a USDA approved drain cleaner once a week. Follow the instructions of the manufacturer of the cleaner.
3. Flush drain with clean water.

Descale Steam Generator

Regardless of use, descale steam generator at least once a week. If steam generator scale buildup is a frequent problem, install a water treatment system for the steamer. Cleveland Range, Inc. recommends use of the descaling kit (part number 101751). Full descaling may take more than one application and more than several hours. The frequency of steam generator descaling depends upon water quality and daily steam generator drain and washout. See Water Quality Requirements on page 7. Perform descaling until all scale buildup is cleaned out.

If professional descaling is required, contact your Cleveland Authorized Service Agent for a Preventative Maintenance Program for the steamer.

CAUTION

Do not scrape heating elements or water level probes with solid or sharp tools.

1. Press POWER switch to OFF.
2. Press TIMED/MANUAL switch to TIMED. Check that the TIMER is set to 0.
3. Open the drain plug by pulling the lever to the left. Allow steam generator to drain.
4. Allow time for the steamer compartment and steam generator to cool down.
5. Remove pan rack from compartment.
6. When generator has completely drained, close drain plug by pushing lever to the right.
7. Press POWER switch to ON. Water starts to fill the generator. Close the compartment door.
8. When the generator is full, the fill valve shuts and the water level in the generator stops rising. Pour one cup of vinegar into generator. Close steamer door.

NOTE: Companies such as Economic Laboratories (Limeway), Dubois Chemicals, Kert Chemical (Armalac), Refco (Refco Solv), and others sell recommended non-toxic deliming products. When using deliming solutions, follow the manufacturer's instructions.

9. Set **TIMER** dial to 15 minutes. Generator starts steaming.
10. When steaming time elapses, open steamer door, open the drain plug, and allow generator to drain completely.
11. When the generator has drained, close the drain plug.
12. Inspect the inside of the generator for scale. If needed, repeat the descaling procedure.

NOTE: Contact service representative or manufacturer for descaling kits or for information on descaling procedures.

YEARLY MAINTENANCE

Clean Water Line Strainer

Clean the water line strainer(s) at least once a year as follows:

1. Close the water supply valves to the steamer.
2. Unscrew the filter cap from the bottom of the strainer which is located in back of the steamer. Refer to Figure 4-1.
3. Remove the filter screen and wash it with clean water. Refer to Figure 4-1.
4. Put screen back into cap and screw cap into strainer.
5. Open water supply valve(s) and check for water leaks.

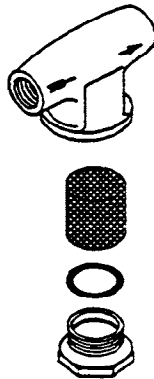

Figure 4-1. Strainer

TROUBLESHOOTING GUIDE

This troubleshooting guide includes a list of symptoms that may be encountered during routine operation and maintenance. The first column on the left (problem) describes these symptoms. The second column lists possible causes for the problem listed in column one. The third column lists remedies and or references for the problems and causes in columns one and two. The causes and remedies are listed

in the order they should be checked, with the least costly and easiest to repair listed first. The third column also refers to notes that are grouped at the end of the troubleshooting guide. Refer to these notes when instructed to do so. Do not try to correct a problem that requires an authorized service representative as this may adversely affect warranty coverage.

PROBLEM	POSSIBLE CAUSE	REMEDY/REFERENCE
Switch light does not turn on when POWER switch is pressed on.	Power turned off at disconnect.	Turn on power at disconnect.
POWER switch light on and steamer does not make any steam in MANUAL or TIMED mode.	Water supply to steamer shut off.	Open water supply valves.
	Water line filter is clogged.	Clean out water supply filter.
	Inoperative controls or solenoid.	See note #1.
Abnormal amount of steam coming from drain.	Water supply to condenser turned off.	Open water supply valve. Check condenser flow adjust valve.
	Water line strainer is clogged.	Clean out water supply strainer.
	Water supply line to the condenser blocked, broken, or leaking.	Repair or replace water supply line. See note #1.
	Inoperative condenser solenoid.	Replace solenoid. See note #1.
	Inoperative controls.	Turn off electricity. See note #1.
Steam and/or water draining around cabinet door.	Drain clogged or covered.	Clean drain with USDA approved drain cleaner.
	Door seal or door parts worn.	See note #1.
	Steamer not level.	See note #2.
Steam flow does not stop when timer stops.	Inoperative controls inside cabinet.	Turn off electricity. See note #1.
Water leaking from bottom of cabinet.	Broken or loose plumbing inside steamer cabinet.	Turn off electricity and close water supply valve(s). See note #1.
Water leaking from water pipes or drain lines.	Plumbing needs repair.	See note #3.

TROUBLESHOOTING GUIDE *(continued)*

Food takes too long to cook.	Pan too close to the bottom of cabinet.	Put pan in slots near top of cabinet.
	Steam generator scale buildup.	Descal steam generator with USDA approved descaler.
	Cabinet overloaded with too much food.	Put less food into pan. Use only one pan.
	Voltage too low for unit.	See note #4.
	Suggested cooking times are usually listed for cooking at sea level.	Extend cooking times for altitudes above 2500 feet.
Cabinet bottom dirty with food drippings.	Juices and/or food leaking from pan.	Put a solid pan under perforated pan to catch drippings. Put less food in pan.

TROUBLESHOOTING NOTES

WARNING
Do not attempt to open compartment door while steamer is hot.

NOTE Some unit problems such as steam generator flooding or no water in steam generator can be caused by dirt or scale on water level probes inside steam generator. Try descaling steam generator.

1. If problem is inside the steamer, call an authorized service representative. Cleveland Range, Inc. will not pay for warranty repairs by unauthorized repair centers.
2. Proper installation of the EconoCraft is the responsibility of the owner or installer. Refer to Cleveland Range, Inc. warranty on the inside front cover.
3. Repairs to external plumbing should be done by a Licensed Plumber.
4. Repairs to external wiring should be done by a Licensed Electrician.

For more information on products and services, contact your nearest Authorized Service Representative. Call factory for a preventative maintenance program, descaling kits, descaling information, and water treatment systems: USA: 800-782-0040, Canada: (416) 663-7770.

TROUBLESHOOTING QUICK TEST

The following table provides procedures and indications that will help qualified repair personnel to identify properly operating components.

Before starting the test, check that electrical power and water supply are available to unit and that water supply valves are open.

Perform the steps in column 1.

Check the responses in column 2.

Correct responses in Column 2 indicate that the components in column 3, as well as the ones above it, are operating correctly.

TROUBLESHOOTING QUICK TEST

Column 1	Column 2	Column 3
1. Turn on power at disconnect.		
2. Press TIMED/MANUAL switch to TIMED.		
3. Press EconoCraft POWER switch to ON.	Red indicator on POWER switch ON	POWER switch, Transformer
	Generator starts to fill	Control board, Fill solenoid
	Condenser water flows	Condenser solenoid
	Generator stops filling	High level probe
	Generator heats and produces steam	Low level probe, Heater contactor, Heater element
Press TIMED/MANUAL switch to TIMED	Contactor clicks OFF Steaming stops Buzzer sounds	Buzzer
	Condenser flow stops	Condenser valve
	Generator stops filling	Fill valve
Set TIMER to 10 minutes	Contactor clicks ON Steaming starts Condenser flow	All circuits
	TIMER at 0 Buzzer sounds Steaming stops	All circuits

CHAPTER 5. ELECTRICAL SYSTEM

INTRODUCTION

This chapter is exclusively for Cleveland Range authorized service representatives. These representatives should be experienced in the service, repair and maintenance of food service equipment in general, and with Cleveland Range equipment specifically. The service representative must thoroughly understand Chapters 1 through 4 of this manual before applying any of the information or instructions in this chapter. This chapter includes:

- An overview of the Econocraft electrical circuits
 - A functional description of the major components
 - A guide for testing the major components
-

Figures And Illustrations

Most illustrations in this chapter are on the same page or near the text in which they are first referenced. However, the Electrical Wiring and Schematic Ladder Diagram are included with the other service drawings in Chapter 6. These electrical drawings are Figures 6-2 and 6-3.

ECONOCRAFT ELECTRICAL CIRCUITS

There are three parts to the Econocraft circuitry: the High Voltage Circuit, the 120 VAC Circuit, and the Low Voltage Control Circuit. Refer to the Functional Block Diagram, Figure 5-1.

High Voltage Circuit

The High Voltage Circuit draws power directly from the external supply lines to power the heater elements, and the primary of the transformer. The high voltage value depends on local supply line voltage. The required characteristics of the external power supply are listed on the EconoCraft Product Identification Plate, as described in Chapter 1.

While the main power switch is ON, line power energizes the primary of the transformer. When the control circuits call for operation, contacts of the heater contactor close to power the heater elements.

120 VAC Circuit

The transformer secondary supplies power to the 120 VAC components through the ON/OFF switch. The 120 VAC components include:

- ON/OFF Switch
- TIMED/MANUAL Switch
- Fill Solenoid Valve
- Condenser Solenoid Valve
- Mechanical Timer
- 3-Second Timer and Buzzer
- Heater Contactor coil
- High Temperature Level Switch
- Water Level Control Unit

NOTE: The Water Level Control Unit, the Timer, and the TIMED/MANUAL Switch control operation of the 120 VAC components.

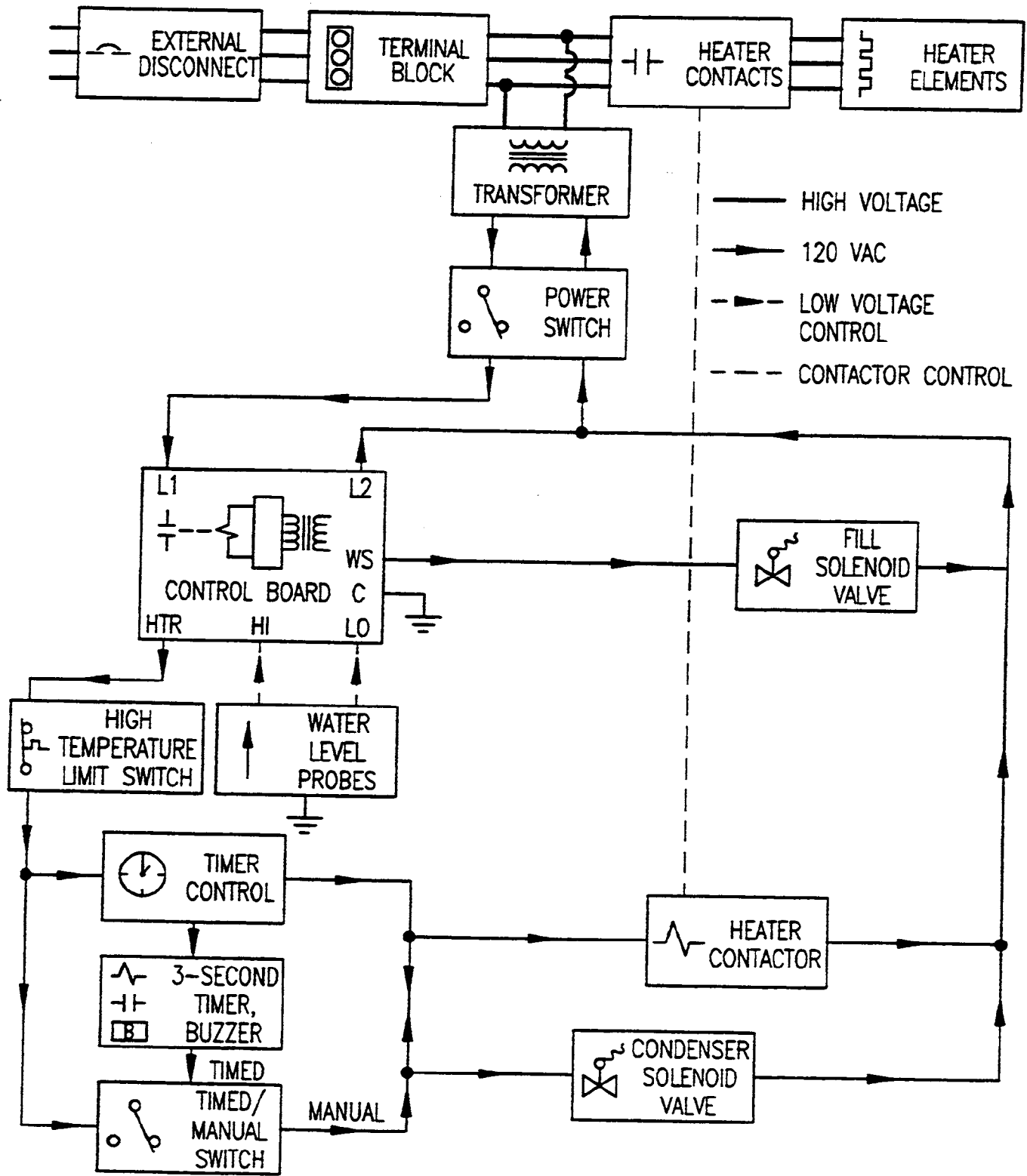

Figure 5-1. Functional Block Diagram

Low Voltage Control Circuit

Power from the 120 VAC secondary of the transformer supplies power to the low-voltage transformer on the control board. Low voltage circuits operate control board relays. In turn, contacts of the relays control 120 VAC power to the Solenoids, Heater Contactor, TIMER Control, TIMED/MANUAL Switch, and the buzzer. The High Level Probe signals the control circuits to maintain proper water level in the steam generator during operation. The Low Level Probe prevents heater operation with a low water level in the generator.

Timer Circuits

The Econocraft comes with a Mechanical Dial Timer which incorporates a separate 3-second Timer And Buzzer to signal the end of the cooking cycle.

CIRCUIT OPERATION

This section describes circuit operation during a typical steaming cycle in MANUAL mode. The circuit operations specific to TIMED mode are also explained. For clarity while reading the description, refer to the Block Diagram, Figure 5-1, and the Electrical Wiring and Schematic Ladder Diagram in Chapter 6, Figures 6-2 and 6-3 respectively.

MANUAL Mode Circuit Operation

Before starting the MANUAL mode steaming cycle, the Econocraft controls are set as follows.

- The main power switch is in the ON position.
- The water supply valves to the unit are open.
- The ON/OFF switch is in the OFF position.
- The TIMED/MANUAL switch is in the MANUAL position.
- The timer is set to 0.

With these control settings, the Econocraft component conditions are as follows.

- The steam generator is empty.
- The Water Fill, Condenser, and Rinse Solenoid Valves are closed.
- The Water Control Unit High Level Probe provides no power through terminals HTR.
- The Water Control Unit Low Level Probe provides no power through terminals WF.
- The high temperature limit switch is closed.

With the TIMED/MANUAL Switch in the MANUAL position, the ON/OFF Switch controls power to the operating circuits. Switching the ON/OFF Switch to the ON position:

1. Energizes the red indicator on the ON/OFF Switch.
2. Provides power to one side of the condenser and fill solenoids, heater contactor, and the TIMED/MANUAL Switch. With this switch in the

MANUAL position, component operation is controlled by the action of the Water Level Control Unit probes, which provide power through terminals HTR and WF as the generator water level fluctuates.

3. Completes the circuit to the Fill and Condenser Solenoids. The fill valve opens to fill the generator tank. The condenser valve opens and supplies water flow to cool the steam-water drainage from the steamer compartment.

After approximately 1.5 minutes, the water level rises to cover the heater elements. The Water Level Control Unit Low Level Probe provides power through HTR to energize the heater contactor. The contactor closes its contacts to supply line power to the heater elements. The unit begins to heat the water in the generator.

4. The water level in the generator continues to rise until the Water Level Control Unit High Level Switch interrupts power to terminal WF. This opens the circuit to the fill solenoid. The fill valve closes and the generator stops filling. After 4 to 5 minutes, the generator produces steam, and the water level in the generator drops. As the water level drops, the Water Level Control Unit High Level Probe provides power through WF. This again re-energizes the fill solenoid. The Water Level Control Unit and the High Level Probe cycle the fill valve to maintain the proper water level for steaming.

The heater remains energized and the unit continuously produces steam until the operator sets the TIMED/MANUAL Switch to TIMED or turns the steamer OFF with the ON/OFF Switch.

- Circuit operations with the TIMED/MANUAL Switch set to TIMED are described in the TIMED Mode Circuit Operations section.
- Circuit operations with the ON/OFF Switch set to OFF are described in the Shutdown Circuit Operations section.

TIMED Mode Circuit Operation

Circuit operations in TIMED mode are similar to those in MANUAL mode. The major difference between the two modes is timed control of the heater contactor and condenser solenoids. With the TIMED/MANUAL Switch in the TIMED position, the timer circuits control power to the heater contactor and condenser solenoid.

When the TIMED/MANUAL Switch is set to the TIMED position, the 3-Second Timer and Buzzer circuits are energized. The Buzzer energizes through the TIMED/MANUAL Switch, timer control contacts L1-T3, and 3-Second Timer. After 3 seconds the 3-Second Timer contacts open, silencing the buzzer.

Use of the Mechanical Dial Timer is explained in Chapter 3. Once a steaming time is set, the timed cooking cycle starts.

1. Turning the timer dial to any position other than 0 closes contacts L1-T1, energizing the condenser solenoid and heater contactor. Timer control contacts L1-T3 open to reset the 3-second Timer.

2. When the time set on the dial elapses, the timer control points to 0. Contacts L1-T1 open to de-energize the heater contactor and condenser solenoid. Timer contacts L1-T3 close to set the 3-Second Timer in operation and cause the Buzzer to sound.

ELECTRICAL CIRCUIT COMPONENTS

This section briefly describes the major Econocraft components and their functions. Refer to the Assembly Drawing, 6-1, for the installation location, assembly details, and parts ordering information for each of these components. The Chapter 6 figure and item number is included for each component described in this section.

When servicing, repairing, or replacing any component, use only Cleveland Range authorized repair parts and procedures. Check that the repair part has the correct part number and is compatible with the power supply rating on the Econocraft Product Identification Plate (Chapter 1). Verify proper wiring connections of newly replaced parts before energizing the unit. Refer to the Electrical Wiring and Schematic Ladder Diagrams on the unit or at the end of Chapter 6. Figures 6-2 and 6-3, respectively.

Terminal Block (62, Figure 6-1)

The Terminal Block provides connection points from the external electrical supply to the steamer. The three-terminal block has connections to the transformer and heater contactor.

Heater Element (4, Figure 6-1)

The heater assembly, located inside the generator near the bottom, comes as a three-coil element. In this text, heater element refers to the complete heater assembly. Heater coil refers to each of the three coils in the assembly. For proper operation of the Econocraft, the rating of the heater element must match the external supply voltage.

Table 5-1. Steam Generator Heater Elements

PART NO.	WATTS	VOLTS	OHMS/PHASE +/-5%
103881	8000	208	16
1038811	8000	230	20

ON/OFF Switch

(40, Figure 6-1)

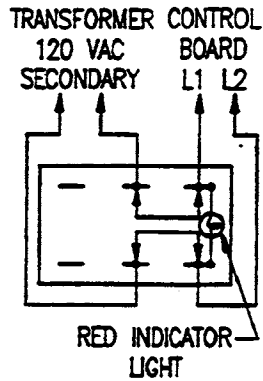

Figure 5-2. ON/OFF Switch

Power from the main transformer connects to the center terminals of the double-pole/double-throw ON/OFF switch. In the ON position, as shown in Figure 5-2, the switch connects the center terminals to the right terminals, as viewed from the terminal side (rear) of the switch.

Setting the ON/OFF Switch to ON supplies power to one side of the Heater Contactor, Condenser Solenoid, and Fill Solenoid.

These components can be activated by control components, the TIMED/MANUAL Switch, Timer Control, High Level Probe, or Low Level Probe.

TIMED/MANUAL Switch

(40, Figure 6-1)

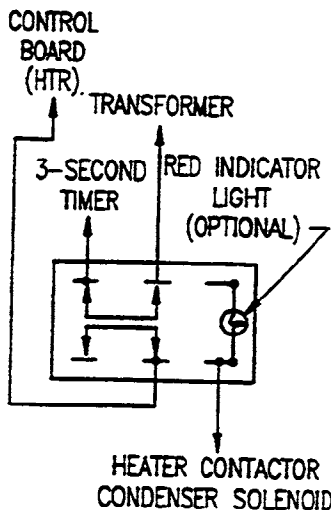

Figure 5-3. TIMED/MANUAL Switch

Setting the ON/OFF Switch to ON supplies power to the center terminals of the TIMED/MANUAL Switch. In the TIMED position as shown in Figure 5-3, the TIMED/MANUAL Switch energizes the Timer Control Circuit. In the MANUAL position, the TIMED/MANUAL Switch energizes the Heater Contactor and Condenser Solenoid, unless either the Water Level Control Unit Low Level Probe or The High Temperature Limit Switch is open.

Fill Solenoid Valve

(64, Figure 6-1)

The Fill Solenoid Valve controls water flow into the steam generator. The valve opens and closes as the water level fluctuates in the generator. During steaming operations, the fill valve cycles approximately two to five times each minute.

- While the water level in the generator is below the upper limit, the high level probe provides power. This energizes the solenoid, which opens the valve.
- When the water level in the generator reaches the upper limit, the high level probe interrupts power. This de-energizes the solenoid, which closes the valve.

The valve operates at a maximum water pressure of 60 psi. Higher pressures cause unnecessary valve wear and require frequent valve replacement. If necessary, install a pressure regulator set at 50 psi.

Condenser Solenoid Valve

(64, Figure 6-1)

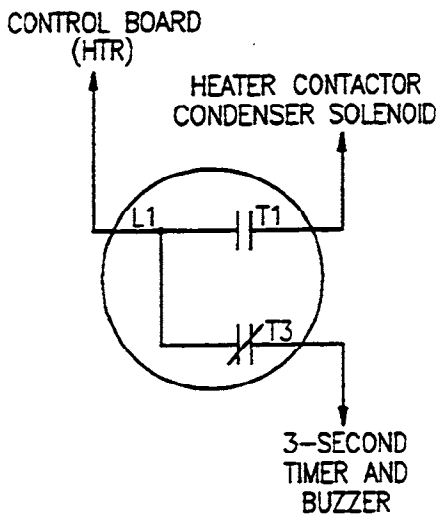

Figure 5-4. Mechanical Dial Timer

The Condenser Solenoid Valve controls cold water flow to the condenser tee at the bottom of the generator. The valve injects cold water into the condenser to cool the vapor and fluid draining from the steamer. This reduces pressure in the compartment drain. Low pressure in the drain maintains optimum performance of the steamer. With a hot or warm water supply connected to the Condenser Solenoid Valve, the condenser WILL NOT function properly, and equipment damage may result.

The Condenser Solenoid Valve energizes when the heater contactor energizes. The condenser solenoid and heater contactor energize through the TIMED/MANUAL Switch.

- During manual operation (TIMED/MANUAL switch set to MANUAL), the condenser solenoid and heater contactor energize directly through the TIMED/MANUAL Switch.
- During timed operation (TIMED/MANUAL Switch set to TIMED), the condenser solenoid and heater contactor energize through the timer control.
- Setting the dial to a time greater than 0 closes contacts L1-T1, energizing the solenoid. When the time elapses and the dial points to 0, timer control contacts L1-T1 open to de-energize the condenser solenoid and open the valve.

Mechanical Timer

(47, Figure 6-1)

The Mechanical Timer controls the Condenser Solenoid and Heater Contactor during timed operation (the TIMED/MANUAL Switch in the TIMED position). In TIMED mode, the timer starts and stops the Econocraft steaming cycle automatically. Operating the dial timer is explained in Chapter 3. After setting the dial, the timed steaming cycle starts. Timer contacts L1-T1 close to energize the condenser solenoid and heater contactor. See Figure 5-4. Contacts L1-T3 open to disable the 3-second timer. When the set time elapses and the dial reads 0, timer contacts L1-T1 open to de-energize the condenser solenoid and heater contactor. Contacts L1-T3 close to supply power to the 3-second Timer and Buzzer.

3-Second Timer and Buzzer

(65, 49, Figure 6-1)

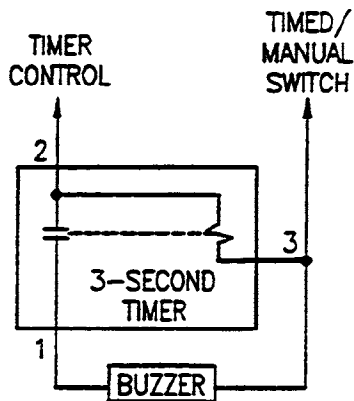

Figure 5-5. 3-Second Timer and Buzzer

The Buzzer provides an audible signal to indicate completion of a timed steaming cycle. With power applied across terminals 2 and 3 (see Figure 5-5), the 3-second Timer contact closes. This allows power flow through terminals 1 and 2 to the Buzzer. After 3 seconds, the 3-Second Timer contact opens and silences the Buzzer. The Buzzer also sounds at the end of MANUAL steaming when the operator sets the TIMED/MANUAL Switch to TIMED.

High Temperature Limit Switch

(19, Figure 6-1)

The High Temperature Limit Switch operates to protect the heater coils from overheating. If the temperature near the heater element reaches 240°F, the switch opens. This interrupts power to the heater contactor to prevent operation of the heater element.

Water Level Control Unit

(23, Figure 6-1)

The Water Level Control Unit monitors the water level in the steam generator, and controls the fill valve and heater circuits accordingly.

Refer to Water Level Control Unit Block Diagram, Figure 5-6. The Water Level Control Unit is a module containing the necessary electronics to decode the signals coming from the two water level probes, the high level sensor and the low level probe. During normal operation the low level probe provides power to the heater contactor and condenser coil through relays in the water level control unit. If a malfunction occurs and the water level decreases below a safe operating level, the lower probe opens the relay internal to the Waterlevel Control Unit to remove power from the heater contactor.

During steaming operations, the high level probe operates the Water Level Control Unit to maintain the proper water level in the steam generator.

- While the water level is below the upper probe point, the Water Level Control Unit provides power to the Fill Solenoid Valve which fills the generator.
- When the water level reaches the high level probe, the Water Level Control Unit interrupts power to the WF terminals. This shuts the fill valve and stops water flow into the generator.

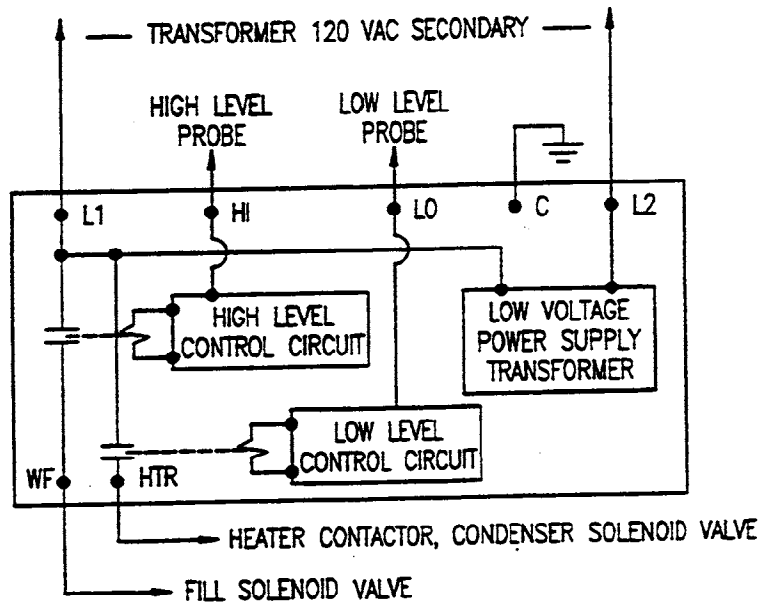

Figure 5-6. Water Level Control Unit
Block Diagram

Water Level Probe Assembly (14, Figure 6-1)

The probe assembly contains two water level probes. Both probes operate as part of low voltage control board circuits; refer to Figure 5-6.

Low Level Probe

The Low Level (long) Probe works to prevent heater operation with low water level in the generator. This assures that sufficient water covers the heater elements for safe operation. Operation of the heaters with a low water level or no water in the generator causes burnout of the elements.

The Low Level Probe controls operation of the Low Level Control Circuit. When the water level rises above the bottom tip of the Low Level Probe, the circuit relay closes a contact to supply power through control board terminal L1 to terminal HTR. This provides power for the Heater Contactor and Condenser Solenoid when called for by operation of the TIMER control or TIMED/MANUAL Switch.

Normally, the high level fill circuit maintains level above the Low Level Probe tip. The low level circuit normally functions only during an empty generator startup. Typically, startup takes about 45 seconds for the water level to rise above the probe tip and the heaters to energize.

High Level Probe

The High Level (short) Probe controls operation of the High Water Level Control Circuit. This circuit maintains proper operating level in the generator by cycling the Fill Solenoid Valve.

With the level in the generator below the bottom tip of the High Level Probe, the circuit relay closes the contact to route power through control board contact L1 to terminal WF. This action energizes the Fill Solenoid Valve to allow water to enter the generator. When the level covers the bottom tip of the High Level Probe, the control relay opens the contact to remove power at terminal WF. This de-energizes the Fill Solenoid Valve and the generator stops filling. When the water level drops below the tip of the probe continuously for five or more seconds, the circuit cycles the fill valve open to supply water to the generator. The 5-second delay prevents excessive cycling of the fill valve during operation.

COMPONENT TESTING GUIDE INTRODUCTION

The component testing guide helps qualified service personnel test Econocraft components and determine which are operating properly. By first identifying the systems that are operable, service personnel can quickly isolate malfunctions without unnecessary testing and component replacement. The guide has two sections:

- Fundamental Component Testing
- Component Test Procedures

If components must be replaced, use only Cleveland Range authorized replacement parts to maintain complete warranty coverage.

Nominal Voltage

Throughout the testing guide and instructions, the text uses 240 VAC as the typical or nominal voltage. Refer to the Product Identification Plate (Chapter 1), and determine the voltage characteristics of the Econocraft being serviced (i.e. 208 or 240 VAC). Use this voltage in place of the nominal voltage cited in the text.

FUNDAMENTAL COMPONENT TESTING

This section summarizes the fundamentals of testing Econocraft components. An occasional review of this material is advisable, even for the most experienced service representative. Keep the principles of this section in mind while testing and servicing the Econocraft and its components. Although these tests can be performed independently, the Initial Test Procedures should be performed to first identify the most probable causes of trouble. This systematic approach avoids random unnecessary component testing.

Visual Check

Before starting any detailed troubleshooting, visually check the unit for obvious damage or other faults. Often malfunctions can quickly be isolated by inspecting for water leaks, loose connections, and burned or melted wiring insulation.

Connection Points and Wiring

Any component malfunction can result from loose connections or open wiring. Be sure to check for these conditions before replacing any component.

Discoloration of wire insulation near connection points usually indicates loose connections. Current flow through loose connections causes oxidation and increased resistance of the connection. The resistance can increase to a point where the connection can no longer dissipate the heat generated and the terminal burns.

High-current connections, such as at the Terminal Block and contactor terminals, are particularly susceptible to damage when loose. Using wire that is too small in diameter also yields the same results. Be sure that any wiring meets the amperage requirements of the circuit.

All connections should have no resistance and measure 0 VAC across them. Any voltage reading greater than 0 VAC across a connection indicates a faulty connection and must be corrected.

The Econocraft uses some pressure type connections. Be sure to tighten screw and nut connections securely and that threads are not cross threaded. Special care must be used to secure the high voltage contactor connections. If loose, these high current connections will burn or explode and cause extensive damage.

Solenoid Valves

All solenoid valves in the Econocraft energize to open the valves. The solenoid energizes at a nominal 120 VAC. Power applied to a properly operating solenoid causes an audible click sound. While energized, the solenoid hums at low volume. The click sound usually indicates a properly operating valve. If water does not flow with the valve energized, check for a solenoid valve stuck closed, clogged inlet or outlet in the valve body or in the plumbing external to the valve. Check that external supply valves are open.

If water flows through the valve when the solenoid is de-energized, check for a stuck open valve, worn valve seat, or foreign material blocking valve closure.

When testing or replacing any solenoid valve, check the valve for correct flow direction. Markings on the valve body indicate IN for the inlet, OUT for the outlet, or both. Some valves may use an arrow to indicate the proper flow direction. Valves installed backwards will not work correctly.

Energized solenoids generate a magnetic field that can be detected with a steel screw driver. Note that some stainless steels, brass, and aluminum alloys are not magnetic and will not sense the magnetic field.

Low voltage, below about 90 VAC, will cause the solenoid to hum loudly or chatter. Check transformer secondary for 120 VAC nominal. Check for loose connections.

The resistance of a good solenoid coil measures about 600 ohms.

The Econocraft solenoid valves operate at a maximum pressure of 60 psi. Higher pressure causes unnecessary valve wear and requires frequent valve replacement. If necessary, install a pressure regulator set at 50 psi.

Timers

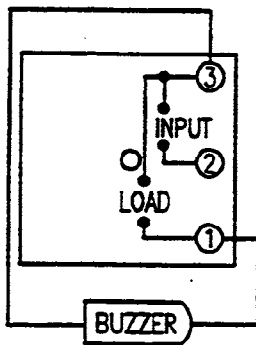

Figure 5-7. 3-Second Timer and Buzzer

If the Mechanical Dial Timer fails, the Econocraft can usually be operated in MANUAL mode (TIMED/MANUAL Switch set to MANUAL). This allows continued operation while waiting for a replacement timer.

The 3-Second Timer operates as follows. When 120 VAC is applied across terminals 2-3 (INPUT), the timer circuits provide 120 VAC across terminals 1-3 (LOAD). When the time elapses (3 seconds), the timer sets the LOAD terminals to 0 VAC.

A timer contains electronic components which work like a relay and contact. Refer to Figure 5-7. When the switch closes, the timing circuit (shown as a relay and contact) energizes. The timing circuit closes its contact to energize the solenoid. When the delay time of the timer elapses (3 seconds), the timing circuit opens the contact and the solenoid deenergizes.

A load must be connected to the LOAD terminals of the timer during testing. Use a spare solenoid or buzzer as the test load. Without a load connected to the LOAD terminals, the voltage across the LOAD terminals will read 120 VAC when the timer energizes and will remain at 120 VAC indefinitely.

Because the LOAD terminals remain energized only for a short time, connect the voltmeter across the LOAD terminals before energizing the timer and leave it connected during the test. Watch for the LOAD voltage to read 120 VAC when the timer energizes and 0 VAC at the end of the proper delay (3 seconds).

Thermostatic Snap Switches

The Thermostatic Snap Switch, is a high temperature limit switch that protects the heater elements. This switch can be tested by voltage or resistance measurements. Closed switches should always measure 0 ohms. Resistance of any open switches should always measure infinity.

Terminal Block

Refer to Connection Points and Wiring section on page 47, and inspect the Terminal Block and its connection leads accordingly.

Heater Element

In this text, heater element refers to the complete assembly. The heater element contains three coils. Wire markings identify each coil as follows:

- Coil 1 connects to leads 1L1 and 1L2
- Coil 2 connects to leads 2L1 and 2L2
- Coil 3 connects to leads 3L1 and 3L2

Resistance Measurements

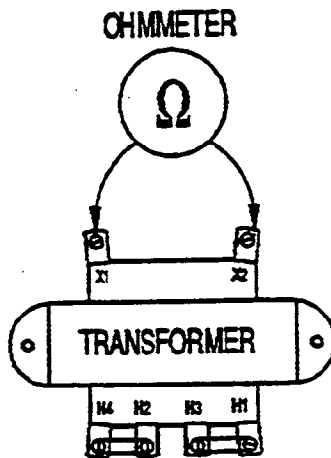

Figure 5-8. Typical Ohmmeter Connection

De-energize all circuits before connecting any resistance measuring device such as an ohmmeter. Notice that the ON/OFF switch set to OFF does not remove power from all 120 VAC circuits. Turn power OFF at the main power switch. Measuring resistance with power applied may damage your meter.

Before measuring resistance of any component, isolate the component by disconnecting one or both circuit leads from the component. This will prevent a false reading caused by circuit paths through other components in parallel with the one being measured. Remember to replace the component leads after making the measurement. Figure 5-8 shows a typical ohmmeter connection.

Insulation Resistance Measurements

When measuring the insulation resistance of heater coils to ground, use a 500 or 1000 volt megohm meter (megger), if available. Ordinary multimeters do not always detect insulation breakdown because they use low voltage batteries to supply power for resistance measurements. True insulation resistance requires a high voltage megger reading. Multimeters can be used only to make a quick check for gross insulation breakdowns. Set the multimeter to the highest scale and then zero the meter using the zero adjust. An insulation resistance of less than one megohm usually indicates poor insulation. A very low resistance (less than 1,000 ohms) indicates broken insulation.

Voltage Measurements

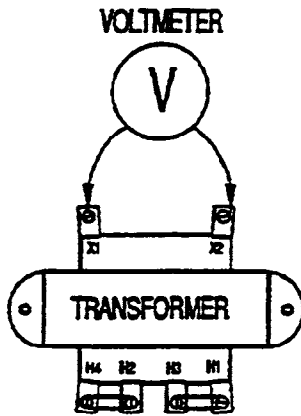

Figure 5-9. Typical Voltmeter Connection

Voltage measurements require care. Always test your meter on a known voltage source to ensure correct meter operation. Any 120 or 220 VAC outlet provides a convenient voltage source. Circuits that appear dead because a faulty meter indicated 0 volts have resulted in many hair-raising (and deadly) experiences for even seasoned troubleshooters.

When checking voltages, set your meter to the proper scale. For example, if checking 120 VAC circuits, use a higher voltage meter scale such as 250 or 500 VAC. Use AC scales for AC circuits. DC meter scale readings on AC circuits yield incorrect results.

If your voltmeter does not have the exact scale as stated in any component test, use any convenient scale higher than the expected voltage. For example, if the test calls for setting the meter on the 250 VAC scale for an expected reading of 120 VAC, and your meter does not have a 250 VAC scale, use the 500 VAC scale. Figure 5-9 shows a typical voltmeter connection.

COMPONENT TEST PROCEDURES

The following procedures are detailed tests to determine whether or not particular Econocraft components are operable. Before starting the individual Component Test Procedures, refer to Chapter 2 and complete the Final Setup and Checkout Procedures. During these procedures, observe component performance. Then perform the appropriate component tests to check specific parts.

Initial conditions for all testing.

- All exterior drains and drain valves are open.
- All exterior water supply valves are open.
- The main power switch is in the on position.
- The access cover is removed.

CT:1 ON/OFF Switch

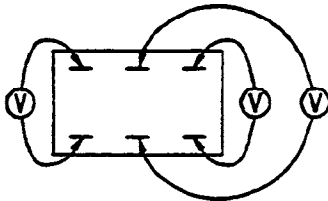

Figure 5-10. ON/OFF Switch

1. Set the voltmeter to the 250 VAC scale.
2. Set the ON/OFF Switch to the ON position.
 - If the red indicator lights, proceed to step 3.
 - If the red indicator does not light, proceed to step 4.
3. Set the ON/OFF Switch to the OFF position. Refer to Figure 5-10 and check for 120 VAC across the left terminals of the ON/OFF Switch.
 - If the meter reads 120 VAC, the ON/OFF Switch is good. End this procedure here.
 - If the meter does not read 120 VAC, replace the ON/OFF Switch and end this procedure here.
4. Refer to Figure 5-10 and check for 120 VAC across the center terminals of the ON/OFF Switch.

- If the meter reads 120 VAC, continue this test with step 5.
 - If the meter does not read 120 VAC, the fault is not in the switch.
 - a. Test transformer.
 - b. Check the wiring and connections between the transformer terminals X1-X2 and the ON/OFF Switch.
5. Refer to Figure 5-10 and check for 120 VAC across the right terminals of the ON/OFF Switch.
 - If the meter reads 120 VAC, continue this procedure with step 6.
 - If the meter does not read 120 VAC, replace the ON/OFF Switch and end this procedure here.
 6. Set the ON/OFF Switch to the OFF position. Refer to Figure 5-10, and check for 120 VAC across the left terminals of the ON/OFF Switch.
 - If the meter reads 120 VAC, the indicator light is burned out. Replace ON/OFF Switch when convenient.
 - If the meter does not read 120 VAC, replace the ON/OFF Switch.

CT:2 Fill Solenoid Valve

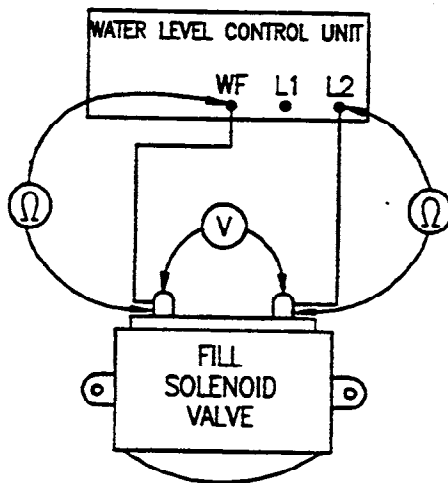

Figure 5-11. Fill Solenoid Valve

1. Set the voltmeter to the 250 VAC scale.
2. Set the ON/OFF Switch to the ON position and observe the red indicator light.
 - If the indicator does not light, test the ON/OFF Switch before doing this procedure.
 - If the indicator lights, continue this test with step 3.
3. Observe the water level in the generator assembly.
 - If valve opens, fills the generator to the high level and stops, the valve is operating properly. End this procedure here.
 - If valve does not open to let water flow into the generator, continue this procedure with step 4.
 - If valve fills the generator but does not stop at the high level switch, continue this procedure with step 5.
4. Refer to Figure 5-11 and check for 120 VAC across the solenoid terminals.
 - If the meter reads 120 VAC, replace the Fill Solenoid Valve.
 - If the meter does not read 120 VAC, the fault is not in the Fill Solenoid Valve.
 - a. Refer to Figure 5-11 and check the wiring between the Fill Solenoid Valve and the Water Level Control Unit
 - b. Test the Water Level Control Unit and the High Level Probe and associated wiring as described in CT:9 and CT:12 respectively.
 - c. Test the Transformer.

5. Disable the 3-Second Timer by removing the wire from the 3-Second Timer terminal 2. Set the ON/OFF Switch to the OFF position.
 - If overfilling continues, the fill valve has failed or is stuck open. Reconnect the wire to the 3-second Timer terminal 2. Replace the Fill Solenoid Valve. End this procedure here.
 - If the valve fills the generator to the high level and stops, the valve is operating properly.
 - a. Reconnect the wire to the 3-Second Timer terminal 2.
 - b. Set the ON/OFF Switch to the ON position.
 - c. Test the Water Level Control Uni, the High Level Probe and associated wiring as described in CT:9 and CT:12, respectively.

CT:3 Condenser Solenoid Valve

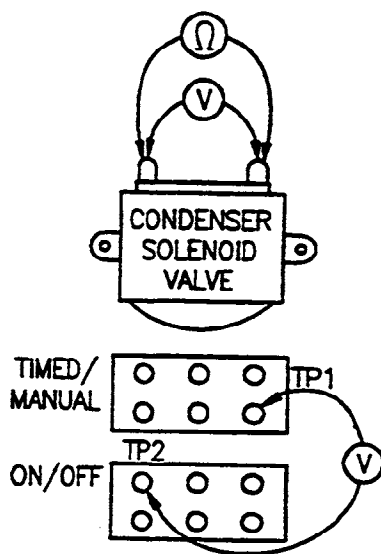

Figure 5-12. Condenser Solenoid Valve

1. Set the voltmeter to the 250V scale.
2. Set the ON/OFF Switch to the ON position.
3. Set the TIMED/MANUAL Switch to the MANUAL position.
4. Check for outflow at the drain opening.
 - If water flows from the drain, the Condenser Valve is good. End this procedure here.
 - If no water flows from the drain, the fault may not be the drain solenoid. Check for clogged drain plumbing. Continue this procedure with step 5.
5. Refer to Figure 5-12, and connect the voltmeter leads to test point 1 and test point 2. With these connections, check for 0 VAC across the drain solenoid.
 - If the meter reads 0 VAC across the drain solenoid, and the drain is not draining water, check for clogged drain plumbing.
6. Set the voltmeter to the Ohms scale.
7. Check the coil resistance across the condenser solenoid terminals.
 - a. Compare this resistance with the ohms listed in Table 5-1 on page 41. Remove wiring connections from solenoid valve(s) at terminal strip before making measurements. Separate wires at terminal strip and make resistance measurements individually.
 - b. If the meter reads greater than +/- 5% resistance across the solenoid terminals, the solenoid valve is faulty. Replace the Condenser Solenoid Valve.
8. Refer to Heater Contactor Test (Figure 5-16) and check for 120 VAC across the coil terminals of the heater contactor.
 - If the meter does not read 120 VAC across the coil terminals of the heater contactor, continue this procedure with step 8.

- If the meter reads 120 VAC across the coil terminals of the heater contactor, the condenser solenoid wiring is faulty. Check the condenser solenoid wiring for continuity and secure connections. Replace or repair faulty wiring and connections.
9. Check for 120 VAC from the TIMED/MANUAL Switch TP1 connection to the ON/OFF Switch TP2 wire connection.
 - If the meter does not read 120 VAC between these TIMED/MANUAL and ON/OFF Switch wire connections, the fault is not in the Condenser Solenoid Valve. Test the TIMED/MANUAL Switch.
 - If the meter reads 120 VAC between these TIMED/MANUAL and ON/OFF Switch wire connections, the condenser solenoid wiring is faulty. Check the wires leading from the condenser solenoid for continuity, and secure connections. Replace or repair faulty wiring and connections.

CT:4 TIMED/MANUAL Switch

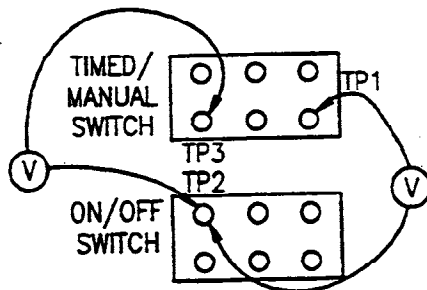
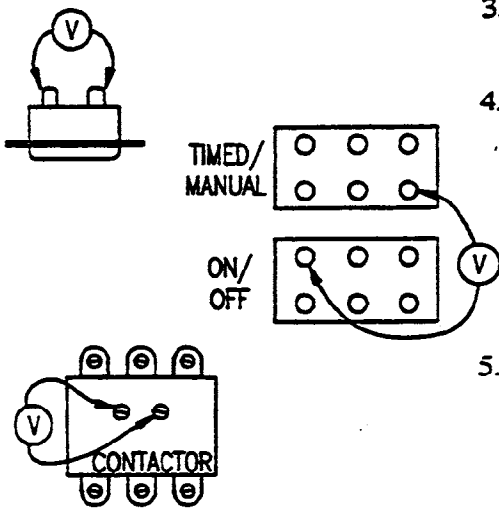

Figure 5-13. TIMED/MANUAL Switch

1. Set the voltmeter to the 250 VAC scale.
2. Set the ON/OFF Switch to the ON position.
3. Set the TIMED/MANUAL Switch to the TIMED position.
4. Zero and clear the timer.
5. Set the TIMED/MANUAL Switch to MANUAL, and check that the condenser solenoid and heater contactor energize.
 - If both the condenser solenoid and heater contactor energize, continue this procedure with step 6.
 - If both the condenser solenoid and heater contactor do not energize, continue this procedure with step 7.
6. Set the TIMED/MANUAL Switch to the TIMED position. Refer to Figure 5-13. Check for 120 VAC from the TIMED/MANUAL Switch TP1 connection to the ON/OFF Switch TP2 connection.
 - If the meter does not read 120 VAC between these TIMED/MANUAL and ON/OFF Switch wire connections, replace the TIMED/MANUAL Switch.
 - If the meter reads 120 VAC between these TIMED/MANUAL and ON/OFF Switch wire connections, the fault is not in the TIMED/MANUAL Switch. Test the timer and timer wiring.
7. Refer to Figure 5-13. Check for 120 VAC from the TIMED/MANUAL Switch TP3 to the ON/OFF Switch TP2.
 - If the meter reads 120 VAC between these TIMED/MANUAL and ON/OFF Switch wire connections, the fault is not in the TIMED/MANUAL Switch. Check wiring to condenser solenoid and heater contactor.
 - If the meter does not read 120 VAC between these TIMED/MANUAL and ON/OFF Switch wire connections, either the TIMED/MANUAL Switch or the wiring connected to it is faulty.

- a. Check the TIMED/MANUAL Switch wiring for continuity, and secure connections. Replace or repair faulty wiring and connections.
- b. If the wiring and connections are good, the TIMED/MANUAL Switch is faulty. Replace the TIMED/MANUAL Switch.

CT:5 High Temperature Limit Switch



1. Set the voltmeter to the 250 VAC scale.
2. Set the ON/OFF Switch to the ON position.
3. Before proceeding to step 4, wait until water fills the generator to normal operating level.
4. Set TIMED/MANUAL Switch to MANUAL. Check that the heater contactor energizes: 120 VAC across the heater contactor coil. Figure 5-14.
 - If the meter reads 120 VAC, the High Temperature Limit Switch is good. End this procedure here.
 - If the meter does not read 120 VAC, continue this procedure with step 5.
5. Refer to Figure 5-14 and check for 120 VAC across the High Temperature Limit Switch terminals.
 - If the meter reads 120 VAC, replace the High Temperature Limit Switch.
 - If the meter reads 0 VAC, continue this procedure with step 6.
6. Refer to Figure 5-14 and check for 120 VAC from the TIMED/MANUAL Switch orange wire connection to the ON/OFF Switch white/black wire connection.
 - If the meter does not read 120 VAC between these test points, test the TIMED/MANUAL Switch.
 - If the meter reads 120 VAC between these test points, the fault is not in the High Temperature Limit Switch.
 - a. Check the wires to the High Temperature Limit Switch, Water Level Control Unit, and the contactor for continuity, and secure connections. Replace or repair faulty wiring and connections.
 - b. Test low limit probe.
 - c. Test the contactor for an open coil.

Figure 5-14. High Temperature Limit Switch

CT:6 Mechanical Dial Timer

Figure 5-15. Mechanical Dial Timer

1. Set the voltmeter to the 250 VAC scale.
2. Set the ON/OFF Switch to the ON position.
4. Set the TIMED/MANUAL Switch to the MANUAL position. Operate the Econocraft for about 10 minutes, or until it is steaming continuously.
5. Set the TIMED/MANUAL Switch to the TIMED position, and zero the timer. Steam generation will stop. When the water level in the float cylinder stabilizes at the high level probe, perform step 6.
6. Set the timer dial to 10 minutes. Compare the actual steamer operation to that described in steps 8 through 10 of the Operating Tests - Mechanical Dial Timer Control Panel section of Chapter 2.
 - If actual operation matches the described operation, continue this procedure with step 7.
 - The timer fails the 10-minute test if actual operation does not match the described operation. Replace the timer and end the procedure here.

Typical failures are:

- a. Steaming continues after the preset time on the dial elapses to 0.
 - b. The dial time is fast or slow compared to real time. (10 minutes on the dial elapses after 5 or 20 minutes real time.)
 - c. The timer dial does not complete the countdown to zero.
7. Set the timer dial to 0. Refer to Figure 5-15. Check for 120 VAC across timer terminals L1-T1, and 0 VAC across timer terminals L1-T3.
 - If the meter reads 120 VAC across L1-T1 and 0 VAC across L1-T3, continue this procedure with step 8.
 - If the meter reads 0 VAC across L1-T1, the contacts L1-T1 are shorted within the timer. Replace the Mechanical Dial Timer.
 - If the meter reads 120 VAC across L1-T3, the contacts L1-T3 are open within the timer. Replace the dial timer.
 8. Set the timer dial to 10 minutes. Refer to Figure 5-15. Check for 0 VAC across timer terminals L1-T1, and 120 VAC across timer terminals L1-T3.
 - If the meter reads 0 VAC across L1-T1 and 120 VAC across L1-T3, the Mechanical Dial Timer is good. End this procedure here.
 - If the meter reads 120 VAC across L1-T1, replace the Mechanical Dial Timer.
 - If the meter reads 0 VAC across L1-T3, replace the Mechanical Dial Timer.

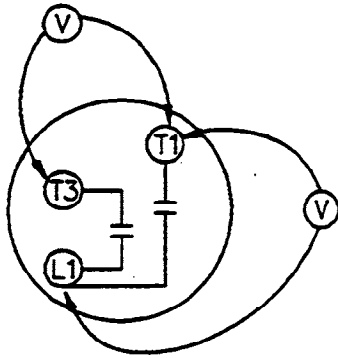
CT:7 Heater Contactor

1. Set the voltmeter to the 250 VAC scale.
2. Set the ON/OFF Switch to the ON position.

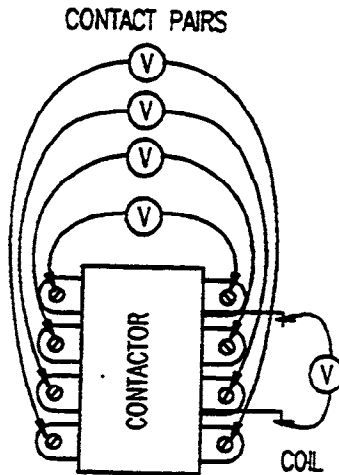

Figure 5-16. Heater Contactor

3. Set the TIMED/MANUAL Switch to the MANUAL position. Operate the Econocraft for about 10 minutes, or until it is steaming continuously, and the water in the float cylinder is at operating level.
4. Refer to Figure 5-16, and check for 120 VAC across the heater contactor coil terminals.
 - If the meter reads 120 VAC across the test points, and the heaters are heating, the heater contactor is good. End this procedure here.
 - If the meter reads 120 VAC across the test points, and the heaters are not heating, continue this procedure with step 5.
 - If the meter reads 0 VAC or a low voltage across the test points, the fault is not in the heater contactor.
 - a. Check the wires connected to the heater contactor coil for continuity and secure connections. Replace or repair faulty wiring and connections.
 - b. Test the high temperature limit switch as described in CT:5.
 - c. Test the low level probe as described in CT:11.
 - d. Test the TIMED/MANUAL Switch as described in CT:4.
5. Set the voltmeter to the 500 VAC scale. Refer to Figure 5-16, and check the voltage across the contact pairs.
 - If the meter reads 230 VAC across one or more contact pairs, replace the heater contactor.
 - If the meter reads 0 VAC across all contact pairs, the fault is not in the heater contactor.
 - a. Check the wires and connections from the contact pairs to the heater elements for continuity and secure connections. Replace or repair faulty wiring and connections.
 - b. Check the wires and connections from the terminal block to the contacts for continuity and secure connections. Replace or repair faulty wiring and connections.
 - c. Test heater elements as described in CT:8.

CT:8 Heater Elements

1. Set the voltmeter to the 500 VAC scale.
2. Set the ON/OFF Switch to the ON position.
3. Set the TIMED/MANUAL Switch to the MANUAL position. Operate the Econocraft for about 10 minutes, or until it is steaming continuously, and the water in the float cylinder is at operating level.
4. Refer to Figure 5-17, and check for 230 VAC across all three heater coils.
 - If the meter reads 230 VAC across all three heater coils, continue this procedure with step 5.

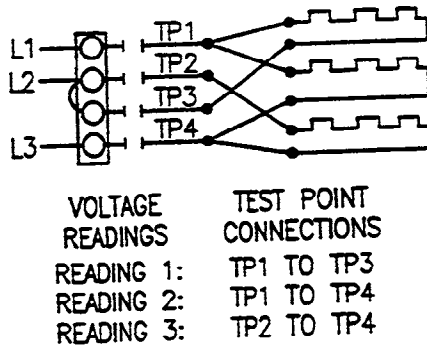

Figure 5-17A. Heater Elements Voltage Readings

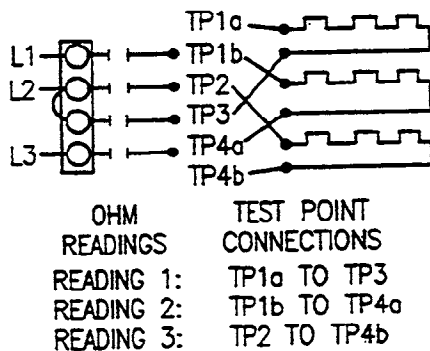

Figure 5-17B. Heater Elements Ohm Readings

- If the meter does not read 230 VAC across one or more of the heater coils, the fault is not in the heater elements.
 - a. Check the wires to the heater elements for continuity and secure connections. Replace or repair faulty wiring and connections.
 - b. Check for 230 VAC in each phase at the main power supply switch.
 - c. Test the heater contactor as described in CT:8.
 - d. Check the resistance of heater and dryer elements as described in steps 5 and 6 of this procedure.
- 5. Prepare the Econocraft components for testing the heater and dryer element resistance as described below. Perform the resistance tests as described in step 6.
 - a. Set both the ON/OFF Switch and the main power switch to the OFF position.
 - b. Refer to Figure 6-3. Schematic Ladder Diagram and disconnect all heater and dryer leads from element terminals of contactor.
 - c. Set both the ON/OFF Switch and the main power switch to the ON position. Allow water to fill the generator to operating level.
 - d. Zero adjust the ohmmeter at the lowest scale. Continue this procedure with step 6.
- 6. Refer to Figure 5-17, and check the resistance of each heater element. Compare the meter readings with the values listed in Table 5-1.
 - If any of the heater coils do not have the resistance specified in Table 5-1, replace the element.
 - If all three heater coils have the resistance specified in Table 5-1, continue this procedure with step 7.
- 7. Prepare the Econocraft components for testing the heater and dryer element insulation resistance as described below. Perform the insulation resistance tests as described in step 8.
 - a. Set megohm meter (megger) at 500 or 1000 volts. If a megger is not available, zero adjust an ohmmeter on the highest scale.
 - b. Check that the water in the generator is at operating level.
 - c. Continue this procedure with step 8.
- 8. Refer to Figure 5-17, and check the insulation resistance of each heater and dryer element lead to ground. Use the element assembly stud as ground.
 - If the resistance is infinite (greater than 1 megohm) on all coils of the heater element, the heater element is good. Reconnect heater leads. Make sure the connections are tight.

- If the resistance is low (less than 1 megohm) on all coils of the heater element, replace the heater element. Connect the heater leads. Make sure the connections are tight.

CT:9 Water Level Control Unit

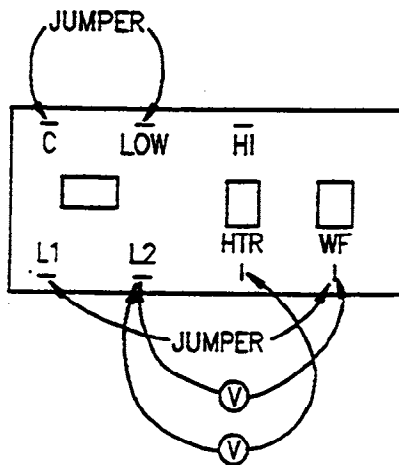

Figure 5-18. Water Level Control Unit

1. Set the voltmeter to the 250 VAC scale.
2. Set the TIMED/MANUAL Switch to the MANUAL position.
3. Set the ON/OFF Switch to the ON position. If the generator fills to the proper level and the unit starts steaming, the Control Board is OK. End this procedure here. If the unit does not steam, continue this procedure with step 4. If unit does not fill to proper level continue this procedure with step 7. If the generator overfills, continue this procedure with step 10.
4. Refer to Figure 5-18 and connect the voltmeter across terminals HTR-L2. If the meter reads 0VAC across terminals HTR-L2, continue this procedure with step 5. If the meter reads 120VAC across terminals HTR-L2, perform the following steps.
 - Test TIMED/MANUAL Switch as described in CT:4.
 - Test heater contactor as described in CT:7.
 - Test heater elements as described in CT:8.
 - Test High Temperature Limit Switch as described in CT:5.
5. Refer to Figure 5-18 and jumper Control Board terminal LOW to ground and check voltage across terminals HTR-L2. If the meter reads 0VAC across terminals HTR-L2, continue this procedure with step 6. If the meter reads 120 VAC, the Control Board is OK.
 - Remove jumper.
 - Test low level probe as described in CT:11.
6. Replace Control Board.
 - If the meter does not read 120 VAC, the fault is not in the float assembly.
 - a. Test the ON/OFF Switch.
 - b. Test the TIMED/MANUAL Switch.
 - c. Test the contactor for an open coil.
 - If the meter reads 120 VAC, either the float or the float wiring circuit is faulty.
 - a. Check the wiring between the TIMED/MANUAL Switch, the float, the contactor, and the ON/OFF Switch for continuity, and secure connections. Replace or repair faulty wiring and connections.
 - b. If the wiring and connections are good, the float assembly is faulty. Replace the float assembly.

7. Tank does not fill.
 - Refer to Figure 5-18 and check voltage across Control Board terminals WF-L2. If the meter reads 0VAC across terminals WF-L2, continue this procedure with step 8. If the meter reads 120VAC across terminals WF-L2, Control Board is OK.
 - Test Fill Solenoid Valve as described in CT:2.
 - Check wires and connections to Fill Solenoid Valve.
8. Refer to Figure 5-18 and remove HI connection (white/yellow wire) from Control Board. If tank does not fill, continue this procedure with step 9. If tank fills, Control Board is OK.
9. Refer to Figure 5-18 and jumper Control Board terminals WF-L1
 - If the tank fills, replace the Control Board.
10. Refer to Figure 5-18 and jumper Control Board terminal HI to ground. If generator keeps filling, remove WF connection (white/blue wire) from control board.
 - If generator stops filling, replace control board.
 - If generator keeps filling, test fill valve for stuck open condition.
11. If generator stops filling:
 - Remove jumper.
 - Test high level probe as described in CT:12.

CT:10 3-Second Timer and Buzzer

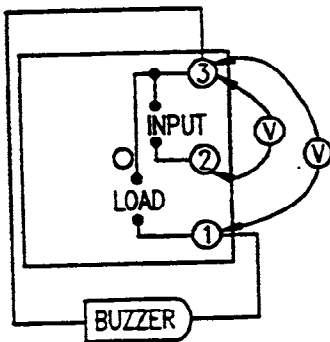

Figure 5-19. 3-Second Timer and Buzzer

1. Set the voltmeter to the 250 VAC scale.
2. Set the ON/OFF Switch to the ON position.
3. Set the TIMED/MANUAL Switch to the MANUAL position.
4. Refer to Figure 5-19, and connect the voltmeter leads across timer terminals 1-3 (LOAD).
5. Set the TIMED/MANUAL Switch to TIMED, and check for 120 VAC across timer terminals 1-3 (LOAD).
 - If the meter reads 120 VAC across the test points, continue this procedure with step 7.
 - If the meter does not read 120 VAC across the test points, continue this procedure with step 6.
6. Refer to Figure 5-19, and connect the voltmeter leads across timer terminals 2-3 (INPUT). Check for 120 VAC across the test points.
 - If the meter reads 120 VAC across the test points, replace the 3-second Timer.
 - If the meter does not read 120 VAC across the test points, check the wire from the 3-second Timer terminal 3 to relay TIMED/MANUAL

Switch, and the wire from the 3-Second Timer to the Mechanical Dial Timer for continuity and secure connections. Replace or repair faulty wiring and connections.

7. Check the meter readings and Buzzer as the 3-Second Timer counts down.
 - If after 3 seconds, the 120 VAC meter reading drops to 0 VAC and the Buzzer stops sounding, the 3-Second Timer and Buzzer are working properly. End this procedure here.
 - If the voltmeter reading remains at 120 VAC and the Buzzer continues to sound for more than 3 seconds, replace the 3-second Timer.
 - If after 3 seconds, the 120 VAC meter reading drops to 0 VAC but the Buzzer does not sound, either the Buzzer wiring or the Buzzer are faulty.
 - a. Check the black wires from the 3-Second Timer to the Buzzer for continuity and secure connections. Replace or repair faulty wiring and connections.
 - b. If the wiring and connections are good, replace the 3-Second Timer.

CT:11 Low Level Probe

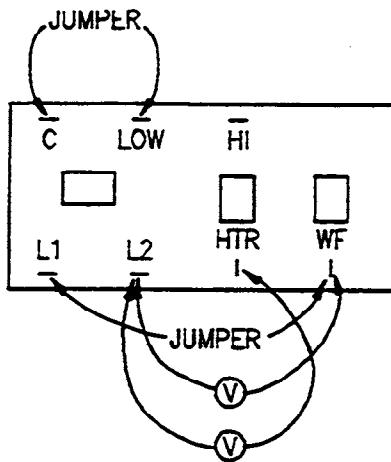

Figure 5-20. Water Level Control Unit

1. Check that the main power switch is in the ON position.
2. Set the voltmeter to the 250 VAC scale.
3. Set the TIMED/MANUAL Switch to MANUAL
4. Water in the generator covers the bottom tip of the Low Level Probe.
5. If the unit steams:
 - Refer to Figure 5-20 and remove LOW connection (white/orange wire) at Control Board.
 - If the unit stops steaming, the low level probe is OK. Replace LOW connection wire.
6. Refer to Figure 5-20 and if the unit does not steam, jumper Control Board terminal LOW to ground.
 - If the unit steams at this point, remove jumper and replace probe assembly.
 - If the unit does not steam, test the heater contactor and/or heater elements, and/or TIMED/MANUAL Switch, and/or High Temperature Limit Switch, and/or Control Board as described in their respective component test procedure.

CT:12 High Level Probe

1. Check that the main power switch is in the ON position.
2. Set the voltmeter to the 250 VAC scale.
3. Set the TIMED/MANUAL Switch to MANUAL
4. If water in the generator fills to the proper level, High Level Probe is OK.

5. If generator does not fill:
 - Remove HI connection (white/yellow wire) at Control Board. See Figure 5-20.
 - If the unit fills, replace probe assembly.
6. Refer to Figure 5-20 and if the generator does not fill, replace Control Board terminal HI wire.
 - Test Control Board
 - Test Fill Solenoid Valve.
7. If the generator overfills.
 - Refer to Figure 5-20 and jumper Control Board terminal HI to ground.
8. If the generator stops filling, replace Probe Assembly
9. If the generator keeps filling:
 - Test Control Board as described in CT:9.
 - Test Fill Valve for stuck open condition.

CT:13 Transformer

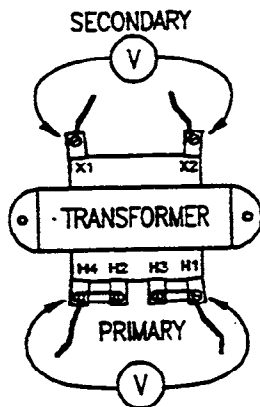

Figure 5-21. Transformer

1. Check that the main power switch is in the ON position.
2. Set the voltmeter to the 250 VAC scale.
3. Refer to Figure 5-21, and check for 120 VAC across transformer primary terminals X1-X2.
 - If the meter reads 120 VAC, the transformer is good. End this procedure here.
 - If the meter reads no or low voltage across terminals X1-X2, continue this procedure with step 4.
4. Set the voltmeter to the 500 VAC scale.
5. Check power at main power switch.
 - If the meter does not read 240 VAC at the main power switch:
 - a. Verify that the main power switch is in the ON position.
 - b. Check breakers or fuses in the main power switch.
 - If the meter reads 230 VAC at the main power switch, sufficient power is being supplied, and the switch box is good. Continue this procedure with step 6.
6. Refer to Figure 5-21, and check for 240 VAC across the transformer secondary terminals H1-H4.
 - If the reading is 240 VAC across terminals H1-H4, replace the transformer.
 - If the meter does not read 240 VAC, check for open wires and loose connections at and between the main power switch, the terminal block, and the transformer.

CHAPTER 6. ILLUSTRATED PARTS LISTS

INTRODUCTION

This chapter illustrates replacement parts for the Cleveland Range model 24-CET-1 counter type convection steamer known as the Econocraft. The assembly diagram, Figure 6-1, is accompanied by a component parts list which includes the part name, part ordering number, and quantity used.

Parts Differences Among Econocraft Steamers

In the normal course of product improvement, component differences develop. Usually improved components are designed to be compatible with the existing structures. When this happens, the improved parts are provided automatically under the old part numbers. When this is not possible, the parts differences are tracked and identified by steamer serial numbers. These differences are noted in the illustrated parts list. Refer to Chapter 1 for an explanation of Cleveland Range serial number notation.

Electrical Wiring and Schematic Ladder Diagrams

In addition to parts illustrations, Econocraft Electrical Wiring and Schematic Ladder Diagrams are included at the end of the chapter, Figure 6-2 and 6-3, respectively.

Ordering Parts

When ordering parts for the EconoCraft include the following:

- | | |
|---------------------|------------------|
| • Model Number | From Parts List: |
| • Serial Number | • Item Number |
| • Voltage | • Part Number |
| • Quantity required | • Description |

Be sure to analyze the repair, disassembly, and assembly required. Order any gaskets, mounting hardware, or other consumables required.

The address for Cleveland Range, Inc. is on the front cover of this manual or call USA: (800) 782-0040, Canada: (416) 663-7770.

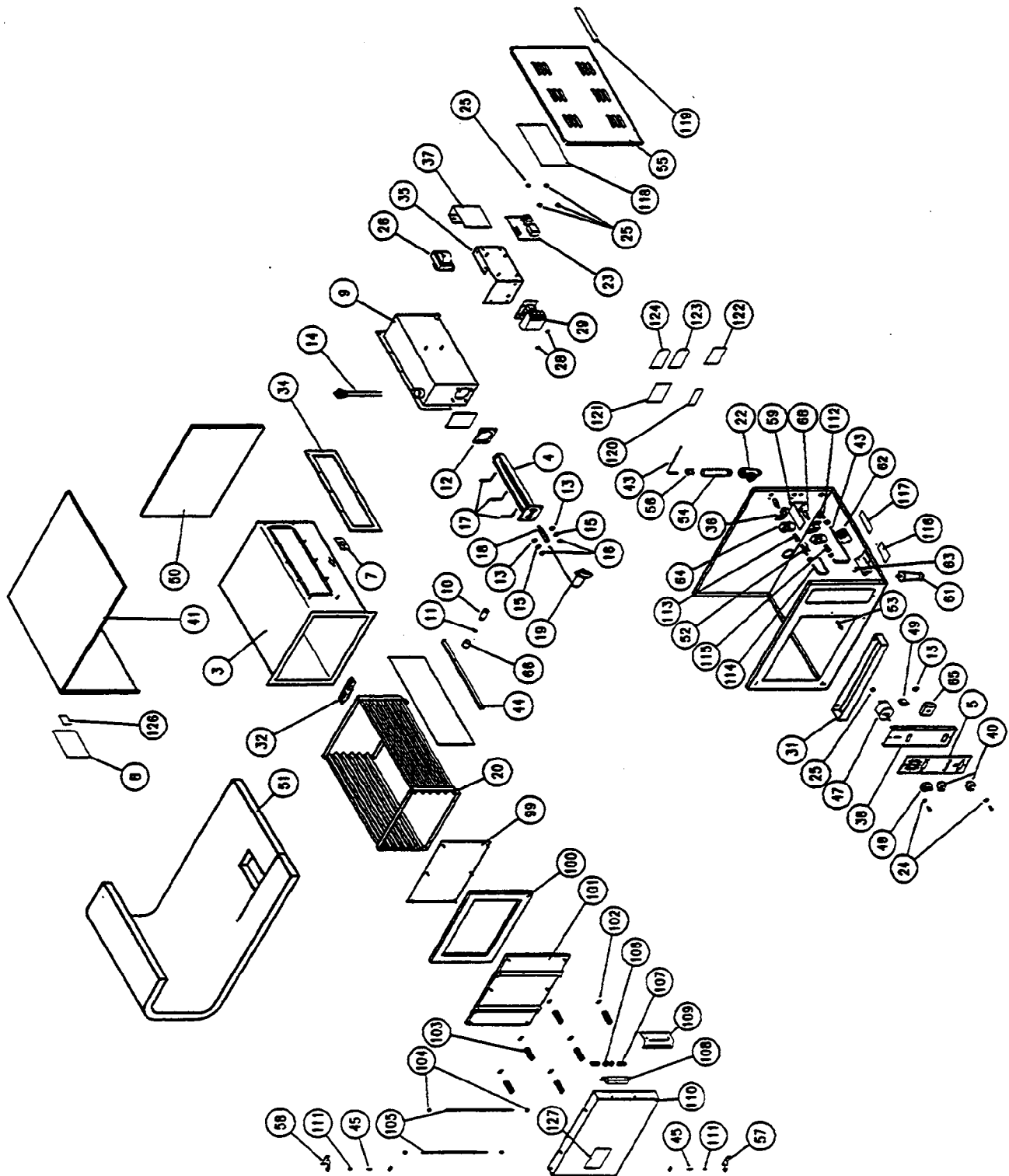

Figure 6-1. EconoCraft 24-CET-1

Figure 6-1. EconoCraft 24-CET-1 (Page 1 of 4)

Item No.	Part No.	Description	Quantity
1	D233	EconoCraft Label	1
2		Not Used	
3	1038521	Body, Assembly, Left Hinged	1
4	103881	Element, Immersion, 208V	1
5	1038811	Element, Immersion, 240V	1
6	103932	Label, Instrument Panel, EconoCraft	1
7	103850	Door Assembly	1
8	103742	Gasket, Drain	1
9	101770	Label, Model No./Serial No.	1
10	103794	Generator, Assembly	1
11	103925	Pin, Slide, Drain, PDQ	1
12	103810	O-Ring, 3/4 O.D. x .094 thick	1
13	07128	Gasket, Flange Heater Blockoff Plate, 3:	1
14	23116	Washer, Flat, 1/4" I.D. x 5/8" O.D. x .065 thick	4
15	103930	Probe, Generator, PDQ	1
16	23105	Washer, Lock Medium Pattern, 1/4" Katlink Style, S/S	4
17	14618	Nut, Hex, 1/4-20, S/S, Full Finished	6
18	103989	Clip, Capillary Retainer (Used before Date Code 92A)	3
19	103736	Adapter, Extended Compression (Used before Date Code 92A)	1
20	103731	Capillary, Hi Limit	1
21	103838	Pan, Support Assembly	1
22	104083	Diagram, Label Locating, PDQ	1
23	104071	Tee, Reducing 1 x 3/4 x 3/4, Black	1
24	23198	Control, Water Level	1
25	102574	Washer, Trim, #6, Nylon, Black	2
26	14874	Nut, Hex, 6032, Zinc Plated	4
27	103874	Transformer, 208/240V Primary	1
28	104004	Wire Assembly, 18 Gauge	1
29	100711	Washer, Internal Tooth Type A or B, #8, Zinc Plated	4
30	101899	Contact, 4 Pole, Lub Terminal, 30 AMP	1
31	14928	Tag, Hot Water Connection	1
	103842	Pan, Drip	1

Figure 6-1. EconoCraft 24-CET-1 (Page 2 of 4)

Item No	Part No.	Description	Quantity
32	1038581	Strainer, Drain, Assembly	1
33	1039011	Insulation, Component, PDQ	.122
34	103743	Gasket, Generator	1
35	1037541	Bracket, Weldment, Component Mounting	1
36	103734	Bracket, Solenoid Support	2
37	103808	Fishpaper, Formed	1
38	1037621	Weldment, Control Panel	1
39	1038081	Fishpaper, Formed	1
40	19993	Switch, Rocker, DPDT, On/Off, 6A, 125V, Matte Finish	2
41	103812	Top and Left Side Assembly	1
42	1022330800	Tubing, Polypropylene, 1/4" OD x 8" Long	1
43	1022333000	Tubing, Polypropylene, 1/4" OD x 30" Long	1
44	103845	Handle, Drain	1
45	103854	Pin, Hinge	2
46	103957	Fastener, 1/4-20" x 1/2" PEM, PDQ	4
47	20476	Timer, 60 Min, SP/DT, No Dial, Bulk Pack	1
48	11307	Knob, Timer Modified RC290	1
49	41350	Buzzer Assembly, W/Terminated Wire Leads	1
50	103901	Insulation, Rear	1
51	103902	Insulation, Blanket Body	1
52	103730	Valve, Needle Straight Comp. To Male Pipe	1
53	103804	Pin, Door Catch	1
54	103735	Conduit, Service	1
55	103811	Panel, Right Side	1
56	1038061	Clip Assembly, Chill Tube	1
57	1038401	Hinge, Door, Lower	2
58	103840	Hinge, Door, Upper	1
59	103809	Deflector, Condensate	1
60	103920	Carton, Cardboard	1
61	1014501	Leg, 4" High Appl., Fing. Fit, Thermo Plastic, Black	4
62	101352	Terminal Block Assembly, 4 Pole	1
63	20304	Lug, Ground	1

Figure 6-1. EconoCraft 24-CET-1 (Page 3 of 4)

Item No.	Part No.	Description	Quantity
64	22218	Valve, Solenoid, 1/4" Normally colsed Miniature 120 Volts	2
65	20477	Timer, Solid State, 3 Second, Delay on Break	1
66	103895	Spacer, Drain Valve	2
67	02609	Bushing, 1/4 x 1/8, Brass	2
68	103972	Adapter, 1/4" F x 1/4" M	2
69	234241300	Wire, Copper, #18 AWG, 13" Long, White	1
70	103991	Wire Assembly, 18 Gauge, Brown By-pass Sw to 3 sec T	1
71	103992	Wire Assembly, 18 Gauge, Pink TMR TI, By-Pass Sw.	1
72	103993	Wire Assembly, 18 Gauge, Orange TMR LI to By-pass Sw.	1
73	103994	Wire Assembly, 18 Gauge, Red Transolrm to STrip End	1
74	103995	Wire Assembly, 18 Gauge, Purple TMR T3, to Contactor	1
75	103996	Wire Assembly, 18 Gauge, Red TMR LI to HI Limit	1
76	103997	Wire Assembly, 18 Gauge, White Cont, to LI WLC Board	1
77	103998	Wire Assembly, 18 Gauge, Org., WL (LO) Board to Long PR	1
78	103999	Wire Assembly, 18 Gauge, Black WLC Board (LI) to Power Sw	1
79	104000	Wire Assembly, 18 Gauge, Green Board (GND) to Body	1
80	104001	Wire Assembly, 18 Gauge, Red WLC Board (HTR) to HI Limit	1
81	104002	Wire Assembly, 18 Gauge, Yellow Cool Down Sound, To Con	1
82	104003	Wire Assembly, 18 Gauge, Blue WLC Board (WF) to Fill S	1
83	104004	Wire Assembly, 18 Gauge, White Fill snd to Cool Down WLC Bd	1
84	104008	Wire Assembly, 18 Gauge, Yel., WLC Board (HI) to Probe (Short)	1
85	104063	Wire Assembly, 18 Gauge, White	1
86	23406220	Wire, Copper, 18 Gauge x 22.00, Black w/Tracer	1
87	234161500	Wire, Copper, 18 Gauge x 15.00, Blue w/Tracer	1
88	234330700	Wire, Copper, 12 Gauge x 7.00, White Tinned Ends	1
89	234330800	Wire, #12 AWG x 8.00, White	1
90	234330900	Wire, Copper, 12 Gauge x 9.00, White Tinned Ends	1
91	234331000	Wire, Copper, 12 Gauge x 10.00, White Tinned Ends	1
92	234240800	Wire, Copper, #18 AWG, 8" Lg., White	1
93	104005	Wire Assembly, 18 Gauge, White x 2 Transform to LI Pwr Sw.	1
94	103990	Wire Assembly, 18 Gauge, Grey TMR TI to 3 Sec TMR	1
95	1040041	Wire Assembly, 18 Gauge, White, Fill Sol to Cool Down	1

Figure 6-1. EconoCraft 24-CET-1 (Page 4 of 4)

Item No.	Part No.	Description	Quantity
96	104300	Label, Model No./Serial No. (Multiple Listing)	1
97	104006	Wire Assembly, 18 Gauge, Black x 1 Transform to Pwr Sw.	1
98	102573	Screw, Pan Head Phillips, 6-32 x 3/4, Matte Black Finish, S	2
99	103748	Gasket Assembly, Retainer	1
100	103744	Gasket, Door	1
101	103750	Gasket, Pan Support Assembly	1
102	103847	Spring, Support	6
103	103797	Spring, Door	6
104	103755	Snap Cap kit	4
105	103800	Pin Assembly, Door Seal	2
106	103892	Rollers, Latch	2
107	103790	Spring, latch	2
108	103791	Retainer, Spring Latch	1
109	103846	Handle, Door	1
110	1038571	Door, Outer	1
111	02624	Bearing (Bushing For Door)	1
112	06214	Filling	1
113	02609	Reducer	1
114	1022331000	Tubing (Fill Tube)	1
115	06216	Fitting, Straight Compression	1
116	14897	Label, Ground	1
117	103775	Label, Wild Leg	1
118	103759	Label, Schematic	1
119	14932	Label, Disconnect	1
120	103893	Label, Plumbing Caution	1
121	103739	Label, Water Hardness	1
122	14912	Label, Electrical Notice	1
123	1492813	Tag, Hot Water Connect	1
124	1492913	Tag, Cold Water Connect	1
125	1017701	Label, Model and Serial No.	1
126	14814	Label, N.S.F.	1
127	103740	Label, Cleaning Instruction	1

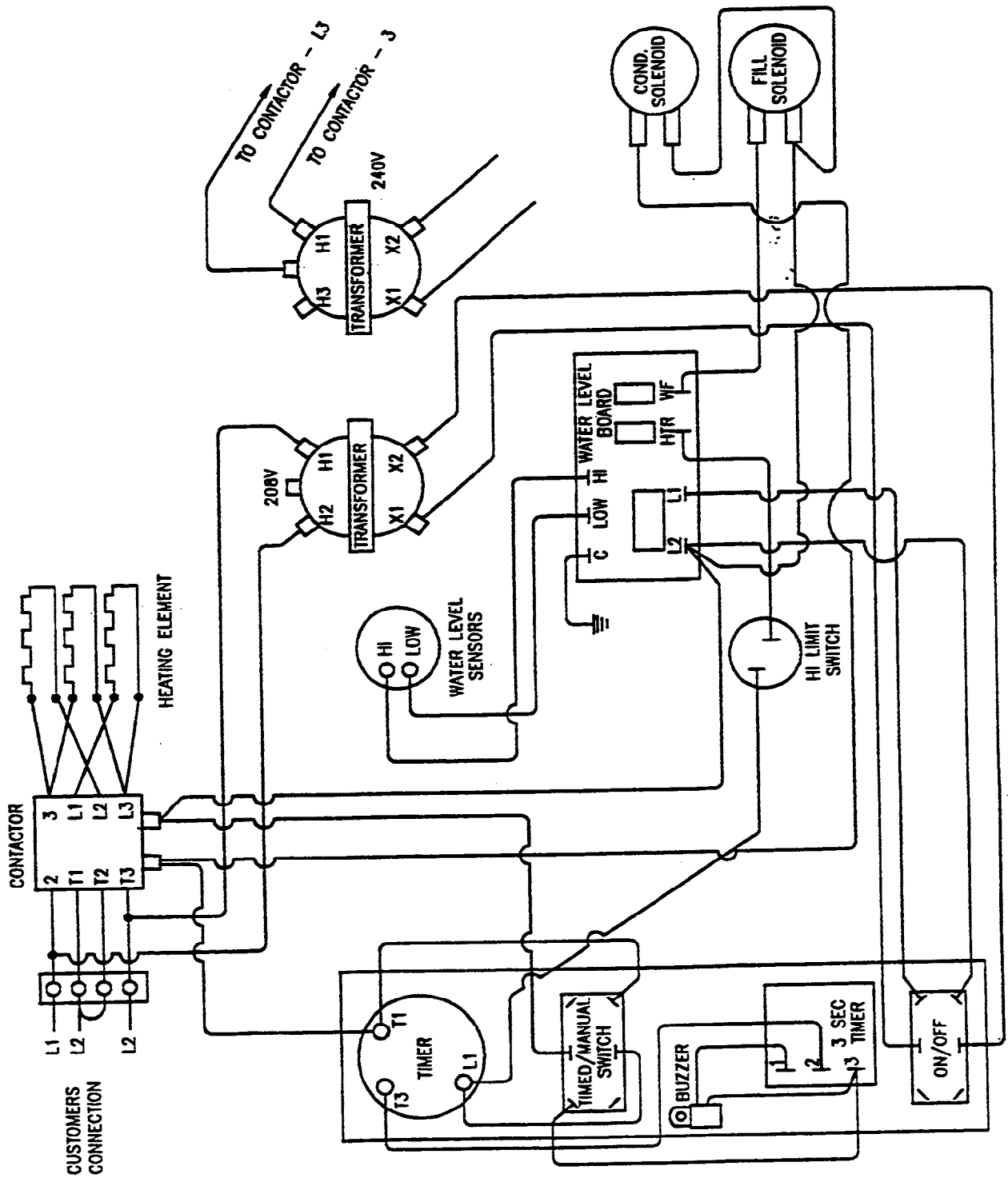

Figure 6-2. 24-CET-1 Electrical Wiring Diagram

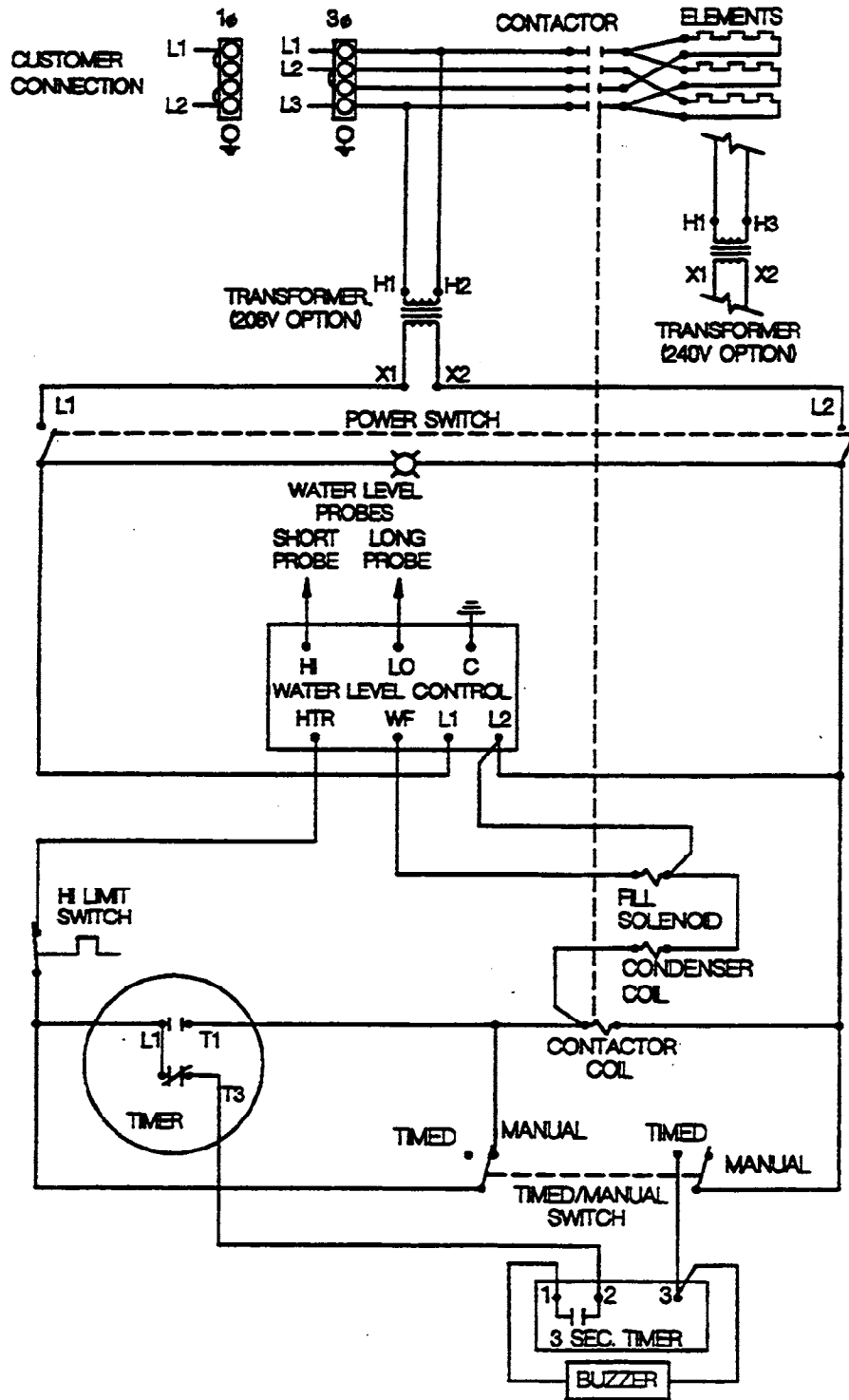

Figure 6-3. 24-CET-1 Schematic Ladder Diagram

