

# TWO COMPARTMENT, PRESSURELESS, ELECTRIC STEAM GENERATOR, 24, 36 OR 48 KW, 24" WIDE CABINET BASE DESIGN

Project \_\_\_\_\_  
 Item \_\_\_\_\_  
 Quantity \_\_\_\_\_  
 FCSI Section 11400 \_\_\_\_\_  
 Approved \_\_\_\_\_  
 Date \_\_\_\_\_

Classic Series Convection Steamers, 15 PSI Boiler Base Style

## Models

- 24-CEM-24
- 24-CEM-48
- 24-CEM-36



- Durable 14 Gauge Stainless Steel Construction: For Compartment Door and Steam Cooking Cavity.
- Separate Main Power Switch for "On/Off"
- Exclusive Steam Cooking Distribution System: The exclusive Convection Jets produce a high velocity convection steam without fans. Coved Corner design in cooking compartment distributes heat evenly and is easy to keep clean. Creased top & bottom enhance drainage. Cold Water Condenser for each compartment maintains a dry steam. Fully insulated cooking compartment for thermal efficiency. Removable Stainless Steel Slide Racks for easy cleaning.
- Exclusive "Cool to the Touch" Compartment Door Design: Free floating inner door with reversible door gasket provides an air tight seal. Stainless Steel Slam/Latch Door Latch mechanism provides greater reliability.
- Left Hand Door Hinging: Compartment Doors hinged left, controls on the right.
- Modular Cabinet Base with Hinged Door.
- Electric Steam Generator: Automatic Water Fill on start up.
- Automatic Generator Drain at shutdown: Contains a "Water Jet" Spray Rinse Cleaning Cycle to keep drain clear.
- Automatic Water Level Control System with Low Water Power Cut-off Circuit.
- Steam generator equipped with High Limit Pressure Safety Switch, 15 psi Safety Valve, and Steam Generator Pressure Gauge.
- Secondary Low Water Cut-Off, factory installed (CALE) (Required for AZ. AR. CA. CO. CT. DE. FL. GA. HI. IL. IA. KS. MD. MA. MI. MN. MT. NE. NV. NM. NC. OK. OR. PR. RI. TN. UT. VA. WA. WV., Buffalo, NY, Wash. DC)
- NSF Certified 6" Stainless Steel Legs with adjustable flanged feet for a one inch level adjustment.
- Standard voltage 208 or 240 volts, 60 Hz, 3 phase.
- All Controls are serviceable from the front.

## Short Form Specifications

Shall be Two Compartments, CLEVELAND Convection Steamer, Model 24-CEM- \_\_\_\_\_, Electric Steam Generator, \_\_\_\_\_ KW, \_\_\_\_\_ volts, \_\_\_\_\_ phase, 3 wire. Solid State Controls operate timing, water level and safety functions. Electric Steam Generator with Automatic Water Fill on start-up and Automatic Blowdown with additional Manual Drain Valve, For each cooking compartment: 60 minute Mechanical Timer, Manual Operation Mode and Cold Water Condenser. Type 304 Stainless Steel cooking compartment.

## Standard Features

- Cooking Capacity for up to six 12" x 20" x 2 1/2" deep Cafeteria Pans.
- Pressureless cooking with forced convection steam, permitting doors to be opened while cooking continues.
- Solid State Controls operate water level and safety functions.
- Each compartment is equipped with a 60 minute mechanical timer, separate bypass switch for constant steaming and a cold water condenser for superior cooking results.
- Instant Steam Standby Mode: Holds generator at steaming temperature. Allows unit to start cooking instantly.

## Options & Accessories

- Cafeteria pans in depths of 1", 2 1/2", 4" and 6"
- Voltages other than standard
- Power Take Off Kit (EPTO), Kettle Interconnecting Kit (IMK)
- Correctional Packages
- Boiler Descaling Pump Kit (107142)
- Water Filters

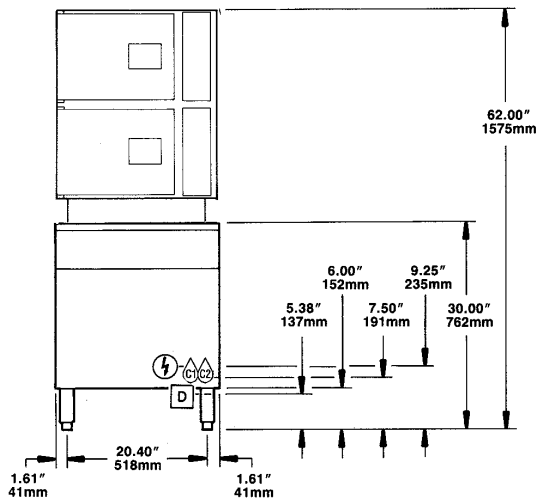
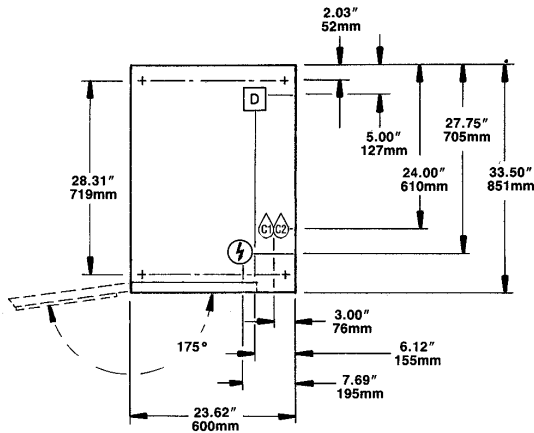

**NOTE:** When ordering optional reverse door openings: Control Panel, door openings and cooking compartments are opposite that shown.

**COMPARTMENT HAS CAPACITY FOR:**

- Three, 12" x 20" x 2 1/2" deep Cafeteria Pans

**NEW WATER QUALITY REQUIREMENTS (Boilers, Generators)**

|                          |                         |
|--------------------------|-------------------------|
| TDS:                     | 50-125 ppm              |
| Hardness:                | 50 - 125 mm (3 - 6 gpg) |
| pH value:                | 7.0 - 8.5               |
| CL (Chloride):           | max 25 ppm              |
| Cl2 (free chlorine):     | max 0.1 ppm             |
| SiO42 (sulfate):         | max 150 ppm             |
| Fe (iron):               | max 0.1 ppm             |
| SiO2 (silica):           | max 13 ppm              |
| NH2Cl: (mono-chloramine) | max 0.1 ppm             |
| Total Alkalinity:        | 50 - 100 ppm            |
| Water Pressure           | 35 - 80 PSI             |
| Temperature:             | max 104°F               |

**ELECTRIC** ⚡

| KW | Volts | Watts  | Ph | Amps | Wire |
|----|-------|--------|----|------|------|
| 24 | 208   | 21,500 | 3  | 59.7 | 3    |
|    | 220   | 24,000 | 3  | 63.1 | 3    |
|    | 240   | 24,000 | 3  | 57.8 | 3    |
|    | 440   | 20,200 | 3  | 26.5 | 3    |
|    | 480   | 24,000 | 3  | 28.9 | 3    |

| KW | Volts | Watts  | Ph | Amps | Wire |
|----|-------|--------|----|------|------|
| 36 | 208   | 32,200 | 3  | 89.5 | 3    |
|    | 220   | 36,000 | 3  | 94.6 | 3    |
|    | 240   | 36,000 | 3  | 86.7 | 3    |
|    | 440   | 30,200 | 3  | 39.7 | 3    |
|    | 480   | 36,000 | 3  | 43.4 | 3    |

| KW | Volts | Watts  | Ph | Amps  | Wire |
|----|-------|--------|----|-------|------|
| 48 | 208   | 42,900 | 3  | 119.2 | 3    |
|    | 220   | 48,000 | 3  | 126.1 | 3    |
|    | 240   | 48,000 | 3  | 115.6 | 3    |
|    | 440   | 40,300 | 3  | 52.9  | 3    |
|    | 480   | 48,000 | 3  | 57.8  | 3    |

| WATER  | DRAINAGE  | CLEARANCE   |
|--|---|---|
| 1/4" NPT Cold Water Inlet<br>35 psi minimum<br>60 psi maximum<br>Condenser Feed<br>Boiler Feed | The Floor Drain must be located outside the confines of the equipment base.<br>1 1/2" I.P.S. common drain.<br>Do not connect other units to this drain.<br>Do not use PVC pipe for drain. | Right - 3", Left - 3", Rear - 3" (12" on control side if adjoining wall or equipment is over 30" high for service access)<br>Contact factory for variances to clearances. |

**NOTES:**

Cleveland Range reserves right of design improvement or modification, as warranted.  
 Many regional, state and local codes exist and it is the responsibility of the owner and installer to comply with the codes.  
 Cleveland Range equipment is built to comply with applicable standards for manufacturers. Included among those approval agencies are ASME/N. Bd, UL and NSF.

(NOT TO SCALE)