

Operator's Manual

Operation, Use, and Care Instructions Steam Cooker



Series: SteamChef™ Gas Models 22CGT3.1 and 22CGT6.1

1333 East 179th Street
Cleveland, Ohio 44110

Phone: (216) 481-4900
1-800-338-2204

Fax: (216) 481-3782
www.clevelandrange.com

 **Cleveland**

Part No. 22CGT3.1&6.1-OPM REV. B 6/09

FOR YOUR SAFETY

Do not store or use gasoline or other flammable vapors or liquids in the vicinity of this or any other appliance.

⚠ WARNING

Improper installation, adjustment, alteration, service or maintenance can cause property damage, injury or death. Read the installation, operating and maintenance instructions thoroughly before installing or servicing this equipment.

NOTICE

Post instructions to be followed if the user smells gas.
Display the instructions in a prominent location.
All users of this equipment must understand the instructions.
Obtain the instructions from the local gas supplier.
Failure to follow the instructions if there is a gas leak can cause death, injury, and/or property damage.

⚠ DANGER

ELECTRIC SHOCK HAZARD

DEATH, INJURY, or EQUIPMENT DAMAGE can result from touching any component inside this appliance when the power is connected.

Whenever possible disconnect the power while installing, servicing, or testing.

When installation, service, or tests require power to be connected; use extreme caution and every possible precaution and safety measure while installing, servicing, or testing this appliance.

⚠ WARNING

Do not connect the drain connection to any drain material that cannot sustain 140° Fahrenheit.

Using drain material that cannot withstand 140° Fahrenheit can result in injury, equipment damage, and property damage.

**ALL SERVICE MUST BE PERFORMED BY A QUALIFIED
CLEVELAND RANGE AUTHORIZED TECHNICIAN.**

KEEP THIS MANUAL FOR REFERENCE

This manual may be subject to new technical developments, modifications, and unforeseen errors.

**DO NOT OPERATE OR ATTEMPT TO OPERATE THIS APPLIANCE OR ANY ACCESSORIES WITHOUT READING
COMPLETELY AND FULLY UNDERSTANDING THIS MANUAL**

Cleveland Range SteamChef appliances are intended for other than household use.

Cleveland STATEMENT OF POLICIES

LIMITED WARRANTY

CLEVELAND RANGE products are warranted to the original purchaser to be free from defects in materials and workmanship under normal use and service for the standard warranty period of one year from date of installation or 18 months from date of shipment, whichever ever comes first.

CLEVELAND RANGE agrees to repair or replace, at its option, f.o.b. factory, any part which proves to be defective due to defects in material or workmanship during the warranty period, providing the equipment has been unaltered, and has been PROPERLY INSTALLED, MAINTAINED, AND OPERATED IN ACCORDANCE WITH THE CLEVELAND RANGE OWNER'S MANUAL.

CLEVELAND RANGE agrees to pay any FACTORY AUTHORIZED EQUIPMENT SERVICE AGENCY (within the continental United States, and Hawaii) for reasonable labor required to repair or replace, at our option, f.o.b. factory, any part which proves to be defective due to defects in material or workmanship, during the labor warranty period. This warranty includes travel time not to exceed two hours and mileage not to exceed 50 miles (100 miles round-trip), BUT DOES NOT INCLUDE POST START-UP, TIGHTENING LOOSE FITTINGS, MINOR ADJUSTMENTS, MAINTENANCE, CLEANING OR DESCALING.

The standard labor warranty allows factory payment of reasonable labor required to repair or replace such defective parts. Cleveland Range will not reimburse the expense of labor required for the repair or replacement of parts after the standard warranty period, unless an Extended Labor Warranty Contract has been purchased to cover the equipment for the balance of the warranty period from the date of equipment installation, start-up, or demonstration.

PROPER INSTALLATION IS THE RESPONSIBILITY OF THE DEALER, THE OWNER-USER, OR INSTALLING CONTRACTOR, AND IS NOT COVERED BY THIS WARRANTY. Many local codes exist, and it is the responsibility of the owner and installer to comply with these codes. Cleveland Range equipment is built to comply with applicable standards for manufacturers, including UL, ANSI, NSF, ASME/Ntl. Bd., CSA, and others.

BOILER (Steam Generator) MAINTENANCE IS THE RESPONSIBILITY OF THE OWNER-USER AND IS NOT COVERED BY THIS WARRANTY. The use of good quality feed water is the responsibility of the Owner-User (see Water Quality Recommendations below). THE USE OF POOR QUALITY FEED WATER WILL VOID EQUIPMENT WARRANTIES. Boiler maintenance supplies, including boiler hand hole gaskets, are not warranted beyond the first 90 days after the date the equipment is placed into service. Preventive maintenance records must be available showing descaling per applicable Cleveland Operator Manual for Boiler Proration Program considerations.

WATER QUALITY RECOMMENDATIONS

TOTAL DISSOLVED SOLIDS	less than	60 parts per million
TOTAL ALKALINITY	less than	20 parts per million
SILICA	less than	13 parts per million
CHLORIDE	less than	30 parts per million
pH FACTOR	greater than	7.5

The foregoing shall constitute the sole and exclusive remedy of original purchaser and the full liability of Cleveland Range for any breach of warranty. THE FOREGOING IS EXCLUSIVE AND IN LIEU OF ALL OTHER WARRANTIES, WHETHER WRITTEN, ORAL, OR IMPLIED, INCLUDING ANY WARRANTY OF PERFORMANCE, MERCHANTABILITY, OR FITNESS FOR PURPOSE, AND SUPERSEDES AND EXCLUDES ANY ORAL WARRANTIES OR REPRESENTATIONS, OR WRITTEN WARRANTIES OR REPRESENTATIONS, NOT EXPRESSLY DESIGNATED IN WRITING AS A "WARRANTY" OR "GUARANTEE" OF CLEVELAND RANGE MADE OR IMPLIED IN ANY MANUAL, LITERATURE, ADVERTISING BROCHURE OR OTHER MATERIALS.

CLEVELAND RANGE'S liability on any claim of any kind, including negligence, with respect to the goods or services covered hereunder, shall in no case exceed the price of the goods or services, or part thereof, which gives rise to the claim. IN NO EVENT SHALL CLEVELAND RANGE BE LIABLE FOR SPECIAL, INCIDENTAL, OR CONSEQUENTIAL DAMAGES, OR ANY DAMAGES IN THE NATURE OF PENALTIES.

LIMITED EXTENDED WARRANTY COVERAGE

The purchase of a Limited Extended Warranty Contract extends the standard warranty coverage to the purchased period of time (one to two years) from the date of installation, start-up, or demonstration, whichever is sooner.

*An additional two years Parts and Labor Warranty can be purchased with each piece of Cleveland equipment for an additional 2% of the List Price per year. The 2% of list price charge will be the net invoice amount for each year of extended warranty purchased.

- Extended warranty must be purchased at the same time the equipment is purchased.
- Extended Warranty has the same exclusions as stated in our standard warranty.

Second year limited extended warranty coverage on Cleveland Steamers when purchased with a water filter applies to water related components only.

Free Start-Up Program

Get the most from your Cleveland Range equipment with Cleveland Range's "Free Start-Up."

Performance Check-Out: Contact your Cleveland Range maintenance and repair center for your Performance Check-Out before starting your new Cleveland Range Steamer.

The Performance Check-Out includes:

Inspection of the Installation
Review of Cleaning Procedures
Review of Maintenance Procedures
Start of Warranty Protection

Equipment Demonstration: After your Performance Check-Out, contact your Cleveland Range sales representative for your free Equipment Demonstration.

The Equipment Demonstration includes:

Proper Operation
Optimized Use
Care, Cleaning, and Maintenance

To arrange for your free Start-Up Program appointment consult your Customer Service Directory or call Cleveland Range at:

216-481-4900

OR

1-800-338-2204

Ask your sales representative for more information about uses for your SteamChef.

Operator's Manual
SteamChef Models 22CGT3.1 and 22CGT6.1
Table of Contents

Chapter		Page
1	GENERAL SAFETY.....	1
	A. Gas Leak Instructions.....	1
	B. Operational Safety.....	1
2	PRODUCT INFORMATION.....	2
	A. Product Information.....	2
	B. Model Numbers and Serial Numbers.....	2
	C. Product Information Plate.....	2
	Figure 2-1 Product Views.....	3
3	OPERATION.....	4
	A. Main External Power Switch.....	4
	B. Door Interlock Switch.....	4
	C. To Install/Remove the Fan Guard.....	4
	D. To Install/Remove the KleanShield™.....	5
	E. To Install/Remove the Slide Racks (Pan Racks).....	5
	F. To Inspect the Cooking Compartment.....	5
	G. Power ON (Automatic Water Fill / Automatic Preheat).....	6
	H. Lighting and Shutdown Instructions (Normal Operation and Power Failure).....	6
	I. To Preheat the SteamChef.....	7
	J. High Limit Lockout.....	7
4	CONTROL PANELS.....	9
	A. ON/OFF Control Panel.....	9
	B. Dial Timer Control Panel.....	10
	C. Keypad Control Panel.....	11

Operator's Manual
SteamChef Models 22CGT3.1 and 22CGT6.1
Table of Contents
(Continued)

5	COOKING WITH THE SteamChef.....	12
	A. Operating and Cooking Procedure – All Models.....	13
	B. Operating and Cooking Procedure – Timed Mode.....	13
	C. Operating and Cooking Procedure – Manual Mode.....	13
	D. Operating and Cooking Procedure – ON/OFF Control Panel.....	14
	E. Operating and Cooking Procedure – Rethermalization.....	14
6	CLEANING THE SteamChef.....	15
	Cleaning Procedure.....	16
7	PREVENTATIVE MAINTENANCE AND TROUBLESHOOTING.....	17
	A. Maintenance.....	17
	1. Maintenance Records.....	17
	2. Daily Maintenance.....	17
	3. Scheduled Cleaning of the SteamChef.....	17
	4. Yearly Maintenance – Cleaning the Filter Washers.....	17
	5. Other Maintenance – Periodic Descaling of the Water Reservoir.....	18
	B. Operators' Troubleshooting Guide.....	20

CHAPTER 1

GENERAL SAFETY

To use a SteamChef Steam Cooker (steamer) safely and effectively, each operator must read and understand this manual completely before starting operation. The owner and operator(s) of SteamChefs must keep these instructions in an easily accessible location for reference and training.

The owner and operator(s) of SteamChefs must be aware that steam can cause serious injuries and equipment damage. Pay particular attention to the Operational Safety section of this chapter, and the warnings in this manual and on the equipment.

A. Gas Leak Instructions

⚠ DANGER

**GAS LEAKS ARE FIRE AND EXPLOSION HAZARDS.
INJURY, DEATH, AND PROPERTY DAMAGE WILL RESULT.**

If anyone smells gas, or suspects there is a gas leak, immediately refer to the posted gas leak instructions. The posted instructions are provided by the local gas supplier, and supersede any other instructions.

Observe the following precautions in addition to the posted instructions:

- **Do NOT light or start any appliance.**
- **Do NOT touch any electrical switch.**
- **Do NOT use any phone in the building.**
- **Immediately call the gas supplier from a phone away from the building.**
- **Follow the gas supplier's instructions.**
- **If the gas supplier cannot be reached, call the fire department.**

B. Operational Safety

The Operational Safety section outlines minimum safety policies and procedures for operating one or more SteamChef steamers.

1. Do not store anything on top of the SteamChef.
2. Keep the area around and under the SteamChef free and clear of combustible materials.
3. Do NOT obstruct the flow of combustion and ventilation air to the SteamChef.
4. Place non-slip draining anti-fatigue mats rated for use in wet, greasy, or dry work areas on the floor in front of the SteamChef and other locations as needed. Obtain the best mats for your needs from your local supplier.
5. Wear BOOTS appropriate to the work area to help protect feet, and to help prevent slips and falls.
6. Allow only qualified Cleveland Range authorized service representatives to service the SteamChef.
7. Use only factory authorized repair parts.
8. Maintain written records of SteamChef service, maintenance, and repair. Each record must include at least:
 - a. The date of the service, maintenance, or repair.
 - b. A description of the service, maintenance, or repair performed.
 - c. Copies of purchase order(s) and invoice(s) for repair parts and service, maintenance, or repair. Include part numbers, if applicable.
 - d. The name and signature of the person performing the service, maintenance, or repair.

CHAPTER 2

PRODUCT INFORMATION

A. Product Information This manual covers the operation of SteamChef Steam Cookers (steamers), Cleveland Range models 22CGT3.1 and 22CGT6.1 and covers the standard features and options available on SteamChef steamers.

- Other than the selection of options and size (3 or 6 pan), there are presently no significant design, parts, or operating differences among SteamChefs with these model numbers.
- Figure 2-1 illustrates the major external features of SteamChefs.
- For further information, contact your Cleveland Range sales representative or Cleveland Range.

B. Model Numbers and Serial Numbers

1. Cleveland Range, LLC assigns two product identification numbers to each SteamChef: a model number and a serial number. The model number identifies the product characteristics. The serial number identifies the individual SteamChef.
2. Please provide the model number and serial number when you contact Cleveland Range or a qualified Cleveland Range authorized service representative.

Serial Number _____
(Write the Serial Number of your SteamChef here.)

Model Number _____
(Write the Model Number of your SteamChef here.)

C. Product Information Plate

The Product Information Plate is on the side opposite the control panel. It lists the model, serial number, gas, electric, and wiring requirements of the SteamChef.

Product Views

Figure 2-1

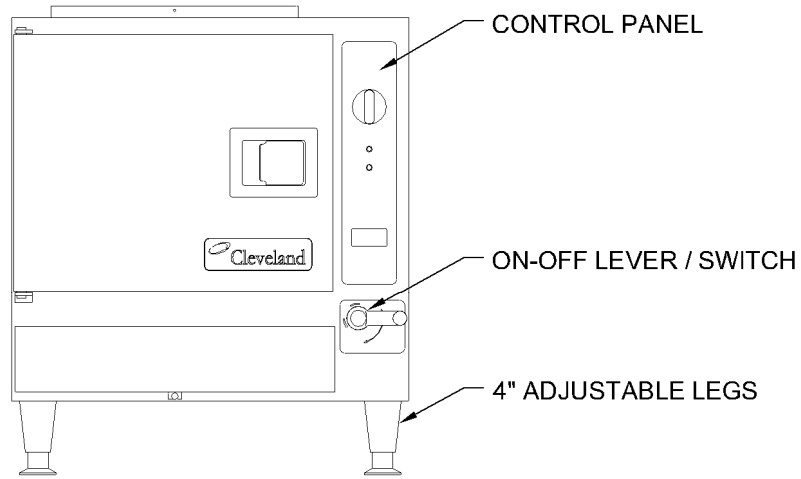

FRONT VIEW

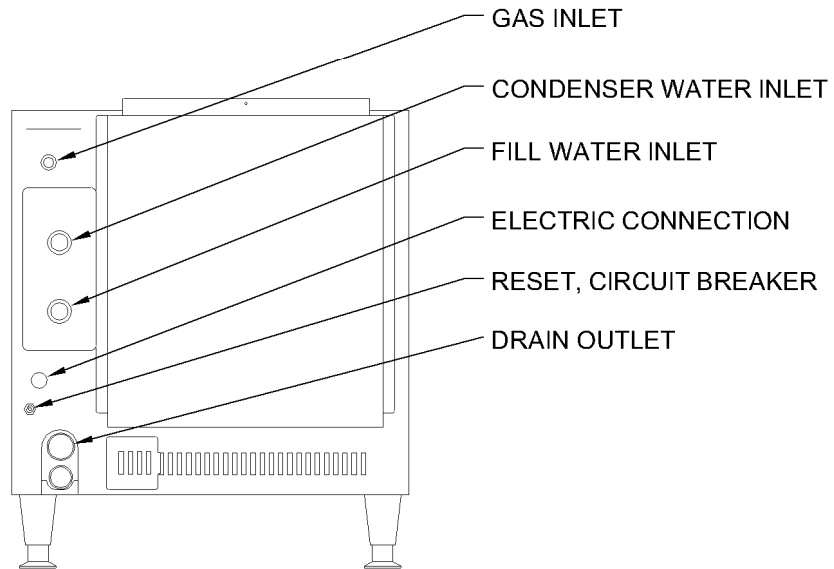

BACK VIEW

CHAPTER 3 OPERATION

A. Main External Power Switch

- Usually, the SteamChef's Main External Power Switch is left ON during operating hours. If the Main External Power Switch is OFF, turn it ON as follows:
 1. Turn the ON/OFF lever/switch to the OFF position.
 2. The control panel settings are not important in this procedure. The control panel circuits are not powered while the ON/OFF lever/switch is OFF.
 3. Refer to Figure 3-1 and turn on electric power to the SteamChef at the Main External Power Switch.

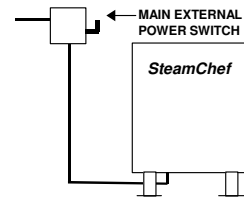

**Figure 3-1
Main External Power Switch**

B. Door Interlock Switch

The cooking compartment of the SteamChef is equipped with an automatic door interlock switch, which turns OFF the burner, fan, and stops the Timer when the door to a cooking compartment is opened.

⚠ WARNING

Burn and Scald Hazard

Even though the burner shuts off as soon as a door is opened, it may take up to a minute for production of steam to end and residual steam in the system to clear from the cooking compartment. To help avoid injury always wait until the residual steam clears and the convection fan stops before reaching into the cooking compartment, and always wear dry heatproof gloves when reaching into the cooking compartment. Wet or damp gloves conduct heat and can cause burns when touching hot items. Failure to do so can cause burns, scalds, and other injuries.

C. To Install/Remove the Fan Guard and Air Diverter

1. To Install the fan guard and air diverter:
 - a. Hold the fan guard so that the large ends of the keyholes are towards the bottom of the SteamChef.
 - b. Place all four openings over the mounts located on the rear wall of the SteamChef.
 - c. Pull it down so that the narrow ends of the slots are pulled tight over the mounts. See Figure 3-2.
 - d. Place the air diverter over the fan guard. Press lightly towards the rear wall until the air diverter drops into its slots in the fan guard.
2. To REMOVE the fan guard and air diverter:
 - a. Lift the air diverter up and out of its slots in the fan guard.
 - b. Tilt the air diverter back and slide it over the fan guard.
 - c. Push up on the fan guard and slide the wide end of the slots over the mounts.

⚠ WARNING

The fan guard helps protect the operator from injury caused by the rotating fan blades. Never operate a SteamChef without the fan guard properly installed. Operating a SteamChef without the fan guard properly installed can cause injury, equipment damage, and reduce performance.

D. To Install/Remove the KleanShield™

Note: The KleanShield™ is dishwasher safe.

⚠ WARNING

Never operate a SteamChef without the KleanShield™ properly installed. The properly installed KleanShield™ helps protect the operator from scalding water splashing out of the reservoir, and helps prevent drain blockage. Operating a SteamChef without the KleanShield™ properly installed can cause injury, equipment damage, and reduce performance.

1. To Install the KleanShield™.
 - a. Place the KleanShield™ into the SteamChef so the drain trough slips into the KleanShield™ drain at the rear of the cooking compartment.
 - b. Carefully lower the front of the KleanShield™ so the Water Level Sensor Guard is behind the probes and the front legs rest on the bottom of the cooking compartment.
2. To Remove the KleanShield™, wait for the SteamChef to cool, carefully lift the front of the KleanShield™ and remove the KleanShield™ from the cooking compartment.

E. To Install/Remove the Slide Racks (Pan Racks)

1. See Figure 3-2. Each rack has four loops: two at the top and two at the bottom. Hold the slide rack so the ends of the hanger loops are towards the cooking compartment wall.
 - a. Slide a rack into the compartment with the hanger loops on the cooking compartment wall side.
 - b. Hook the loops over the top and bottom pins.
 - c. Repeat steps a and b for the other rack.
2. To REMOVE the slide racks, unhook the loops over the top and bottom pins and remove the racks.

F. To Inspect the Cooking Compartment

1. Before turning ON the power switch/lever to the SteamChef, the inside of the SteamChef must be clean. See Chapter 6.
2. Inspect the door gasket assembly, water level sensors, KleanShield™, drain screen, fan guard, air diverter, and slide racks for proper installation and cleanliness. See Figure 3-2.
3. Make sure that the KleanShield™ drain is clear. If the drain is blocked or slow, do NOT start the SteamChef until it has been cleaned. See Chapters 6 and 7 for Cleaning and Troubleshooting procedures. To check the drain:
 - a. Pour about a quart of water through the KleanShield™ drain.
 - b. Check that the water flows out the drain and drainpipe.

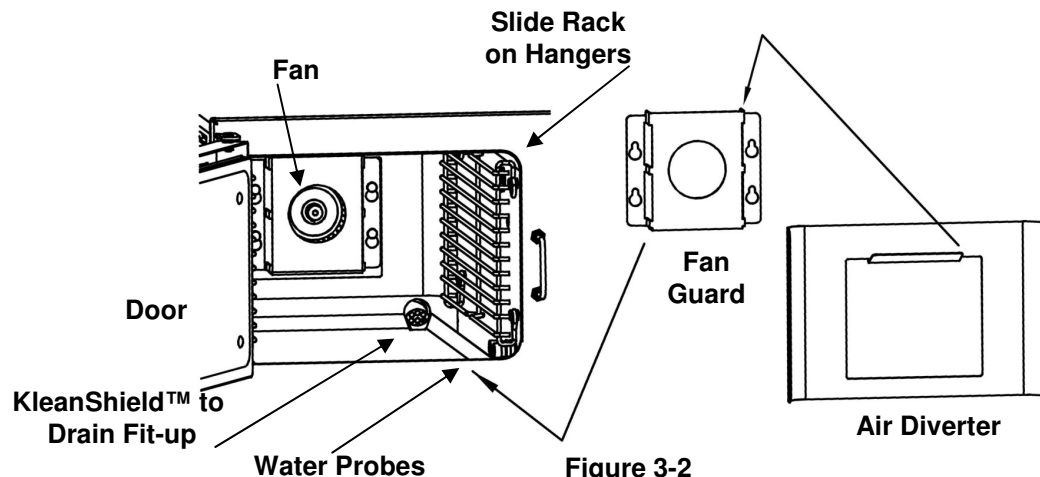

Figure 3-2
Cooking Compartment

G. Power ON (Automatic Water Fill / Automatic Preheat)

1. Set the TIMED/MANUAL switch to timed (Dial Timer SteamChefs) or set the selector switch to OFF (ON/OFF control SteamChefs).
2. Turn on the utilities (if not already on).
3. Turn ON power to the SteamChef by turning the Drain Valve Lever clockwise (down) to close the drain. See Figure 3-3.
4. The power ON indicator lights and the SteamChef reservoir fills.
5. Close the door. The SteamChef fills to the minimum operating level and the burner ignites.

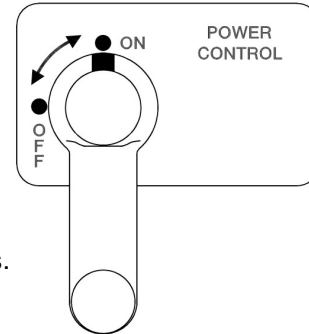

Figure 3-3
Drain Valve Lever

H. Lighting and Shutdown Instructions (Normal Operation and Power Failure)

1. Lighting and Shutdown Instructions for Normal Operation

DANGER

**Do NOT attempt to operate a SteamChef during a power failure!
DEATH, INJURY, and EQUIPMENT DAMAGE can result.
Follow the Power Failure Shutdown Instructions.**

DANGER

DO NOT TRY TO LIGHT BURNERS WITH A FLAME.

The SteamChef has an electronic ignition system, which automatically lights burners, senses the flame, and controls gas flow. This provides precise burner control, safe ignition, and safe shutdown.

DEATH, INJURY, OR EQUIPMENT DAMAGE may result from trying to light burners with a flame or from an improperly adjusted gas control and ignition system. Do not try to light burners with a flame. Do not alter any gas control adjustments.

If adjustment is required, contact a Cleveland Range authorized service center. Cleveland Range is in no way responsible for the operation or safety of this equipment if the controller, valve, igniter probe or any other gas system component is adjusted by anyone other than a qualified Cleveland Range authorized service representative

The following START-UP SUMMARY is for quick reference ONLY. For safe operation and use of this equipment, the operator must comply with all safety and operating instructions in this manual.

LIGHTING INSTRUCTIONS

- 1) CLOSE THE COOKING COMPARTMENT DOOR.
- 2) TURN THE ON/OFF LEVER/SWITCH CLOCKWISE TO THE ON POSITION.
 - RESERVOIR WILL FILL WITH WATER (ABOUT 1 MINUTE).
 - SPARK WILL INITIATE AND MAIN GAS VALVE WILL OPEN FOR 4 SECONDS.
 - IF THE UNIT FAILS TO LIGHT WITHIN 4 SECONDS GAS VALVE WILL CLOSE AND LOCKOUT AND A CONTINUOUS BUZZER WILL SOUND.
- 3) SYSTEM MAY BE RESET MANUALLY BY TURNING THE ON/OFF LEVER/SWITCH OFF FOR 5 MINUTES AND BACK ON.

SHUTDOWN INSTRUCTIONS

- 1) TURN OFF THE ON/OFF LEVER/SWITCH.
- 2) WAIT FOR THE 3-MINUTE DRAIN RINSE CYCLE TO RUN.
- 3) TURN OFF THE MAIN EXTERNAL POWER SWITCH.
- 4) TURN OFF THE MAIN MANUAL GAS VALVE.

2. In the Event of a Power Failure

- In the event of a power failure, do NOT attempt to operate this appliance.

I. To Preheat the SteamChef

Preheating the SteamChef helps ensure productivity and consistency. Preheat before cooking, and reheat as needed between batches of food.

BEFORE PREHEATING inspect and clean the compartment. After preheating, the compartment will be too hot to inspect and clean safely.

To preheat the SteamChef:

- a. Turn the SteamChef ON 15 minutes before cooking to allow time for the water reservoir to fill and SteamChef to heat:
 - 1) Close the SteamChef door.
 - 2) Select Timed mode.
 - 3) Set the Timer to 0.
 - 4) Turn ON the ON/OFF lever.
- b. The SteamChef heats to the operating temperature.

J. High Limit Lockout

This SteamChef has a High Limit Lockout to protect the SteamChef from overheating.

1. If the SteamChef reaches the high limit temperature, the RESET light turns ON, a buzzer sounds continuously, and the burner shuts OFF.
 - The SteamChef must be reset before cooking can continue.
2. If the SteamChef overheats and locks out while cooking, open the door and check if there is water in the reservoir.
 - If there is no water in the reservoir:
 - a. Turn OFF the SteamChef
 - b. Wait for the SteamChef to cool
 - c. Clean the water level probes
 - d. Reset the High Limit Lockout (See Step 3.)
 - e. Restart the SteamChef.
 - If there is water in the reservoir at the operating level:
 - a. Turn OFF the SteamChef and wait for the reservoir to drain.
 - b. Wait for the SteamChef to cool
 - c. Clean the water level probes
 - d. Reset the High Limit Lockout (See Step 3.)
 - e. Restart the SteamChef.
 - If the problem repeats, call your qualified Cleveland Range authorized service representative to adjust or repair the SteamChef.

3. **To Reset the High Limit Lockout:**

IMPORTANT: Do **NOT** add water to cool the SteamChef. This causes equipment damage.

- a. Turn OFF the ON/OFF lever.
- b. Open the cooking compartment door and wait for the SteamChef to cool.
- c. After the SteamChef is cool, check that the Water Level Sensor probes are clean.
- d. Press the High Limit Reset Button located on the bottom of the appliance about 3 inches from the control side and 4 inches from the front side. See Figure 3-4
 - If the button stays down, the SteamChef is cool enough to operate. Go to e).
 - If the button does not stay down, wait 5 more minutes and press it again.
 - 1) If the button stays down, go to e).
 - 2) If the button does not stay down, go to f).
- e. Replace the control side cover and restart the SteamChef. See “Power On” in Chapter 3.
- f. If the High Limit Lockout repeats:
 - 1) Replace the control side cover.
 - 2) Follow the Shutdown Instructions in Chapter 3.
 - 3) Call your qualified Cleveland Range authorized service representative.

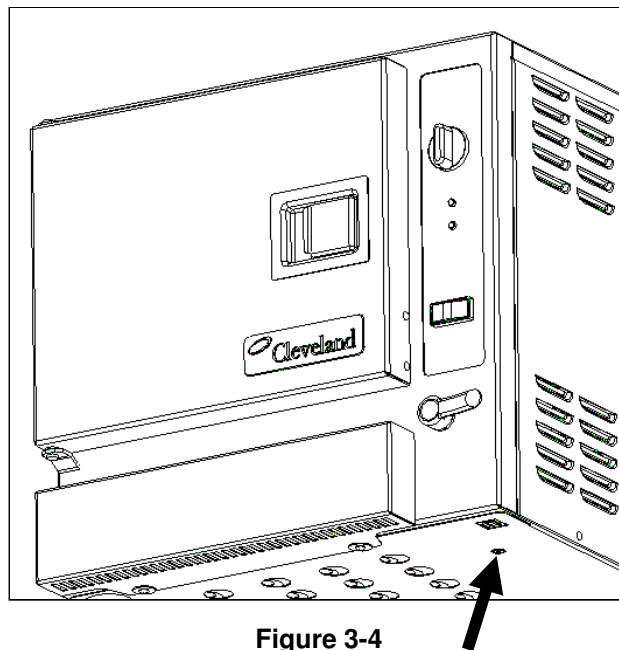

Figure 3-4
Reset Button Location

CHAPTER 4

CONTROL PANELS

⚠ CAUTION

Press switches and keys with fingertips only.
Injury and equipment damage can result from pressing switches and keys with anything else.

A. ON/OFF Control Panel

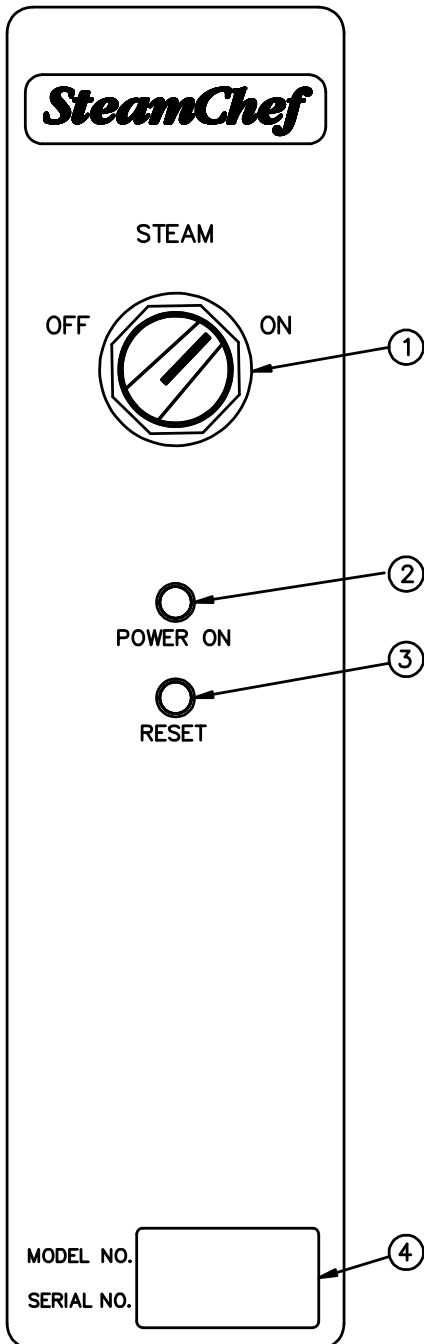

ON / OFF CONTROL PANEL

1. ON/OFF Switch.
Turn the ON/OFF Switch to start and stop steaming.
2. Power On Light
This light is lit when the electric power to the steamer is turned ON.
3. Reset Indicator Light
This light is lit when the SteamChef is overheated. It stays lit and a buzzer sounds until the steamer is Reset. See "High Limit Lockout" in Chapter 3.
4. Serial Number / Model Number Label.

Figure 3-7

B. Dial Timer Control Panel

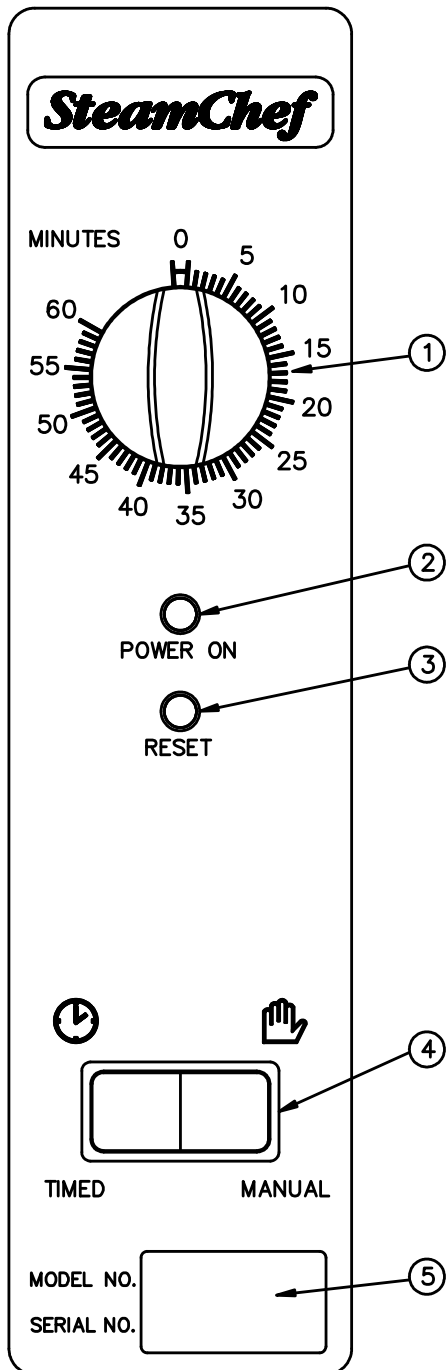

Figure 3-8

DIAL TIMER CONTROL PANEL

1. **Timer.**
This knob sets the operating time from 0 to 60 minutes. Turn the knob clockwise until it points to the required number of minutes. When it counts down to 0, a buzzer sounds for 3 seconds.
2. **Power ON Indicator Light.**
This light is lit when the electric power to the steamer is turned ON.
3. **Reset Indicator Light.**
This light is lit when the SteamChef is overheated. It stays lit and a buzzer sounds until the steamer is Reset. See "High Limit Lockout" in Chapter 3.
4. **Timed/Manual Switch.**
This switch selects the Timed or Manual operating mode. Manual mode has a fixed 60-minute timer. See "Operating and Cooking Procedure – Manual Mode" in Chapter 5.
5. **Serial Number / Model Number Label.**

C. Keypad Control Panel

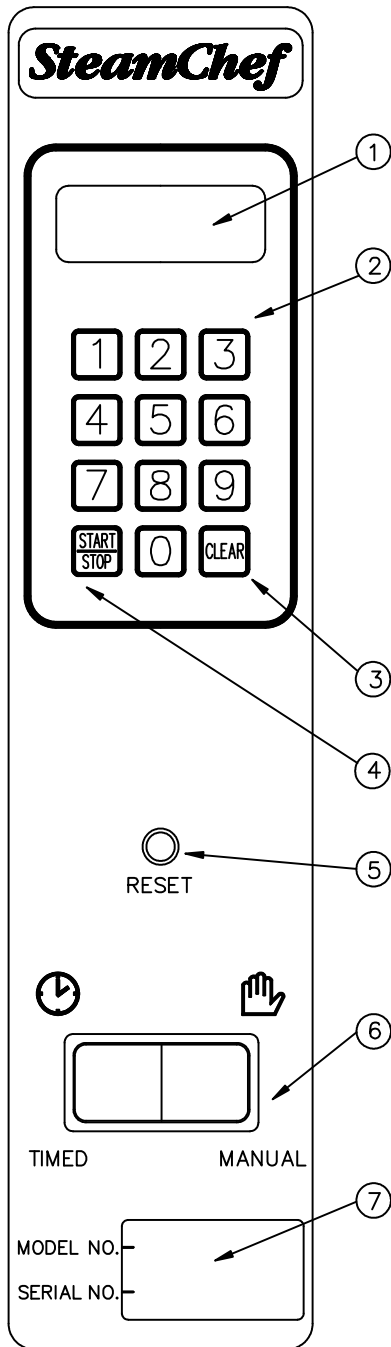

Figure 3-10

KEYPAD CONTROL PANEL

1. **Timer Display.**
The four-digit display shows minutes and seconds remaining in the countdown from the set time (99:99 to 00:00).
2. **Number Keys.**
Press the Number Keys to set the minutes and seconds required. (Pressing 1, 2, 3, 4 sets the Timer for 12 minutes and 34 seconds.)
3. **Clear Key.**
Press the Clear Key to stop the Timer. Press the Clear Key again for 3 seconds to reset the Timer to zero (00:00) before setting a new time.
4. **Start/Stop Key.**
The Start/Stop Key starts and stops the Timer.
5. **Reset Indicator Light.**
This light is lit when the SteamChef is overheated. It stays lit and a buzzer sounds until the steamer is Reset. See "High Limit Lockout" in Chapter 3.
6. **The Timed/Manual Switch**
This switch selects the Timed or Manual operating mode. Manual mode has a fixed 60-minute timer. See "Operating and Cooking Procedure – Manual Mode" in Chapter 5.
7. **Serial Number / Model Number Label.**

CHAPTER 5

COOKING WITH THE SteamChef

DANGER

**DO NOT BREATHE STEAM, HOT AIR OR CONDENSATE
DEATH OR INJURY WILL RESULT.**

WARNING

Hot Air, Steam, and Condensate will cause Burns and Scalds.

To help prevent burns and scalds when opening a steamer door: always stand to the hinge side and back from the door, slowly open the door, and wait for the steam and heat to dissipate before reaching into the steamer.

CAUTION

Some foods drip juices.

Use a solid catch pan under perforated pans when cooking food that drips juices.
Dripping juices can cause burns, and clog the drain and KleanShield™.

CAUTION

Do **NOT** use oven racks that are bent or otherwise damaged in any way.
DO Insert pans and accessories **LEVEL** and **INSIDE** the oven racks.
Pans and accessories placed in damaged or out of level racks, or outside racks can tip and spill, causing burns, injuries and/or equipment damage

WARNING

The SteamChef Steamer is a continuously operating appliance so parts are **ALWAYS HOT** when the main external power switch or the ON/OFF lever is in the ON position.
When the ON/OFF lever is turned to the OFF position, the SteamChef will remain HOT for some time.
Contact with hot surfaces and steam can cause burns and scalds.
Avoid contact with hot surfaces and steam.

WARNING

If the steamer door is stuck shut: DO NOT force the door open.
The door stuck shut may indicate a blocked drain.
Hot water can fill the cooking compartment and spill out if the door is forced open causing injury and equipment damage.

If the SteamChef door is stuck shut:

- Turn OFF the steamer.
- Call a qualified Cleveland Range authorized service technician.
- Wait for the steamer to cool before servicing.

A. Operating and Cooking Procedure – All Models

1. Before Cooking or Rethermalizing
 - a. See “To Inspect the Cooking Compartment” in Chapter 3. Inspect and clean the drain, KleanShield™, and cooking compartment as required.
 - b. See the “Power ON” instructions in Chapter 3, and turn ON and fill the SteamChef.
 - c. If necessary, see “To Preheat the SteamChef” in Chapter 3 and preheat the cooking compartment.
 - d. Slide the pans of food into the slide racks inside the SteamChef. Do not place pans or anything else on the bottom of the compartment or on the KleanShield™.
 - e. For best results, use 2-1/2 inch deep, perforated pans without covers. These give the best heat transfer and shortest cooking time.
 - f. Close the SteamChef door.
2. While cooking, occasionally check the water in the reservoir for food particles and oils. If the water is dirty, change the water. See Chapter 7.
3. After Cooking or Rethermalizing
 - a. Carefully open the cooking compartment door and remove the pans from the slide racks.
 - b. If the SteamChef will not be used again, shut it down and perform the Cleaning Procedure in Chapter 6.

B. Operating and Cooking Procedure – Timed Mode

In Timed Mode, the Timer starts and stops the cooking operation. When in the Timed Mode and the compartment door is closed, and the Timer is NOT set, the SteamChef will maintain the compartment at the operating temperature.

1. Check the control panel settings. The settings should be:
 - The ON/OFF Lever is in the ON (down) position and the Power indicator light is lit.
 - The TIMED/MANUAL switch is in the TIMED position.
2. Set the required cooking time. The Timer starts counting down.
3. When the Timer reaches zero, a buzzer sounds for 3 seconds; the convection fan turns OFF and the SteamChef will revert to standby mode. The cooking cycle is complete.

Note: The compartment temperature is automatically maintained at operating temperature.

C. Operating and Cooking Procedure – Manual Mode

The operator starts and stops the steaming operations, and controls the cooking time, including cooking compartment heat-up time.

Note: The SteamChef has an Energy Saver Feature that automatically switches to standby mode after 60 minutes of operating in Manual Mode without interruption (e.g. opening the door).

Note: If cooking times longer than the 60 minutes are desired, it is necessary to reset the Timer. To reset the Timer without interrupting the cooking, quickly open and close the cooking compartment door.

Note: The compartment temperature is automatically maintained at operating temperature between batches.

1. Check the control panel settings. The settings should be:
 - The ON/OFF Lever is in the ON (down) position and the Power indicator light is lit.
 - The TIMED/MANUAL selector switch is in the MANUAL position. The steaming cycle starts as soon as the switch is moved to MANUAL.
2. To stop steaming in Manual Mode: set the selector switch to the TIMED position and verify that the Timer is at zero. The burner turns off, and steam flow to the cooking compartment gradually stops.

D. Operating and Cooking Procedure – ON/OFF Control Panel

- The operator starts and stops steaming operations.
- The operator preheats or reheats the SteamChef.
- When turned ON, cooking with the SteamChef is the same as cooking with a Dial Timer Control SteamChef in the Manual Mode with a fixed 60-minute timer.
- For longer cooking times, switch OFF and back ON to reset the fixed 60-minute timer.
- When turned OFF, the SteamChef reverts to standby mode.

E. Operating Procedure – Rethermalization

The SteamChef may also be used to reheat/rethermalize previously cooked and/or refrigerated foods to serving temperature.

Depending on initial food temperature and density, most foods will rethermalize to their safe serving temperature in 10 to 40 minutes.

To use the SteamChef to reheat/rethermalize food to a safe serving temperature.

1. Always check internal temperature of food with a thermometer to determine that it has been rethermalized to its safe serving temperature.
2. Remember that the SteamChef has an **Energy Saver Feature**. This automatically switches the cooking compartment to the standby mode after an hour of operating in the Manual Mode without interruption.
3. If rethermalizing times longer than the 60 minutes are required, resetting the Timer is necessary.
 - To reset the Timer without interrupting the continuous operation of the SteamChef, quickly open and close the cooking compartment door.

CHAPTER 6

CLEANING the SteamChef

Cleaning Procedure

The cleaning procedure should be performed at the end of each day or shift, or more frequently if the water supply does not meet the Minimum Water Quality Requirements described in the Warranty in this manual and in the Installation Manual.

WARNING

The steamer stays hot for a long time.
To help avoid burns: Allow the steamer to cool completely before cleaning or servicing.

WARNING

Do NOT use hoses, power cleaners, or pressure washers on or in the SteamChef Steamer.
Doing so can cause electric shock and / or damage electrical and electronic components.

WARNING

A clogged or slow drain can cause hot water to collect in the oven compartment and spill out when the door is opened causing injury and equipment damage.

Never push food debris or scale down the steamer drain, or through the KleanShield™ opening. Debris and scale can build up in the drain system and clog or slow the drain and lead to additional maintenance and service problems.

Always remove any solid matter from the inside of the steamer with a rag or spatula before rinsing cleaning water down the drain.

WARNING

When cleaning: do NOT pick up or tilt the SteamChef. If it is necessary to move a SteamChef for cleaning, turn OFF power at the Main External Power Supply and at the ON/OFF Lever to drain the water from the SteamChef.

Injury and equipment damage can result from shifting the SteamChef out of level while the power is turned on at the Main External Power Supply and/or water is in the SteamChef .

The steamer MUST BE LEVEL BOTH FRONT TO BACK AND SIDE TO SIDE in all mounting arrangements before operation. Check level front to back and side to side before restoring power as described in the Installation Manual after moving the SteamChef.

Failure to do so can cause injury and equipment damage.

Cleaning Procedure (Continued)

Daily cleaning will help prevent the buildup of calcium and other mineral deposits (“scale”) left by boiling water, and help prevent more costly maintenance and service on the SteamChef.

NOTICE: Do NOT use abrasive cleaning compounds or steel wool.

1. Turn the ON/OFF lever OFF (counter-clockwise) See Figure 3-3. The SteamChef will begin a 3-minute drain rinse cycle to clean the drain system.
2. Open the SteamChef door and allow SteamChef to cool.
3. Remove any spilled food from the surface of the KleanShield™.
4. Remove the slide racks, air diverter, fan guard, and KleanShield™. Wash and rinse slide racks, air diverter, fan guard, and KleanShield™ separately or clean them in a dishwasher according to health requirements.
5. Remove any spilled food from inside compartment and clear any residue from the drain valve and the KleanShield™ drain opening.
6. Clean the interior of the compartment thoroughly, removing all food particles and scale.
7. Do NOT push food scraps, debris, or scale down the reservoir drain, or down the KleanShield™ drain.
8. Wipe the interior of the cooking compartment with half water and half white household vinegar solution.
9. Use a spray bottle of the same vinegar solution to rinse the convection fan blade located at the back of the cooking compartment.
10. Use a soft bristle brush to clean the water probes and fan, and to remove stubborn food particles.
11. Cleveland Range does not recommend the use of detergent, but if detergent has been used to clean the inside of the SteamChef, be sure to rinse off the probe assembly with the vinegar solution. If detergent residue is not completely rinsed from the probe assembly then the residue can prevent the water level control from operating.
12. Rinse the inside of SteamChef compartment and drain valve thoroughly with clean water.
13. Clean the door assembly.
 - a. Remove the door gasket assembly. See Figure 4-1.
 - b. Note the keyhole slots on the door and the retaining pins on the gasket assembly. Grasp the gasket assembly at the sides and lift up and towards you to remove the assembly.
 - c. Clean all surfaces of the gasket assembly, as well as the inside of the door, by wiping with a damp cloth.
 - d. Rotate the liner assembly 180° and replace the gasket assembly by sliding the retaining pins into the keyhole slots. Either long edge of the gasket assembly can be positioned at the top. Periodic rotating of the door assembly will help increase the door gasket life.
14. Replace the cleaned KleanShield™, fan guard, and slide racks.
15. Wipe the exterior with a damp cloth only.
16. NEVER HOSE DOWN THE STEAMCHEF. Electrical and electronic components of the SteamChef will not function correctly if wet or damp and may cause a shock hazard.
17. After cleaning, leave the SteamChef door open until the next use. This prevents compartment odor buildup and increases gasket life.

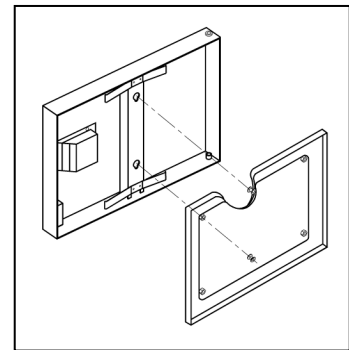

Figure 4-1 Door Gasket Assembly

CHAPTER 7

PREVENTATIVE MAINTENANCE and TROUBLESHOOTING

A. Maintenance

Maintenance on the SteamChef must be performed on a regular basis to keep the SteamChef operating properly and efficiently. Following the maintenance instructions in this chapter and cleaning the equipment regularly as outlined in Chapter 6 help keep problems with the SteamChef to a minimum. The frequency of SteamChef maintenance may need to be increased depending on equipment usage and water quality. If problems occur, refer to the Troubleshooting Guide in this chapter. For more information on products and services, contact your sales representative.

1. Maintenance Records

Make a file for maintenance and repair records only. Keep a written record of daily, weekly, monthly, and yearly maintenance. These records will help protect warranty coverage, help schedule maintenance procedures, help keep the SteamChef cooking properly, and assist service personnel.

2. Daily Maintenance

a. Checking and Changing the Water

When using the SteamChef check the water often to make sure it is clean, especially if cooking with perforated pans. Although most food drippings will be caught by the KleanShield™, the water may become dirty from spilled food falling over the edge of pans when loading, cooking, and unloading. Change the water (see below) when the water becomes cloudy or contaminated with food particles.

- **CHANGE THE WATER IN THE STEAMCHEF AT LEAST EVERY DAY IN ORDER TO HELP MAINTAIN FOOD QUALITY AND HELP KEEP THE STEAMCHEF SANITARY.**
- **Note:** It may be necessary to change the water several times a shift, especially when cooking strong flavored or starchy foods or using perforated pans.

b. To Change the Water in the Reservoir:

- Turn OFF the ON/OFF lever/switch and let the drain rinse cycle run. Turn ON to refill. Repeat the drain and refill one more time. If the water is clean, resume cooking as usual.
- If the water is not clean after two rinses, go to the Cleaning Procedure in Chapter 6.

3. Scheduled Cleaning of the SteamChef

- Clean interior and exterior of the SteamChef according to the Shutdown Instructions in Chapter 3 and the Cleaning Instructions in Chapter 6, least once per day or at the end of each shift.

4. Yearly Maintenance – Cleaning the Filter Washers (Dirt Filter, Strainer)

Clean the water line filter washers at least once a year as follows:

Note: When the SteamChef is first installed, check the filter washer more frequently to find out how often the strainer must be cleaned.

Note: Do NOT use pipe dope or pipe tape on GHT fittings.

- Turn OFF power to the SteamChef at the Main External Power Switch.
- Close the valves in the SteamChef water supply lines.
- Remove the water supply lines (hoses) from the GHT inlet fittings located on the rear of the SteamChef.
- Remove the filter washers from the GHT inlet fittings and wash them with clean water. See Figure 5-1.
- Check the filter washers for wear and replace them if necessary.
- Put a filter washer into each of the water inlets and reconnect the water supply lines (hoses) to the GHT inlet fittings on the back of the SteamChef.
- If treated water is used to supply water to the reservoir, make sure that it is connected to the LOWER water inlet at the rear of the SteamChef.
- Open water supply valve(s) and check for water leaks.
- Turn the power ON to the SteamChef at the Main External Power Switch.

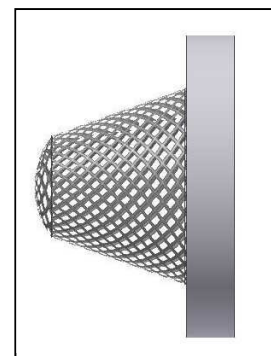

Figure 5-1 Filter Washer Assembly (P/N 110987)

5. Other Maintenance – Periodic Descaling of the Water Reservoir

NOTICE: Cleveland Range recommends that only qualified Cleveland Range authorized technicians or trained onsite maintenance personnel perform this service.

- a. Is Descaling Necessary?
 1. Although, a SteamChef should not normally require descaling, the use of “hard” water or failure to follow the vinegar cleaning procedures in Chapter 6 may cause the accumulation of scale in the SteamChef.
 2. Scale can deposit in the bottom of the SteamChef reservoir and/or in its drain. Descaling can help prevent a costly service call if scale buildup begins to impair the SteamChef’s operation.
 3. Descaling is not normally required on a SteamChef. Frequency will depend on the local water quality, and the frequency of shutdown and cleaning of the water reservoir as described in Chapter 3.
 4. The frequency of descaling must be determined by the owner and performed by qualified Cleveland Range authorized technicians, or trained onsite maintenance personnel.
- b. If descaling is necessary, Cleveland Range recommends the use of DISSOLVE® Descaler Solution, Cleveland Range Part No. 106174. No other system of descaling should be used.
Note: Part No. 106174 is the Part No. for a case (6 1-gallon containers) of DISSOLVE® descaler.
- c. Call Cleveland Range at 216-481-4900 or 1-800-338-2204 if any questions arise.
- d. To descale the SteamChef 22CGT3 and 22CGT6:

DANGER!

The liquid solution in Cleveland Range Descaler Solution Part No. 106174 can be harmful if not handled properly. Follow these basic safety rules for handling and using this product. Instructions and warnings on container labels supercede all other warnings and instructions.

Wear protective clothing when mixing or applying chemical cleaners

Wear rubber gloves, and OSHA approved eye protection when descaling

Avoid breathing fumes

If liquid contacts skin: wash with soap and water

If chemical contacts eyes: flush with water and seek medical attention

If chemical is swallowed or ingested: drink 1 or 2 glasses of water and seek medical attention

FAILURE TO DO SO CAN CAUSE DEATH OR INJURY

WARNING

Descaling procedure is slightly different depending on model. This entire procedure must be read and fully understood as it applies to the model being descaled, before beginning descaling operations. Failure to do so can cause injury and equipment damage.

CAUTION

Do not use any other product or method of descaling other than the *DISSOLVE*® Descaler method using Part No. 106174. Failure to do so can cause injury and equipment damage.

- Cleveland Range recommends DISSOLVE® Descaler Solution, Part No. 106174.
- Use no other system of steamer descaling
- Appropriate warnings and safe handling procedures must be provided to handlers and users
- Instructions and warnings on Dissolve® containers and Material Safety Data Sheets supercede and replace instructions and warnings in this manual
- General precautions: wear rubber gloves, splash goggles and other protective clothing and equipment as necessary. Refer to Dissolve® container labels and Material Safety Data Sheets for information regarding eyewash, first aid, medical treatment, and spill control.

MODEL 22CGT3.1 and 22CGT6.1, BOILERLESS STEAMER DESCALING PROCEDURE for DISSOLVE® Descaler Solution Part No. 106174.

- The entire procedure must be read and fully understood before beginning descaling.
 - This procedure takes about 1 hour 30 minutes to complete.
 - Repeat this procedure as needed for heavy scale buildup.
 - Regular cleaning of the steamer with vinegar per the instructions found in Chapter 6 may help reduce need for descaling.
 - Sides, back, and top of steam compartments may be descaled with a vinegar solution and a soft brush. See Chapter 6.
- 1) Open the door to the cooking compartment.
 - 2) Set the TIMED/MANUAL switch to TIMED **OR** the ON/OFF switch to OFF.
 - 3) Set the ON/OFF lever to the OFF position.
 - The 3-minute drain rinse cycle starts.
 - 4) Remove the Pan Racks and KleanShield™ from inside the steamer.
 - Heavily scaled pan racks and KleanShield™ may be descaled by soaking them in a solution of 1 part Dissolve® and 4 parts water, rinsing thoroughly with cold water, and washing them in a dishwasher.
 - 5) Remove any loose scale from the bottom of the steamer.
 - 6) When the drain cycle is done, turn the ON/OFF lever to ON to refill the unit.
 - 7) Do not start the timer.
 - 8) Leave the door open.

NOTE: DO NOT HEAT THE STEAMER DURING DESCALING.

- 9) While the reservoir is filling with water, pour 1 to 1 ½ quarts (about a third of a 1-gallon bottle) of DISSOLVE® descaler solution into the water reservoir.
 - While adding DISSOLVE® descaler to the reservoir, pour it in slowly to avoid splashing the liquid or overflowing the reservoir.
- 10) After automatic fill ends, turn OFF the Main External Power Switch. See Figure 3-1.
- 11) Leave the door open and let the DISSOLVE® work for 1 hour.
- 12) At the end of 1 hour, set the ON/OFF lever to the OFF position.
- 13) Turn the power ON at the Main External Power Switch.
- 14) After the 3-minute drain cycle completes, turn the ON/OFF lever back ON. (NOTE: If the reservoir does not fill, dry off the water probe assembly).
- 15) After filling stops, add 1/2 gallon of water to the reservoir. Do not overflow the reservoir.
- 16) Turn the ON/OFF lever OFF to start the drain cycle.
- 17) After the reservoir drains, set the ON/OFF lever to the ON position to refill the reservoir.
- 18) Close the cooking compartment door and set the timer for 20 minutes (ON/OFF Control Models: set the control to ON.). The steamer heats to normal operating temperature.
- 19) After 20 minutes turn OFF ON/OFF controls and turn the ON/OFF lever to OFF.
- 20) The 3-minute drain cycle starts.
 - This is the final rinse of the reservoir.
- 21) If the reservoir drains slowly even after being descaled, turn OFF the steamer and clean the drains with a NSF approved drain cleaner.
- 22) Once the scale is removed and the drain flows freely, the steamer is ready for normal operation.

B. Operator's Troubleshooting Guide

The Troubleshooting Guide is a list of symptoms of problems that may be encountered during operation.

- "Problem" (left column) lists common operating problems.
- "Possible Cause" (center column) lists causes of problems in order they should be checked.
- "Remedy / Reference" (right column) lists fixes for problems from easiest to hardest.
- "Notes" in "Remedy / Reference" column are at end of Table 3-1 Troubleshooting Guide.

ATTEMPTING TO REPAIR OR CORRECT PROBLEMS REQUIRING AN AUTHORIZED SERVICE REPRESENTATIVE VOIDS WARRANTY

Table 3-1 Troubleshooting Guide

PROBLEM	POSSIBLE CAUSE	REMEDY/REFERENCE
Power indicator light does not turn ON when ON/OFF lever is in the ON position.	Power turned OFF at main external power switch.	Turn ON power at main external power switch.
	ON/OFF lever not fully turned to the ON position.	Turn lever to the ON position.
	Inoperative controls or indicators.	See Note 1
Power ON and SteamChef does not fill	Water supply to SteamChef shut OFF	Open water supply lines.
	Water line strainer and/or external filter system clogged.	Clean water supply strainer and/or filter system. See Yearly Maintenance in Chapter 7
	Gas Supply is turned OFF.	Turn gas supply ON.
	Water sensor is grounded by detergent film, or scale.	Rinse water sensor assembly thoroughly with vinegar solution, as described in Chapter 6, Shutdown and Cleaning Procedure.
	Inoperative controls or solenoids.	See Notes 1 and 5

(Continued on Next Page)

Troubleshooting Guide(Continued)

PROBLEM	POSSIBLE CAUSE	REMEDY/REFERENCE
Control panel power indicator light ON, and SteamChef does not come up to cooking temperature or produce steam.	Door interlock switch not engaged.	Close door completely.
	Water supply to SteamChef shut OFF	Open water supply lines.
	Water line strainer and/or external filter system clogged.	Clean water supply strainer and/or filter system. See Yearly Maintenance in Chapter 7.
	SteamChef is in the Timed Mode and Timer is not set. (Dial Timer control models only.)	Change to Manual Mode or set the Timer.
	High limit switch has tripped.	Reset the SteamChef according to instructions found in Chapter 3 If the condition repeats, see Note 1.
	Inoperative controls.	See Note 1.
Control panel POWER indicator light ON and SteamChef does not make steam in MANUAL or TIMED Modes.	Water supply to SteamChef shut OFF.	Open water supply valves.
	Door interlock switch not engaged or has failed.	Close door completely. If problem persists, see Note 1.
	Water line strainer and/or external filter is clogged.	Clean water supply strainer and/or external filter system.
	Gas supply valve is closed.	Open gas supply valve.
	Inoperative controls or solenoid.	Reset the SteamChef according to instructions found in Chapter 3 If the condition repeats, see Note 1.
Control panel Power indicator is on, buzzer is buzzing continuously, and Reset indicator is lit.	High limit has tripped.	See Note 1.
	Inoperative controls.	See Note 1.
Control panel Power indicator is on, buzzer is buzzing continuously.	Burner has failed to light.	Reset the SteamChef according to instructions found in Chapter 3, "Lighting Instructions". See Note 1.
Compartment bottom dirty with food drippings.	Juices and/or food leaking from pans during loading and unloading of the SteamChef.	Put a solid pan under perforated pans to catch drippings. Put less food in pan.
	KleanShield™ not installed.	Install KleanShield™ to catch food drippings.
Abnormal amount of steam coming from drain during draining of SteamChef	ON/OFF lever not all the way OFF.	Turn ON/OFF lever all the way OFF to start the 3-minute drain rinse cycle.
	Water line strainer and/or external filter system clogged.	Clean water supply strainer and/or filter system.
	3-minute drain rinse timer defective.	Call for service. See Note 1.
	Hot water instead of cold water connected to reservoir fill line.	See Note 2 and 3.
	Inoperative controls.	Call for service. See Note 1.
	The KleanShield™ drain or the main drain is clogged or covered.	Clear the drain opening and/or clean the drain with NSF approved drain cleaner and flush drain thoroughly with fresh water. If condition persists, see Note 1.
Steam and/or water draining around the compartment door. See Warning under Note 7.	Door gasket or door parts worn.	Call for service. See Note 1.
	Hot water instead of cold water connected to the condenser water line.	See Notes 1, 2 and 3.

(Continued on Next Page)

**Troubleshooting Guide
(Continued)**

PROBLEM	POSSIBLE CAUSE	REMEDY/REFERENCE
Steam and/or water draining around the compartment door. See Warning under Note 7.	External drain not properly sized, installed, free air vented, and/or pitched down.	Verify drain sized and installed properly. See the Installation Manual See Notes 2 and 3.
	SteamChef not level.	See Note 2.
	Drain is blocked.	Clean drain with NSF approved drain cleaner. If condition persists, see Note 1.
	Inoperative controls.	See Note 1.
Steam coming out of the drain.	A small amount of steam may issue from the drain whenever the SteamChef is in the cooking mode.	This is normal operation of the SteamChef NO action is necessary.
Abnormal amount of steam coming from drain	Condenser water supply is turned OFF.	Turn ON condenser water supply.
	Hot water instead of cold water connected to the condenser water line.	See Note 2 and 3.
	Condenser water line strainer clogged.	Clean water supply strainer. See Yearly Maintenance in Chapter 7.
	Inoperative controls.	See Note 1.
Food takes too long to cook.	Pans too close to the bottom of the cooking compartment.	Put pans in racks near the top of the cooking compartment.
To verify the SteamChefs proper operation see Note 8.	Compartment overloaded with too much food.	Put less food into pans. Use fewer pans.
	Suggested cooking times are usually listed for cooking at sea level.	Extend cooking times for altitudes above 2500 feet.
	Convection fan inoperative.	See Note 1.
	Bottom of SteamChef is scaled.	See Note 9.
	Inoperative controls.	See Note 1.

Troubleshooting Notes

1. Repairs must be made or maintenance must be done by a qualified Cleveland Range authorized service technician. Cleveland Range will not pay for warranty repairs or maintenance by other than qualified Cleveland Range authorized service technicians or service centers.
2. Proper installation of the SteamChef is the responsibility of the owner or installer. A qualified Cleveland Range authorized installer or technician must be contacted to correct the installation
3. Repairs to external plumbing must be done by a Licensed Plumber.
4. Repairs to external wiring must be done by a Licensed Electrician.
5. If the automatic fill system fails for any reason, the SteamChef will stop heating when the water level drops below the minimum operating level. Should this happen, the SteamChef can continue to be operated by manually filling the water reservoir with a gallon of water about every half-hour, until service can be performed. Actual volume of water and time between fill-ups may vary.
6. Call the Cleveland Range Service Department at 216-481-4900 for assistance designing a preventative maintenance program and water treatment system.

(Troubleshooting Notes Continued on Next Page)

7. Whenever opening door, especially when water or steam is leaking around gasket follow the warning below.

⚠ WARNING
Water and/or steam leaking from the door gasket can be a sign of a blocked drain. If the drain is blocked, hot water and steam can accumulate inside the compartment and spill out when the door is opened and cause injury and equipment damage. When checking inside the steamer always stand to the hinge side and back from the steamer and open the door slowly.

8. To evaluate whether a SteamChef is at normal performance: conduct the Egg Test. (Note: this test is not valid for pressure steamers). A properly operating SteamChef will produce perfect hard-boiled eggs.
- a. Turn on the SteamChef in Manual Mode, or for ON/OFF models set the selector to the ON position. Preheat the SteamChef for 10 minutes.
 - b. After preheating:
 - 1) Place a fresh egg on a perforated steam table pan in the middle of the oven compartment.
 - 2) Close the door and set the Timer as directed by the Egg Test Size Chart.
 - 3) Carefully remove the egg and place in a container with cold water running over it.
 - 4) Let the egg cool under cold running water for 5 minutes.
 - 5) After cooling, crack peel off the eggshell.
 - 6) The result is a perfect hard-boiled egg.

Egg Test Size Chart

Egg Size	SteamChef
Medium	16 minutes
Large	18 minutes
Extra Large	18 minutes

9. Although, a SteamChef should not normally require descaling, the use of extremely “hard” water or failure to follow consistently the cleaning procedures outlined in the Shutdown and Cleaning Instructions in Chapter 3 may cause the accumulation of scale in the SteamChef. Should this occur the supplementary descaling procedure outline in Chapter 7 “Other Maintenance – Periodic Descaling of Water Reservoir” may be necessary. Notice: only qualified Cleveland Range authorized technicians or trained onsite maintenance personnel may perform this service.