

Operator's Manual

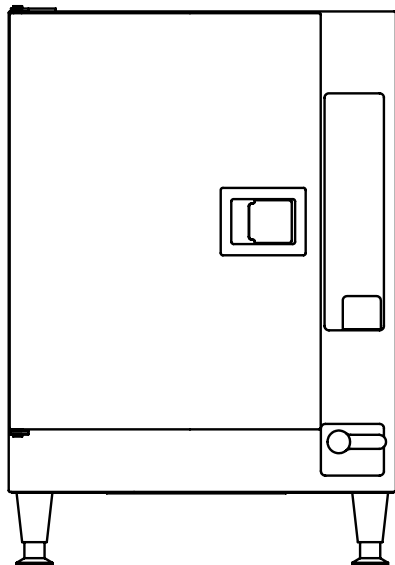

PATENT PENDING

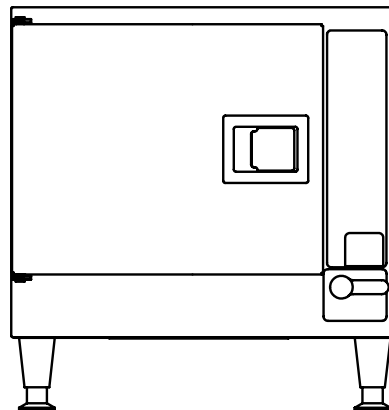

Energy Star SteamChef Models 22CET3.1 and 22CET6.1

1333 East 179th Street
Cleveland, Ohio 44110

Phone: (216) 481 - 4900
1-800-338-2204

Fax: (216) 481 - 3782
www.clevelandrange.com



Cleveland

Part No. 22CET(ES)-OPM REV. C 5/07

FOR YOUR SAFETY

Do not store or use gasoline or other flammable vapors or liquids in the vicinity of this or any other appliance.

⚠ WARNING

Improper installation, adjustment, alteration, service or maintenance can cause property damage, injury or death. Read the installation, operating and maintenance instructions thoroughly before installing or servicing this equipment.

⚠ DANGER

ELECTRIC SHOCK HAZARD

DEATH, INJURY, or EQUIPMENT DAMAGE can result from touching any component inside this appliance when the power is connected.

Whenever possible disconnect the power while installing, servicing, or testing.

When installation, service, or tests require power to be connected; use extreme caution and every possible precaution and safety measure while installing, servicing, or testing this appliance.

⚠ WARNING

Do not connect the drain connection to any drain material that cannot sustain 180° Fahrenheit.

Using drain material that cannot withstand 180° Fahrenheit can result in injury, equipment damage, and property damage.

⚠ WARNING

The SteamChef Steamer is a continuously operating appliance so parts are **ALWAYS HOT** when the main external power switch or the ON/OFF lever is in the ON position.

When the ON/OFF lever is turned to the OFF position, the SteamChef will remain HOT for some time.

Contact with hot surfaces and steam can cause burns and scalds.

Avoid contact with hot surfaces and steam.

**ALL SERVICE MUST BE PERFORMED BY A QUALIFIED
CLEVELAND RANGE AUTHORIZED TECHNICIAN
KEEP THIS MANUAL FOR REFERENCE**

This manual may be subject to new technical developments, modifications, and unforeseen errors.

DO NOT INSTALL OR OPERATE OR ATTEMPT TO INSTALL OR OPERATE THIS APPLIANCE OR ANY ACCESSORIES WITHOUT READING COMPLETELY AND FULLY UNDERSTANDING THIS MANUAL

Cleveland Range appliances are intended for other than household use.

Cleveland STATEMENT OF POLICIES

LIMITED WARRANTY

CLEVELAND RANGE products are warranted to the original purchaser to be free from defects in materials and workmanship under normal use and service for the standard warranty period of one year from date of installation or 18 months from date of shipment, whichever comes first.

CLEVELAND RANGE agrees to repair or replace, at its option, f.o.b. factory, any part which proves to be defective due to defects in material or workmanship during the warranty period, providing the equipment has been unaltered, and has been PROPERLY INSTALLED, MAINTAINED, AND OPERATED IN ACCORDANCE WITH THE CLEVELAND RANGE OWNER'S MANUAL.

CLEVELAND RANGE agrees to pay any FACTORY AUTHORIZED EQUIPMENT SERVICE AGENCY (within the continental United States, and Hawaii) for reasonable labor required to repair or replace, at our option, f.o.b. factory, any part which proves to be defective due to defects in material or workmanship, during the labor warranty period. This warranty includes travel time not to exceed two hours and mileage not to exceed 50 miles (100 miles round-trip), BUT DOES NOT INCLUDE POST START-UP, TIGHTENING LOOSE FITTINGS, MINOR ADJUSTMENTS, MAINTENANCE, CLEANING OR DESCALING.

The standard labor warranty allows factory payment of reasonable labor required to repair or replace such defective parts. Cleveland Range will not reimburse the expense of labor required for the repair or replacement of parts after the standard warranty period, unless an Extended Labor Warranty Contract has been purchased to cover the equipment for the balance of the warranty period from the date of equipment installation, start-up, or demonstration.

PROPER INSTALLATION IS THE RESPONSIBILITY OF THE DEALER, THE OWNER-USER, OR INSTALLING CONTRACTOR, AND IS NOT COVERED BY THIS WARRANTY. Many local codes exist, and it is the responsibility of the owner and installer to comply with these codes. Cleveland Range equipment is built to comply with applicable standards for manufacturers, including UL, ANSI, NSF, ASME/Ntl. Bd., CSA, and others.

BOILER (Steam Generator) MAINTENANCE IS THE RESPONSIBILITY OF THE OWNER-USER AND IS NOT COVERED BY THIS WARRANTY. The use of good quality feed water is the responsibility of the Owner-User (see Water Quality Recommendations below). THE USE OF POOR QUALITY FEED WATER WILL VOID EQUIPMENT WARRANTIES. Boiler maintenance supplies, including boiler hand hole gaskets, are not warranted beyond the first 90 days after the date the equipment is placed into service. Preventive maintenance records must be available showing descaling per applicable Cleveland Operator Manual for Boiler Proration Program considerations.

WATER QUALITY RECOMMENDATIONS

TOTAL DISSOLVED SOLIDS	less than	60 parts per million
TOTAL ALKALINITY	less than	20 parts per million
SILICA	less than	13 parts per million
CHLORIDE	less than	30 parts per million
pH FACTOR	greater than	7.5

The foregoing shall constitute the sole and exclusive remedy of original purchaser and the full liability of Cleveland Range for any breach of warranty. THE FOREGOING IS EXCLUSIVE AND IN LIEU OF ALL OTHER WARRANTIES, WHETHER WRITTEN, ORAL, OR IMPLIED, INCLUDING ANY WARRANTY OF PERFORMANCE, MERCHANTABILITY, OR FITNESS FOR PURPOSE, AND SUPERSEDES AND EXCLUDES ANY ORAL WARRANTIES OR REPRESENTATIONS, OR WRITTEN WARRANTIES OR REPRESENTATIONS, NOT EXPRESSLY DESIGNATED IN WRITING AS A "WARRANTY" OR "GUARANTEE" OF CLEVELAND RANGE MADE OR IMPLIED IN ANY MANUAL, LITERATURE, ADVERTISING BROCHURE OR OTHER MATERIALS.

CLEVELAND RANGE'S liability on any claim of any kind, including negligence, with respect to the goods or services covered hereunder, shall in no case exceed the price of the goods or services, or part thereof, which gives rise to the claim. IN NO EVENT SHALL CLEVELAND RANGE BE LIABLE FOR SPECIAL, INCIDENTAL, OR CONSEQUENTIAL DAMAGES, OR ANY DAMAGES IN THE NATURE OF PENALTIES.

LIMITED EXTENDED WARRANTY COVERAGE

The purchase of a Limited Extended Warranty Contract extends the standard warranty coverage to the purchased period of time (one to two years) from the date of installation, start-up, or demonstration, whichever is sooner.

*An additional two years Parts and Labor Warranty can be purchased with each piece of Cleveland equipment for an additional 2% of the List Price per year. The 2% of list price charge will be the net invoice amount for each year of extended warranty purchased.

- Extended warranty must be purchased at the same time the equipment is purchased.
- Extended Warranty has the same exclusions as stated in our standard warranty.

Second year limited extended warranty coverage on Cleveland Steamers when purchased with a water filter applies to water related components only.

Free Start-Up Program

Get the most from your Cleveland Range equipment with Cleveland Range's "Free Start-Up."

Performance Check-Out: Contact your Cleveland Range maintenance and repair center for your Performance Check-Out before starting your new Cleveland Range Steamer.

The Performance Check-Out includes:

Inspection of the Installation
Review of Cleaning Procedures
Review of Maintenance Procedures
Start of Warranty Protection

Equipment Demonstration: After your Performance Check-Out, contact your Cleveland Range sales representative for your free Equipment Demonstration.

The Equipment Demonstration includes:

Proper Operation
Optimized Use
Care, Cleaning, and Maintenance

To arrange for your free Start-Up Program appointment consult your Customer Service Directory or call Cleveland Range at:

216-481-4900

OR

1-800-338-2204

Ask your sales representative for more information about uses for your new appliance.

OPERATOR'S MANUAL
SteamChef Models 22CET3.1 and 22CET6.1
Table of Contents

Chapter.....	Page
1 General Safety	1
A. Laws, Codes, and Regulations	1
B. Operational Safety.....	1
2 Product Information	3
A. Product Information	3
B. Model Numbers and Serial Numbers	3
C. Product Information Plate	3
D. Product Views.....	4
3 Operation	5
A. Main External Power Switch	5
B. Door Interlock Switch	5
C. Inspect the Cooking Compartment	5
D. Install/Remove the Slide Racks (Pan Racks).....	6
E. Install/Remove the KleanShield™	6
F. Install the Fan Guard and Air Diverter	7
G. Power ON (Auto Water Fill / Automatic Preheat).....	8
H. Preheat the Steamer.....	8
I. High Limit Reset.....	8
4 Control Panels	9
A. Keypad Timer Control Panel	9
B. Dial Timer Control Panel.....	10
C. ON/OFF Control Panel	11
5 Cooking with the SteamChef	12
A. Operating and Cooking Procedure – All Models.....	13
B. Operating and Cooking Procedure – Timed Mode	13
C. Operating and Cooking Procedure – Manual Mode.....	13
D. Operating and Cooking Procedure – ON/OFF Control Panel	14
E. Operating and Cooking Procedure - Rethermalization	14

6 Shutdown and Cleaning	15
A. Shutdown and Cleaning Procedure	15
7 Preventative Maintenance	17
A. Maintenance	17
B. Descale the Water Reservoir	18
8 Operator’s Troubleshooting Guide	21

CHAPTER 1 SAFETY

A. Laws, Codes, and Regulations

This equipment should be installed only by qualified, professional plumbers, pipe fitters, and electricians.

1. The installation of this appliance must conform with:
 - a. The National Electrical Code, ANSI/NFPA 70 (latest edition), or the Canadian Electrical Code, CSA C22.2, or local codes, as applicable.
 - When installed, the appliance must be electrically grounded in accordance with the above.
 - NOTE: This appliance is not GFI (GFCI) compatible.
 - b. The *Food Code* (latest edition) of the Food and Drug Administration (FDA).
2. This equipment is to be installed to comply with the applicable federal, state, or local plumbing codes.
3. Installation instructions must be read in their entirety before starting installation of this appliance.
4. Install this appliance according to the policies and procedures outlined in this manual.
5. Installation must comply with all local fire and health codes.

DANGER

Improper installation, adjustment, alteration, service, or maintenance of this appliance, or installation of a damaged appliance can result in DEATH, INJURY, EQUIPMENT DAMAGE, and void the warranty. **NEVER** install damaged appliances, equipment, or accessories. **ALWAYS** have installation and service performed by qualified Cleveland Range authorized personnel.

B. Operational Safety

The Operational Safety section outlines minimum safety policies and procedures for operating one or more Cleveland Range appliances.

1. Do not store anything on top of the appliance.
2. KEEP THE APPLIANCE AREA FREE AND CLEAR OF COMBUSTIBLES.
3. Proper air supply for ventilation is REQUIRED for and CRITICAL to safe, efficient operation of this appliance.
4. Place non-slip draining anti-fatigue mats rated for use in wet, greasy, or dry work areas on the floor in front of the appliance and other locations as needed. Obtain the best mats for your needs from your local supplier.
5. Wear BOOTS appropriate to the work area to help protect feet, and to help prevent slips and falls.
6. Allow only qualified Cleveland Range authorized service representatives to service the appliance.
7. Use only factory authorized repair parts.
8. Maintain written records of appliance service, maintenance, and repair. See Chapter 7.

DANGER

Operating this appliance out of level can cause DEATH, INJURY, and EQUIPMENT DAMAGE. This appliance must be level both front-to-back and side-to-side in all installations. **NEVER** operate this appliance out of level. If this appliance is suspected to be out of level, shut it down at once and call your qualified Cleveland Range authorized service agency immediately.

DANGER

Without power, there is **NO** safe method of operation of this appliance.
DO NOT ATTEMPT TO START OR OPERATE this appliance during a power failure.
DEATH, INJURY, AND/OR EQUIPMENT DAMAGE may result.

NOTICE

The use of good quality feed water as listed in the Cleveland Range Limited Warranty is the responsibility of the Owner-User.
See Water Quality Recommendations as listed in the Cleveland Range Limited Warranty.
THE USE OF POOR QUALITY FEED WATER WILL VOID EQUIPMENT WARRANTIES.

DANGER

BURN and SCALD HAZARD

Exposure to steam, condensate, and hot surfaces can cause death, burns, and scalds.

To help avoid injury:

- Do **NOT** breathe steam or condensate.
- Stand on the hinge side and away from the appliance and slowly open the cooking compartment door.
- **Open the door slightly to allow steam, condensate, and heat to vent before looking or reaching into the cooking compartment.**
- Always wear **DRY** heatproof gloves when reaching into the cooking compartment or handling hot items. Wet or damp gloves conduct heat and may cause burns when handling hot items.
Failure to follow these precautions can result in death, burns, and scalds.

WARNING

This appliance is not GFI (GFCI) compatible.
Do not use a GFI (GFCI) circuit.
Using a GFI (GFCI) circuit can result in injury, equipment damage, and property damage.

WARNING

Never operate a SteamChef™ Steamer without the KleanShield™ properly installed in the bottom of the water reservoir or the fan guard installed over the fan.
Failure to do so can cause injury and equipment damage

CHAPTER 2 PRODUCT INFORMATION

A. Product Information

- This manual covers the operation of 22CET3.1 and 22CET6.1 SteamChef Steam Cookers (steamers), and their standard features and options.
- Other than selection of options, there are presently no significant design, parts, or operating differences among appliances with this model number.
- Figures 2-1 and 2-2 illustrate the dimensions, clearances, and major external features of 22CET's.

B. Model Numbers and Serial Numbers

1. Cleveland Range, LLC assigns two product identification numbers to each appliance: a model number and a serial number.
2. Please provide this information when you contact Cleveland Range or a qualified Cleveland Range authorized service representative:

- Model Number _____
(Write the Model Number of your appliance here.)
- Serial Number _____
(Write the Serial Number of your appliance here.)

C. Product Information Plate

The Product Information Plate on the back of the appliance lists:

- Model
- Serial Number
- Power and Wiring Requirements

D. Product Views

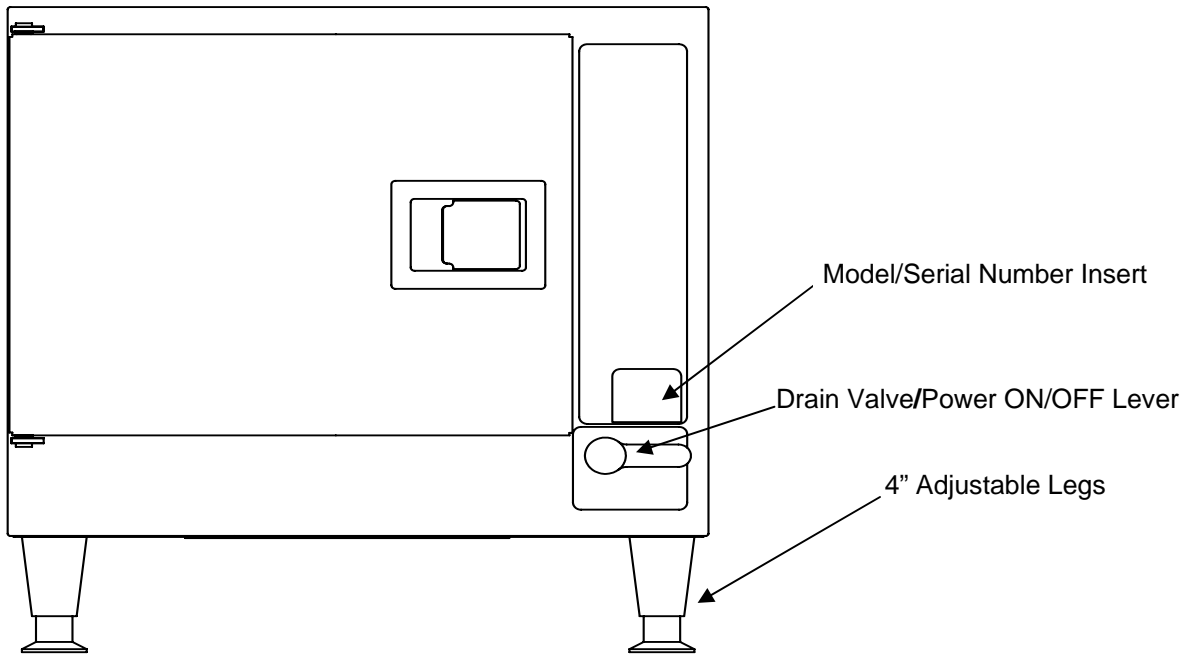

**Figure 2-1 SteamChef™ Steam Cooker Front View
(Model 22CET3.1 Shown)**

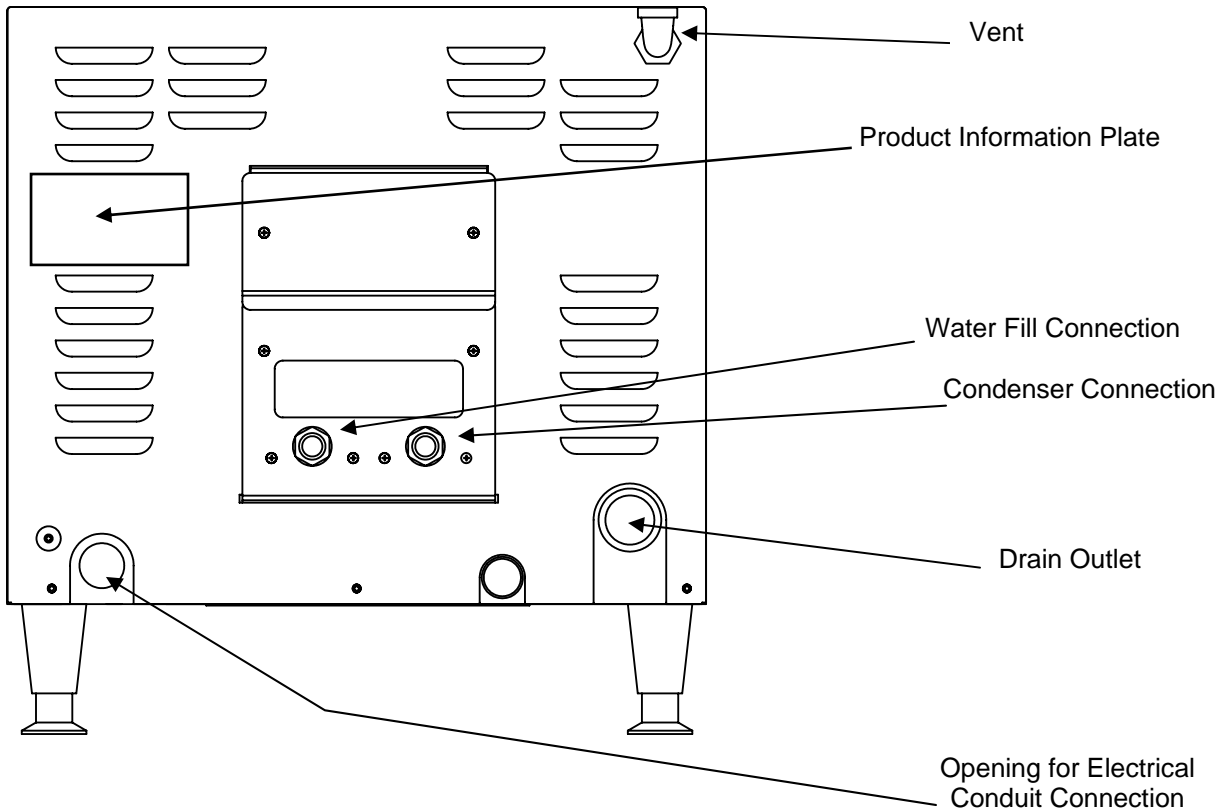

**Figure 2-2 SteamChef™ Steam Cooker Rear View
(Model 22CET3.1 Shown)**

CHAPTER 3 OPERATION

A. Main External Power Switch

- Usually the Main External Power Switch is left ON.
- To turn ON the Main External Power Switch:
 1. Turn the ON/OFF lever/switch to the OFF position.
 2. Turn ON the Main External Power Switch. See Figure 3-1.

NOTE: The appliance will perform the automatic 3-minute drain rinse cycle.

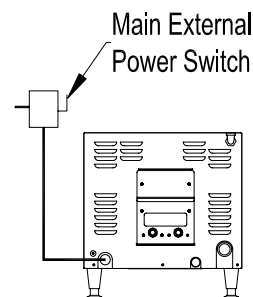

Figure 3-1

B. Door Interlock Switch

The steamer compartment of the SteamChef Steamer is equipped with an automatic door interlock switch that turns off the heating elements and shuts off the convection fan and condenser when the door to the compartment is opened.

⚠ WARNING

Burn and Scald Hazard

Even though the heat shuts off as soon as the door is opened, it may take up to a minute for production of steam to end and residual steam in the system to clear from the cooking compartment.

To help avoid injury, always wait until the residual steam clears and the convection fan stops before reaching into the cooking compartment, and always wear dry heatproof gloves when reaching into the cooking compartment. Wet or damp gloves conduct heat and can cause burns when touching hot items. Failure to do so can cause burns, scalds, and other injuries.

C. Inspect the Cooking Compartment

1. Inspect the cooking compartment while the steamer is cold. After the steamer is turned on, it will be too hot to inspect or clean safely.
2. Before turning ON the power switch/lever to the SteamChef steamer make sure the inside of the steamer is clean. See Chapter 6 for complete cleaning instructions.
3. Remove the door gasket assembly, pan racks, backplate, fan guard, and KleanShield™ and make sure all surfaces are clean and drain openings and the water level sensors are clean and free of any residue or debris (See Figure 3-2).
4. Make sure that the KleanShield™ drain is clear by pouring about a quart of water through the KleanShield™ drain (See Figure 3-4 and 3-5). Make sure that the water flows out the steamer drain.

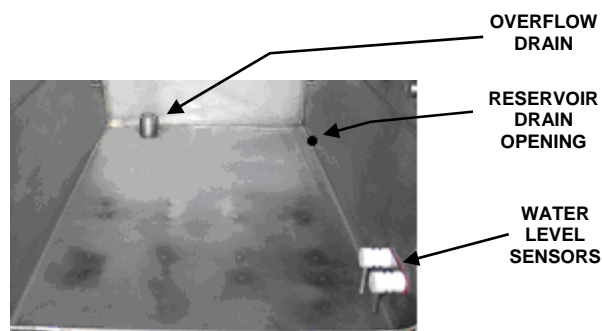

Figure 3-2 Inspecting
Compartment drains
(Model 22CET3.1 Shown)

D. Install/Remove the Slide Racks (Pan Racks)

- See Figure 3-3. Each rack has four loops; two top, and two bottom.
- 1. Hold the slide rack so the ends of the hanger loops are towards compartment wall.
- 2. Slide one rack into the cooking compartment with the loop side closest to the compartment wall and rack slots horizontal.
- 3. Hook the loops over the top and bottom pins
- 4. Repeat steps 1, 2, and 3 for the other rack.

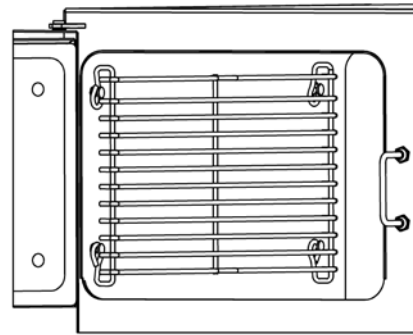

Figure 3-3
Slide Rack Installation

E. Install/Remove the KleanShield™

⚠ WARNING

Never operate a SteamChef without the KleanShield™ properly installed. The properly installed KleanShield™ helps protect the operator from scalding water splashing out of the reservoir, and helps prevent drain blockage. Operating a SteamChef without the KleanShield™ properly installed can cause injury, equipment damage, and reduce performance.

- Note: The KleanShield™ is dishwasher safe.
- To **Install** the KleanShield™:
 1. Remove the pan racks.
 2. Place the KleanShield™ into the SteamChef so the drain trough pipe slips into the KleanShield™ drainpipe at the rear of the cooking compartment.
 3. Carefully lower the front of the KleanShield™ so the Water Level Sensor Guard is behind the probes and the front legs rest on the bottom of the cooking compartment.
- To **Remove** the KleanShield™, turn off the SteamChef and wait for it to cool, remove the pan racks, carefully lift the front of the KleanShield™, lift the drain trough pipe from the drain pipe, and remove the KleanShield™ from the cooking compartment.

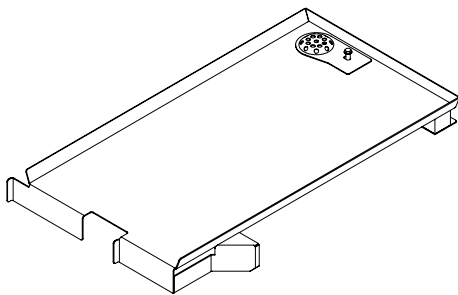

Figure 3-4
KleanShield™

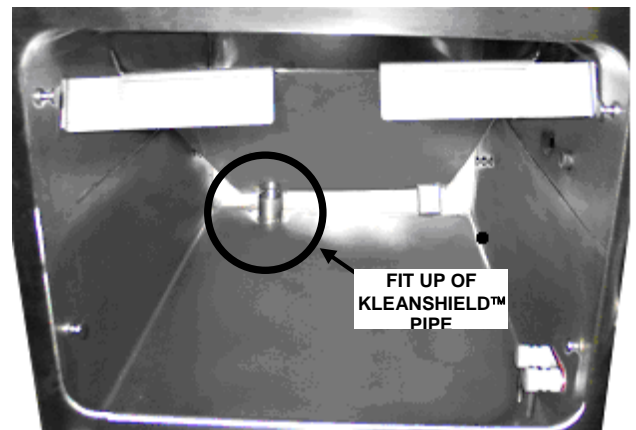

Figure 3-5
KleanShield™ Installation
(SteamChef 3.1 shown)

F. Install the Fan Guard and Air Diverter

⚠ WARNING

The fan guard helps protect the operator from injury caused by the rotating fan blades. Never operate a SteamChef without the fan guard properly installed. Operating a SteamChef without the fan guard properly installed can cause injury, equipment damage, and reduced performance.

- See Figure 3-6
1. Hold the fan guard so that the large ends of the keyholes are towards the bottom of the steamer.
 2. Place all four openings over the mounts located on the rear wall of the steamer
 3. Pull it down so that the narrow ends of the slots are pulled tight over the mounts. See Figure 3-6.
 4. Place the air diverter onto the fan guard as shown.

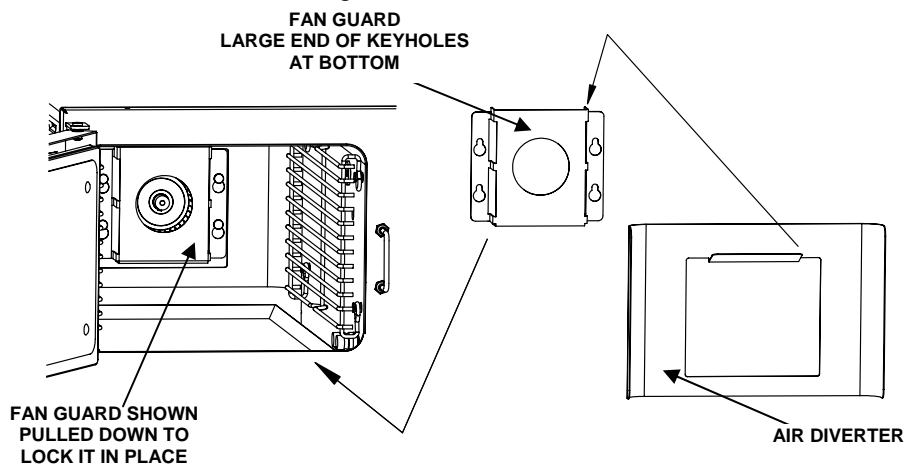

Figure 3-6
Fan Guard and Air Diverter Shown in Installed Position

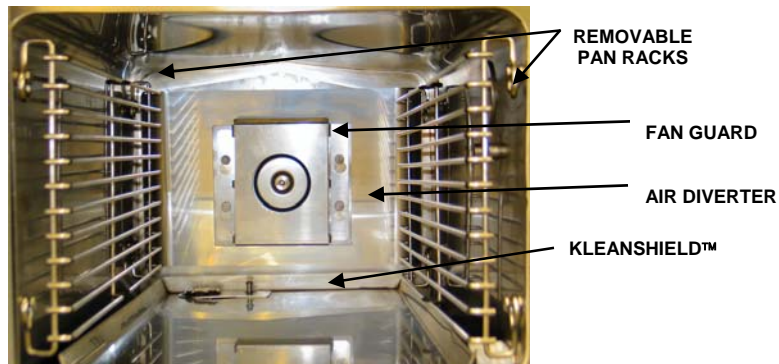

Figure 3-7 Inspecting Compartment
Interior Accessories
(Model 22CET3.1 shown)

G. Power ON (Auto Water Fill/Automatic Preheat)

1. Open the water supply valves to the steamer.
2. Set the Timed/Manual switch to timed (dial timer steamers) or set the Selector Switch to OFF (ON/OFF control steamers).
3. Turn ON power to the steamer by turning the drain valve lever clockwise (down) to close the drain (see Figure 3-8). The power ON indicator lights and the water reservoir fills.
4. Close the door. When the water reservoir is filled to the minimum operating level the heater turns on and heats the water to the standby cooking temperature.
5. Time to Standby Temperature:
 - Dial timer steamers: When the “SureCook” indicator light goes OFF, the steamer is preheated.
 - ON/OFF control steamers take 10 to 15 minutes to reach the standby heating temperature.

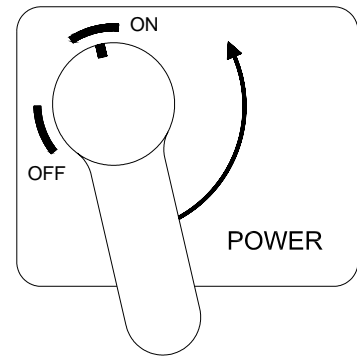

Figure 3-8
ON/OFF Lever
(Shown in ON Position)

H. Preheat the Steamer

- Preheat to help ensure productivity and consistency.
- **BEFORE PREHEATING:** Inspect and clean the compartment. After preheating, the compartment will be too hot to inspect and clean safely.
- To preheat the SteamChef Steamer:
 1. Close the steamer door and turn the steamer ON 15 minutes before cooking.
 2. The Steamer will heat to the standby temperature.

I. High Limit Reset

- This steamer has a high limit lockout to protect the unit from overheating.
- If the high limit lockout temperature is reached:
 1. The RESET light will turn ON
 2. A buzzer will sound continuously
 3. The heater will shut OFF
 4. The steamer must be reset before cooking can continue
- To reset the high limit:
 1. Turn OFF power to the steamer with the ON/OFF lever.
 2. Wait 15 minutes for the steamer to cool
 3. Make sure the water probes are clean (Chapters 3 and 6).
 4. Refill with water and restart according to the Power ON instructions (Chapter 3).
 5. If the problem repeats, see the Operators Troubleshooting Guide (Chapter 8).

CHAPTER 4 CONTROL PANELS

▲ CAUTION

Press switches and keys with fingertips only.
Injury and equipment damage can result from pressing switches and keys with anything else.

A. Keypad Timer Control Panel

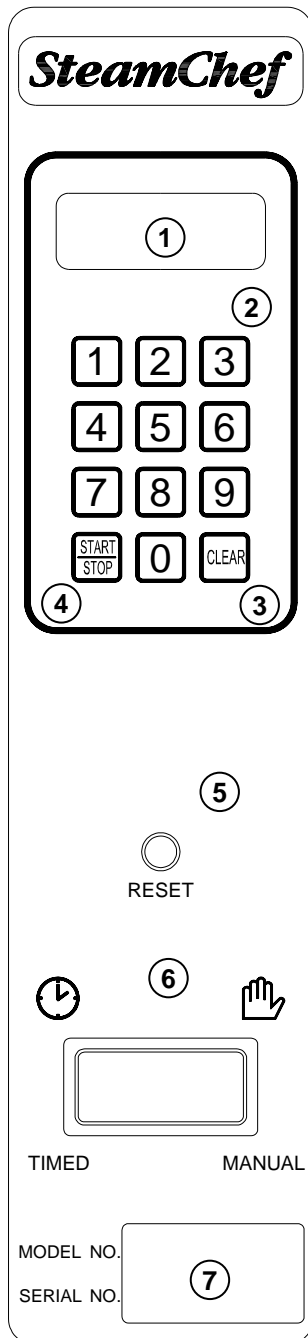

1. **TIMER Display**
 - The four-digit display shows the minutes and seconds remaining in the countdown.
 - The display reads from zero (00:00) to 99 minutes and 99 seconds (99:99).
 - Pause (PAUS) appears when the count down is stopped by the START/STOP key or by SureCook.
2. **Number Keys 0-9**
 - These keys set the number of minutes and seconds in the timer count down.
 - Example: Pressing the number keys 1, 2, 3, 4, sets the timer for 12 minutes and 34 seconds (12:34).
3. **CLEAR Key**
 - This key resets the Timer to zero (00:00) after it has been stopped.
 - The Timer must be reset to zero (00:00) ("zeroed") by pressing this key before a new time can be set.
4. **START/STOP Key**
 - Press this key to start and stop the Timer.
 - In TIMED mode, press this key to start and stop both the Timer and steaming.
 - In MANUAL mode, the Timer counts down but does NOT start or stop steaming.
 - Press this key to silence the buzzer.
5. **RESET Indicator** lights when the High Limit circuit trips. The light stays ON, and a buzzer sounds until the appliance is reset.
To reset:
 - 1) Turn OFF power to the steamer with the Power ON/OFF Lever.
 - 2) Wait 15 minutes for the appliance to cool.
 - 3) Make sure the probes are clean.
 - 4) Follow the Power ON instructions.
 - 5) If the appliance needs reset again, see the Operator's Troubleshooting Guide.
6. **TIMED/MANUAL Switch**
 - The TIMED/MANUAL switch selects the Timed or Manual Mode.

To Use the KEYPAD Timer in Manual Mode:

 - The Timer does NOT start or stop steaming in Manual Mode.
 - 1) Set and start the Timer.
 - 2) The KEYPAD Timer counts down only when the cooking compartment is at cooking temperature.
 - 3) The buzzer sounds when the Timer reaches zero.
7. **Serial Number/Model Number Insert.**

**Figure 4-1
Keypad Timer
Control Panel**

B. Dial Timer Control Panel

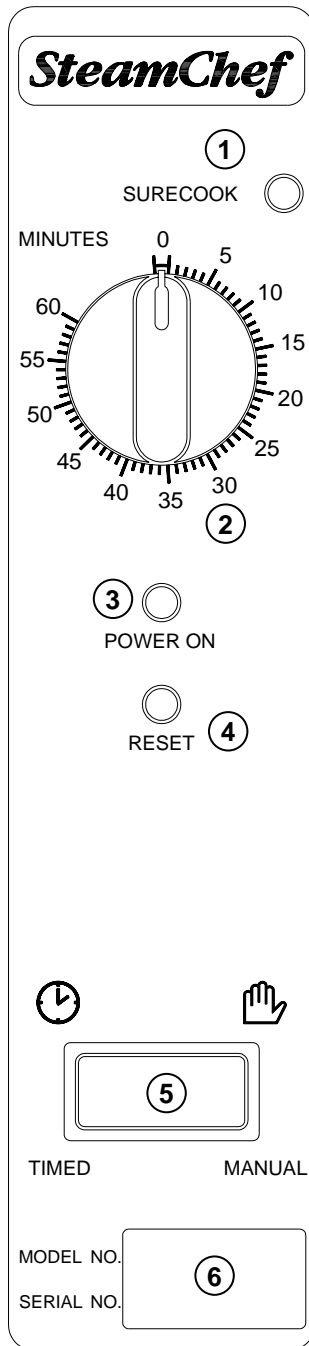

Figure 4-2
Dial Timer
Control Panel

1. SURECOOK Indicator Light
 - This light is lit whenever the cooking compartment is below cooking temperature.
 - Note: When in the Timed mode, the timer will not count down when this light is ON.
2. TIMER
 - The Dial Timer sets the operating time from 0 to 60 minutes.
 - Turn the knob clockwise until it points to the required time.
 - When the Timer reaches 0, a buzzer sounds for 3 seconds.
 - The Dial Timer does **NOT** work in Manual Mode.
3. POWER ON Indicator Light
 - When the Green indicator light is ON, power is ON to the controls.
4. RESET Indicator lights when the High Limit circuit is open. The light stays ON, and a buzzer sounds until the appliance is reset.

To reset:

 - Turn OFF power to the steamer with the Main Power ON/OFF LEVER.
 - Wait 15 minutes for the appliance to cool.
 - Make sure the probes are clean.
 - Follow the Power ON instructions.
 - If the appliance needs reset again, see the Operator's Troubleshooting Guide.
5. TIMED/MANUAL Switch selects the manual or timed operating mode.
6. Serial Number/Model Number Insert.

C. ON/OFF Control Panel

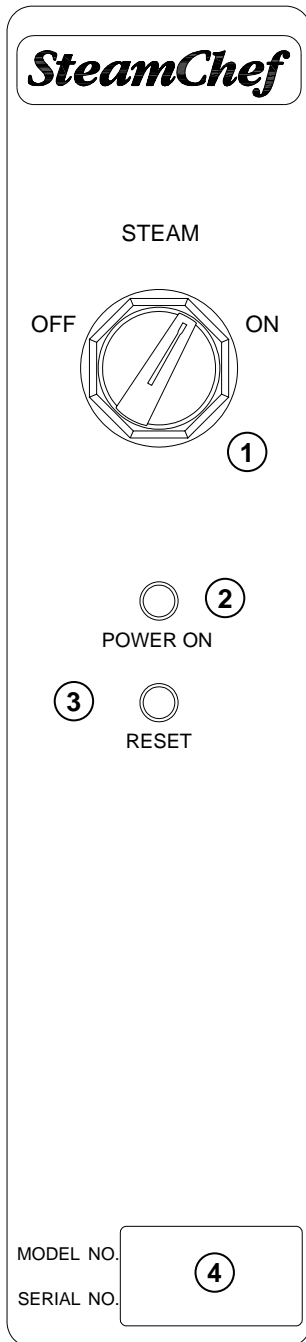

Figure 4-3
On/Off Control

1. ON/OFF Selector Switch
 - a. ON starts Constant Steam Mode for 1 hour unless the door is opened.
 - b. OFF stops Constant Steam Mode and lowers the cooking compartment temperature to Standby.
2. POWER ON Indicator Light
 - When the Green indicator light is ON, power is ON to the controls.
3. RESET Indicator lights when the High Limit circuit is open. The light stays ON, and a buzzer sounds until the appliance is reset.

To reset:

 - Turn OFF power to the steamer with the Main Power ON/OFF LEVER.
 - Wait 15 minutes for the appliance to cool.
 - Make sure the probes are clean.
 - Follow the Power ON instructions.
 - If the appliance needs reset again, see the Operator's Troubleshooting Guide.
4. Serial Number/Model Number Insert

CHAPTER 5 COOKING WITH THE SteamChef

DANGER

**DO NOT BREATHE STEAM, HOT AIR OR CONDENSATE
DEATH OR INJURY WILL RESULT.**

WARNING

Hot Air, Steam, and Condensate will cause Burns and Scalds.

To help prevent burns and scalds when opening steamer doors: always stand to the hinge side and back from the doors, slowly open the door, and wait for the steam and heat to dissipate before carefully opening the door.

CAUTION

Some foods drip juices.

Use a solid catch pan under perforated pans when cooking food that drips juices.
Dripping juices can cause burns, and clog the drain and KleanShield™.

CAUTION

Do **NOT** use oven racks that are bent or otherwise damaged in any way.

DO Insert pans and accessories **LEVEL** and **INSIDE** the oven racks.

Pans and accessories placed in damaged or out of level racks, or outside racks can tip and spill, causing burns, injuries and/or equipment damage

WARNING

The SteamChef Steamer is a continuously operating appliance so parts are **ALWAYS HOT** when the main external power switch or the ON/OFF lever is in the ON position.

When the ON/OFF lever is turned to the OFF position, the SteamChef will remain HOT for some time.

Contact with hot surfaces and steam can cause burns and scalds.

Avoid contact with hot surfaces and steam.

WARNING

If the steamer door is stuck shut: DO NOT force the door open.

The door stuck shut may indicate a blocked drain.

Hot water can fill the cooking compartment and spill out if the door is forced open causing injury and equipment damage.

If the SteamChef door is stuck shut:

- Turn OFF the steamer.
- Call a qualified Cleveland Range authorized service technician.
- Wait for the steamer to cool before servicing.

A. Operating and Cooking Procedure – All Models

NOTE: The 22CET has an Energy/Water Saver Feature that automatically lowers the cooking compartment temperature to the Standby temperature if the steamer is left in Manual Mode (timer models) or is left ON (ON/OFF models) for more than 60 minutes without opening the door. Also, the condenser water does not flow until the cooking compartment reaches the minimum cooking temperature to reduce steam loss and condenser water use.

- If cooking times longer than 60 minutes are required, open and close the cooking compartment door after 60 minutes to reset the timer.
 - If condenser flow starts before the cooking compartment reaches cooking temperature, turn OFF the steamer and call your qualified Cleveland Range authorized service representative.
1. Before Cooking or Rethermalizing
 - a. Inspect the cooking compartment, drain, KleanShield™, and clean as required BEFORE turning ON the SteamChef. It will be too hot to inspect and clean safely after turning ON. See Chapters 3 and 6.
 - b. Turn ON and fill the SteamChef. See Chapter 3.
 - c. Preheat the cooking compartment. See Chapter 3.
 - d. Slide the pans of food into the slide racks inside the SteamChef. Do not place pans or anything else on the bottom of the compartment or on the KleanShield™.
 - e. For best results, use 2-1/2 inch deep, perforated pans without covers. These give the best heat transfer and shortest cooking time.
 - f. Close the cooking compartment door.
 2. While cooking, occasionally check the water in the reservoir for food particles and oils. If the water is dirty or cloudy, change the water. See Chapters 3 and 6.
 3. After Cooking or Rethermalizing
 - a. Carefully open the cooking compartment door and remove the pans from the slide racks.
 - b. If the SteamChef will not be used again, perform the Cleaning Procedure in Chapter 6.

B. Operating and Cooking Procedure – Timed Mode

In Timed Mode, the Timer starts and stops the cooking operation.

NOTE: When in the Timed Mode and the compartment door is closed, and the Timer is NOT set, the cooking compartment remains at the Standby temperature.

1. The control panel settings must be:
 - The ON/OFF Lever is in the ON (down) position and the Power indicator light is lit.
 - The TIMED/MANUAL switch is in the TIMED position.
2. Set the required cooking time. The Timer starts counting down as soon as the compartment reaches cooking temperature.
3. When the Timer reaches zero, a buzzer sounds for 3 seconds; the heater turns OFF, and the cooking compartment temperature lowers to the Standby temperature.

C. Operating and Cooking Procedure – Manual Mode

The operator starts and stops the steaming operations, and controls the cooking time, including cooking compartment heat-up time.

NOTE: If cooking times longer than the 60 minutes are desired, it is necessary to reset the Energy/Water Saver timer.

To reset the timer without interrupting the cooking, quickly open and close the cooking compartment door.

Tip: Use the Manual Mode to maintain the cooking compartment temperature between batches.

1. The control panel settings must be:
 - The ON/OFF Lever is in the ON (down) position and the Power indicator light is lit.
 - The TIMED/MANUAL selector switch is in the MANUAL position. The steaming cycle starts as soon as the switch is moved to MANUAL.
2. To stop steaming in Manual Mode: set the selector switch to the TIMED position and make sure that the Timer is set to zero. The burner turns off, and steam production in the cooking compartment gradually stops.

D. Operating and Cooking Procedure – ON/OFF Control Panel

- The operator starts and stops steaming operations.
- There is NO SureCook light. The operator preheats or reheats the SteamChef as desired.
- When turned ON, cooking with the SteamChef is the same as cooking with a Dial Timer Control SteamChef in the Manual Mode with a fixed 60-minute timer.
- For longer cooking times, switch OFF and back ON to reset the fixed 60-minute timer.
- When turned OFF, the cooking compartment lowers to Standby temperature.

E. Operating Procedure – Rethermalization

- The SteamChef may also be used to reheat/rethermalize previously cooked and/or refrigerated foods to serving temperature.
- Depending on initial food temperature and density, most foods will rethermalize to their safe serving temperature in 10 to 40 minutes.

To use the SteamChef to reheat/rethermalize food to a safe serving temperature.

1. Always check internal temperature of food with a thermometer to determine that it has been rethermalized to its safe serving temperature.
2. If rethermalizing times longer than the 60 minutes are required, resetting the Timer is necessary.
 - To reset the Timer without interrupting the continuous operation of the SteamChef, quickly open and close the cooking compartment door.

CHAPTER 6 SHUTDOWN AND CLEANING

A. SHUTDOWN AND CLEANING PROCEDURE

This procedure should be performed at the end of each day or shift, or more frequently if the water supply does not meet the Minimum Water Quality Requirements in the Warranty.

WARNING

The steamer stays hot for a long time.
To help avoid burns: Allow the steamer to cool completely before cleaning or servicing.

WARNING

Do NOT use hoses, power cleaners, or pressure washers on or in the SteamChef Steamer.
Doing so can cause electric shock and / or damage electrical and electronic components.

WARNING

A clogged or slow drain can cause hot water to collect in the oven compartment and spill out when the door is opened causing injury and equipment damage.

Never push food debris or scale down the steamer drain, or through the KleanShield™ opening. Debris and scale can build up in the drain system and clog or slow the drain and lead to additional maintenance and service problems.

Always remove any solid matter from the inside of the steamer with a rag or spatula before rinsing cleaning water down the drain.

WARNING

When cleaning: do NOT pick up or tilt the SteamChef. If it is necessary to move a SteamChef for cleaning, turn OFF power at the Main External Power Supply and at the ON/OFF Lever to drain the water from the SteamChef.

Injury and equipment damage can result from shifting the SteamChef out of level while the power is turned on at the Main External Power Supply and/or water is in the SteamChef .

The steamer MUST BE LEVEL BOTH FRONT TO BACK AND SIDE TO SIDE in all mounting arrangements before operation. Check level front to back and side to side before restoring power as described in the Installation Manual after moving the SteamChef.

Failure to do so can cause injury and equipment damage.

Cleaning Procedure (Continued)

1. Turn the ON/OFF lever counter-clockwise (up) so that the white reference marker on the lever is pointing directly left to turn the power OFF, de-energize all controls, and drain the steamer. The appliance will begin a 3-minute drain rinse cycle to clean the drain system
2. Open the cooking compartment door and allow steamer to cool.
3. Remove any spilled food from the surface of the KleanShield™.
 - Never push food scraps down the KleanShield™ opening or the reservoir drain opening.
4. Remove the slide racks, fan guard and KleanShield™. Wash and rinse slide racks, fan guard and KleanShield™ separately or clean them in a dishwasher according to health requirements.
5. Remove any spilled food from inside compartment and clear any residue from the drain valve and the KleanShield™ drain opening.
 - Do not push food debris or scale down the steamer drain, or through the KleanShield™ drain.
6. Clean the interior of the compartment thoroughly, removing all food particles and scale from the steamer.
7. Wipe down the interior of the cooking compartment with a half water and half white household vinegar solution. Use a spray bottle of the same vinegar solution to rinse the convection fan located at the back of the cooking compartment.
 - When done daily this will help prevent the buildup of calcium and other mineral deposits left over from the boiling of water, and prevent scale buildup in the steamer, helping prevent more costly maintenance and service on the steamer.
 - Cleveland Range does not recommend the use of detergent, but if detergent has been used to clean the inside of the steamer, be sure to rinse off the probe assembly with the vinegar solution. If detergent residue is not completely rinsed from the probe assembly then the residue can prevent the water level control from operating.
8. Use a soft bristle brush to clean the water sensor, temperature probe, and fan and to remove stubborn food particles.
9. Do not use abrasive cleaning compounds or steel wool.
10. Rinse the inside of steamer compartment and drain valve thoroughly with clean water.
11. Inspect the probe assembly and clean it with a soft bristle brush or similar non-abrasive cleaning means.
12. Clean the door assembly.
 - a. Remove the door gasket assembly (see Figure 6-1).
 - b. Note the keyhole slots on the door and the retaining pins on the gasket assembly. Grasp the gasket assembly at the sides and lift up and towards you to remove the assembly.
 - c. Clean all surfaces of the gasket assembly, as well as the inside of the door, by wiping with a damp cloth.
 - d. Rotate the liner assembly 180° and replace the gasket assembly by sliding the retaining pins into the keyhole slots. Either long edge of the gasket assembly can be positioned at the top. Periodic rotating of the door assembly will help increase the door gasket life.
13. Replace the cleaned KleanShield™, slide racks and fan guard. (See Chapter 3.)
14. Wipe the exterior with a damp cloth only.
15. NEVER HOSE DOWN THE STEAMER. Electrical components inside the unit will not function correctly if wet or damp and may cause a shock hazard.
16. After cleaning, leave the steamer door open until the next steamer operation. This prevents compartment odor buildup and helps increase gasket life.

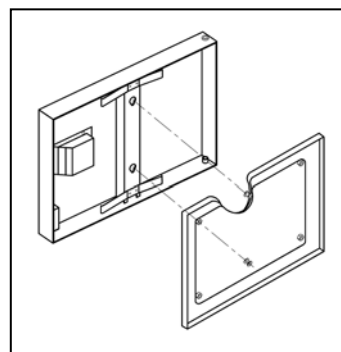

Figure 6-1
Door Gasket Assembly

CHAPTER 7 PREVENTATIVE MAINTENANCE

A. MAINTENANCE

Maintenance on the steamer must be performed on a regular basis to keep it running properly and efficiently. By following the maintenance instructions in this chapter and cleaning the equipment regularly as outlined in Chapter 6, problems with the steamer will be kept to a minimum. The frequency of steamer maintenance may need to be increased, depending on equipment usage and water quality. If problems occur, refer to the Operator's Troubleshooting Guide in Chapter 8. For more information on product and services, contact your sales representative.

1. Maintenance Records

Make a file for maintenance and repair records only. Keep a written record of daily, weekly, monthly, and yearly maintenance. These records will help protect warranty coverage, help schedule maintenance procedures, help keep the SteamChef cooking properly, and assist service personnel.

2. Daily Maintenance

a. Checking and Changing the Water

When using the SteamChef Steamer frequently check the water, especially if cooking with perforated pans. Although most food drippings will be caught by the KleanShield™, the water may become dirty from spills falling over the edge of pans when loading, cooking, and emptying the steamer. Change the water (see below) when the water becomes cloudy or contaminated with food particles.

- **CHANGE THE WATER IN THE STEAMCHEF STEAMER AT LEAST EVERY DAY IN ORDER TO MAINTAIN FOOD QUALITY AND KEEP THE STEAMER SANITARY.**

Note: It may be necessary to change the water several times a shift, especially if cooking strong-flavored foods or using perforated pans.

b. To Change the Water in the Reservoir:

- 1) Turn the ON/OFF lever counter-clockwise (up) so that the white reference marker on the lever is pointing directly left to turn the power OFF, de-energize all controls, and drain the steamer.
- 2) Open the steamer door and allow steamer to cool.
- 3) Remove the KleanShield™. Remove any food particles and rinse the KleanShield™ with clean water.
- 4) Remove any spilled food from inside compartment and rinse any residue from the drain valve and the KleanShield™ drain.
- 5) Replace the KleanShield™. See Chapter 3.
- 6) Turn ON power to the steamer by turning the drain valve lever clockwise (down) to close the drain (see Figure 3-8). The power ON indicator will light. The steamer will automatically begin filling with water to the normal operating level.
- 7) Close the door. The "SureCook" indicator will light (timer models only), and the steamer will begin to automatically heat the water supply to the standby cooking temperature.
- 8) When the "SureCook" indicator light turns OFF (timer models only) the Steamer is ready to begin cooking.

c. Clean the Steamer

Clean interior and exterior of the steamer according to the Shutdown and Cleaning Instructions in Chapter 6 at least once a day or at the end of each shift.

3. Yearly Maintenance – Clean the Water Strainers (Filter Washers)

Clean the water line strainers at least once a year.

NOTE: When the steamer is first installed, check the strainer more frequently to find out how often the strainer must be cleaned.

- a. Turn OFF power to the steamer at the Main External Power Switch.
- b. Close the valves in the steamer water supply lines.
- c. Unscrew the hoses from the inlet fittings located on the rear of the steamer.
- d. Remove the filter washers (See Figure 2-2 and 7-1) from the outlet of the hoses and wash them with clean water.
- e. Check the filter washer for wear and replace it if necessary.
- f. Put the filter washers into each of the water inlets and reconnect the hoses to the back of the steamer.
- g. If treated water is used to supply water to the reservoir, make sure that it is connected to the left inlet at the rear of the steamer. (See Figure 2-2.)
- h. Open water supply valve(s) and check for water leaks.
- i. Turn power back on to the steamer at the Main External Power Switch.

NOTE: The appliance will perform the automatic 3-minute drain rinse cycle

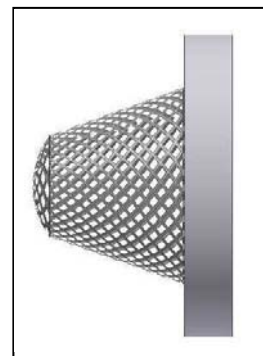

Figure 7-1 Filter Washer Assembly (P/N 110987)

B. Descale the Water Reservoir

NOTICE: Only qualified Cleveland Range authorized technicians or trained onsite maintenance personnel may perform this procedure.

1. Is Descaling Necessary?
 - a. Although, a SteamChef should not normally require this procedure, the use of “hard” water or failure to follow the cleaning procedures in Chapter 6 may cause the accumulation of scale in the SteamChef.
 - b. Scale can deposit in the bottom of the SteamChef reservoir and/or in its drain. Descaling can help prevent a costly service call if scale buildup begins to impair the SteamChef’s operation.
 - c. Descaling is not normally required on a SteamChef. Frequency will depend on water quality, and the frequency of shutdown and cleaning of the water reservoir as described in Chapter 6.
 - d. The frequency of descaling must be determined by the owner and performed by qualified Cleveland Range authorized technicians, or trained onsite maintenance personnel.
2. If descaling is necessary, Cleveland Range recommends the use of DISSOLVE® Descaler Solution, Cleveland Range Part No. 106174. No other system of descaling should be used. NOTE: Part No. 106174 is the Part No. for a case (6 1-gallon containers) of DISSOLVE® descaler.
3. Follow the instructions included with the DISSOLVE® Descaler Solution. Call Cleveland Range at 216-481-4900 or 1-800-338-2204 if there are any questions.

4. Descale Procedure

DANGER!

The liquid solution in Cleveland Range Descaler Solution Part No. 106174 can be harmful if not handled properly. Follow these basic safety rules for handling and using this product. Instructions and warnings on container labels supercede all other warnings and instructions.

Wear protective clothing when mixing or applying chemical cleaners

Wear rubber gloves, and OSHA approved eye protection when descaling

Avoid breathing fumes

If liquid contacts skin: wash with soap and water

If chemical contacts eyes: flush with water and seek medical attention

If chemical is swallowed or ingested: drink 1 or 2 glasses of water and seek medical attention

FAILURE TO DO SO CAN CAUSE DEATH OR INJURY

WARNING

Descaling procedure is slightly different depending on model. This entire procedure must be read and fully understood as it applies to the model being descaled, before beginning descaling operations.

Failure to do so can cause injury and equipment damage.

CAUTION

Do not use any other product or method of descaling other than the *DISSOLVE*[®] Descaler method using Part No. 106174.

Failure to do so can cause injury and equipment damage.

- Cleveland Range recommends DISSOLVE[®] Descaler Solution, Part No. 106174.
- Use no other system of steamer descaling
- Appropriate warnings and safe handling procedures must be provided to handlers and users
- Instructions and warnings on Dissolve[®] containers and Material Safety Data Sheets supercede and replace instructions and warnings in this manual
- General precautions: wear rubber gloves, splash goggles and other protective clothing and equipment as necessary. Refer to Dissolve[®] container labels and Material Safety Data Sheets for information regarding eyewash, first aid, medical treatment, and spill control.

MODEL 22CET3.1 and 22CET6.1, BOILERLESS STEAMER DESCALING PROCEDURE (For DISSOLVE® Descaler Solution Part No. 106174)

- The entire procedure must be read and fully understood before beginning descaling.
- This procedure takes about 1 hour 30 minutes to complete.
- Repeat this procedure as needed for heavy scale buildup.
- Regular cleaning of the steamer with vinegar per the instructions found in the Shutdown and Cleaning Instructions may help reduce need for descaling. See Chapter 6.
- Sides, back, and top of steam compartments may be descaled with a vinegar solution and a soft brush. See Chapter 6.

- 1) Open the door to the cooking compartment.
- 2) Set the TIMED/MANUAL switch to TIMED **OR** the ON/OFF switch to OFF.
- 3) Set the ON/OFF lever to the OFF position.
 - The 3 minute drain cycle starts.
- 4) Remove the Pan Racks and KleanShield™ from inside the steamer.
 - Heavily scaled pan racks and KleanShield™ may be descaled by soaking them in a solution of 1 part Dissolve® and 4 parts water, rinsing thoroughly with cold water, and washing them in a dishwasher.
- 5) Remove any loose scale from the bottom of the steamer.
- 6) When the drain cycle is done, turn the ON/OFF lever to ON to refill the unit.
- 7) Do not start the timer.
- 8) Leave the door open.

NOTE: DO NOT HEAT THE STEAMER DURING DESCALING.

- 9) While the reservoir is filling with water, pour 1 to 1 ½ quarts (about a third of a 1-gallon bottle) of DISSOLVE® descaler solution into the water reservoir.
 - While adding DISSOLVE® descaler to the reservoir, pour it in slowly to avoid splashing the liquid or overflowing the reservoir.
- 10) After automatic fill ends, turn OFF the Main External Power Switch. See Figure 3-1.
- 11) Leave the door open and let the DISSOLVE® work for 1 hour.
- 12) At the end of 1 hour, set the ON/OFF lever to the OFF position.
- 13) Turn the power ON at the Main External Power Switch.
- 14) After the 3-minute drain cycle completes, turn the ON/OFF lever back ON. (NOTE: If the reservoir does not fill, dry off the water probe assembly).
- 15) After filling stops, add 1/2 gallon of water to the reservoir. Do not overflow the reservoir.
- 16) Turn the ON/OFF lever OFF to start the drain cycle.
- 17) After the reservoir drains, set the ON/OFF lever to the ON position to refill the reservoir.
- 18) Close the cooking compartment door and set the timer for 20 minutes (ON/OFF Control Models: set the control to ON.). The steamer heats to normal operating temperature.
- 19) After 20 minutes turn OFF ON/OFF controls and turn the ON/OFF lever to OFF.
- 20) The 3-minute drain cycle starts.
 - This is the final rinse of the reservoir.
- 21) If the reservoir drains slowly even after being descaled, turn OFF the steamer and clean the drains with a NSF approved drain cleaner.
- 22) Once the scale is removed and the drain flows freely, the steamer is ready for normal operation.

CHAPTER 8 OPERATOR'S TROUBLESHOOTING GUIDE

The Troubleshooting Guide is a list of symptoms of problems that may occur during routine operation.

- "Problem" (left column) lists common operating problems.
- "Possible Cause" (center column) lists causes of problems in the order they should be checked.
- "Remedy / Reference" (right column) lists fixes for problems from easiest to hardest.
- "Notes" in "Remedy / Reference" column are at end of the Troubleshooting Guide.

ATTEMPTING TO REPAIR OR CORRECT PROBLEMS REQUIRING A QUALIFIED CLEVELAND RANGE AUTHORIZED SERVICE REPRESENTATIVE VOIDS THE WARRANTY

Operator's Trouble Shooting Guide

PROBLEM	POSSIBLE CAUSE	REMEDY/REFERENCE
Power indicator light does not turn ON when ON/OFF lever is in the ON position.	Power turned OFF at Main External Power Switch.	Turn ON power at Main External Power Switch.
	ON/OFF lever not fully turned to the ON position.	Turn lever to the ON position.
	Inoperative controls or indicators.	See Note 1
Power ON and appliance does not fill with water.	Water supply to appliance shut OFF.	Open water supply lines.
	Water line strainer and/or external filter system clogged.	Clean water supply strainer and/or filter system. See Yearly Maintenance.
	Water sensor is grounded by detergent film, or scale.	Clean water sensor assembly with vinegar solution. See Chapter 6.
	Inoperative controls or solenoids.	See Notes 1 and 5.
Control panel Power indicator is on, buzzer sounds continuously, Reset indicator is lit.	High limit has been tripped.	Reset steamer. If problem repeats, see Note1.
	Inoperative controls.	See Note 1.
Compartment bottom dirty with food drippings.	KleanShield™ not installed.	Install KleanShield™.
	Juices and/or food leaking from pans or spilling during loading and unloading.	Put a solid pan under perforated pans to catch drippings. Put less food in pans.
Control panel Power indicator light ON and steamer does not heat to cooking temperature or produce steam.	Door interlock switch not engaged.	Close door completely.
	Water supply to steamer closed.	Open water supply lines.
	Water line strainer and/or external filter system clogged.	Clean water supply strainer and/or filter system. See Yearly Maintenance.
	Appliance is in the Timed Mode and timer is not set (Dial timer models only.)	Change to manual mode or set the timer.
	High limit switch has tripped.	Reset steamer. See Chapter 3. If condition repeats, see Note 1.
	Bottom of reservoir is heavily scaled.	See Note 1 or 9.
Abnormal amount of steam coming from drain during draining of steamer. (Continued)	Inoperative controls.	See Note 1.
	ON/OFF lever/switch is not fully OFF.	Turn lever/switch to OFF to activate the drain cooling feature.
	Water line strainer and/or external filter system clogged.	Clean water supply strainer and filter system.

Continued on Next Page

**Operator's Trouble Shooting Guide
(Continued)**

(Continued) Abnormal amount of steam coming from drain during draining of steamer.	Hot water instead of cold water connected to reservoir fill line	See Note 2 and 3.
	Inoperative controls.	See Note 1.
Steam and/or water draining around the compartment door. See Warning under Note 7.	The vent, the drain to the vent, and/or the KleanShield™ opening is clogged or covered.	Clear vent and collector openings (Figure 2-2, 3-2). Clean the drain with NSF approved drain cleaner and flush drain thoroughly with fresh water. If condition persists see Note 1.
	Water Sensor dirty	Clean sensor thoroughly
	Door gasket or door parts worn.	See Note 1.
	Hot water instead of cold water connected to the condenser water line	See Note 2 and 3.
	External drain or vent not properly sized, installed, free air vented, and/or pitched down.	Make sure the drain is sized and installed properly. See Installation Manual. See Notes 2 and 3.
	Steamer not level.	See Note 2.
	Drain is blocked.	Clean drain with NSF approved drain cleaner. If problem persists see Note 1.
	Inoperative controls	See Note 1.
Steam coming out of the exhaust.	A small amount of steam may issue from the exhaust whenever the unit is in the cooking mode.	This is normal operation of the steamer NO action is necessary.
	Condenser water supply is turned OFF	Turn ON Condenser water supply
	Water line strainer and/or external filter system clogged.	Clean water supply strainer and/or filter system.
	Hot water instead of cold water connected to condenser supply line	See Note 2 and 3.
	Inoperative controls.	See Note 1.
Abnormal amount of steam coming from drain or vent.	Condenser water supply is turned OFF	Turn ON condenser water supply
	Hot water instead of cold water connected to the condenser water line	See Note 2 and 3.
	Condenser water line strainer clogged.	Clean water supply strainer. See Yearly Maintenance.
	Inoperative controls	See Note 1
Food takes too long to cook. To verify the steamers proper operation see Note 8.	Pans too close to the bottom of cabinet.	Put pans in racks near top of cabinet.
	Compartment overloaded with too much food.	Put less food into pan. Use fewer pans.
	Suggested cooking times are usually listed for cooking at sea level.	Extend cooking times for altitudes above 2500 feet.
	Convection fan inoperative	See Note 1.
	Bottom of steamer is scaled.	See Note 9
	Voltage too low for unit.	See Note 4.
	Inoperative controls.	See Note 1.

TROUBLESHOOTING NOTES

1. If the problem is inside the appliance, call a qualified Cleveland Range authorized service representative or Cleveland Range. (Please have the model number and serial number ready when calling.) Cleveland Range will not pay for warranty repairs by unauthorized maintenance and repair centers.
2. Proper installation of the appliance is the responsibility of the Owner-User. Refer to the Warranty.
3. Repairs to external plumbing must be done by a Licensed Plumber.
4. Repairs to external wiring must be done by a Licensed Electrician.
5. If the automatic fill system fails for any reason, the steamer will stop heating when the water level drops below the minimum operating level. The steamer can be operated by manually filling the water reservoir with about a gallon of water approximately every half-hour, until service can be performed.
6. For more information on products and services, contact your nearest Authorized Sales Representative. Call the factory for a preventative maintenance program, descaling information, and water treatment systems.
7. Whenever opening door, especially when water or steam is leaking around the gasket, heed the warning below.

 WARNING
BURN, SCALD AND EQUIPMENT DAMAGE HAZARD
If the drain is blocked, hot water can fill the cooking compartment and spill out when the cooking compartment door is opened. Signs of blocked drains include steam or water leaks around the cooking compartment door, and reduced cooking performance. To help avoid injury:
<ul style="list-style-type: none">• Stand on the hinge side and away from the appliance and slowly open the cooking compartment door.• Inspect the drain(s) before each use and clean them if needed. Failure to follow these precautions can cause burns, scalds, and equipment damage.

8. Use the Egg Test to evaluate steamer performance.
 - NOTE: this test is not valid for pressure steamers.
 - 1) Turn on the steamer, and set the selector switch to the manual mode (or for ON/OFF models set the selector to the ON position) so that steam is produced.
 - 2) Preheat the steamer for ten minutes.
 - 3) After the compartment is preheated, place a fresh egg on a perforated steam table pan in the middle of the cavity.
 - 4) Close the door and set the timer as directed by the size chart below

Egg Size	Time
Medium	12 minutes
Large	14 minutes
Extra Large	14 minutes

- 5) Carefully remove the egg and place in a container with cold water running over it.
 - 6) Let cool under cold running water for 5 minutes.
 - 7) After cooling, crack eggshell and peel.
 - 8) A properly operating steamer produces a perfect hard-boiled egg.
9. Although, a SteamChef Steamer normally should not require descaling, the use of extremely “hard” water or failure to follow the cleaning procedures in the Shutdown and Cleaning Instructions may cause scale buildup. Have Cleveland Range authorized technicians or trained onsite maintenance personnel descale the steamer.