

# SteamChef™ 3

Boilerless Convection Steamer, Automatic Water Fill & Drain,  
12 kW Boiler-Free Counter Type Design

Project \_\_\_\_\_  
Item \_\_\_\_\_  
Quantity \_\_\_\_\_  
FCSI Section 11400 \_\_\_\_\_  
Approved \_\_\_\_\_  
Date \_\_\_\_\_

High Efficiency Boilerless Steamchef™ Convection Steamers

## Models

- 22CET3.1



## Short Form Specifications

Shall be a Cleveland SteamChef™ 3, model 22CET3.1, one compartment high-speed electric convection steamer. \_\_\_\_ volt, \_\_\_\_ phase. Standard with SureCook Compartment Controls, 60-minute electro-mechanical timer with load compensating feature. Capacity for three 2.5" (1/1 G/N, 65 mm) full size steam table pans. 12kW electric heating elements in aluminum blocks. Includes 1/2" ball valve style automatic drain. Automatic water level controls. Heavy-duty 14 gauge stainless steel cooking compartment door and latch. KleanShield™ clean cavity protection. 4" Adjustable Legs



## Standard Features

- Cooking capacity for up to three 12" x 20" x 2.5" deep steam table pans (1/1 G/N, 65 mm).
- High-speed electric convection steamer with open style 1.0 gallon water reservoir located at the bottom of the cooking compartment for easy access and maintenance.
- Fan forced convection steam with patented KleanShield™ cooking compartment design. KleanShield™ collects and removes condensate waste from the cooking compartment. This keeps the compartment clean, safe from impurities and easy to maintain. Eliminates foaming and avoids contamination of the reservoir water.
- Automatic water level controls, fills when main power switch is turned ON, Low Water and High Water probes inside cooking compartment maintains water levels during cooking, eliminating the need to manually refill and monitor water level during cooking. Additional Safety Overflow Standpipe. 193° preheat and standby temperature. High Temperature Automatic Safety Shut-off.
- Steam and Fan Shut Off Control when compartment door is opened.
- 12 kW electric heating element encased in a solid aluminum block for fast and ultra efficient heat transfer. Element never needs deliming because it is not immersed in water.
- Exclusive SureCook Compartment Controls improves cooking speed and accuracy. New energy saving design reduces water and electric usage. On-demand power control for faster heat up and recovery. Energy saving Standby Feature when not in use. The SureCook timer automatically adjusts the cooking time with the volume of product being cooked, eliminating guesswork on when the product is finished. Includes a 60-Minute Electro-Mechanical Timer, LED Indicator Lights for SureCook Cycle, Power On and Reset. Timed and Manual Bypass Switch for constant steaming.
- Exclusive SteamChef™ Automatic Drain Control. Generator Drains when main power is turned OFF via 1/2" ball valve with micro switch circuitry. Simple 1 1/4" NPT drain connection required with water saving cold water condenser and 3 minute rinse feature.
- Left Hand Door Hinging: Compartment Doors hinged on the left, controls on the right.
- Exclusive, durable 14 gauge stainless steel compartment door and latch withstands abuse and heavy wear. Two piece compartment door with free floating inner door is self adjustable and prevents leaks. Reversible door gasket doubles the life of the gasket.
- Heavy-duty 4" (102mm) Skid Resistant Adjustable Legs with Flanged Feet.
- Meets agency codes: specifically UL and CUL listed, classified to NSF#4 and Energy Star.

## Options & Accessories

- 34" (864mm) High Stainless Steel Economy Stand, for one 22CET3.1 (UniStand34)
- 25" (610mm) High Stainless Steel Stacking Stand (UniStand25), for mounting two stacked 22CET3.1, includes 2" Stainless Steel Mounting Spacer
- POSK Pull-Out Shelf Kit for UniStands (P/N 111724)
- URK Pan Rack Kit UniStands (P/N 111726)
- Right Hand Door Hinging, Controls on Left (DHR)
- Electronic Timer
- 5 Foot (1524mm) FDA Approved National Hose Thread style water connection kit (garden hose thread), 2 required (NHT60)
- Single Point Water Connection (SPW)
- Single Phase Operation (see back)
- Optional Voltages, 480 Volt (VOS2), see back for alternative voltages.

- Each compartment has capacity for: Three, 12" x 20" x 212" deep Cafeteria Pans.
- Each compartment has capacity for: Six, 12" x 20" x 1" deep Cafeteria Pans.
- Each compartment has capacity for: Two, 12" x 20" x 4" deep Cafeteria Pans.

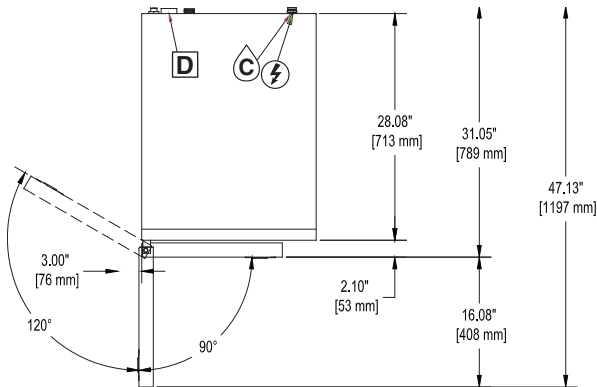

TOP VIEW

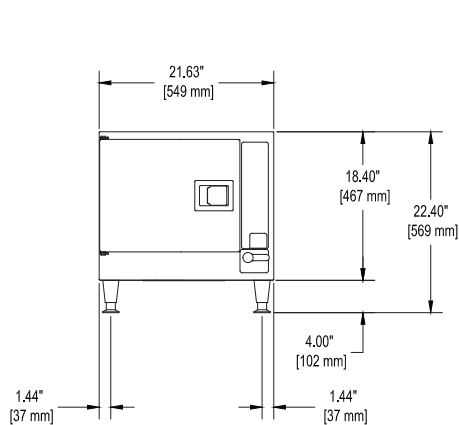

FRONT VIEW

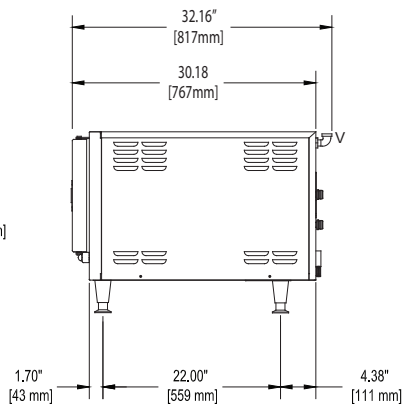

RIGHT SIDE VIEW

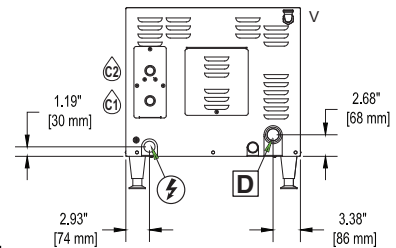

REAR VIEW

### COLD WATER

C1: Feed water for reservoir, 35 Psi Minimum, 60 Psi Maximum.  
 C2: Drain condenser water, 35 Psi Minimum, 60 Psi Maximum.  
 Two 3/4" NH-F (Garden Thread) connections. Use NSF approved hose.

### DRAIN CONNECTION

1 1/4" NPT-M  
 Do not connect other units to this drain.  
 Drain line must be vented.  
 Do not connect the appliance's drain connection to any drain material that cannot sustain 140°.

### VENT

V: Do not block or plug.

### OPERATING CLEARANCES

3" Left, 3" Right and 4" Rear.

### SERVICE CLEARANCES

12" on control side. Contact factory for variances to clearances.

### CONTROLS

SureCook 60-minute electro mechanical timer with load compensating feature.  
 Two function control switch for Timed Cooking and Continuous Steaming.

### APPROVALS

UL and cUL listed, classified to NSF#4 and Energy Star

### ELECTRICAL (Contact factory if installed above 3,500 feet)

WATTS	VOLTS	PHASE	WIRES	CYCLE HERTZ	AMPS	SUPPLY CONNECTION WIRE SIZE (COPPER)*
<b>Standard Wattage</b>						
<i>Three Phase - 12 kW Standard</i>						
10,725	208	3	3	60	29.8	8
12,000	220	3	3	60	31.5	8
14,280	240	3	3	60	34.4	8
10,085	440	3	3	60	13.2	12
12,000	480	3	3	60	14.4	12

WATTS	VOLTS	PHASE	WIRES	CYCLE HERTZ	AMPS	SUPPLY CONNECTION WIRE SIZE (COPPER)*
<b>Standard Wattage</b>						
<i>Single Phase - 12 kW Standard</i>						
10,725	208	1	2	60	51.6	6
12,000	220	1	2	60	54.5	4
14,280	240	1	2	60	59.5	4
10,085	440	1	2	60	22.9	10
12,000	480	1	2	60	25.0	8

\* For supply connection use only copper wire suitable for at least 75° C. (167° F).

### NOTES:

Cleveland Range reserves right of design improvement or modification, as warranted.  
 Many regional, state and local codes exist and it is the responsibility of the owner and installer to comply with the codes.  
 Cleveland Range equipment is built to comply with applicable standards for manufacturers. Included among those approval agencies.

(NOT TO SCALE)