

# Operators Manual

## Installation, Operation, Use & Care Steam Cooker and Rethermalization Unit



### Series: SteamChef<sup>®</sup> 3 Model 22CET3A Series

1333 East 179<sup>th</sup> Street  
Cleveland, Ohio 44110

Phone: (216) 481-4900  
Fax: (216) 481 3782

 Cleveland

## FOR THE USER

### FOR YOUR SAFETY

Do not Store or use gasoline or other flammable vapors or liquids in the vicinity of this or any other appliance.

### WARNING

Disconnect power before servicing

### WARNING

Improper installation, adjustment, alterations, services or maintenance can cause property damage, injury or death. Read the installation, operating and maintenance instructions thoroughly before installing or servicing this equipment.

## IMPORTANT

ALL SERVICE MUST BE PERFORMED BY A QUALIFIED CLEVELAND RANGE TECHNICIAN.

RETAIN THIS MANUAL FOR YOUR REFERENCE

Operators and Installation Manual  
 SteamChef™ 3 Steam Cooker and Rethermalization Unit  
 Table of Contents

<b><u>CHAPTER</u></b>	<b><u>PAGE</u></b>
<b>CHAPTER 1. INTRODUCTION .....</b>	<b>1</b>
<b>A. OPERATIONAL SAFETY.....</b>	<b>1</b>
<b>B. PRODUCT INFORMATION .....</b>	<b>2</b>
1. Model Number.....	2
2. Serial Number .....	2
3. Product information Plate .....	2
4. “SteamChef™ 3” Model No. 22CET3A Product View .....	3
<b>CHAPTER 2. OPERATION .....</b>	<b>4</b>
<b>A. GENERAL OPERATION .....</b>	<b>4</b>
1. Main External Power Switch .....	4
2. Door Interlock Switch .....	4
3. KleanShield™ .....	4
4. Inspecting the Cooking Compartment .....	5
5. Power ON (Auto Water Fill/Automatic Preheat) .....	6
6. Preheating the Steamer.....	6
7. High Limit Reset .....	6
8. Energy/Water Saver Feature .....	6
<b>B. CONTROL PANELS .....</b>	<b>7</b>
1. Dial Timer Control Panel .....	7
a. General Operation.....	7
b. Manual and Timed Modes .....	7
(1) Manual Mode .....	7
(2) Timed Modes .....	7
2. “ON/OFF” Control Panel .....	8
a. Cooking Operations – ON/OFF Control Panel .....	8
b. Operating the ON/OFF Control .....	9
<b>C. COOKING WITH THE STEAMCHEF™ 3 .....</b>	<b>9</b>
1. Operating and Cooking Procedure – Timed Cook Mode .....	10
2. Operating Procedure – Manual Mode .....	11
3. Using the SteamChef™ 3 to Rethermalize Food .....	12
<b>D. SHUTDOWN AND CLEANING PROCEDURE.....</b>	<b>13</b>
<b>CHAPTER 3 – PREVENTATIVE MAINTENANCE AND TROUBLESHOOTING.....</b>	<b>14</b>
<b>A. MAINTENANCE.....</b>	<b>14</b>
1. Maintenance Records.....	15
2. Daily Maintenance.....	15
a. Checking and Changing the Water.....	15
b. Cleaning the Steamer.....	15
3. Yearly Maintenance – Cleaning the Water Strainers .....	15
<b>B. OPERATORS TROUBLESHOOTING GUIDE.....</b>	<b>16</b>
<b>CHAPTER 4 – INSTALLATION.....</b>	<b>19</b>
<b>A. GENERAL.....</b>	<b>19</b>
<b>B. INSTALLATION OF THE STEAMCHEF™ 3 .....</b>	<b>19</b>

(Continued on Following Page)

## Table of Contents (continued)

<b><u>CHAPTER</u></b>	<b><u>PAGE</u></b>
1. Locating the Steamer.....	20
Location and Clearance Requirements of the Steamer .....	20
2. Installation Using Cleveland Range Stand Model No. ES222834 .....	21
3. Installation of SteamChef™ Steamers on the Model No. ES222824S Sacking Stand .....	22
4. Installing the Legs .....	24
5. Positioning and Leveling the Steamer .....	25
6. Installation of the KleanShield™ .....	25
7. Installing the Fan Guard .....	25
8. Install Slide Racks and Rear Vent .....	25
9. Install the Free Air Vented Drain Lines .....	26
10. Water Supply Requirements and Installation .....	27
a. Water Supply Requirements .....	27
b. Install Water Supply Lines .....	27
c. Testing Water Supply Lines .....	29
11. Install Electric Power Lines.....	29
<b>C. STARTUP AND CHECKOUT.....</b>	<b>30</b>
1. Installation Checkout .....	30
<b>Notes on Installation</b> .....	<b>30</b>
2. Operating Test and Final Checkout Procedure.....	31
a. Startup Procedure.....	31
b. Drain Rinse Inspection .....	32
c. Operating Tests and Final Checkout Procedure (Sequence of Operation) .....	32
<b>CHAPTER 4 – STEAM COOKING GUIDE .....</b>	<b>35</b>
<b>A. INTRODUCTION .....</b>	<b>35</b>
<b>B. SIZING UP PAN CAPACITY .....</b>	<b>36</b>
1. Serving Sizes – How Much? How Many? .....	36
2. Reference Charts for Typical Pan Capacities .....	36
<b>C. CONVECTION STEAMER – SUGGESTED TIMER SETTING GUIDELINES .....</b>	<b>37</b>
<b>D. STEAMING TIPS – LOBSTER – CRAB - SHRIMP .....</b>	<b>39</b>
1. Live Lobster and Crabs .....	39
2. Lobster Tail 8 oz. ....	39
3. King Crab Legs .....	39
4. Shrimp .....	39

# CHAPTER 1 – INTRODUCTION

To use a SteamChef™ 3 steamer safely and effectively, each operator must read and understand this section completely before starting operation. The owners and operators of the steamer should retain these instructions in an easily accessible location for future reference and training.

The owner(s) and operator(s) of the steamer must be aware that steam can cause serious injuries and equipment damage. Pay particular attention to the Operational Safety section of this chapter, and the WARNINGS and CAUTIONS displayed in this manual and on the equipment.

## WARNING

**DO NOT ATTEMPT TO START OR OPERATE a SteamChef™ 3 steamer during a power outage.**

**DEATH, INJURY, AND EQUIPMENT DAMAGE could result from the improper installation of a steamer.**

Before starting a recently installed or repaired steamer, be sure it has been installed by qualified personnel according to the instructions found in CHAPTER 4 of this Manual.

### A. OPERATIONAL SAFETY

The safe and effective operation of any steamer depends upon proper installation, use, maintenance, and repair. Operational safety must encompass all of these factors. This Operational Safety section outlines the minimum safety policies that should be considered when using one or more SteamChef™ 3 steamers. It is assumed that any operational safety program must be tailored to the specific site and use of the equipment.

Burn hazards are present in any professional food service operation. When using the steamer, observe the following precautions.

- The SteamChef™ 3 is a constantly cooking appliance and is in some cooking or standby mode whenever it is turned ON. As such parts of this appliance will **ALWAYS BE HOT**.
- Remember at all times that steam can cause severe burns.
- Never operate a SteamChef™ 3 steamer without the KleanShield™ properly installed in the bottom of the water reservoir or the fan guard installed over the fan.
- When checking inside the steamer always open the door slowly and stand to the side and back away from the steamer.
- Open the door slightly to allow steam to vent before looking or reaching into cooking compartment.
- Do not reach into the cooking compartment until the steam has cleared and the cooking fan has ceased rotating.
- Do not reach into steamer or handle hot items without wearing heatproof gloves. Wet or damp gloves conduct heat, and may cause burns when touching hot items.
- Do not use anything but your hands to operate the controls of the steamer.
- Do not block the vents on the side or rear of the unit or obstruct the flow of ventilation air to the steamer. Do not store articles on top of the unit.
- Do not ever tilt the unit if the main external power to the unit is on, or if the drain is closed.

The steamer requires a minimum of service if properly operated and maintained by trained personnel. The following steps will help keep the steamer in a safe, efficient operating condition.

1. Do not store or leave combustible materials near the steamer. Keep the area around and under the steamer free of combustible materials.
2. Non slip draining mats should be on the floor in front of the steamer to prevent slipping accidents from spilled water.
3. Train all personnel who will use the steamer. Make sure personnel know how to operate the steamer, clean the interior and exterior, and drain the unit.

4. Operating personnel must be able to recognize problems, and report them so that corrective actions can be taken by trained personnel as outlined in the troubleshooting charts found in Chapter 3 of this manual.
5. Conduct regular steamer inspections. Check for water line leaks, door seal, drain and drain valve leaks, clogged drain or KleanShield™, dirty water level sensors, and steamer control malfunctions.
6. Follow the instructions for steamer maintenance found in this manual.
7. Remove spilled food from the surface of the KleanShield™ and the inside of the steamer reservoir. Never push solid food remnants down the KleanShield™ opening or the reservoir drain opening.
8. Before each use of the steamer, inspect the drain and KleanShield™ for blockage. Inspect the door gasket assembly, water level sensors, KleanShield™, fan guard and slide racks for proper installation and cleanliness.
9. Allow only Cleveland Range authorized service representatives to service the steamer.
10. Use only factory authorized repair parts.
11. Maintain written records of steamer maintenance and service. Each record should include at least:
  - The date of the service or maintenance.
  - A description of the service, maintenance or repair performed. Include part numbers if applicable.
  - Copies of purchase order(s) and invoice(s) for repair parts and service.
  - The name and signature of the person performing the maintenance or service.

## B. PRODUCT INFORMATION

Cleveland Range, LLC assigns two product identification numbers to each steamer: a model number and a serial number. The model number identifies the product characteristics. The serial number identifies the individual unit. The Model Number and Serial Number are also located on the control panel as well as the product information plate for your convenience in accessing this information.

### 1. Model Number

This manual covers the SteamChef™ 3 Model No. 22CET3A Steam Cooker and Rethermalizer. Each character of this model number identifies a characteristic of the steamer. The SteamChef™ 3 Model No. 22CET3A is **22** inches wide, is a **C**onvection Steamer, an **E**lectric **T**abletop Model, cooks up to **3** standard 2 ½” pans of food and **A** equipped with **A**uto fill/drain option. This manual covers all standard features and options available on SteamChef™ 3 electric steamers.

Other than selection of options, there are presently no significant design, parts, or operating differences among steamers with this model number. Figures 1-2 and 1-3 illustrate the major external features.

### 2. Serial Number

During manufacture, SteamChef™ 3 Steamers are assigned individual serial numbers. Whenever any inquiry is made with Cleveland Range regarding a steamer the serial number should be referenced.

### 3. Product Information Plate

The Product Information Plate on the rear of the unit lists the model and serial number as well as the power and wiring requirements of the steamer. Refer to Figure 1-3 for the location of the plate. Figure 1-1 illustrates a typical SteamChef™ 3 Product Information Plate.

CLEVELAND RANGE, LLC CLEVELAND, OHIO							
Model No. 22CET3A				Serial No. WC 12272-02D-01			
VOLTS	PH	WIRES	HZ	WATTS	AMPS	SUPPLY A.W.G.	
240	3	3	60	9400	22.6	8	


 CAUTION: FOR SUPPLY CONNECTION USE ONLY COPPER WIRE  
 SUITABLE FOR AT LEAST 75 °C  
 ATTENTION: EMPLOYER DES FILS D'ALIMENTATION ADEQUATS  
 POUR 75 °C  
 COMMERCIAL COOKING APPLIANCE 1017702 B

Figure 1-1 SteamChef™ 3 Product Information Plate

4. "SteamChef™ 3" Model No. 22CET3A Product Views

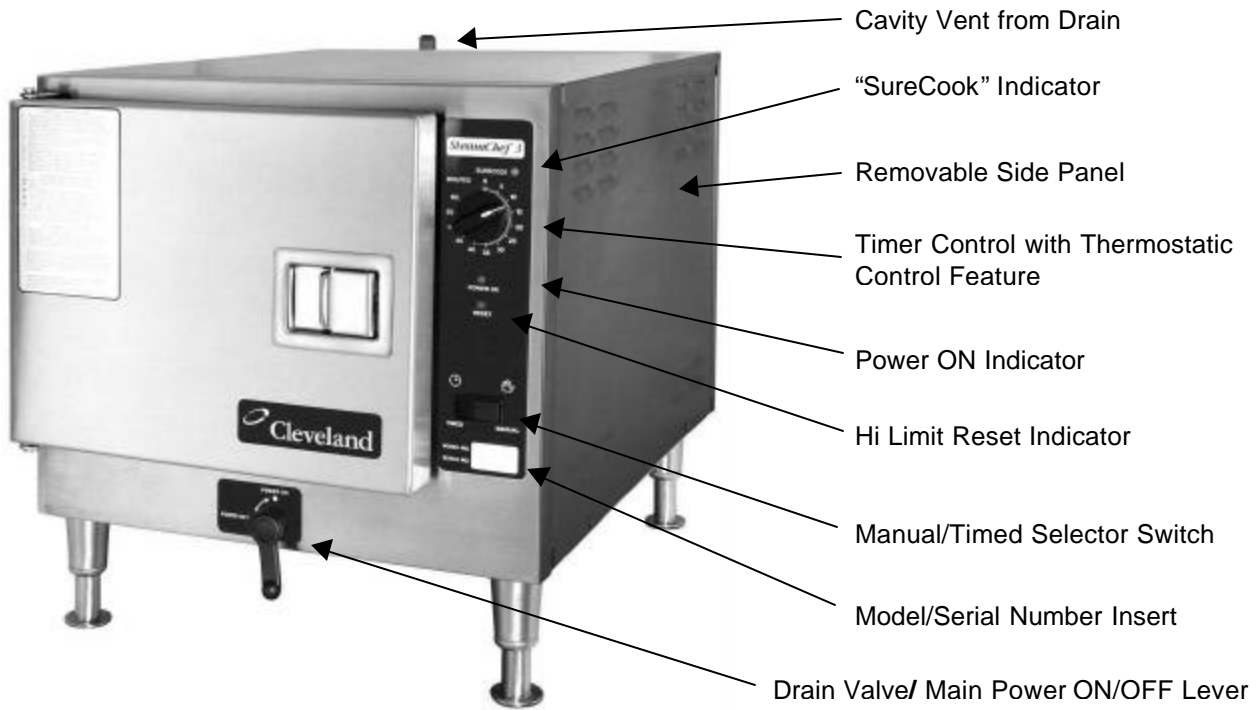


Figure 1-2 SteamChef™ 3

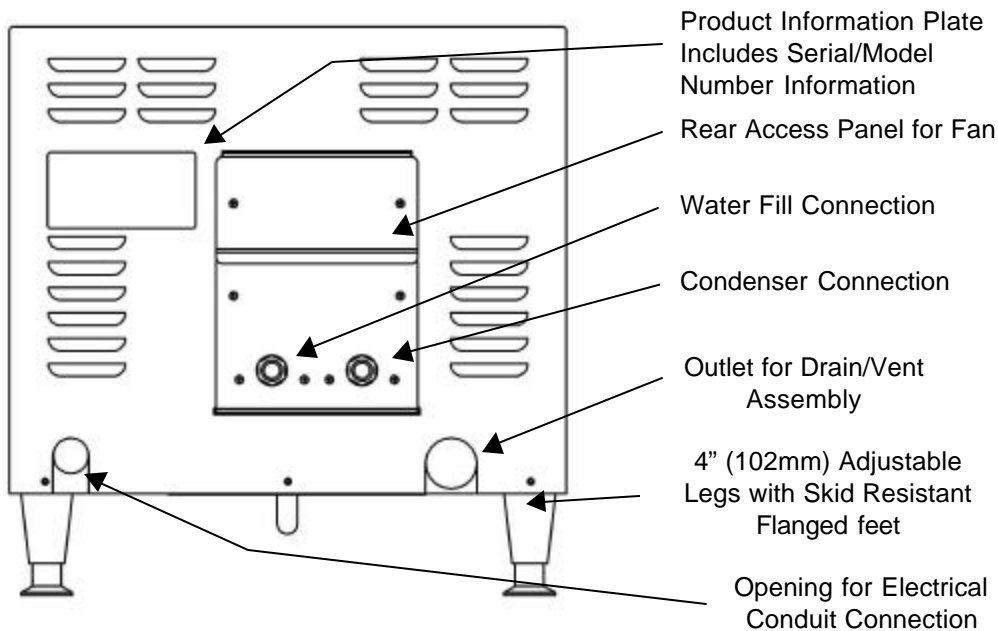


Figure 1-3 SteamChef™ 3 Steam Cooker Rear View

## CHAPTER 2 – OPERATION

### A. GENERAL OPERATION

#### 1. Main External Power Switch

Usually the steamers main external power switch is left ON. If the main power switch was left in the OFF position, turn it ON as follows.

- a. Turn the ON/OFF lever/switch to the OFF position.
- b. The control settings are not important in this procedure. The control panel circuits are not powered while the ON/OFF lever/switch is set to OFF.
- c. Refer to the main power switch in Figure 2-1, and turn on electric power to the steamer.

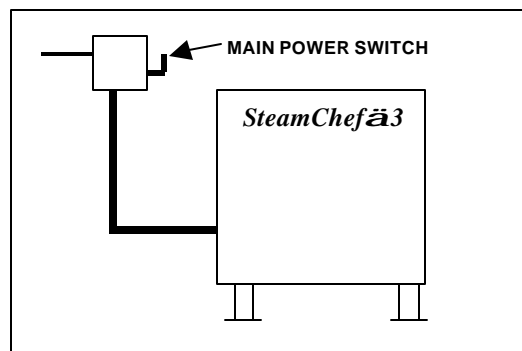


Figure 2-1 Main Power Switch

#### 2. Door Interlock Switch

The steamer compartment of the SteamChef™ 3 is equipped with an automatic steam cutoff switch, which turns OFF the production of steam and shuts down the convection fan and condenser whenever the door to the compartment is opened. **NOTE:** That even though the continued production of additional heat ends as soon as the door is opened, it may take up to a minute for residual heat in the system to stop producing steam in the cooking compartment and for the fan to stop rotating. To avoid possible injury always wait until this residual steam has cleared and the convection fan has stopped rotating before reaching into the cooking compartment. **Remember the SteamChef™ 3 is always heating in either the standby heat mode or steam cooking mode, whenever the main power switch is in the ON position and the steamer door is closed.**

#### 3. KleanShield™

This unit is equipped with the KleanShield™ for improved maintenance, cooking and safety performance in the steam cooking of food. The KleanShield™ (See Figure 2-2) is located in the bottom of the water reservoir of Cleveland Range SteamChef™ Cookers and provides the following benefits to the owner/operator:

- By collecting all of the drippings of food being cooked from entering and contaminating the reservoir water.
- By keeping the water cleaner, less maintenance is needed in the daily operation and cleaning of the interior of the steamer.
- It directs the steam being produced around the sides of the pans to insure more even distribution of the steam.
- It prevents the operator from accidentally coming in contact with the reservoir water during the placing or removal and food from the cooking compartment.
- It also prevents spilled food from pans from falling directly into the reservoir and splashing out scalding water.
- The KleanShield™ is removable and dishwasher safe allowing for easy cleaning.



Figure 2-2 the KleanShield™

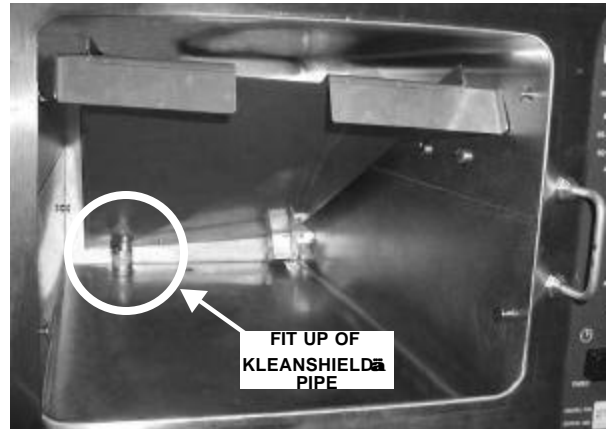
**Please read** the following Important Use and care Instructions for the KleanShield™

- a. Never operate a SteamChef™ Steamer without a properly installed KleanShield™.
- b. To install the KleanShield™, the side pan racks must first be removed from the steamer.

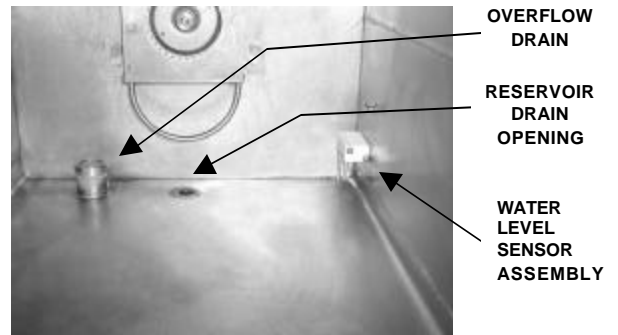
- c. Place the KleanShield™ into the steamer with pipe extension towards the back and facing down. Set the KleanShield™ in place over the corresponding pipe extending out of the bottom of the steamer reservoir. See Figure 2-3.
- d. The KleanShield™ is installed properly when the pipe from the KleanShield™ is fitted into the corresponding pipe in the bottom of the steamer and its legs are flush against the bottom of the steamer. See Figure 2-6.

**4. Inspecting The Cooking Compartment**

- a. Before turning ON the power switch/lever to the SteamChef™ 3, the entire inside of the steamer must be thoroughly cleaned.
- b. All food debris should be wiped clean and the drain openings and the water level sensors shall be inspected and cleaned of any residue or debris (See Figure 2-4).
- c. The door gasket assembly, KleanShield™, fan guard and slide racks should be inspected for proper installation and cleanliness. See Chapter 2, Section A, Part 3 for proper installation of the KleanShield™.
  - To properly install the fan guard, hold the fan guard so that the large ends of the keyholes are towards the bottom of the steamer. Place all four openings over the mounts located on the rear wall of the steamer and pull it down so that the narrow ends of the slots are pulled tight over the mounts. See Figure 2-5.

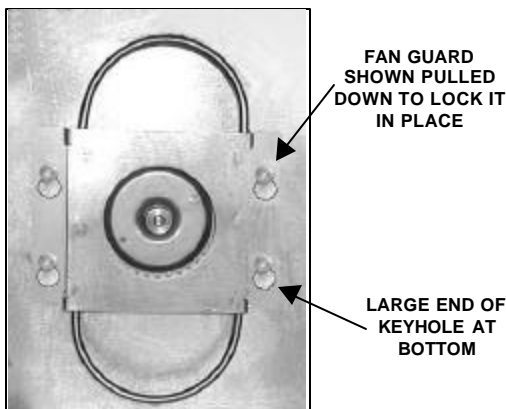


**Figure 2-3 KleanShield Installation**

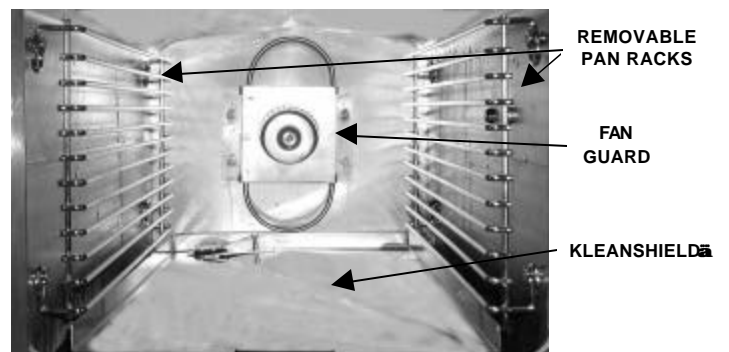


**Figure 2-4 Inspecting Compartment drains**

- d. Make sure that the KleanShield™ drain is clear. See Figure 2-6.
- e. It is also recommended that a small amount of water (about a quart) be poured through the KleanShield™ drain. Check that water flows out the drain.



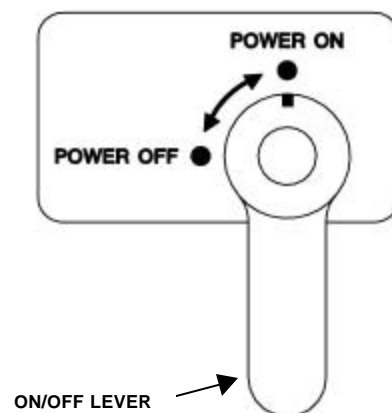
**Figure 2-5 Fan Guard Shown in Installed Position**



**Figure 2-6 Inspecting Compartment Interior Accessories**

## 5. Power ON (Auto Water Fill/Automatic Preheat)

- a. Check that the water supply valves to the unit are open.
- b. Set the timed manual switch to timed (dial timer models) or set the selector switch to OFF (ON/OFF control models).
- c. Turn ON power to the steamer by turning the drain valve lever clockwise (down) to close the drain (see Figure 2-7). The power ON indicator will light and the unit will begin to fill automatically.
- d. Close the door. Once the unit has filled to the minimal operating level the heater will come ON, and the steamer will begin to automatically heat the water supply to the standby cooking temperature.
- e. When the 'SureCook' indicator light goes off the steamer has completed its Preheat (this only applies for units equipped with a timer). For ON/OFF control units it will take approximately 10 to 15 minutes for the unit to reach the standby heating temperature depending on the wattage of the Steamer and the incoming temperature of the water.



**Figure 2-7 ON/OFF Lever**  
(Shown in ON Position)

## 6. Preheating The Steamer

Preheating the steamer can help insure that the best productivity and consistent cooking is obtained. To preheat the SteamChef™ 3, simply turn the unit on approximately 15 minutes before you are ready to cook. The unit will automatically go into the preheat mode and prepare the unit for cooking.

- **BEFORE PREHEATING**, inspect and clean the compartment. After preheating, the compartment will be too hot to inspect and clean safely.

## 7. High Limit Reset

This unit is protected by a high limit lockout, which acts to protect the unit from overheating. If the reset light should come ON, a buzzer will sound continuously, the heating circuit of the steamer will be locked out by the over-temperature circuit, and the steamer will not be able to be used for cooking until the unit is reset. To reset the high limit use the following procedure:

- a. If the reset indicator lights, turn OFF power to the unit at the ON/OFF lever.
- b. Wait 15 minutes for the unit to cool and refill the unit with water according to the Power ON instructions found in Chapter 2, Section A, Part 5.
- c. If the condition should repeat itself see the operators troubleshooting section of this manual, Chapter 3, Section B for further instructions.

## 8. Energy/ Water Saver Feature

This unit is equipped with an internal timer system, which automatically switches the unit to the standby heat temperature if the unit is left in the Manual Mode (timer models) or the unit is left ON (ON/OFF Control Models) for more than 60 minutes without opening the door. This feature has the following benefits:

- It saves water by reducing steam loss and condenser water.
- By maintaining a lower temperature and not constantly producing steam, energy usage is reduced.
- Increases the steamer life.
- Because the unit automatically returns to the cooking temperature the next time the door is opened, this feature has almost no effect on the operation of the equipment.

## **B. CONTROL PANELS**

The standard dial timer control panel (illustrated in Figure 2-8) has a mechanical timer that uses a “SureCook” temperature compensation circuit, which allows the timer to count down only while the cooking compartment is at cooking temperature. An optional ON/OFF control panel (illustrated in Figure 2-9) is also available. The ON/OFF Control Panel, operates exactly like the dial timer control model in manual mode, except a selector switch is used to change the steamer from the standby heat mode to the cooking mode.

### **1. Dial Timer Control Panel**

#### **a. Cooking Operations – Dial Timer Control Panel**

For safe, efficient operation of the steamer, the operator must, at a minimum, comply with all cautions, warnings and instructions in the detailed operating procedures and be familiar with the control panel shown in Figure 2-8. The operator must be familiar with all the operating features explained in this manual before attempting to operate the steamer.

#### **b. Manual and Timed Modes**

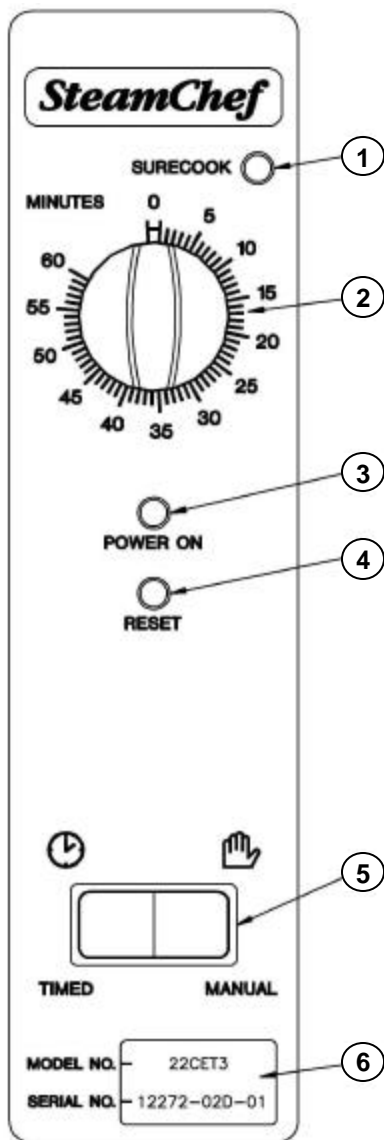
The steamer has two operating modes: manual and timed. The TIMED/MANUAL rocker switch selects the operating mode. Pressing the MANUAL end of the switch selects the manual operating mode. Pressing the TIMED end of the switch selects the timed operating mode. Cooking procedures are slightly different for each mode.

##### **1). Manual Mode**

The manual mode provides continuous steaming operation. The operator starts and stops steaming operations manually. See the Operating and Cooking Procedure – Manual mode in Chapter 2, Section C, Part 2 for more information. A thermostat controlled “SureCook” indicator light located on the control panel indicates that the cooking compartment has not yet reached optimum cooking temperature.

##### **2). Timed Mode**

- The timer provides timed control of steaming operations. The timer starts and stops steaming operations.
- The mechanical timer control uses a “SureCook “ temperature compensation circuit that effects only the timer. When operating, the timer ONLY COUNTS DOWN WHILE THE COOKING COMPARTMENT IS AT AN EFFICIENT COOKING TEMPERATURE. This provides totally automatic control of the steaming operation and assures uniform cooking as the timer automatically compensates for food product defrosting and/or compartment heat up time. Whenever the steamer is not at an efficient cooking temperature, the compensation feature interrupts the countdown of the timer and the ‘SureCook” light is illuminated.
- To use the timer, simply set the timer to the desired time. The steamer will begin cooking as soon as the timer is set. When the timer reaches zero the steaming functions will automatically end and a buzzer will sound for 3 seconds to alert the operator that cooking is complete. The cooking compartment will then revert to the standby-heating mode until the next timing cycle is started.
- Note the mechanical timer will not function when the Timed/Manual switch is set to Manual, although the ‘SureCook” light will still illuminate to indicate that the cooking compartment is not yet at optimum cooking temperature.



1. “SureCook” Indicator Light

This Amber light is lit whenever the cooking compartment has not yet reached the optimum cooking temperature. Note: when in the timed mode the timer will not count down as long as this light is ON.

2. TIMER

This dial timer sets the operating time from 0 to 60 minutes. Turn the dial clockwise until it points to the required number of minutes. When it reaches 0, a buzzer sounds for 3 seconds.

3. POWER ON Indicator Light

When the Green indicator light is ON, power is ON to the operating controls.

4. RESET Indicator Light

When this light is lit, it indicates that the high limit circuit of the steamer has opened. This light will remain ON, and a buzzer will sound until power to the unit has been reset. See High Limit Reset in Chapter 2, Section A, Part 7 for additional details.

5. TIMED/MANUAL Switch

The TIMED/MANUAL switch selects the manual or timed operating mode.

- Pressing the MANUAL end of the switch selects the manual mode.
- Pressing the TIMED end of the switch selects the timed mode.

6. Serial Number/Model Number Display

**Figure 2-8 Dial Timer Control Panel**

**2. ON/OFF Control Panel**

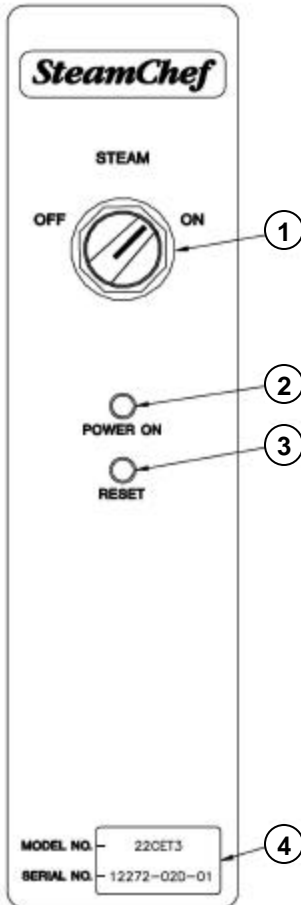
**a. Cooking Operations – ON/OFF Control Panel**

For safe, efficient operation of the steamer, the operator must, at a minimum, comply with all cautions, warnings and instructions in the detailed operating procedures and be familiar with the control panel shown in Figure 2-9. The operator must be familiar with all the operating features explained in this manual before attempting to operate the steamer.

### b. Operating the ON/OFF Control

This unit leaves all control of the cooking up to the operator. When turned ON cooking with this steamer is the same as cooking with a dial timer control unit in the Manual Steam Mode.

NOTE: This unit is constantly in a hot mode whenever the main power lever is ON, the door is closed and the unit is filled with water. When the selector switch of this unit is turned to the OFF position, this unit will maintain the Standby Heat temperature in the compartment.



#### 1. ON/OFF Selector Switch

When turned to the ON position the steamer will go into the Constant Steam Mode and maintain the compartment temperature at the cooking level for 1 hour unless the door is opened. When turned to the OFF position the unit will be maintained at the standby heating temperature.

#### 2. POWER ON Indicator Light

When the Green indicator light is ON, power is ON to the operating controls.

#### 3. RESET Indicator Light

When this light is lit, it indicates that the Hi-limit circuit of the steamer has opened. This light will remain ON, and a buzzer will sound until power to the unit has been reset. See High Limit Reset in Chapter 2, Section A, Part 7 for additional details.

#### 4. Serial Number/Model Number Display

**Figure 2-9 On/Off Control Panel**

### C. COOKING WITH THE STEAMCHEF<sup>™</sup> 3

#### **IMPORTANT**

The SteamChef<sup>™</sup> 3 is a continuously operating appliance and is constantly standing by and ready to cook whenever the ON/OFF lever of the power control panel is in the ON position.

**⚠ WARNING**

When checking inside the steamer always open the door slowly and stand to the side and back away from the steamer. Water leaking from the door gasket can be a sign of a blocked drain. If the drain is blocked, hot water can accumulate inside the compartment and spill out when the door is opened.

**1. Operating and Cooking Procedure – Timed Cook Mode**

**⚠ WARNING**

Even though the heating elements are de-energized as soon as a door is opened, it may take up to a minute for production of steam to end and residual steam in the system to clear from the cooking compartment. To avoid possible injury always wait until this residual steam has cleared before reaching into the cooking compartment.

Never operate a SteamChef™ 3 Steamer without the KleanShield™ properly installed in the bottom of the water reservoir or the fan guard installed over the fan.

In timed mode, the timer starts and stops the cooking operation. When in the timed mode and the compartment door is closed, the unit will maintain the compartment at the standby heat temperature whenever the unit is not performing a timed cook operation.


- (1) Refer to Inspecting the Cooking Compartment in Chapter 2, Section A Part 4. Inspect and clean the drain, KleanShield™ and cooking compartment as required.
- (2) Refer to the Power ON instructions in Chapter 2, Section A, Part 5 and turn ON and fill the unit.
- (3) If necessary, refer to Preheating the Steamer, in Chapter 2, Section A Part 6, and preheat the cooking compartment.
- (4) Slide the pans of food into the slide racks inside the steamer. Do not place pans or anything else on the bottom of the compartment.

**⚠ CAUTION**

Some foods drip juices and food debris. Use a solid catch pan under perforated pans when steaming food that will drip excessive juices and debris. Failure to use a catch pan can cause a clogged drain or KleanShield™.

- For best cooking results, use shallow, 2-1/2 inch deep, perforated pans without covers. These give the best heat transfer and shortest cooking time.
- (5) Close the steamer door.
  - (6) Check the control panel settings. At this point the settings should be:
    - The ON/OFF Lever is in the ON (down) position and the Power indicator light is lit.
    - The TIMED/MANUAL switch is in the TIMED (left) position.

- (7) Set the required cooking time. The timer will start counting down as soon as the compartment reaches the minimum cooking temperature.
- (8) When the timer reaches zero, a buzzer will sound for 3 seconds; the cooking circuit will turn OFF and the unit will revert to the standby heat mode. The cooking cycle is complete.

 <b>WARNING</b>
<p><b>SEVERE BURNS may result from exposure to steam.</b></p> <p><b>Do not open the steamer door before steam generation stops. Stand back when opening the compartment door. Open the door slightly to allow steam to vent before looking or reaching into cooking compartment. Do not reach into cooking compartment until the steam has cleared.</b></p> <p>Do not reach into steamer or handle hot items without wearing heatproof gloves. Wet or damp gloves conduct heat, and may cause burns when touching hot items.</p>

- (9) Carefully open the cooking compartment door, and remove the pans from the slide racks.
  - If the steamer will be used again shut the door to maintain the cooking compartment temperature.
  - If the steamer is not being used again during this shift, perform the Shut Down and Cleaning Procedures, found in Chapter 2, Section D.


## 2. Operating and Cooking Procedure – Manual Mode

Manual mode allows the operator to personally control the cooking functions. The operator starts and stops the steaming operations, and sets the cooking time including time for cooking compartment and food heat-up time. Use the manual-cooking mode for:

- A continuous supply of steam.
- Maintaining the compartment temperature between cooking batches.
- Remember that this unit is equipped with an energy saving feature. This automatically drops the compartment into the standby heat mode, after an hour of operating in the manual mode without interruption (such as opening the door). If Cooking times longer than the 60 minutes are desired, it will be necessary to reset this timer circuit. To reset the timer without interrupting the continuous cooking of the unit either quickly open and close the cooking compartment door, or switch the TIMED/MANUAL switch to timed and back to manual.

### Manual Cooking Procedure

Follow this procedure when cooking with the steamer in manual mode.

 <b>WARNING</b>
<p>Even though the heating elements are de-energized as soon as a door is opened, it may take up to a minute for production of steam to end and residual steam in the system to clear from the cooking compartment. To avoid possible injury always wait until this residual steam has cleared before reaching into the cooking compartment.</p> <p>Never operate a SteamChef™ 3 Steamer without the KleanShield™ properly installed in the bottom of the water reservoir or the fan guard installed over the fan.</p>

- (1) Inspect and clean the drain and cooking compartment as required. Refer to Inspecting the Cooking Compartment in Chapter 2, Section A, Part 4.
- (2) Refer to the Power ON instructions in Chapter 2, Section A, Part 5 and turn ON and fill the unit.
- (3) In manual mode, the operator can bring the compartment to cooking temperature by either preheating or increasing the cooking time. If the operator chooses to preheat the cooking compartment manually, refer to Chapter 3, Section A, Part 6, Preheating The Steamer.
- (4) Slide the pans of food into the slide racks inside the steamer. Do not place pans or anything else on the bottom of the compartment.

 **CAUTION**

Some foods drip juices and food debris. Use a solid catch pan under perforated pans when steaming food that will drip excessive juices and debris. Failure to use a catch pan can cause a clogged drain or KleanShield™.

- For best cooking results, use shallow, 2-1/2 inch deep, perforated pans without covers. These give the best heat transfer and shortest cooking time.
- (5) Close the steamer door. Select the manual mode by pressing the MANUAL end of the TIMED/MANUAL rocker switch. The steaming cycle starts as soon as the switch is pressed. Shortly after the door is closed, steam fills the cooking compartment.
  - (6) To stop manual mode steaming, press the TIMED end of the TIMED/MANUAL rocker switch and verify that the timer is at zero. The cooking circuit is de-energized, and steam flow to the cooking compartment gradually stops.

 **WARNING**

**SEVERE BURNS may result from exposure to steam.**

**Do not open the steamer door before steam flow stops. Stand back when opening the compartment door. Open the door slightly to allow steam to vent before looking or reaching into cooking compartment. Do not reach into cooking compartment until the steam has cleared.**

Do not reach into steamer or handle hot items without wearing heatproof gloves. Wet or damp gloves conduct heat, and may cause burns when touching hot items.

- (7) Carefully open the cooking compartment door, and remove the pans from the slide racks.
  - If the steamer will be used again shut the door to maintain the cooking compartment temperature.
  - If the steamer is not being used again during this shift, perform the Shut Down and Cleaning Procedures, found in Chapter 2, Section D.

### 3. Using the SteamChef™ 3 to Rethermalize Food

The SteamChef™ may also be used to reheat/rethermalize previously cooked and/or refrigerated foods to serving temperature in minutes. To use the SteamChef™ 3 to rethermalize food, use the following procedure:

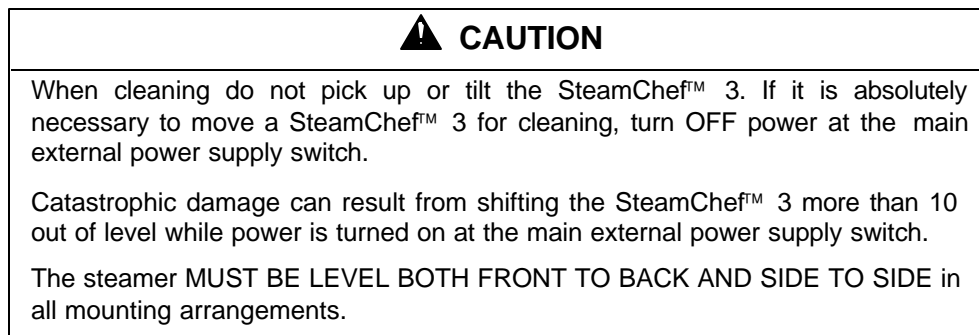
- Use the SteamChef™ 3 in the Manual Cooking Mode as outlined in Chapter 2, Part C, Section 2 and cook the food to a safe serving temperature, 160-170 °F for most foods.

- Depending on initial food temperature and density, most foods should be rethermalized to a serving temperature in 10 to 40 minutes.
- Always check internal temperature of food with a thermometer to determine when it has been rethermalized to a safe temperature (160° to 170°F).
- Remember that this unit is equipped with an energy saving feature. This automatically drops the compartment into the standby heat mode, after an hour of operating in the manual mode without interruption (such as opening the door). If Cooking times longer than the 60 minutes are required to rethermalize a particular load of food, it will be necessary to reset this timer circuit. To reset the timer without interrupting the continuous cooking of the unit either quickly open and close the cooking compartment door, or switch the TIMED/MANUAL switch to timed and back to manual

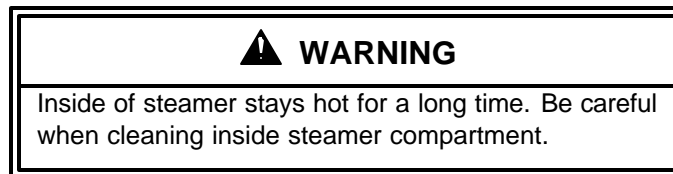
**NOTE:** Cooking times may be longer for some foods and/or larger loads, especially when using 6 kW SteamChef™ 3 models.

#### D. SHUTDOWN AND CLEANING PROCEDURE

This procedure should be performed at the end of each day or shift.



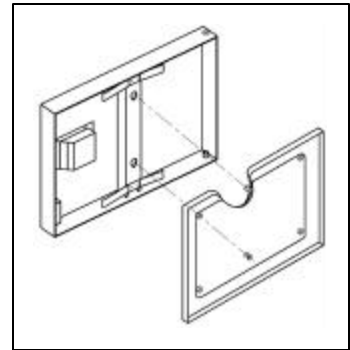
1. Open the steamer door and allow steamer to cool.
2. Turn the ON/OFF lever counter-clockwise (up) so that the white reference marker on the lever is pointing directly left to turn the power OFF, de-energize all controls and drain the steamer. The steamer will begin a 3-minute drain rinse cycle to clean the drain system.



3. Remove any spilled food from the surface of the KleanShield™. Never push solid food remnants down the KleanShield™ opening or the reservoir drain opening.
4. Remove the slide racks, fan guard and KleanShield™. Wash and rinse slide racks, fan guard and KleanShield™ separately or clean them in a dishwasher according to health requirements.
5. Remove any spilled food from inside compartment and clear any residue from the drain valve and the KleanShield™ drain opening. Clean the interior of the compartment thoroughly, to remove all


food particles. Use a soft bristle brush to clean the water sensor, temperature probe and to remove stubborn food particles. Do not use abrasive cleaning compounds or steel wool.

6. After all the particulate matter has been removed, wipe down the interior of the cooking compartment, particularly below the normal operating level, with a vinegar solution. When done daily this will prevent the buildup of calcium and other mineral deposits left over from the boiling of water, and prevent scale buildup in the steamer. Rinse the inside of steamer compartment and drain valve thoroughly with clean water.
7. Inspect the probe assembly and clean it with a vegetable brush or similar non-abrasive cleaning means. If detergent has been used to clean the inside of the steamer, be sure and thoroughly rinse off the probe assembly with a vinegar solution. If detergent residue is not completely rinsed from the probe assembly the film residue can prevent the water level control from properly operating.
8. Clean the door assembly.
  - Remove the door gasket assembly (see Figure 2-10).
  - Note the keyhole slots on the door and the retaining pins on the gasket assembly. Grasp the gasket assembly at the sides and lift up and towards you to remove the assembly.
  - Clean all surfaces of the gasket assembly, as well as the inside of the door, by wiping with a damp cloth.
  - Rotate the liner assembly 180° and replace the gasket assembly by sliding the retaining pins into the keyhole slots. Either long edge of the gasket assembly can be positioned at the top. Periodic rotating of the door assembly will increase the door gasket life.



**Figure 2-10 Door Gasket Assembly**

9. Replace the cleaned KleanShield™ (See Chapter 2, Section A, Part 3), slide racks and fan guard.

 <b>WARNING</b>
Never operate a SteamChef™ 3 Steamer without the KleanShield™ properly installed in the bottom of the water reservoir or the fan guard installed over the fan.

10. Wipe the exterior with a damp cloth only. NEVER HOSE DOWN THE STEAMER. Electrical components inside the unit will not function correctly if wet or damp and may cause a shock hazard.
11. After cleaning, leave the steamer door open until the next steamer operation. This prevents compartment odor buildup and increases gasket life.

## **CHAPTER 3. PREVENTATIVE MAINTENANCE AND TROUBLESHOOTING**

### **A. MAINTENANCE**

Maintenance on the steamer must be performed on a regular basis to keep the unit running properly and efficiently. By following the simple maintenance instructions in this chapter and cleaning the equipment regularly as outlined in Chapter 2, Part D, problems with the steamer will be kept to a minimum. As with any preventative maintenance schedule, the frequency of steamer maintenance may need to be increased, depending on equipment usage and water quality. If problems do occur, refer to the Troubleshooting Guide in this chapter. For more information on product and services, contact your sales representative.

## 1. Maintenance Records

Make a file solely for maintenance and repair records. Keep a written record of daily, weekly, monthly, and yearly maintenance. These records will protect warranty coverage, help personnel to know when to perform various maintenance procedures, help keep the SteamChef™ 3 cooking properly and assist service personnel.

## 2. Daily Maintenance

### a. Checking and Changing the Water

When using the SteamChef™ 3 frequently check the water, especially if cooking with perforated pans. Although, most food drippings will be caught by the KleanShield™, the water may still become soiled from occasional spilled food that falls over the edge of pans or when removing and loading food into the steamer. Replace the water as outlined below whenever the water becomes cloudy or heavily contaminated with food particles. At the very least **CHANGE THE WATER IN THE STEAMCHEF™ 3 AT LEAST EVERY DAY IN ORDER TO MAINTAIN FOOD QUALITY AND KEEP THE STEAMER SANITARY.**

**Note:** It may be necessary to change the water several times a shift, especially if cooking strong flavored foods or with perforated pans.

- 1) Open the steamer door and allow steamer to cool.
- 2) Turn the ON/OFF lever counter-clockwise (up) so that the white reference marker on the lever is pointing directly left to turn the power OFF, deenergize all controls and drain the steamer.
- 3) Remove the KleanShield™. Remove any food particles and rinse the KleanShield™ with clean water.



- 4) Remove any spilled food from inside compartment and rinse any residue from the drain valve and the KleanShield™ drain.
- 5) Replace the KleanShield™ (see Chapter 2, Section A, Part 3).
- 6) Turn ON power to the steamer by turning the drain valve lever clockwise (down) to close the drain (see Figure 2-7). The power ON indicator will light. The steamer will automatically begin filling with water to the normal operating level.
- 7) Close the door. The 'SureCook™' indicator will light (timer models only), and the steamer will begin to automatically heat the water supply to the standby cooking temperature.
- 8) When the 'SureCook™' indicator turns OFF (timer models only) the Steamer is now ready to begin cooking.

### b. Cleaning the Steamer

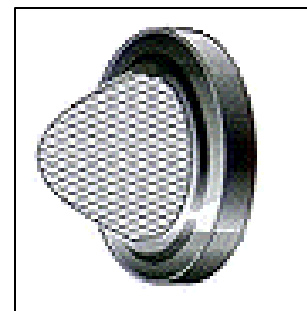
Clean interior and exterior of the steamer according to the shutdown instructions in Chapter 2, Part D at least once per day if not at the end of each shift.

## 3. Yearly Maintenance – Cleaning the Water Strainers

Clean the water line strainers at least once a year as follows:

NOTE: When the steamer is first installed, check the strainer more frequently to find out how often it must be cleaned.

1. Turn OFF power to the steamer at the main electrical disconnect switch/breaker.
2. Close the valves in the steamer water supply lines.
3. Unscrew the hoses from the inlet fittings located on the rear of the steamer.
4. Remove the filter washers (Figure 3-1) from the outlet of the hoses and wash them with clean water.
5. Check the filter washer for wear and replace it if necessary.
6. Put the filter washers into each of the water inlets and reconnect the hoses to the back of the steamer. Note if treated water is used to supply water to the reservoir, make sure that it is connected to the left inlet at the rear of the steamer (See Figure 4-1), which provides feed water for the production of steam.
7. Open water supply valve(s) and check for water leaks.
8. Turn back on power to the steamer at the main electrical shutoff/breaker.



**Figure 3-1 Filter Washer Assembly**

## B. OPERATORS TROUBLESHOOTING GUIDE

The Troubleshooting guide includes a list of symptoms that may be encountered during routine operation and maintenance. The first column on the left (PROBLEM) describes these symptoms. The second column lists the possible causes for the problem in column one. The third column lists possible remedies for the problems and causes in columns one and two. The causes and remedies are listed in the order they should be checked, with the least costly and easiest to repair listed first. The third column also refers to notes that are grouped at the end of the troubleshooting guide. Refer to these notes when instructed to do so.

**Table 3-1 Trouble Shooting Guide**

<b>PROBLEM</b>	<b>POSSIBLE CAUSE</b>	<b>REMEDY/REFERENCE</b>
Power indicator light does not turn ON when ON/OFF lever is in the ON position.	Power turned OFF at main external power switch.	Turn ON power at main power switch.
	ON/OFF lever not fully turned to the ON position.	Turn lever to the full ON position.
	Inoperative controls or indicator.	See note #1
Power ON and steamer does not fill	Water supply to steamer shut OFF	Open water supply lines.
	Water line strainer and/or external filter system clogged.	Clean water supply strainer and/or filter system.
	Water sensor is grounded.	Rinse water sensor assembly thoroughly with vinegar solution.
	Inoperative controls or solenoids.	See notes #1 and #5
Control panel power indicator light ON, and steamer does not come up to cooking temperature or produce steam.	Door interlock switch not engaged.	Close door completely.
	Water supply to steamer shut OFF	Open water supply lines.
	Water line strainer and/or external filter system clogged.	Clean water supply strainer and/or filter system.
	Unit is in the timed mode and timer is not set (Dial timer control models only)	Change to manual mode or set the timer.
	Hi-limit switch has tripped.	Reset steamer according to instructions found in Chapter 2, Section A, Part 7. If condition repeats itself see note #1.
	Inoperative controls.	See note #1.

(Continued on next page)

**Table 3-1 Trouble Shooting Guide (Continued)**

<b>PROBLEM</b>	<b>POSSIBLE CAUSE</b>	<b>REMEDY/REFERENCE</b>
Steam and/or water draining around the compartment door.  <b>See Warning under note #7.</b>	Either the vent, the drain to the vent or the KleanShield™ opening is clogged or covered.	Clear vent or collector opening and/or clean the drain with USDA approved drain cleaner and flush drain thoroughly with fresh water as applicable. If condition persists see note #1.
	Door gasket or door parts worn.	See note #1.
	Hot water instead of cold water connected to the condenser water line	See note #2 and #3.
	External drain or vent not properly installed, should be free air vented and pitched down.	See notes #2 and #3.
	Steamer not level.	See note #2.
	Condenser not operative	See note #1.
Abnormal amount of steam coming from drain or vent.	Hot water instead of cold water connected to the condenser water line	See note #2 and #3.
	External vent is not installed in drain tee	See notes #2 and #3.
	Inoperative controls	See note #1
Abnormal amount of steam coming from drain during draining of steamer	ON/OFF lever/switch is not turned fully to the OFF position	Turn lever/switch to the fully OFF position to activate drain cooling feature.
	Water line strainer and/or external filter system clogged.	Clean water supply strainer and/or filter system.
	Hot water instead of cold water connected to reservoir fill line	See note #2 and #3.
	Inoperative controls.	See note #1.
Compartment bottom dirty with food drippings.	KleanShield™ not installed	Install KleanShield™ to catch food drippings
	Juices and/or food leaking from pans during loading and unloading of steamer.	Put a solid pan under perforated pans to catch drippings, or put less food in pan.
Food takes too long to cook.  <b>To verify the steamers proper operation see note #8.</b>	Pans too close to the bottom of cabinet.	Put pans in racks near top of cabinet.
	Compartment overloaded with too much food.	Put less food into pan. Use fewer pans.
	Suggested cooking times are usually listed for cooking at sea level.	Extend cooking times for altitudes above 2500 feet.
	Convection fan inoperative	See note #1.
	Voltage too low for unit.	See note #4.
Control panel Power indicator is on, buzzer is buzzing continuously and Reset indicator is lit.	High limit has been tripped.	Reset steamer according to instructions found in Chapter 2, Section A, Part 7. If problem repeats itself, see Note #1.
	Inoperative controls.	See Note #1.
Steam coming out of the exhaust.	A small amount of steam may issue from the exhaust whenever the unit is in the cooking mode.	This is normal operation of the steamer <b>NO</b> action is necessary.
	Water line strainer and/or external filter system clogged.	Clean water supply strainer and/or filter system.
	Hot water instead of cold water connected to reservoir fill line	See note #2 and #3.
	Inoperative controls.	See note #1.

## TROUBLESHOOTING NOTES

1. A qualified service technician must repair problem or do the appropriate maintenance
2. Proper installation of the steamer is the responsibility of the owner or installer. A qualified installer or technician should be contacted to correct the installation
3. Repairs to external plumbing should be done by a Licensed Plumber.
4. Repairs to external wiring should be done by a Licensed Electrician.
5. Should the automatic fill system fail for any reason the steamer will eventually stop heating when the water level drops below the minimum operating level. Should this happen, the unit can continue to be operated by manually filling the water reservoir with about a gallon of water approximately every half-hour, until service can be scheduled.
6. For more information on products and services, contact your nearest Authorized Sales Representative. Call factory for a preventative maintenance program and water treatment systems: USA: (800) 338-2204, Canada: (800) 427-6668.
7. Whenever opening door, especially when water or steam is leaking around gasket heed the warning below.

### **WARNING**

When checking inside the steamer always open the door slowly and stand to the side and back away from the steamer. Water leaking from the door gasket can be a sign of a blocked drain. If the drain is blocked, hot water can accumulate inside the compartment and spill out when the door is opened.

8. To evaluate whether a SteamChef™ steamer is producing normal cooking performance, conduct the Egg Test as follows (NOTE: this test is not valid for pressure steamers). A properly operating steamer will produce cooked eggs as follows.

Turn on the steamer, and set the selector switch to the manual mode (or for ON/OFF models set the selector to the ON position) so that steam is being produced. When wisps of steam has begun to exit the steam vent, preheat the steamer by leaving it ON for ten minutes. After the compartment is preheated follow the instructions as listed below.

- Place a fresh egg on a perforated steamtable pan in the middle of the cavity.
- Close the door and set the timer as directed by the size chart below

Size	SteamChef™
Medium	12 minutes
Large	14 minutes
Extra Large	14 minutes

- When time is complete, carefully remove the egg and place in a container with cold water running over it.
- Let cool under cold running water for 5 minutes.
- After cooling, crack egg shell and peel.


The result will be a perfectly hard boiled egg.

# CHAPTER 4. INSTALLATION INSTRUCTIONS

## A. GENERAL

This equipment should only be installed by qualified, professional plumbers, pipe fitters and electricians.


- The installation of this steamer must conform with the Basic Plumbing Code of the Building Officials and Code Administrators International, Inc. (BOCA) as applicable, The National Electrical Code, ANSI/NFPA No. 70-(latest edition) or the Canadian Electrical Code, CSA C22.2 as applicable, the Food Service Sanitation Manual of the Food and Drug Administration (FDA) and all applicable state and local codes and regulations.
- The installation instructions must be read in their entirety before starting the installation of this steamer.

 <b>WARNING</b>
<p><b>Improper installation, adjustment, alteration, service or maintenance can cause property damage, injury or death. The Installation, Operating and Maintenance instructions should be read thoroughly before installing or servicing this equipment</b></p> <p>DO NOT INSTALL a SteamChef™ 3 steamer suspected of damage.</p> <p>Install the SteamChef™ 3 steamer according to the policies and procedures outlined in this manual.</p>

- In order to properly install this steamer, the following requirements must be considered when selecting a location.
  - a. A suitable electrical supply must be available matching the power requirements found on the rating plate.
  - b. The location must have sufficient space to meet the clearance requirements of the steamer as outlined in Chapter 4, Section B, Part 1, "Locating the Steamer".
  - c. A potable cold water supply meeting the requirements outlined in Chapter 4, Section B, Part 10 "Water Supply Requirements and Installation" must be available
  - d. A suitable drain must be available within 12 ft. of the steamer.

## B. INSTALLATION OF THE STEAMCHEF<sup>™</sup> 3

After selecting the steamer's operating location the steamer can be positioned, and installed. After Startup and Checkout, the SteamChef™ 3 steamer will provide years of reliable operation.

 <b>CAUTION</b>
<p>Malfunctions and equipment damage may result from improper mounting.</p> <p>The steamer <b>MUST BE LEVEL BOTH FRONT TO BACK AND SIDE TO SIDE</b> in all mounting arrangements.</p> <p>Catastrophic damage can result from shifting the SteamChef™ 3 more than 10 out of level while power is turned on at the main external power supply switch.</p>

## 1. Locating the Steamer

### Location and Clearance Requirements of the Steamer

- (1) Do not locate the steamer directly over a floor drain.
- (2) Observe the following criteria when selecting an operating location for the SteamChef™ 3 steamer.
  - Maintain a 3-inch operating clearance at the sides of the unit, and at least a 4-inch clearance at the back.
  - A 12 in clearance is recommended on the right side for servicing the steamer.
  - Approximately 24 inches of clearance is recommended in front of the unit for opening the door and standard pan clearance.

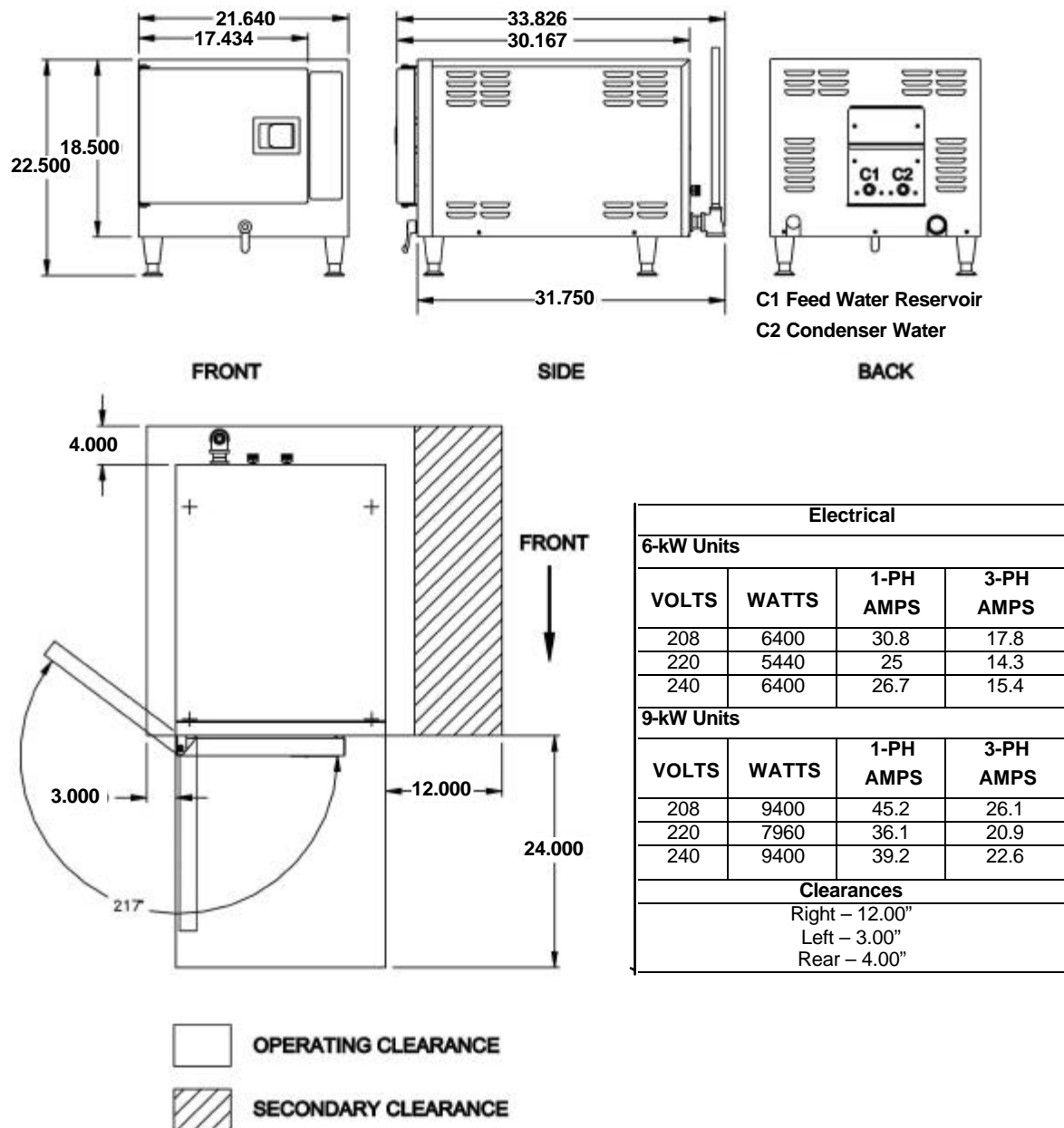


Figure 4-1 SteamChef™ 3 Dimensions and Clearances

- (3) The steamer is typically installed with four adjustable mounting legs, as shown in the dimension drawing. The steamer must be level both front to back and side to side. Select an operating surface that is level enough to allow leveling the unit without extreme adjustment of the legs or shimming of surface mounts.
- (4) The counter area selected must be capable of supporting an operating weight of approximately 260 pounds to include the weight of water and food.
- (5) Do not block the vents on the side or rear of the unit. Do not store articles on top of the unit.
- (6) If a satisfactory counter location is not available, consider using a Model ES222834 Equipment Stand. This stand, illustrated in Figure 4-2, is designed to support the SteamChef™ 3, and meets all necessary support and safety criteria. A stacking stand, Model No. ES222824S, is also available. The Model ES222834S stacking stand allows the installation of two SteamChef™ 3 Steamers one on top of the other. See Section 1, Part B and C for the installation instructions for installing SteamChef™ 3 steamers on Cleveland Range Stands.



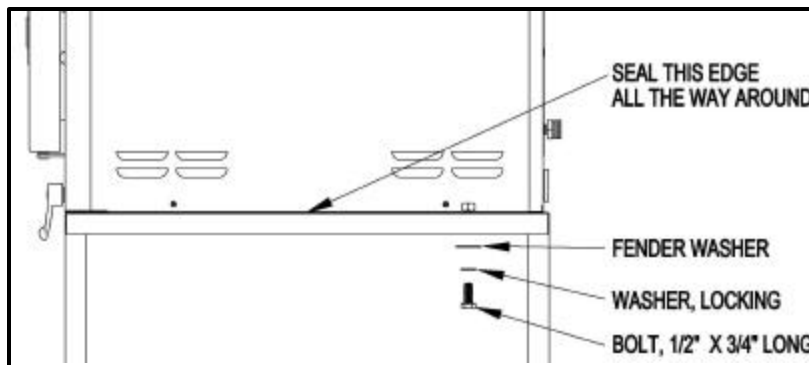
**Figure 4-2 ES222834 Equipment Stand**

**2. Installation Using Cleveland Range Stand Model No. ES222834.**

- a. Move the stand (Figure 4-2) to the selected location. We recommend that the feet with round mounting pads be at the rear of the steamer.

<b>WARNING</b>
<p>INJURY AND EQUIPMENT DAMAGE could result from improper lifting. A Model Number 22CET3 weighs approximately 250 pounds. Use enough workers with experience lifting heavy equipment to place the steamer on the supporting surface.</p>

- b. Set the unit on the stand with the front of the unit flush with the front edge of the stand. Mount the unit to the stand from below using the 1/2 x 0.750 lg. bolts and fender washers provided with the Stand Kit (Figure 4-3, on following page) installed into the rear leg mounts of the steamer.
- c. Seal the unit to the stand around the edge as shown in Figure 4-3, with a suitable RTV sealant. **Note:** Be careful not to seal the side panels to the steamer.



**Figure 4-3 Mounting the Steamer on the Equipment Stand**

- d. Complete the installation of the steamer in accordance with the remaining instructions of this manual. Once the unit has been leveled using the adjustable feet provided on the stand, it is recommended that the unit be secured to the floor using the two Anchorable legs.

### 3. Installation of Cleveland Range SteamChef® 3 Steamers on the Model No. ES222824S Stacking Stand

The Cleveland Range Model ES222824S Stacking Stand includes the stand and all the necessary hardware to connect the two units plumbing into a common drain outlet and a common set of water inlets.

#### a. Beginning Installation of the Cleveland Range Model No. ES222824S Stacking Stand

- 1). Move the stacking stand base (Item 1, Figure 4-4) to the selected location. We recommend that the feet with round mounting pads be at the rear of the steamer.

#### b. Mount the lower unit to the stand base

- 2). Remove the side panels of the lower steamer and set it into place on the Stacking Stand base (Item 1, Figure 4-4).
- 3). Mount the lower unit to the stand from below using the 1/2 x 0.750 lg. bolts and the fender and locking washers provided installed into both rear leg mounts as shown (See Figure 4-4).
- 4). Seal any gaps between the stand and the steamer with suitable RTV sealant (not provided).

#### c. Install the stand spacer onto the lower unit

- 5). Set the studded spacers (Figure 4-5 Item 2) on top of the lower unit lengthwise with the nearer stud on the end towards the front of the steamer. Next set the spacer retainer (Figure 4-5 Item 1) over the studded spacer and the steamer (see Figures 4-4 and 4-5). The studs from the spacer will go through the corresponding openings in the retainer, and the lower edges of the retainer will extend over the top of the lower unit (See Figures 4-4 and 4-5).
- 6). Seal between the lower steamer and the spacer retainer with suitable RTV sealant (not provided).

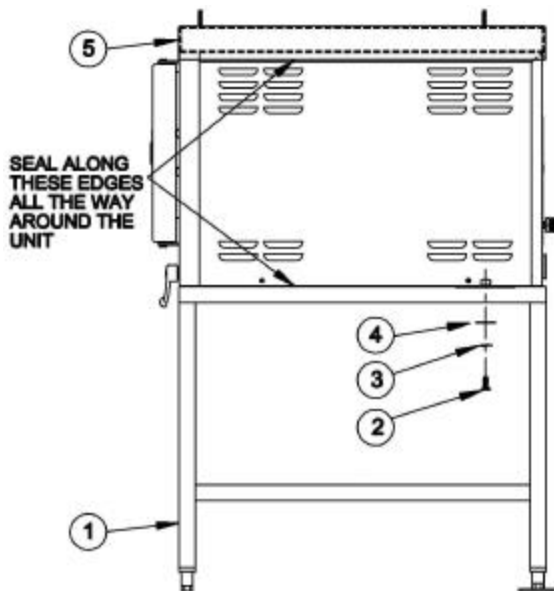


Figure 4-4 Installing Lower Unit

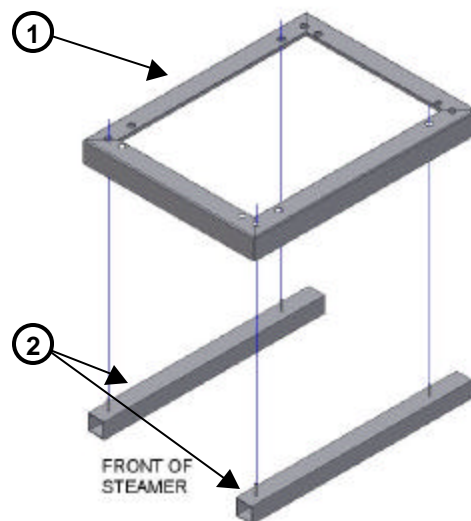
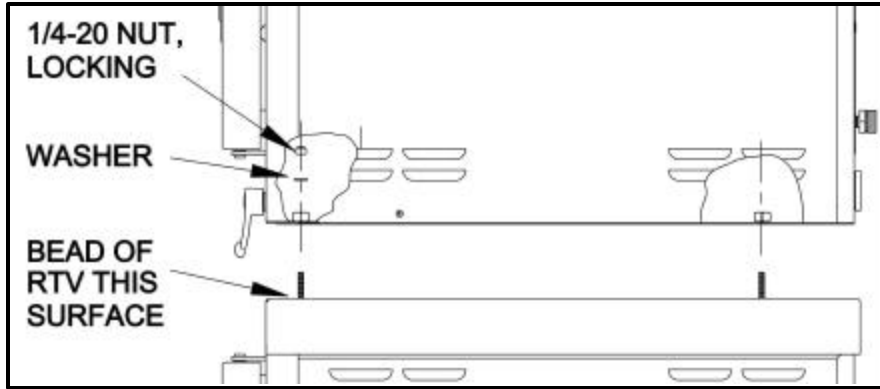


Figure 4-5 Positioning the Studded Spacer

**d. Mounting the Upper Unit**

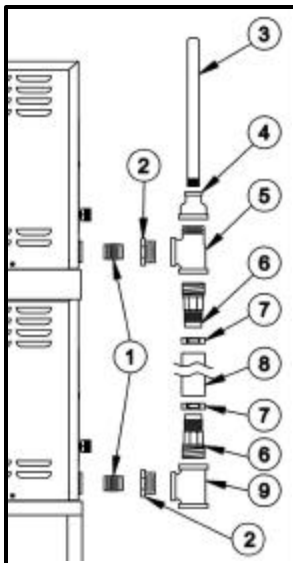
- 7). Before setting the upper steamer into place over the spacer studs, place a bead of RTV around the edge of the entire spacer outline.
- 8). Remove the side panels from the upper unit and set it onto the spacer. The ¼-20 studs of the spacer should go through the ½” welded nuts normally used to secure the legs to the steamer.
- 9). Secure the upper unit to the stand at the front pair of studs using the ¼-20 Lock Nut and Washer provided (Figure 4-6).



**Figure 4-6 Mounting the upper unit**

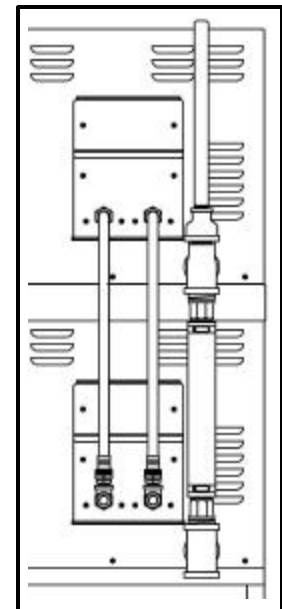
**e. Installing the Drain Between the Two Steamers**

- 10). Assemble the drain fittings onto the steamers as shown in the schematic. Be sure to use a suitable pipe dope compound or Teflon tape at all threaded connections.
- 11). Lay the Drain hose (Figure 4-7 Item 8) out between the upper and lower hose fittings as it may be necessary to shorten the length slightly depending on the fit-up of pipe



Drain Parts			
Item No.	Part No.	Description	Qty
1*	14369	Nipple, 1” NPT, Close, Black Iron	2
2	02573	Bushing, Hex, 1 ½” NPT x 1” NPT	2
3	111008	Nipple, ¾” NPT x 14”, Toe	1
4	03616	Coupling, Reducing, 1 ½” NPT x ¾” NPT, Black Iron	1
5	20220	Tee, 1 ½” NPT, Male Run, Black Iron	1
6	110985	Fitting, 1 ½” Hose x 1 ½” NPT(M), Plated	2
7	102018	Clamp, Hose, Worm Drive	2
8	110984 1300	Hose, Black EPDM, 1 ½” ID x 13” long	1
9	20221	Tee, 1 ½” NPT, Black Iron	1

\* Supplied with the steamer not part of the kit



**Figure 4-7 Drain Assembly**

- 12). Put the Worm drive clamps over the hose and then install the hose between the two hose fittings.

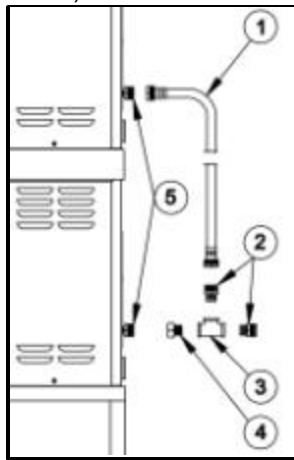
NOTE: It may be easier to install the hose over the upper fitting first, and then loosen the lower fitting (by turning the lower drain plumbing assembly counter clockwise) to get the hose started over the lower hose fitting. Once started in this manner the hose will then slide over the hose fitting when the pipe assembly is turned back into its final position as shown in Figure 4-7.

13). Tighten the hose onto the hose fittings with the worm drive clamps.

**f. Installing the Plumbing**

14). Assemble the water trains for the condenser and feed water as shown in Figure 4-8. Be sure and use pipe dope at all threaded pipe connections and that a suitable washer or washer strainer is located at each National Hose threaded (GHT, garden hose thread) connection (DO NOT USE PIPE DOPE ON NATIONAL HOSE THREAD CONNECTIONS).

NOTE: The national hose thread (also known as garden hose thread) inlets of the SteamChef™ 3 steamers water connections, come supplied with strainer washers (not shown). These washers must be used at the steamer water inlet connections.



Drain Parts			
Item No.	Part No.	Description	Qty
1	110998	Hose Assembly, GHT(F) x GHT(F), 2 Ft. Long	2
2	110977	Fitting, 1/2" NPT (M) x 3/4" GHT (F), Brass	2
3	20229	Tee, 1/2" NPT, Brass	2
4	110986	Fitting, 1/2" NPT (M) x 3/4" GHT(M), Brass	4
5*	110987	Strainer, Filter Washer, Garden Hose Inlet	4

\* These parts are installed in the steamer, and should be left in the units as part of the final installation.

**Figure 4-8 Plumbing Assembly**

**g. Complete the Installation of the Steamer**

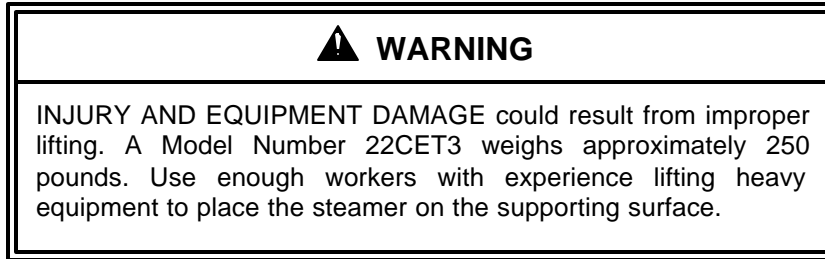
15). Complete the installation of the steamer in accordance with the remaining instructions of this manual. Once the unit has been leveled using the adjustable feet provided on the stand, it is recommended that the unit be secured to the floor using the two Anchorable legs.

**4. Installing the Legs**

The legs on the SteamChef™ 3 are used for installing the steamer, except when it is installed with any of the Cleveland Range stands.

- (1) Check that the feet are fully retracted into the legs. Do not over tighten. The feet should easily screw in and out using fingers only.
- (2) Place the SteamChef™ 3 on its left side.
- (3) Screw the four legs into the weldnut mounting holes. All four legs must be installed for proper mounting of the SteamChef™ 3.
- (4) Place the steamer upright on the four legs

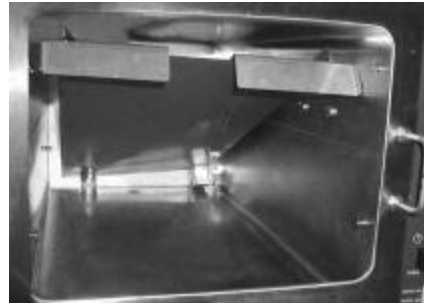
## 5. Positioning and Leveling the Steamer



Move the steamer into position. Using a level, adjust the adjustable legs of the unit or the Cleveland Range stand as applicable until the unit is level.

## 6. Installation of the KleanShield™

- a. Never operate a SteamChef™ Steamer without a properly installed KleanShield™.
- b. Note the KleanShield™ must be installed before the side pan racks.
- c. Place the KleanShield™ into the steamer with pipe extension towards the back and facing down. Set the KleanShield™ in place over the corresponding pipe extending out of the bottom of the steamer reservoir. See Figure 4-9.
- d. The KleanShield™ is installed properly when the pipe from the KleanShield™ is fitted into the corresponding pipe in the bottom of the steamer and its legs are flush against the bottom of the steamer. See Figure 2-6 in Chapter 2 showing an installed KleanShield™.



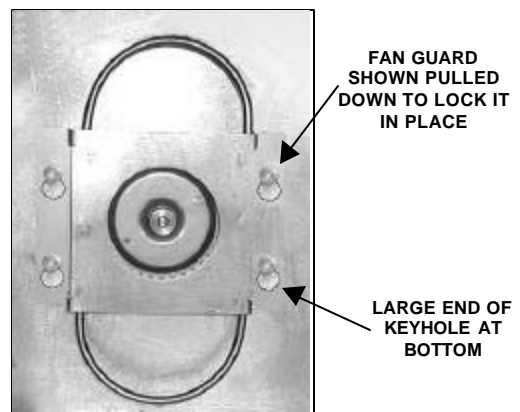
**Figure 4-9 KleanShield™ Installation**

## 7. Installing the Fan Guard

To properly install the Fan Guard, hold the fan guard so that the large ends of the keyholes are towards the bottom of the steamer. Place all four openings over the mounts located on the rear wall of the steamer and pull it down so that the narrow ends of the slots are pulled tight over the mounts. See Figure 4-10.

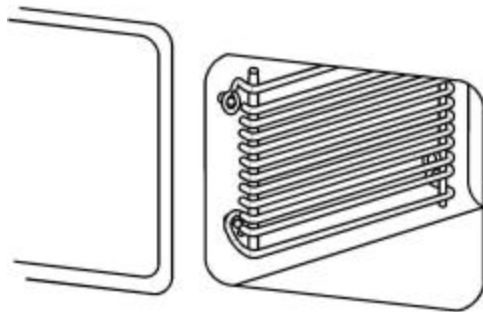
## 8. Install Slide Racks and Rear Vent

- a. Refer to Figure 4-11. Each rack has four loops: two at the top and two at the bottom. Hold the slide rack so the ends of the hanger loops are towards the cavity wall, as shown in the figure.
- b. Slide one rack into the compartment with loops toward one side.
- c. Hook the loops over the top and bottom pins.
- d. Repeat steps a. through c. for the other racks.
- e. Using pipe sealant (not provided), install the drain tee into the rear of the steamer using the close nipple provided, as shown in Figure 4-12. (Note: For Steamers installed on a Cleveland Range Model ES222824S Stacking Stand refer to the instructions found in Section B, Part 3 of this Chapter, for proper vent installation).

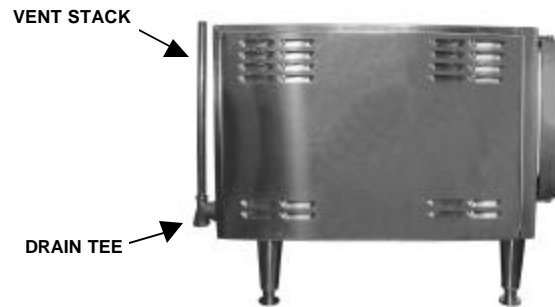


**Figure 4-10 Fan Guard Shown in Installed Position**

- f. Install the threaded end of the Vent stack into the ½” outlet of the drain tee using pipe sealant.
- g. The unit is now ready for connection to a drain, see Chapter 4, Section B, Part 9.



**Figure 4-11 Slide Rack Installation**



**Figure 4-12 Steam Vent Assembly Installation**

### 9. Install the Free Air Vented Drain Lines

Furnishing and installing the drain line is the responsibility of the owner and/or installer. Figure 4-13 illustrates a drain layout recommended by Cleveland Range.

**⚠ WARNING**

DEATH, INJURY, AND EQUIPMENT DAMAGE could result from improper installation of the drain outlet lines.

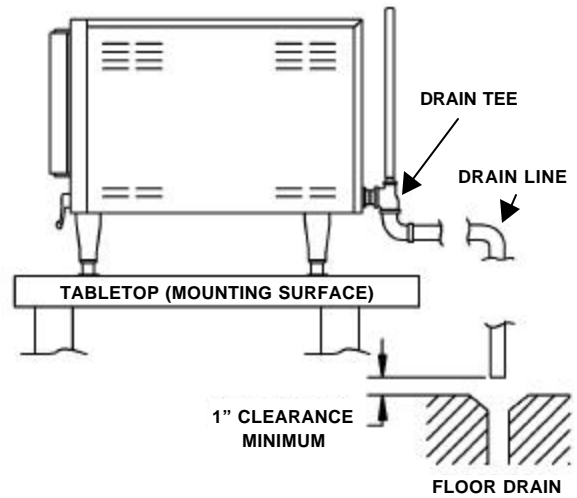
Improper installation of these lines could void the SteamChef™ 3 Steamers warranty. The following restrictions are critical to the safety of personnel and equipment, and must not be violated under any circumstances.

- Do not connect the drain line into PVC or any drain material that cannot sustain 180° F.
- Do not connect drains from any other equipment to the drain line of the SteamChef™ 3 Steamer.
- Do not connect the drain outlet extension line directly to a floor drain or sewer line.

The drain line must be free air vented, have gravity flow from the steamer, and terminate outside the perimeter of the unit.

- a. The drain lines must be installed in compliance with the Basic Plumbing Code of the Building Officials and Code Administrators International, Inc. (BOCA), and the Food Service Sanitation Manual of the Food and Drug Administration (FDA) and any state, provincial or local codes.
- b. Do not install the steamer directly over a drain. Steam rising up out of the floor drain will adversely affect operation, cooling air ventilation and may damage electrical components. (See Figure 4-13)
- c. The total length of pipe and number of bend fittings required to reach the open drain determines the pipe size used to extend the drain line to an open drain.
  - If the drain outlet extension requires 6 feet or less of pipe, and no more than two elbows are required, 1-inch (or larger) pipe and fittings are acceptable.
  - If the drain outlet extension requires 6 to 12 feet of pipe, or requires three or more elbows, or is installed on a Cleveland Range Model ES222824S stacked stand, 2 -inch (or larger) pipe and fittings are required.
- d. The drain line must have a gravity flow from the steamer drain outlet to the floor drain. Do not install a trap in the drain line.

- e. Free air venting requires a minimum of 1 inch of clearance between the end of the drain line and the top of the floor drain.
- f. Do not connect the steamer drain directly to drains or plumbing of any other equipment. (Except when using a Cleveland Range designed application such as is used with the Model ES222824S Stacking Stand)
- g. Refer to Figure 4-13 and connect the drain to the steamer as described below:
  - The steamer is supplied with a 1-inch pipe connection at the bottom of the drain tee.
  - When assembling the pipes and fittings of the drain outlet extension, apply a hardening type pipe sealant to the threads, and thread them together FINGER TIGHT ONLY. DO NOT USE A WRENCH.



**Figure 4-13 Typical Drain Connection SteamChef™ 3**

## 10. Water Supply Requirements and Installation

### a. Water Supply Requirements

#### 1). Water Quality

Unlike most steam utilizing equipment, the water quality can vary significantly without any undue loss of performance of a SteamChef™ steamer. Even exceedingly hard, mineral laden water will not affect the operation of a SteamChef™ 3 as long as it is cleaned with vinegar daily as outlined in Chapter 2, Section D.

#### 2). Water Supply System

A potable water supply system must be available providing a minimum dynamic pressure of 35 psi (2.4 kg/cm<sup>2</sup>) and a maximum static pressure of 60 psi (4.1 kg/cm<sup>2</sup>).

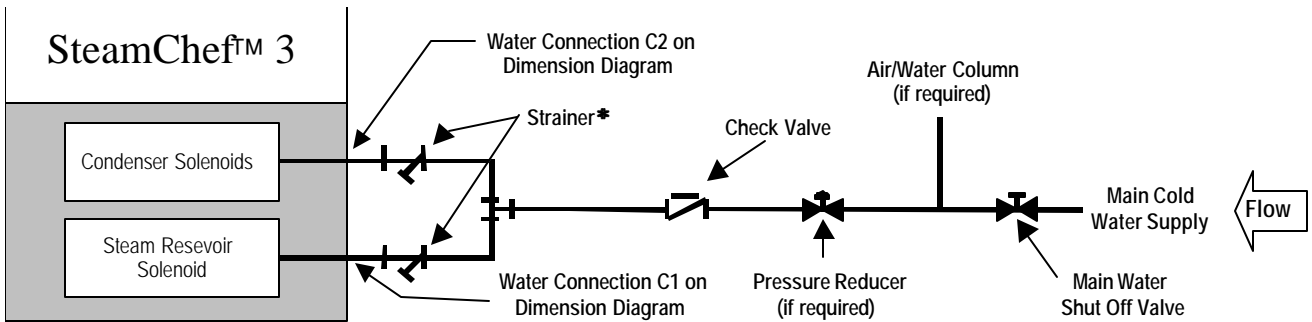
### b. Install Water Supply Lines

The installer/owner is responsible for the correct water connection of the unit. When connecting the water supply lines observe the following instructions and all national and local codes and regulations:

- 1). Never connect the unit to HOT WATER. The condenser system of the steamer will not work properly if it is connected to HOT or WARM water.
- 2). The water supply should have a minimum flow pressure of 35-psi (2.4 kg/cm<sup>2</sup>) and a maximum static pressure of 60-psi (4.1 kg/cm<sup>2</sup>). If the static pressure is above 60 psi, a pressure regulator must be used set at approximately 50 psi. Pressure above 60 psi can damage the solenoid valves.
- 3). The SteamChef™ steamers are supplied with two connection points for incoming water, one feeds the condensers and the second supplies feed water to the reservoir. Although, the SteamChef™ is very tolerant of water conditions a customer may want to use conditioned water to supply the feed water to the reservoir. In the case of using a separate conditioned water supply, use the layout shown in Figure 4-15.
- 4). Pay attention to the following requirements and recommendations when connecting the steamer to the water supply:
  - a) Cleveland Range recommends the plumbing layout illustrated in either Figure 4-14, for installations using a single water supply or Figure 4-15 if a separate conditioned water supply is being used for the steam reservoir feed. Note: If using a single water feed to the

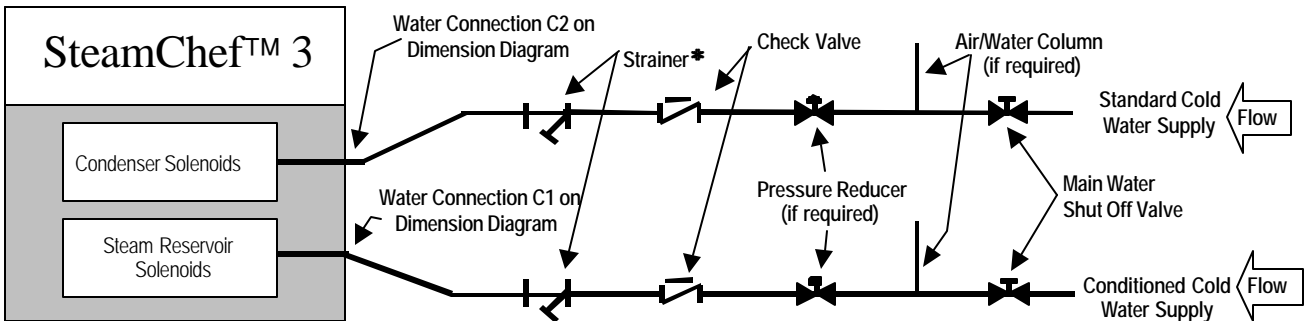
system the supply piping to the tee fitting should be of at least the next largest size of pipe to the connection provided at the steamer.

- b) The steamer has two 3/4-inch NHT fittings (Standard Garden Hose fitting) for the water connections to the water reservoir and to the condenser. These fittings are detailed as **C1** and **C2** in Figure 4-1. **NOTE:** The hose connector used must be NSF or FDA rated for food grade service.
- c) Install a manual water valve between the main cold water supply line(s) and the steamer supply lines.
- d) The National Sanitation Foundation (NSF) requires installation of a check-valve in all supply lines in accordance with and as required by local plumbing codes.
- e) The water supply line(s) should be designed so that the unit can be moved for service.



**Figure 4-14 Cleveland Range Single Water Supply Arrangement**

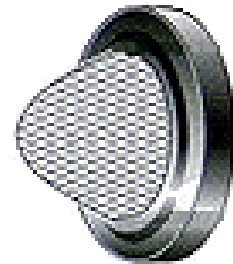
(\*The strainers for this unit are preinstalled in the water inlet)



**Figure 4-15 Cleveland Range Separate Water Supply Arrangement when Using Separate Conditioned Feed Water Supply**

(\*The strainers for this unit are preinstalled in the water inlet)

- f) A Filter Washer (dirt filter) is supplied installed in each of the water inlets of this steamer (See Figure 4-16), Cleveland Range part number 110987.
- g) Construct all supply lines up to the point of installing the strainer. Flush the water supply lines before connecting the strainer.
- h) Apply pipe dope or Teflon tape to any threaded pipe connections. **DO NOT USE SEALANT ON ANY NATIONAL HOSE THREADED CONNECTION.**



**Figure 4-16 Filter Washer Assembly**

### c. Testing Water Supply Lines

- (1) Check all connections for proper tightness. Remove the side panel to inspect water connections inside the steamer.
- (2) Open the water supply valves.
- (3) Check all lines and connections for leakage, both inside and outside the steamer.
- (4) If Startup and Checkout will be performed next, leave the right side panel off; otherwise, replace the side panel and secure it to the unit.

## 11. Install Electric Power Lines

The electrical supply must match the power requirements specified on the steamers rating plate and be made in accordance with the following requirements:

- a. The steamer must be grounded and have the electrical power lines installed in accordance with local codes and/or the National Electric Code, ANSI/NFPA No. 70-LATEST EDITION (USA) or the Canadian Electrical Code, CSA Standard C22.1 (Canada).
- b. The wiring diagram is located on the back of the control-side removal side panel.
- c. A main disconnect switch should be installed near the unit as shown in Figure 4-17. See Table 4-1 for electrical wire size.
- d. A separate fuse or breaker sized to meet the line amps required by the steamer (see Table 4-1) should be installed either as part of the main external power switch or in a separate fuse box. Throughout the remainder of this manual the fused disconnect switch is referred to as the main external power switch.
- e. There should be a sufficient length of flexible conduit or Power Cord (if local codes permit it) between the steamer and the wall so the unit can be serviced. Mechanically secure the flexible conduit or power cord to the electrical access hole found at the rear of the steamer (Figure 4-18).

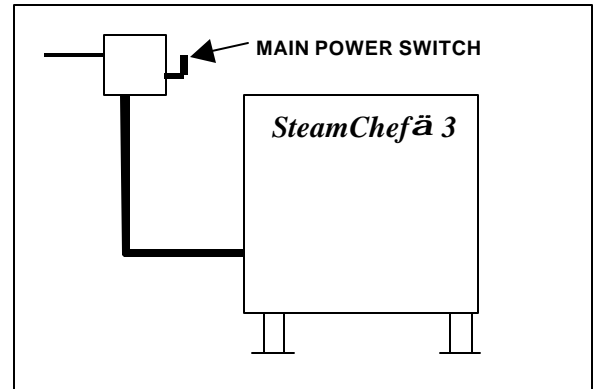
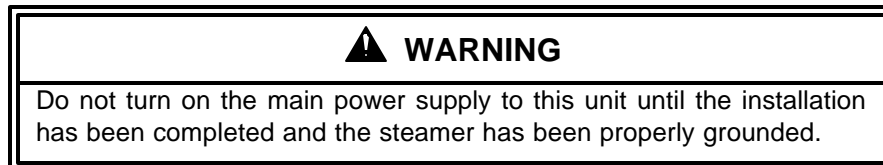


Figure 4-17, Recommended Electrical



- f. Refer to the wiring diagrams and Figure 4-19, and connect the wires to the terminal block and ground connector accordingly.
- g. The steamer must be electrically grounded by the installer.

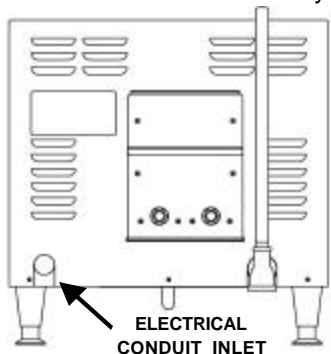


Figure 4-18, Customer Electrical Connection Inlet

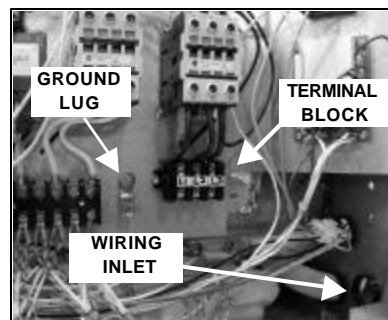


Figure 4-19, Electrical Connections

**Table 4-1 Minimum Wire Requirements**

**3-Phase Units**

WATTS	VOLTS	PHASE	WIRES	CYCLE HERTZ	AMPS	SUPPLY CONNECTION WIRE SIZE (COPPER)	HEATER RATED VOLTAGE
6400	208	3	3	60	17.8	12	208
5440	220	3	3	60	14.3	14 (12 recommended)	240
6400	240	3	3	60	15.4	14 (12 recommended)	240
9400	208	3	3	60	26.1	10	208
7960	220	3	3	60	20.9	10	240
9400	240	3	3	60	22.6	10	240

**1-Phase Units**

WATTS	VOLTS	PHASE	WIRES	CYCLE HERTZ	AMPS	SUPPLY CONNECTION WIRE SIZE (COPPER)*	HEATER RATED VOLTAGE
6400	208	1	2	60	30.8	8	208
5440	220	1	2	60	25	10	240
6400	240	1	2	60	26.7	10	240
9400	208	1	2	60	45.2	6	208

\* For supply connection use only copper wire suitable for at least 75° C (167° F).

**C. STARTUP AND CHECKOUT**

The Startup and Checkout procedure prepares a recently installed or repaired steamer for operation. The procedures check proper installation and electrical connection of the steamer, and verify basic steamer operation.

**1. Installation Checkout**

Use the Installation Checklist Table 4-2, to check the overall installation.

**Table 4-2. Installation Check List**

TASK	REFERENCE	COMPLETED
Preparation	Page No.	
Verify electric power requirements	30	_____
Check operating location clearances	20	_____
Verify Field Assembly of Unit	24-26	_____
Verify Field Assembly of Stand (if applicable)	21-24	_____
Installation		
Verify Steamer is Level	25	_____
Check drain line connection	26	_____
Check water supply connection	27	_____
Test water supply lines	29	_____
Check electrical line connection	29	_____
Perform Startup and checkout	31	_____

**Notes on installation:**

## 2. Operating Test and Final Checkout Procedure

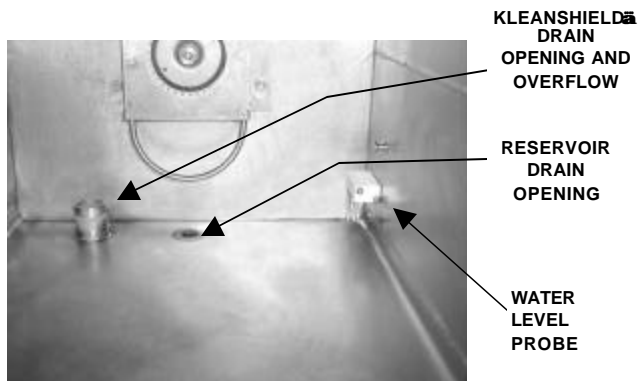
The standard Cleveland Range SteamChef™ 3 is equipped with either a manual dial timer control panel or an ON/OFF Control panel.

The ON/OFF works exactly like the manual operation of the timer model except that a selector switch is used to turn the cooking function from the standby heat mode (OFF) to the cooking mode (ON).

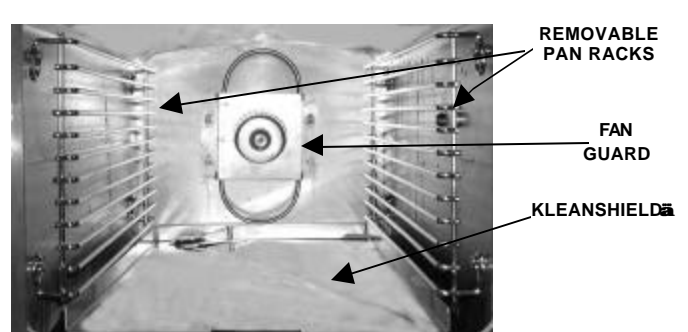
This procedure will evaluate the function of all the major operating controls of the SteamChef™ 3. Read through all steps of this procedure before starting. Complete the Startup Procedure before starting the actual operating tests. **This procedure should be performed only by a service technician or installer.**

### a. Startup Procedure

- (1) Check that the ON/OFF Lever is in the OFF position. There should be no water in the steamer.
- (2) Open the steamer door. Remove the slide racks and KleanShield™ and check that neither the KleanShield™ nor reservoir drains are blocked (See Figure 4-20). Replace the KleanShield™ and pan racks™ (see Figure 4-9 and 4-10 on Page 25 for installation instructions) and check for proper installation of the KleanShield™, fan guard, slide racks, and door gasket assembly (See Figure 4-21).



**Figure 4-20 Inspecting Compartment drains**



**Figure 4-21 Inspecting Compartment Interior Accessories**

- (3) Refer to electrical layout, Figure 4-17, and Table 4-1. Be sure the main power switch is in the OFF position. Verify installation of the proper size fuses or breakers.
- (4) Set the ON/OFF Lever/Switch to the OFF position and open the steamer door.
- (5) Remove the right side access cover.

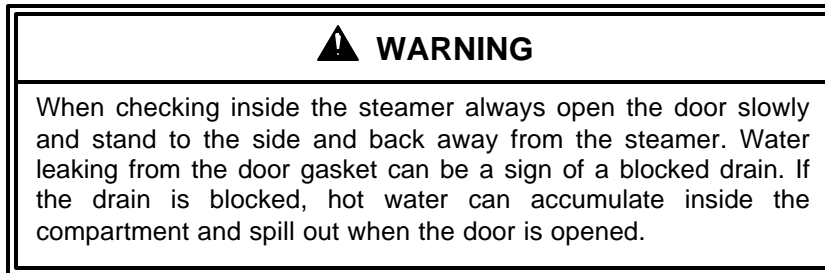
<b>⚠ WARNING</b>
Death, severe electrical shock or equipment damage can result from touching any component inside unit when main power switch is in the on position. Use extreme caution during testing with the access cover removed.

- (6) Check the internal wiring and make sure there are no loose or disconnected wires. Verify that the supply wiring is of adequate size and that the unit is properly grounded. Correct any deficiencies.

**b. Drain Rinse Inspection (continue from Startup Procedure)**

- (7) Turn ON the water supply to the steamer.
- (8) Turn ON electric power to the steamer at the main external power switch. The steamer will immediately start a 3-minute drain rinse cycle. During the drain rinse cycle, the fill and drain valves are fully open while the steam generator drains are flushed with fresh water.
- (9) Stop the drain rinse cycle before it is complete by setting the ON/OFF lever/switch to the ON position. This energizes the operating control circuits, the green Power ON and amber "SureCook" (Timer Models only) indicators on the control panel light, drain rinse stops, and the steam reservoir begins to fill with water.
- (10) Restart the drain rinse cycle by setting the ON/OFF switches to the OFF position. During the automatic drain rinse cycle, make the following checks.
  - Check for plumbing leaks.
  - Look at the one-inch vent gap between the steamer drainpipe and the floor drain. A steady stream of water should be draining from the steamer.
  - **NOTE:** The ON/OFF lever must be turned fully to the OFF position to START the proper drain rinse sequence.
  - After about 3 minutes, the cycle is complete. Check the gap at the steam drain; there should be no more water flow at this point.

**c. Operating Tests and Final Checkout Procedure (Continue from drain rinse Inspection) (Sequence of Operation)**



- (11) At the start of this test the controls should be set as follows:
  - The main power switch is ON.
  - The ON/OFF lever/switch is OFF (The green and amber [timer models only] indicators on the control panels are not lit).
  - The TIMED/MANUAL switch is in the TIMED position. (or for ON/OFF models the ON/OFF compartment selector switch is in the OFF position)
- (12) Set the compartment timer to zero, by turning the dial counter clockwise until it points to the 0 mark.
- (13) Set the ON/OFF lever/switch to the ON position. As the steam reservoir fills with water, check the following functions.
  - a). The green Power ON and amber "SureCook" indicator lights turn ON. The fill valve opens and water begins to fill the compartment reservoir.
  - b). Immediately, water should begin appearing in the bottom of the compartment reservoir. Close the compartment door to close the door interlock circuit. As the water level in the compartment reservoir rises;
    - ◆ Check that no water flows from the drain opening.
    - ◆ Check for plumbing leaks in the control compartment.

- (14) When the water in the steam generator reaches a safe operating level (which is the level of the lower probe), heating elements and the convection fan will come ON and the unit will begin warming up to the standby heat temperature. Open the door; the heating elements and convection fan will turn OFF.
- a) Water continues to fill the generator and the water level in the reservoir continues to rise.
  - b) The water in the reservoir stops rising, when water reaches the upper probe.
    - ◆ If the water level continues to rise above the tip of the higher probe, see the troubleshooting guide on page 16. If the problem persists have a qualified service representative check the probe circuit.
- (15) Close the compartment door to close the door interlock circuit.
- a) The heating elements and the convection fan will come back ON and the unit will begin warming up to the standby heat temperature.
  - b) The unit will continue to heat up until the standby heating temperature is reached.
    - ◆ When the standby heat temperature is reached, the “SureCook” indicator lights and the convection fan will turn OFF, and the heating elements will be de-energized.
  - c) If the unit is left in this mode the heating elements and convection fan will intermittently cycle ON and OFF to maintain the standby heating temperature.
- (16) Set the TIMED/MANUAL switch to MANUAL (or for ON/OFF Models set the selector switch to ON), the steaming cycle starts. Check the following functions.
- The heating elements, the condenser water and convection fan will turn ON and the water will begin to heat to steam. After a few seconds, a stream of water flows from the drainpipe.
  - After a few more minutes the compartment will reach cooking temperature. The heating elements, condenser water and convection fan will continue to be ON for as long as the unit remains in manual (or ON for ON/OFF Control Models).
  - With the unit in manual cooking mode (or for ON/OFF Models, when the unit is ON) the unit will continue to operate at the cooking temperature for up to 60 minutes, or it is set to the timed cooking mode. After several minutes of steaming, check for steam leaks around the door gasket.
- NOTE:** That after 60 minutes of uninterrupted operation in the manual mode or for an ON/OFF unit left “ON” (continued operation without opening the doors, or switching the unit to the timed mode), the unit will automatically drop back down to the standby heating temperature. This is done to save energy and water, and maximize equipment operating life. To return the unit to the cooking temperature, simply open and close the compartment door.
- (17) As the unit continues to steam in Manual Cooking Mode, test the no-water/low water safety circuit.
- a) Close the manual water supply valves to the steamer.
  - b) When the water level drops below the lower water safety cutoff point (the lower probe). The heating system (including the condenser water and convection fan) will automatically shutoff, and the production of steam will cease.
  - c) Re-open the manual water supply valve to the steamer. The steamer’s controls automatically refill the steam reservoir with water to the safety level and the steamer will resume steaming.
- (18) When the TIMED/MANUAL switch is set to TIMED (and the timer is zeroed), the steam generating cycle stops. Press the TIMED end of the TIMED/MANUAL switch.

- The heating elements and the condenser and convection fan will stop. The buzzer will sound for 3 seconds.
  - Steam will stop being produced and the compartment will return to the Standby Heating Mode.
- (19) Open the cooking compartment door to vent the steam and allow the compartment to cool slightly. After 2 or 3 minutes, close the door and continue testing.
- (20) With the TIMED/MANUAL switch set to TIMED, set the timer for 10 minutes.
- (21) As soon as the dial is set, the steam generating cycle starts. This is the same sequence observed in steps 5 through 7, except:
- The timer controls the cycle.
  - The elapsed time to produce steam is shorter because the water in the steam generator and the cooking compartment were preheated during step 15.
  - The timer automatically returns the unit to the standby heating temperature (as described in step 9) after counting down to zero.
- (22) After the timed operation has been started, observe the following steam generating functions.
- a) The heating elements and convection fan come on immediately. Depending on temperature in the compartment the “SureCook” indicator will also come on. The “SureCook” indicator remains ON until the compartment reaches the minimum cooking/standby heat temperature, at which time the timer begins counting down to zero, and the “SureCook” indicator light turns OFF and the condenser will come ON. Shortly a small stream of water flows from the drainpipe.
  - b) As the unit generates steam, the water level fluctuates and a clicking sound is heard as the solenoid opens and closes the fill valve. The level in the reservoir rises and falls between the upper and lower fill limit as the fill valve operates.
  - c) Check for steam leaks around the door.  
When the timer counts down to zero, the heating elements, the condenser flow and convection blower turn OFF, and the buzzer sounds for 3 seconds.
- a) After about 30 seconds steam stops being produced.
- (23) Turn the steamer OFF by turning the ON/OFF lever/switch counterclockwise to the OFF position. The green Power ON indicator light turns OFF immediately, and the automatic drain rinse cycle starts. DO NOT turn OFF the power at the main power switch until the drain rinse is complete. The cycle takes about 3 minutes.
- (24) When the drain rinse is complete, turn the steamer OFF at the main power switch.
- (25) Install the side panels and secure them in place with the original fasteners. After completing the Startup and drain rinse Inspection procedure, and the Operating Test procedure; the steamer is ready for service. Refer to Chapters 1 and for complete operating and safety instructions.

## CHAPTER 5 STEAM COOKING GUIDE

### A. INTRODUCTION:

Steam Cooking is an excellent way to prepare countless foods. With large and small quantities you will find cooking to be efficient, economical, fast and convenient. Food can never burn-pans will never boil over-there is no heavy lifting of water in pots-no scouring of containers-no waiting for boiling to start. Steam cooking is efficient, economical and convenient. From the Steamer to the steam table, it saves money in labor/time, and, of course, the quality and consistency remains the same.

### **Seafood:**

Steaming is an excellent method of cooking a variety of seafood. From the freezer directly into the steamer gives you, the operator, portion control on expensive seafood products. Steamed fish is tender, succulent, flaky and table ready in a matter of minutes.

### **Vegetables:**

Steam cooking vegetables, either fresh or frozen, enhances color, improves flavor, and helps retain vitamins when recommended timer settings are followed. Steaming fresh vegetables on perforated pans gives best results.

### **Meat:**

Steam provides an even, intense and penetrating heat, which, because of its nature, cooks meat with minimal shrinkage. The meat is tender, moist and flavorful. Stews, pot roasts, ham and corned beef are excellent steam cooked. Steam tenderizes stewing fowl. It produces excellent meat for sandwiches and salads, both moist and savory and is easily sliced.

### **Desserts:**

Many kinds of cornstarch pudding and custard desserts are prepared by steaming. Fruit desserts such as steamed "Baked Apples" are another suggestion. Core the apple and arrange on a shallow pan. Fill the cored apple with cinnamon and sugar, then steam. If desired, browning under the broiler may finish the apples. Applesauce is another steam application, as are stewed pears or peaches. Dried fruit, properly marinated, turn out beautifully.

### **Additional Ideas:**

There are many applications for steam cooking besides vegetables and seafood:

- Eggs can be soft cooked, coddled, hard cooked, poached, scrambled, and made into custard or pudding. 25 dozen eggs can be hard cooked in 12 minutes using three 12" x 20" x 2½" perforated pans in one compartment of the steamer.
- Momentary steam blanching of fruits, including citrus and pineapple, simplifies skin removal.
- Dumplings, steamed breads, muffins, hot cereal, pasta, noodle and rice can be prepared or reheated in the steamer.
- Beef and other meat, cooked by steaming, is moist, tender and flavorful. The meat drippings from the catch pan can be used to make gravy soups or clear stock, as a salt free broth.
- Turkey, chicken and other poultry are tender, juicy when steamed then combined into a casserole, added to BBQ sauce, or browned under the broiler. Chicken pieces can be breaded, steamed, then finished in the deep fryer. It is crisp, delicious, and juicy.
- Hot Dogs, sausages and other variety meats remain plump and juicy when steamed.
- Entrees such as lasagna, macaroni and cheese, or beef stew can be prepared from scratch. Frozen institutional packs can be reheated in the steamer. It is not necessary to cover.

**B. SIZING UP PAN CAPACITY:**

**1. Serving Sizes – How Much? How Many?**

How to estimate portion size and number of servings from a standard steam table pan.

- A 12" x 20" x 2½" (65mm-1/1GN) solid pan will hold 1-7/8 gallons or 240 fluid ounces (30 liters or 7200ml).

**Table 7-1 Serving Size**

240 Fluid Ounces Produces (7200ml)

<u>Portion Size</u>	<u>Number of Servings</u>	<u>Type of Product</u>
10 oz (300ml)	24	Stew, Casserole, Lasagna
8 oz (240ml)	30	Soup, Bisque
6 oz (180ml)	40	Soup, Bisque
4 oz (120ml)	60	Mashed Potatoes
2 oz (60ml)	120	Sauce
1 oz (30ml)	240	

- Number of servings of cooked vegetables from one 12" x 20" x 2½" perforated pan. (65mm-1/1GN)

Frozen Vegetables Yields:

10.0 lbs. (4.5kgs)	Approx. 50-3 oz (90ml) servings
7.5 lbs. (3.4kgs)	Approx. 35-3 oz (90ml) servings
5.0 lbs.	Approx. 25-3 oz (90ml) servings

**2. Reference Charts for Typical Pan Capacities**

Pan Capacity stated in terms of usable fluid ounces per straight side pan. When filled to overflowing, estimate a higher figure per pan.

Width x Length (inches)	12 x 20	12 x 13	12 x 10	12 x 6	10 x 6	6 x 6
Steam Table Pan Size	Full Size	2/3 Size	½ Size	1/3 Size	¼ Size	1/6 Size
<u>Pan Depth</u>	<u>Fluid Ounces</u>					
2 ½"	240	175	125	75	55	35
4"	420	294	208	125	95	55
6"	625	435	314	186	140	82

Pan Capacity stated in quarts per straight-sided pan. Capacity as stated is to overflowing.

<u>Pan Depth</u>	<u>Fluid Quarts</u>					
2 ½"	7 7/8	5 ¾	4 1/8	2 5/8	1 7/8	11/4
4"	13 ½	9 ½	6 ¾	4 1/8	3 1/8	1 7/8
6"	20	14	10 1/8	6 1/8	4 5/8	2¾

**Can Size and Volume**

<u>Can Size</u>	<u>Cup</u>	<u>Net Weight or Fluid Oz.</u>
No 2 ½	3 ½	27-29 oz
No 3	5 ¾	51 fluid oz.
No 10	12-13	6 ½ - 7 lb., 5 oz.

**C. CONVECTION STEAMER – SUGGESTED TIMER SETTING GUIDELINES FOR  
TIMER CONTROLS WITH THE COMPENSATING THERMOSTAT (see Note)**

Timer settings are approximate due to the differences in food quality, age, shape and the degree of doneness desired. It is not necessary to add water. Perforated pans are recommended. Starred items (\*) must be cooked in solid pans. Items marked with two stars (\*\*) require handling in two steps. First steam for approximately ½ the time shown, remove from steamer, separate thawed portion, or stir, and return to steamer for the time remaining. The compensating feature of the timer allows the cooking compartment to reach temperature before the preset time starts to count down. **Note:** Times may need to be increased slightly when using external timers to track cooking times.

VEGETABLES:	Fresh	Frozen		Fresh	Frozen
Artichoke	12		Tomatoes, whole, sliced*	1	
Asparagus, spears	4	6	Turnips, whole	20-25	
Beans, green, 2" cut	6	5	Zucchini, sliced	2-4	2-4
French cut	4	5**	<u>SEAFOODS:</u> Steam all seafood on a perforated		
Whole	6	4	pan with catch pan		
Broccoli, spears	3	2-3	Clams in shell	3-5	
Flowerets	2-3	1-2	Cod fillets, 5 oz.	3	4
Chopped		6-8	Portions		
Brussels sprouts	4-5	4	Crab legs, king		4-6
Cabbage,	2		Snow crab		2-4
Whole to remove			Crab, live, 4 oz.		
Leaves for cabbage rolls			3/4 - 1 lb.	12	
Carrots-baby whole	10	6	Halibut, 6-8 oz.	4-6	6-8
Sliced,	7-8	3	Portions		
Diced		2	Lobster, whole, 1 lb.	7-9	
Cauliflower,			Lobster tails, 8 oz.		8-10
Flowerets	4-5	3-4	Defrosted, butterflied		4-6
Whole	10		Mussels in shell	2	
Celery, Cut 1½"	3		Oysters in shell	2-4	
Diced	2	1	Red snapper, 8 oz.	4-5	
Minced	1		4-5		
Corn, yellow, whole		2	Salmon steak, 8 oz.	6	7
On cob,	6	12**	Shrimp, 10 ct. per lb. IQF	3	4-6
Cobbettes	6	12**	5lb. Block, peeled &		
Eggplant, sliced,	1		Deveined 30 ct.		6-8
Mixed Vegetables		3-4	5lb. Block, green, (nested pan)		6-8
Mushrooms,			26-30 ct.		10**
Whole 1½"	3		<u>EGGS (Medium Sized):</u>		
Sliced	1		Hard cooked for egg		
Onions, diced, sliced	2-3	1	Salad, potato salad	10-12	
Whole	4	2	Soft cooked	3	
Peas, green		2	Coddled	6	
Potatoes, whole 8 oz.	30-35		Poached in a cup	2-3	
Peeled, quartered,	12-19		Scrambled*	6-7**	
Fresh peeled, diced	8-10		<u>FRUITS:</u>		
Potatoes, sweet,	30-35		Blanch for peeling		
Whole			Fresh: Avocado	1	
Spinach leaf	2	21**	<i>(Continued)</i>		
Chopped		21**			
Squash, acorn halves					
Butternut, quartered					
Squash whipped*		20**			
Spaghetti squash, halves		15-18			

(continued from previous page)

FRUIT:	Fresh
Apple, cored	1
Grapefruit	1
Orange	1
Apricot	1
Pineapple, whole	2
Dried: add water to re-hydrate	
Apple	10
Apricot	10
Peach	10
Pear	10
Prune	10

**MEATS & POULTRY:**

Cook meats and poultry in nested pans, as juices can be used for gravy, sauces, beef stock and soups. The portion size, thickness, grades, should be considered when selecting a timer setting for doneness.

POULTRY:	Fresh	Frozen
Turkey, whole min./lb.	6-8 min./lb.	6-8
Chicken, 5-8 oz. Breaded piece halves, 1 1/4-1 1/2 lb. per half	18-20 min. 20-24 min.	

**PORK, SAUSAGE,**

HOT DOGS:	Fresh	Frozen
Pork, Chop, 4 count/lb.	10 min.	
Italian sausage, 4 oz.	10 min.	
Ribs, 3lb. and down	20-26 min.	
Hot-dogs, 8 count/lb.	2 min.	

BEEF:	Fresh	Frozen
Cubes, 1 1/2"	6-7 min./lb.	6 min./lb.
Ground chuck for chili	4 min./lb.	4-6 min./lb.
Pot-roast, choice	8-12 min./lb.	
Rump roast, choice		
Boned, rolled, tied	12 min./lb.	
Meat loaf, 4lb. Loaf	5 min./lb.	
Liver, baby beef, 8oz.	2-4 min./lb.	2-4 min./lb.
Corned beef, 6-8lb. cut, add 1/2" water		
Pan	20-23 min./lb.	

**STEAKS: :** Fresh Frozen

Using a 3/4" to 1" steak, the steaming time listed below produces a "rare" steak. A "well done" steak is first steamed to the "rare" stage, then broiled or grilled for 1 1/2 minutes on each side. This "well done" steak shrinks less, is more tender and juicy; and, when served, is the same size as the "rare" steak.

STEAKS: :	Fresh
Sirloin Patties	
Chopped 8 oz	4 min.
Ribeye, 8 oz.	4 min.
Top butt steak 6 oz.	4 min
8 oz.	6 min.
Filet Mignon, butterflied –	
4 oz.	3 min.
6 oz.	3-4 min.
8 oz.	4 min.
10 oz.	5 min.
16 oz.	8.min
(CHateaubriand)	
Strip steak - 10-oz.	5 min.
12 oz.	7 min.
T-bone 12 oz.	5 min.
16 oz.	8 min.
18 oz.	8 min.
22 oz.	10 min.

**PREPARED ENTREES:** Fresh Frozen

PREPARED ENTREES:	Fresh	Frozen
Full Size Pans		
Cabbage rolls, stuffed* Cover with tomato Sauce & serve	25 min.	20 min.
Casserole dishes*		
Beef Stew	20-25 min	25-30 min.
Stroganoff	20-25 min.	25-30 min.
Lasagna* fresh	20-25 min	25-30 min.
Reheat ea. serving 4"	6-8 min.	12 min.

**DEHYDRATED FOODS:**

Potatoes* 2 1/2" random sliced Plus 5 cups cold water /lb.	12 min.
---	---------

**RICE & BEANS:**

Rice, long grain 4 cups cold water/lb.	17 min.
Beans, pre-soaked overnight, 1 lb. Beans = 1 1/4 qt. Water	45 min.
Beans* unsoaked, 1 lb. Beans x 1 1/2 qt. water	2 1/2 Hours
Refried beans, 2-#10 cans	15-17 min.

**PASTA:**

Steam in nested pans. Place pasta on 2 1/2" perforated pan used as a liner in a solid 2 1/2" pan. Cover pasta with cold water.

Egg noodles, 1 1/2" wide	4-6 min. **
Lasagna noodles	10-12 min.**
Macaroni, shells, elbow	10-12 min.**
Rigatoni	10 min. **
Spaghetti, vermicelli	8 min.**
Spaghetti, regular	8 min.**

## **D. STEAMING TIPS - LOBSTER - CRAB - SHRIMP**

### **1. Live Lobster and Crabs**

- a. Live lobsters and crabs are steamed according to the time on the Suggested Timer Setting Guide.
- b. Steam them on a perforated pan with a catch pan (a solid pan) on a lower pan slide. Discard the juices and non-edible matter collected during steaming.

### **2. Lobster Tail 8 oz.**

- a. To serve in a shell, cut the frozen lobster tail in half, lengthwise. Place the cut side up on a perforated pan. Steam 5-6 minutes or until the meat turns opaque white. Season and garnish to serve.
- b. To serve a butterfly lobster tail, thaw tail, cut top shell length-wise all the way to the tail fins. Spread shells apart and pull meat out. Close empty shell and lay meat on top of shell. Steam according to Suggested Timer Setting Guide.

#### **For volume preparation:**

20 to 25. 6-8 oz. Lobster tails can be steamed on one 12 x 20 x 1 perforated pan.

### **3. King Crab Legs**

- a. Available as cooked and frozen. Steam just long enough to heat through.
- b. Served either whole or cut into 3 sections.
- c. Suggested Timer Settings 4 minutes  
12 lb of sectioned legs per 12 x 20 x 2 ½ perforated pan  
10 lb of whole legs per 12 x 20 x 2 ½ perforated pan

### **4. Shrimp**

- a. Shrimp are available as:
  - Green shrimp in frozen 5 lb. blocks
  - Peeled, deveined and ready to cook
  - Peeled, deveined and cooked
- b. Shrimp is a very delicate seafood. When over cooked it becomes very rubbery, therefore, it is better too slightly under cook the shrimp rather than over cook it. Refer to Suggested Timer Setting Guide for cooking shrimp for various sizes.

