

Parts Manual

Counter Type Gas Convection Steamer



Series: SteamCraft Model 21CGA5

1333 East 179th Street
Cleveland, Ohio 44110

Phone: (216) 481-4900
1-800-338-2204

Fax: (216) 481-3782
www.clevelandrange.com

 Cleveland

NOTES:

1. SEE INSTRUCTION DRAWING 104104 FOR LABEL LOCATIONS.
2. SEE INSTRUCTION DRAWING 1042573 FOR HOSE LOCATIONS.
3. REVISION SYMBOLS (A, B) ARE PLACED NEXT TO AFFECTED ITEM NO. IN BILL OF MATERIALS ONLY.
4. FOR STEAM CUT-OFF SWITCH OPTION SEE DRAWING 106596 FOR LOCATION OF HOLES IN FACEPLATE AND DRAWING 104335 FOR FACTORIAL WIRING INFO.

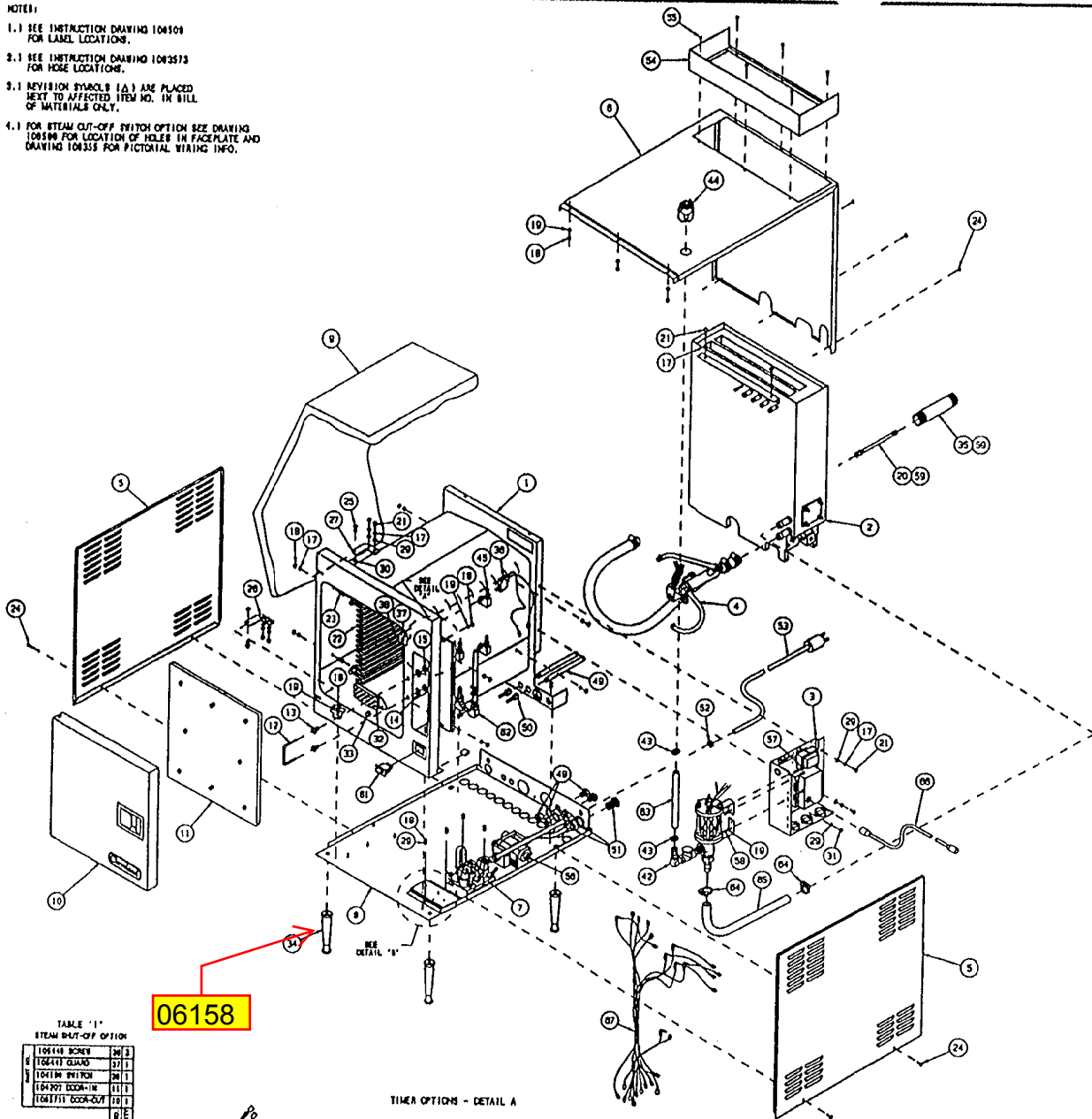

LET.	REVISIONS	DATE	BY
A	UPDATED PER VARIATION E.O. 9 PER ED NO-3732	11-03-94	PJD

300225

ITEM	QTY.	PART NO.	DESCRIPTION
97	-	108359	WIRE HARNESS, MECHANICAL, SC 3/3
-	-	108358	WIRE HARNESS, ELECTRONIC, SC 3/3
96	1	108359	HARNESS, WIRE, HIGH VOLTAGE
85	1	1080931400	HOSE, SILICONE 3/4 ID X 1/4 CO X 14
84	2	105847	CLAMP, PLASTIC 1-1/8 CO HOSE
83	1	1044880900	HOSE, SILICONE 1/2 ID X 3/4 CO X 9
82	1	1070591	BREATHER/ SPRAY NOZZLE ASSEMBLY
81	1	19994	SWITCH, ROCKER, SPST (CLEAN LIGHT)
80	2	234321	D-CLIP, SMALL
59	A/R	00934	SEALANT, RECTORSEAL
58	3	14892	NUT, HEX LOCK ELASTIC 10-24
57	3	19287	SCREW, PAN HEAD 10-24 X 1/2, S/S
56	-	1084041	VALVE ASSEMBLY, GAS, LP
55	6	19148	SCREW, HEX WASH HD, SLTD, #10 X 1/2
54	1	108444	HOOD, FLUE CLUSTER ASSM
53	1	108461	WIRE COORD ASM, 3 WIRE, 18 GA., 10SC
52	1	108579	BUSHING, HEYCO, STRAIN RELIEF
51	1	108157	FITTING, BULKHEAD 1/2"
50	2	108488	FITTING, HOSE 1/4 H X 1/4 FPT
49	2	108457	NIPPLE, 1/4 X 1 LG., BRASS
48	2	03841	FITTING, BULKHEAD 1/4"
47	-	1087801	HEAT STANDBY PLATE
-	-	108780	HEAT STANDBY / INT. BLOWDOWN PLATE
46	-	19972	THERMAL SWITCH
45	4	1082301	SPRAY NOZZLE ASSY, SC 3/1, 3/1 & 10
44	1	108428	PORT ASSEMBLY, DESCALER
43	1	105818	CLAMP, PLASTIC 3/4 O.D. HOSE
42	1	108521	FLOAT ASSEMBLY, DESCALER, SCS.1 GAS
41	-	23131	WASHER, FLAT, 5/16
40	-	23120	WASHER, FLAT, 3/8 X 7/8
39	-	104409	CLOSURE, THERMAL OPENING
38	-	105419	SCREW, TRUSS HD. 8-32 X .312, S/S
37	-	105412	GUARD, SWITCH PROTECTION
36	-	104198	SWITCH ASSY, OPT. STEAM SHUT-OFF
35	1	104485	NIPPLE, 1-1/2 X 8-1/2, BLACK
34	4	1014301	LEG, ADJUSTABLE, PLASTIC, 4"
33	1	14877	NUT, LOCK 1/4-20, S/S
32	1	89298	SCREEN, COMPARTMENT DRAIN
31	3	14885	NUT, HEX, ELASTIC LOCK, 1/4-20
30	2	104082	HINGE, SHIP, S/S
29	7	23118	WASHER, FLAT 1/4 X 5/8, S/S
28	8	14818	NUT, HEX 1/4-20, S/S
27	1	1040732	HINGE ASSY, WELD, TOP
26	1	1040731	HINGE ASSY, WELD, BOTTOM
25	2	104077	PIN, HINGE
24	7	104080	SCREW, TRUSS HD. SHIT. MET. #8 X 1/2
23	8	101303	PIN, RACK SUPPORT
22	2	21423	RACK, PAN SLIDE, 20"
21	8	19170	SCREW, HEX HEAD 1/4-20 X .625, S/S
20	1	104840	CONDENSER, ASSY, SPRAY
19	12	101855	WASHER, FLAT #10 S/S
18	13	14872	NUT, HEX LOCK, 10-32
17	17	23105	WASHER, LOCK, 1/4 KATLINK, S/S
-	-	108303	PANEL, CONTROL ASSY, ON/OFF
-	-	104181	PANEL, CONTROL ASSY, MECHANICAL
-	-	104238	PANEL, CONTROL ASSY, ELECTRONIC
15	2	14878	NUT, LOCK 1/2-13 PREVAILING TORQUE
14	2	23149	WASHER-NYLON, TYPE 8-8
13	2	14895	NUT, DOOR CATCH MOUNTING, S/S
12	1	104048	CATCH, DOOR
11	1	104207	DOOR ASSY., INNER
10	-	108351	DOOR ASSY, H.L. W/LOGO, W/ACTUATOR
-	-	108375	DOOR ASSY, H.L. W/LOGO
9	1	104193	INSULATION, BODY WRAP
8	1	108439	BASE, WELD ASSY, SCS.1 GAS
7	1	108522	VALVE ASSY, WATER INLET, SCS.1 GAS
6	1	108338	SHEETING, TOP/BACK, SCS.1 GAS
5	2	108340	SHEETING, SIDE, SCS.1 GAS
4	1	108524	VALVE ASSEMBLY, DRAIN, SCS.1 GAS
3	1	108523	COMPONENT PANEL ASSY, SCS.1 GAS
2	1	108407	GENERATOR ASSEMBLY, SCS.1 GAS
1	1	1041971	CAVITY, WELD ASSY, SCS.1 H.L.

DETAIL B

DETAIL A

DETAIL A

TABLE I

DETAIL A

TABLE I

TABLE '1'
STEAM SHUT-OFF OPTION

106148	SCREW	24	3
106417	GUARD	27	1
104181	SWITCH	26	1
104207	DOOR-IN	11	1
106171	DOOR-OUT	10	1

06158

TIMER OPTIONS - DETAIL A

DETAIL B - ITEM 47



104239
ELECTRONIC CONTROL

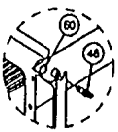

THERMAL SWITCH
ELECTRONIC OPTION



104181
MECHANICAL CONTROL

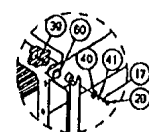

THERMAL SWITCH CLOSURE
(MECHANICAL & ON/OFF)

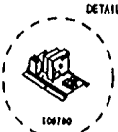

108780
INTERMITTENT BLOWDOWN AND HEAT STANDBY (OPTIONAL)

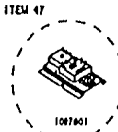

1087801
HEAT STANDBY (STANDARD)

THIS DESIGN DESCRIBES A PROPRIETARY ITEM AND IS THE PROPERTY OF CLEVELAND RANGE. THIS DRAWING IS NOT TO BE COPIED OR REPRODUCED WITHOUT THE APPROVAL OF CLEVELAND RANGE.

TOLERANCES (EXCEPT AS NOTED)		SCALE		DRAWN BY		APPROVED BY	
DECIMAL	± N/A	SCALE	N/A	DRAWN BY	DUTCHMAN	APPROVED BY	
ANGULAR	± N/A	TITLE					
		STEAMCRAFT ULTRA S, GAS, H.L. FINAL ASSEMBLY, ALL OPTIONS					
CK	DATE	08-02-93	DRAWING NO.	C - 106451		REV.	A

CLEVELAND RANGE INC.
1333 East 179th St. Cleveland, Ohio 44110-2574

NOTES:

1.1 SEE INDIVIDUAL ASSEMBLY DRAWINGS

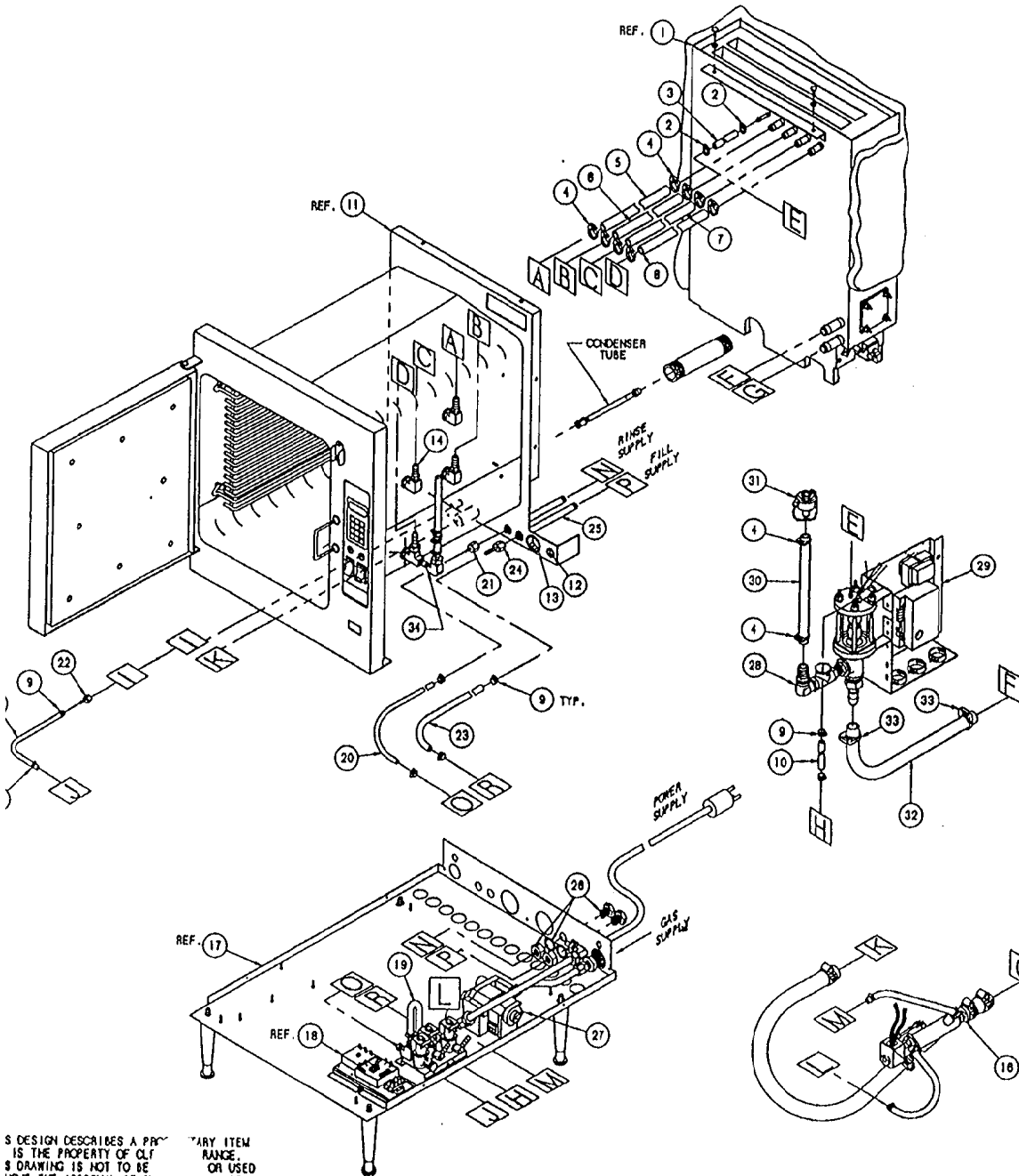

THIS DESIGN DESCRIBES A PRODUCT WHICH IS THE PROPERTY OF CLEVELAND RANGE. THIS DRAWING IS NOT TO BE REPRODUCED WITHOUT THE APPROVAL OF CLEVELAND RANGE.

LET.	REVISIONS	DATE	BY
A	P/41 108384 WAS 108524 AND ADDED P/45 104382, 1058500800, 108591, & 1088500400	08-03-93	PJD
B	REMOVED FLOW RESTRAINT ASSY AND ADDED 1/8" I.D. HOSES & FITTINGS AND 108522 REPLACED 104687 AND 108526 REPLACED 108219 AND 108524 REPLACED 108384 AND 108488 REPLACED 104381 PER E.O. KC-2192 R1	09-09-93	PJD
C	UPDATED PER VARIOUS E.O.'S - SEE E.O. KC-21732	11-07-94	PJD

34	1	1070591	BREATHER/SPRAY NOZZLE ASSEMBLY
33	2	105847	CLAMP, PLASTIC 1-1/8 HOSE
32	1	1080931400	HOSE, SILICONE 3/4 X 1.00 X 14 LG.
31	-	108428	PORT ASSY, DESCALER
30	1	1044880900	HOSE, SILICONE 1/2 X 3/4 X 9 LG.
29	-	108523	COMPONENT PANEL ASS'Y., SC 5.1, GAS
28	1	108521	FLOAT / DESCALER ASS'Y, SC 5.1, GAS
27	-	108404	GAS VALVE ASS'Y.
26	2	03841	COUPLING, BULKHEAD, 1/4 IPS, BRASS
25	2	108457	NIPPLE, 1/4 X 7 LG., BRASS
24	1	108488	FITTING, HOSE 1/4 H X 1/4 FPT, STR
23	1	1058501300	HOSE, NT-80, 1/4 X 1/2 X 13" LG.
22	1	108882	FITTING, HOSE 1/8 H X 1/8 FPT, STR
21	1	108885	FITTING, HOSE 1/8 H X 1/4 FPT, STR.
20	1	1088841500	HOSE, NT-80, 1/8 X 3/8 X 15" LG.
19	1	108522	VALVE ASS'Y, WATER INLET
18	-	1087601	HEAT STANDBY PLATE
17	-	108760	HEAT STANDBY / INT. BLOWDOWN PLATE
16	-	108439	BASE, WELD ASSEMBLY
15	1	108524	VALVE ASSEMBLY, DRAIN
14	3	1088842800	HOSE, NT-80, 1/8 X 3/8 X 28 LG.
13	1	1082301	SPRAY NOZZLE ASSEMBLY, STEAMCRAFT
12	1	102581	HEYCO BUSHING, INSULATOR, 7/8"
11	1	02800	HEYCO BUSHING SB-875-11, INSULATOR
10	-	1041971	CAVITY, WELD ASSEMBLY
9	8	1058501900	HOSE, NT-80, 1/4 X 1/2 X 19" LG.
8	1	108528	HOSE CLAMP, METAL 3/8 X 5/8 X 5/16
7	1	1044882700	HOSE, SILICONE, 1/2 X 3/4 X 27 LG.
6	1	1044882000	HOSE, SILICONE, 1/2 X 3/4 X 20 LG.
5	1	1044882200	HOSE, SILICONE, 1/2 X 3/4 X 22 LG.
4	10	1044881800	HOSE, SILICONE, 1/2 X 3/4 X 18 LG.
3	1	105848	HOSE CLAMP, NYLON, 3/4" OD HOSE
2	2	1043792200	HOSE, SILICONE, 1/4 X 1/2 X 22" LG.
1	-	104383	HOSE CLAMP, NYLON, 1/2" OD HOSE
1	-	108407	GENERATOR ASSEMBLY
ITEM	QTY.	PART NO.	DESCRIPTION

TOLERANCES (EXCEPT AS NOTED)			
CLEVELAND RANGE INC. 1333 East 179th St. Cleveland, Ohio 44110-2574			
DECIMAL ± N/A	SCALE 1/32"	DRAWN BY DUTCHMAN	APPROVED BY MLT
ANGULAR ± N/A	TITLE HOSE DETAIL STEAMCRAFT ULTRA 5, G.		
CK	DATE 08-17-93	DRAWING NO. C - 1063573	BY C

NOTES:
1. SEE WIRING DIAGRAM 104165 FOR WIRE CONNECTION POINTS.

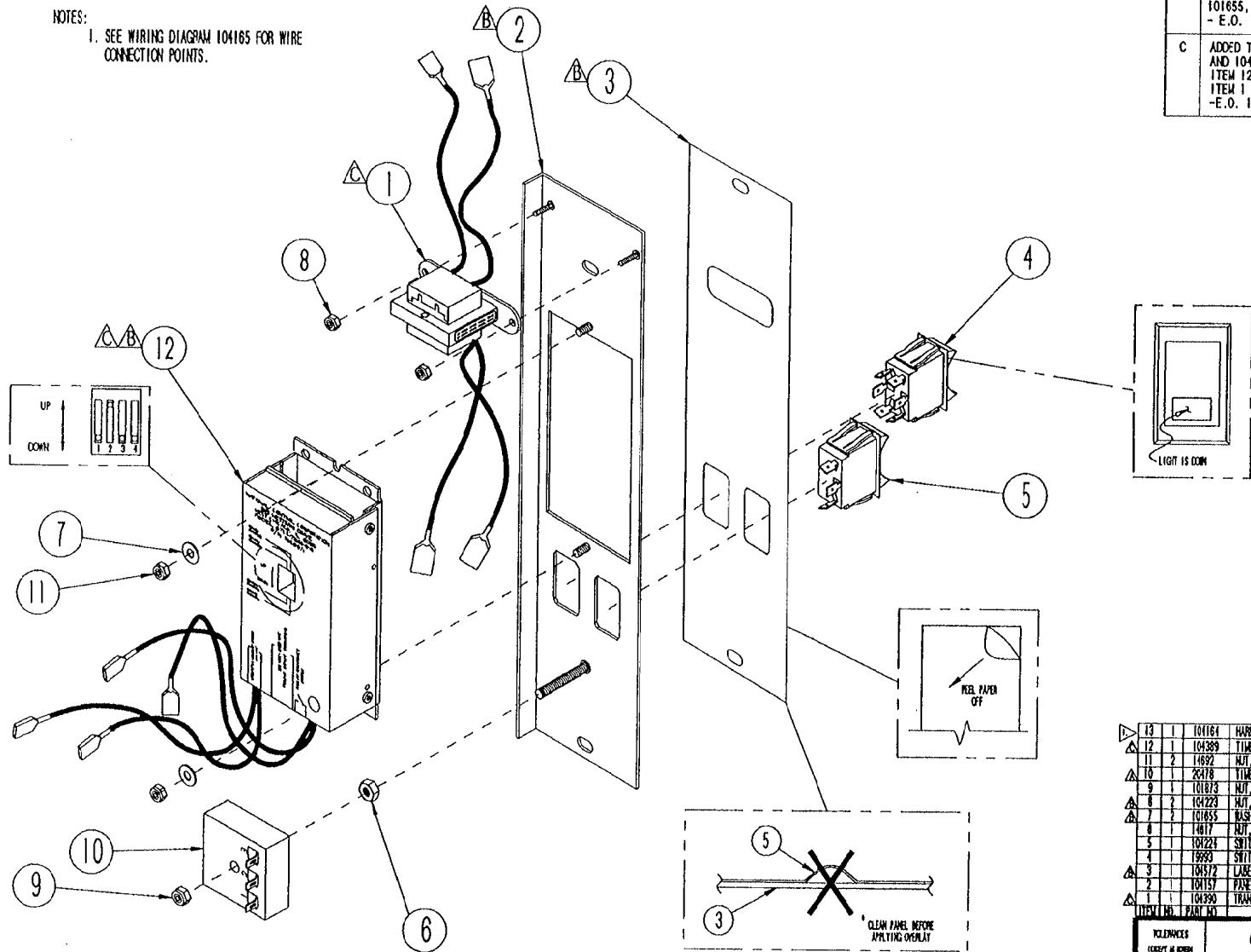

LET.	REVISIONS	DATE	BY
A	ITEM 12 WAS 20478, E.O. C-1781	9-18-90	RIOS
B	ITEM 3 WAS 104054 ITEMS 7 & 8 WERE QTY. OF 4 PICTORIAL CHANGES TO ITEMS 2, 3 & 12 REMOVED RELAY ITEMS - 03524, 03525, 101655, 104223, 1041290200 - E.O. 1876	1-23-91	PJD
C	ADDED TERMINALS TO 104390 ITEM #1 AND 104389 ITEM #12 ITEM 12 WAS 1040071 PANEL, TIMER AND ITEM 1 WAS 1040072 TRANSFORMER -E.O. 1784 R1	5-09-91	PJD

ITEM NO.	PART NO.	DESCRIPTION
13	1	104164 HARNESS, WIRING, ELECTRIC CONTROL (NOT SHOWN)
12	1	104389 TIMER ASSEMBLY, NOX
11	2	14892 KNT, HEX 10-24 ELASTIC LOCK
10	1	20478 TIMER, SET TO STATE INTERVAL 3 MINUTE
9	1	101875 KNT, HEX 1/4-20 ELASTIC LOCK
8	2	104223 KNT, HEX 8-32 ELASTIC LOCK
7	2	101855 BASED, FLAT 1/4 S/S
6	1	14817 KNT, HEX 1/4-20-STEEL
5	1	104224 SWITCH, ROCKER, SPST, WHITE CAPLINGS TIGASIT-65-AL-NAL ED.
4	1	19993 SWITCH, ROCKER, DPST, ON/OFF, 6A, 125V
3	1	104172 LABEL, CONTROL PANEL, ELECTRONIC SC 5.1
2	1	104157 PANEL
1	1	104390 TRANSFORMER ASSEMBLY

REFERENCES (EXCEPT AS SHOWN)			
CLEVELAND RANGE INC. 1233 East 111th St. Cleveland, Ohio 44110-2111			
DESIGNER	SCALE	DRAWN BY	APPROVED BY
1 N/A	N/A	R. RIOS	J.D.
ANALYZER	TITLE		
1 N/A	PANEL, CONTROL ASSEMBLY ELECTRONIC SC 5.1		
DATE	DRAWING NO.	REV.	
CK 9-11-90	C- 104238	C	

THIS DESIGN DESCRIBES A PROPRIETARY ITEM AND IS THE PROPERTY OF CLEVELAND RANGE. THIS DRAWING IS NOT TO BE COPIED OR USED WITHOUT THE APPROVAL OF CLEVELAND.

LET.	REVISIONS	BY
A	REMOVED ITEMS 5, 8, 8 & 9 REVISED ITEM 1 PICTORIAL E.O. 1878 R1 - COST REDUCTION	P.D.
B	SEE E.O. # C-1957 R 1	P.D.

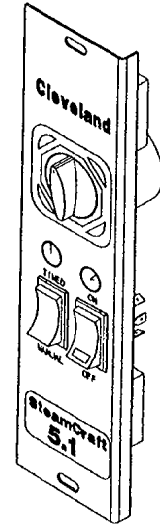
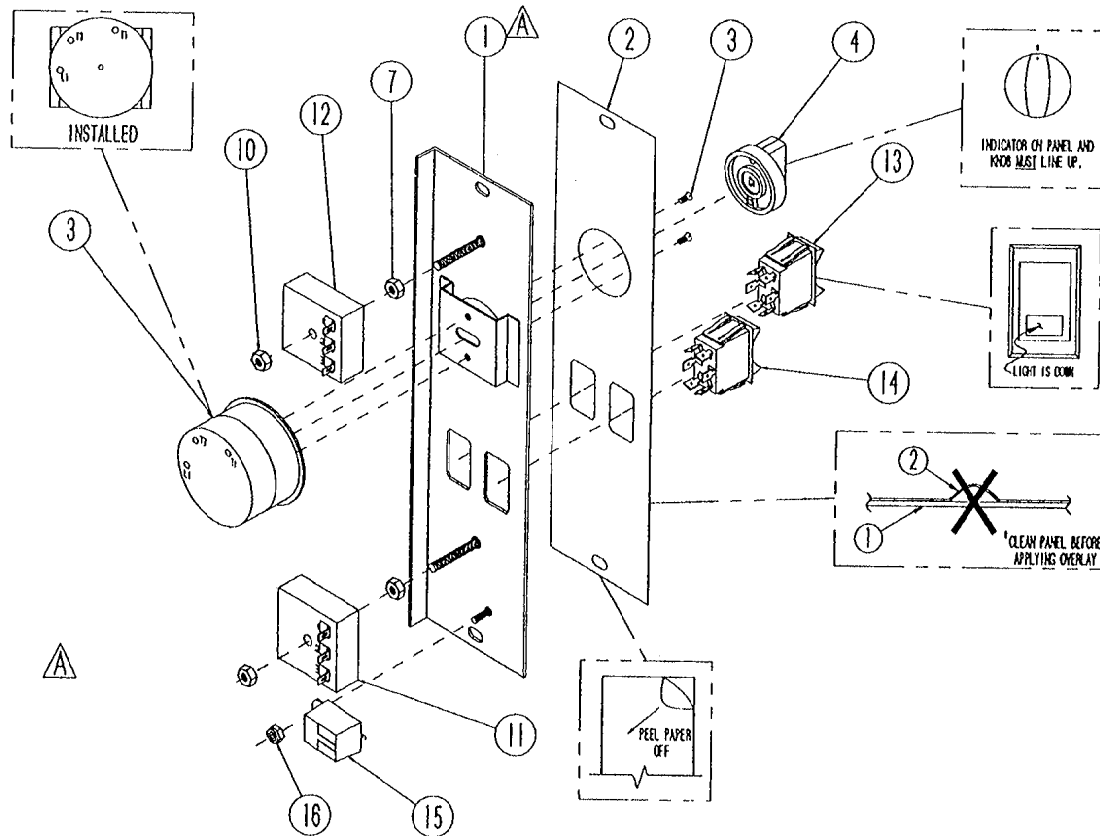

NO.	QTY.	PART NO.	DESCRIPTION
16	1	14672	#10-32 LOCKING HEX. NUT
15	1	41350	BUZZER
14	1	104224	MANUAL SWITCH
13	1	19993	POWER SWITCH
12	1	20478	3-MINUTE TIMER
11	1	20477	3-SECOND TIMER
10	2	101873	NUT, 1/4-20 ELASTIC LOCK
9			
8			
7	2	14617	BLACK OXIDE 1/4-20 HEX NUT
6			
5			
4	1	11307	TIMER KNOB
3	1	20478	TIMER WITH MOUNTING SCREWS (2)
2	1	103722	LABEL, CONTROL PANEL, MANUAL
1	1	104085	CONTROL PANEL WITH STUDS

TOLERANCES UNLESS SHOWN		CLEVELAND RANGE INC. 1333 East 175th St. Cleveland, Ohio 44110-2911		
DECIMAL 1 N/A	SCALE NONE	DRAWN BY R. RIOS	APPROVED BY J. B.	
MILLIMETER 1 N/A	TITLE CONTROL PANEL ASSEMBLY MANUAL STEAMCRAFT 5.1			
DATE 07-9-90	DRAWING NO. C-104191	REV. 0		

THIS DESIGN DESCRIBES A PROPRIETARY ITEM AND IS THE PROPERTY OF CLEVELAND RANGE. THIS DRAWING IS NOT TO BE COPIED OR USED WITHOUT THE APPROVAL OF CLEVELAND RANGE.

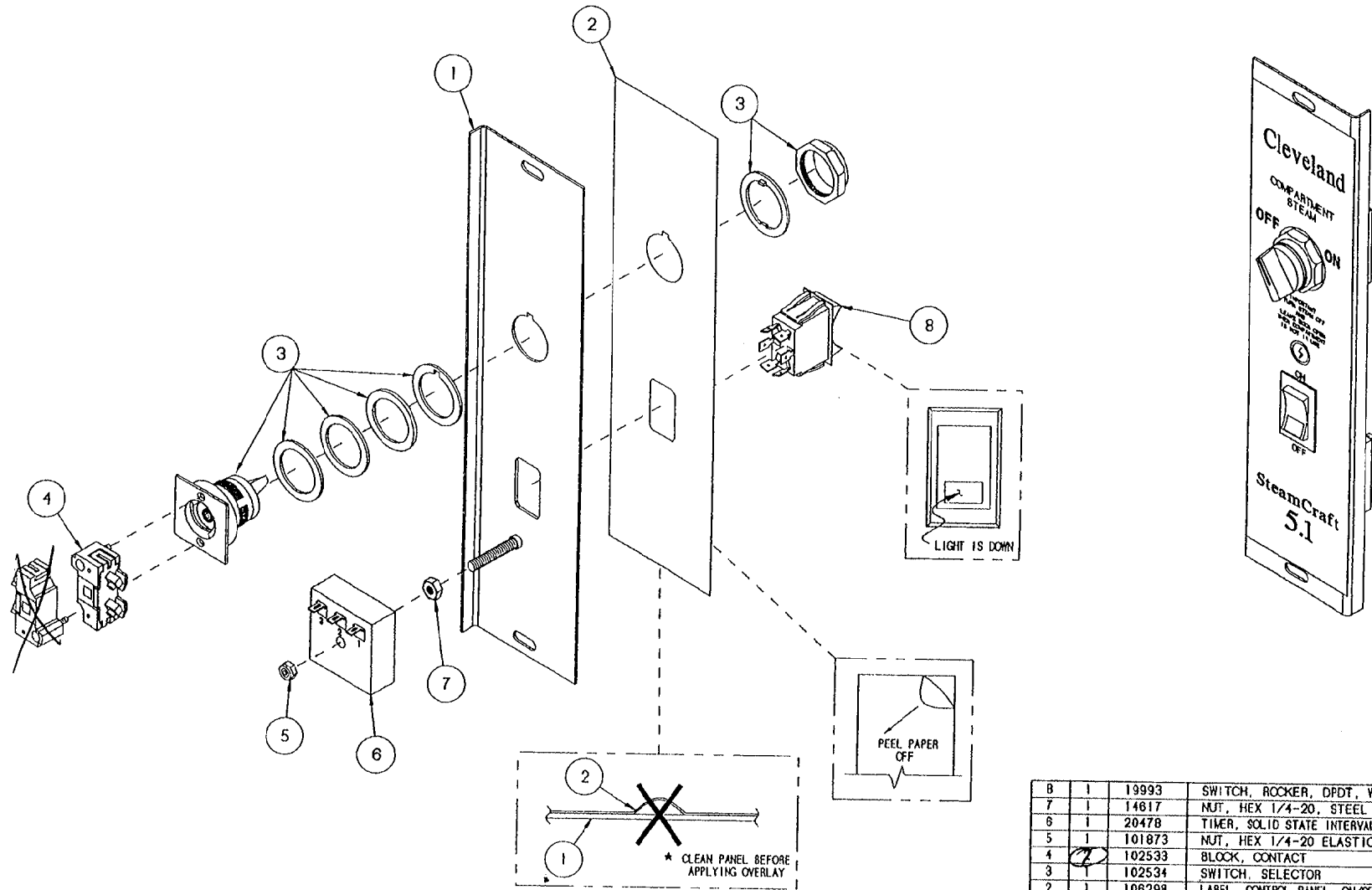

ITEM	QTY.	PART NO.	DESCRIPTION
8	1	19993	SWITCH, ROCKER, DPDT, W/ RED LIGHT
7	1	14617	NUT, HEX 1/4-20, STEEL
6	1	20478	TIMER, SOLID STATE INTERVAL 3 MINUTE
5	1	101873	NUT, HEX 1/4-20 ELASTIC LOCK
4	1	102533	BLOCK, CONTACT
3	1	102534	SWITCH, SELECTOR
2	1	106298	LABEL, CONTROL PANEL, ON/OFF, SC 5.1
1	1	106303	PANEL WELDMENT, ON/OFF CONTROL, SC 3.1/5.1

TOLERANCES (EXCEPT AS NOTED)			
DECIMAL	SCALE	DRAWN BY	APPROVED BY
± .030	5/8"=1"	DUTCHMAN	
ANGULAR	TITLE		
± 1°	PANEL ASSY, ON/OFF CONTROL STEAMCRAFT 5.1		
CK	DATE	DRAWING NO.	REV.
	01-15-93	C - 106305	-

THIS DESIGN DESCRIBES A PROPRIETARY ITEM AND IS THE PROPERTY OF CLEVELAND RANGE. THIS DRAWING IS NOT TO BE COPIED OR USED WITHOUT THE APPROVAL OF CLEVELAND RANGE.

- NOTES : 1.) USE LOCTITE #222 - LOW STRENGTH (#104146) ON ITEM 4
 2.) USE RTV (#00933) ON ITEM 6
 3.) ORIENT LONGER SIDE OF ITEM 5 TOWARD HANDLE

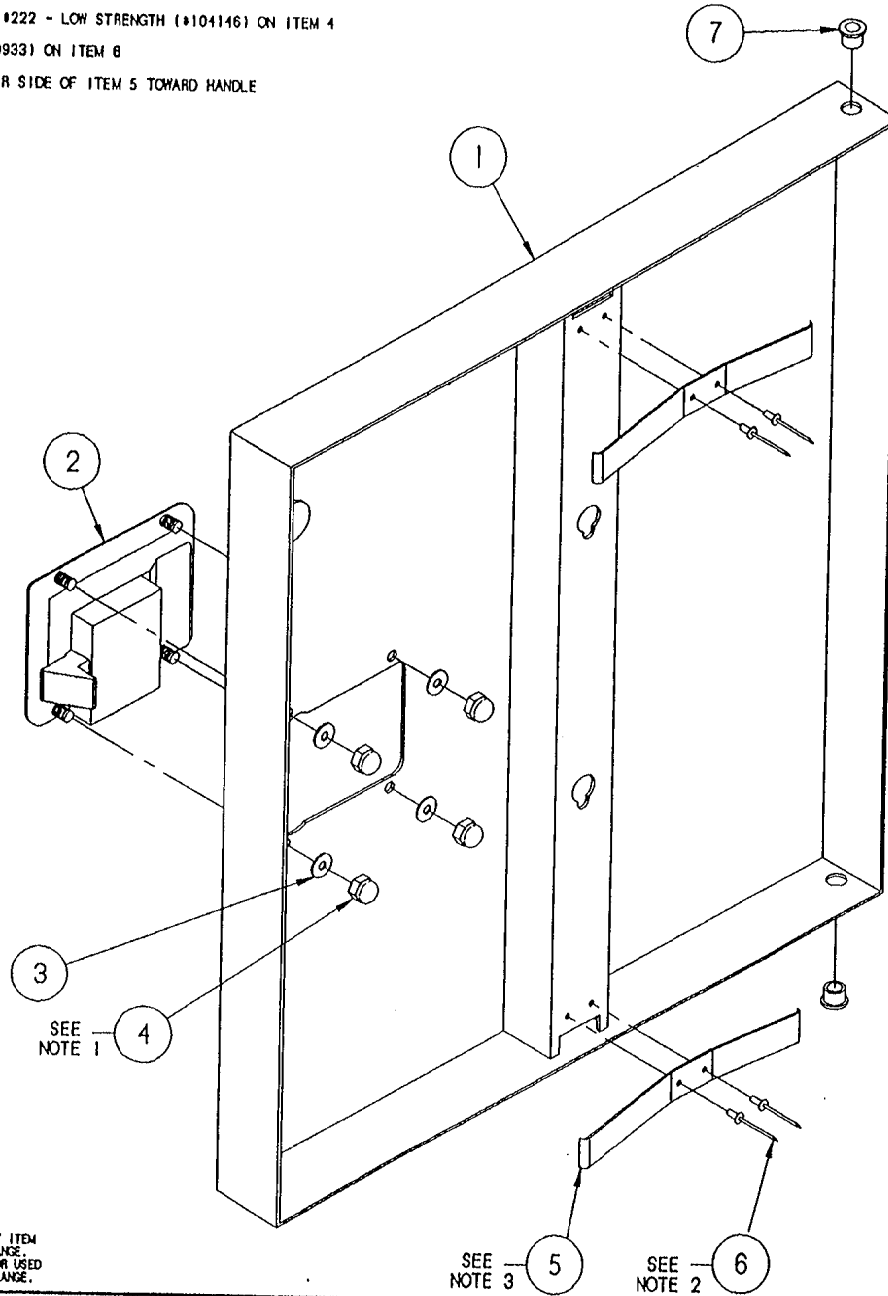

THIS DESIGN DESCRIBES A PROPRIETARY ITEM AND IS THE PROPERTY OF CLEVELAND RANGE. THIS DRAWING IS NOT TO BE COPIED OR USED WITHOUT THE APPROVAL OF CLEVELAND RANGE.

SEE NOTE 3

SEE NOTE 2

LET.	REVISIONS	DATE	BY
A	P/Ns 105901 & 104987 ADDED, PICTORIAL CHANGE, REDRAWN CADKEY PER E.O. #C-2441 R2	08-30-93	PJD
B	P/Ns 105901 & 104987 REF. ONLY PER E.O. #C-2441 R3	08-05-93	PJD
C	P/Ns 105901 & 104987 REMOVED PER E.O. #C-2441 R5	12-13-93	PJD

ITEM	QTY.	PART NO.	DESCRIPTION
7	2	103841	BUSHING, BRONZE
6	4	18357	RIVET, 1/8" DIA. FLUSH BREAK, S/S
5	2	102228	SPRING, DOOR
4	4	14879	NUT, #10-24 ACORN, S/S
3	4	101855	WASHER, #10 FLAT, S/S
2	1	103843	LATCH, DOOR - PADDLE TYPE
1	1	1042072	DOOR, OUTER WELD ASSY, W/SCS TAB, S/C S.I., H.L.

TOLERANCES (EXCEPT AS NOTED)		CLEVELAND RANGE INC. 1303 East 179th St. Cleveland, Ohio 44110-2574	
DECIMAL ± N/A	SCALE 5/8=1	DRAWN BY JTW	APPROVED BY
ANGULAR ± N/A	TITLE DOOR, OUTER ASSEMBLY, H.L. SC S.I. CONV. W/ SWITCH ACTUATOR		
CK	DATE 02-04-93	DRAWING NO. C - 1042062	REV. C

NOTES:

- 1.) USE LOCKTITE #222 - LOW STRENGTH (#101146) ON ITEM 4
- 2.) USE RTV (100933) ON ITEM 6
- 3.) ORIENT LONGER SIDE OF ITEM 5 TOWARD HANDLE

LET.	REVISIONS	DATE	BY
-	SEE E.O. 10-2411 R2	08-28-93	PJD
A	P/HS 105901 & 104987 REF. ONLY AND MOVED TO UNDER DOOR LATCH PER E.O. 10-2411 R3	08-05-93	PJD
B	P/HS 105901 & 104987 REMOVED PER E.O. 10-2411 R5	12-13-93	PJD

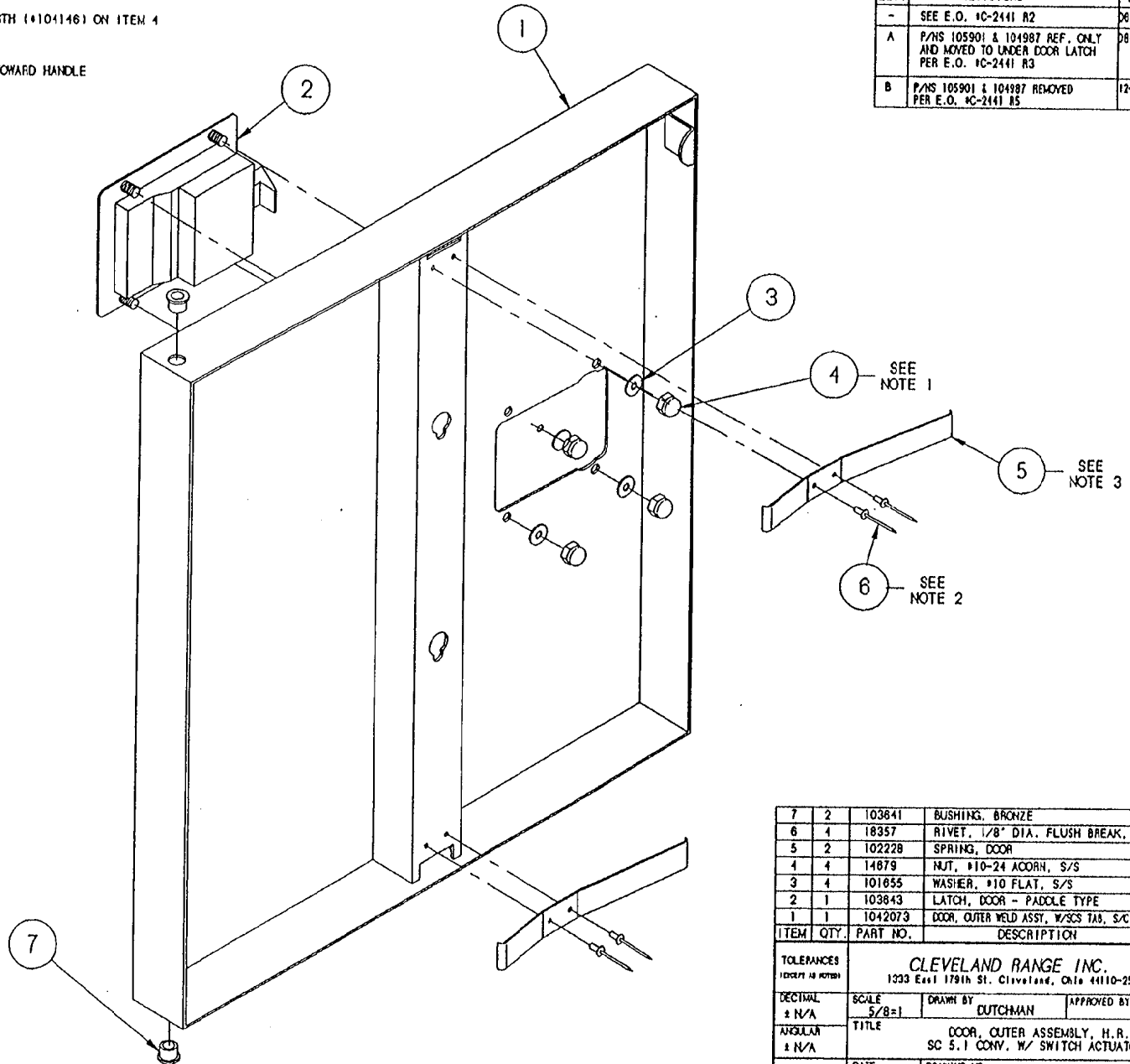

ITEM	QTY.	PART NO.	DESCRIPTION
7	2	103841	BUSHING, BRONZE
6	4	18357	RIVET, 1/8" DIA. FLUSH BREAK, S/S
5	2	102228	SPRING, DOOR
4	4	14679	NUT, #10-24 ACORN, S/S
3	4	101855	WASHER, #10 FLAT, S/S
2	1	103843	LATCH, DOOR - PADDOLE TYPE
1	1	1042073	DOOR, OUTER WELD ASSY, W/SCS TAB, S/C S.I., H.R.

<p>TOLERANCES (UNLESS NOTED OTHERWISE)</p>			
<p>CLEVELAND RANGE INC. 1333 East 179th St., Cleveland, Ohio 44110-2574</p>			
DECIMAL ± N/A	SCALE 5/8=1	DRAWN BY DUTCHMAN	APPROVED BY
ANGULAR ± N/A	TITLE DOOR, OUTER ASSEMBLY, H.R. SC S.I CONV. W/ SWITCH ACTUATOR		
CK	DATE 08-30-93	DRAWING NO. C - 1042063	REV. B

THIS DESIGN DESCRIBES A PROPRIETARY ITEM AND IS THE PROPERTY OF CLEVELAND RANGE. THIS DRAWING IS NOT TO BE COPIED OR USED WITHOUT THE APPROVAL OF CLEVELAND RANGE.

LET.	REVISIONS	DATE	BY
A	ADDED ITEMS 1 & 8, ITEM 2 WAS 104205	6/25/91	JPB

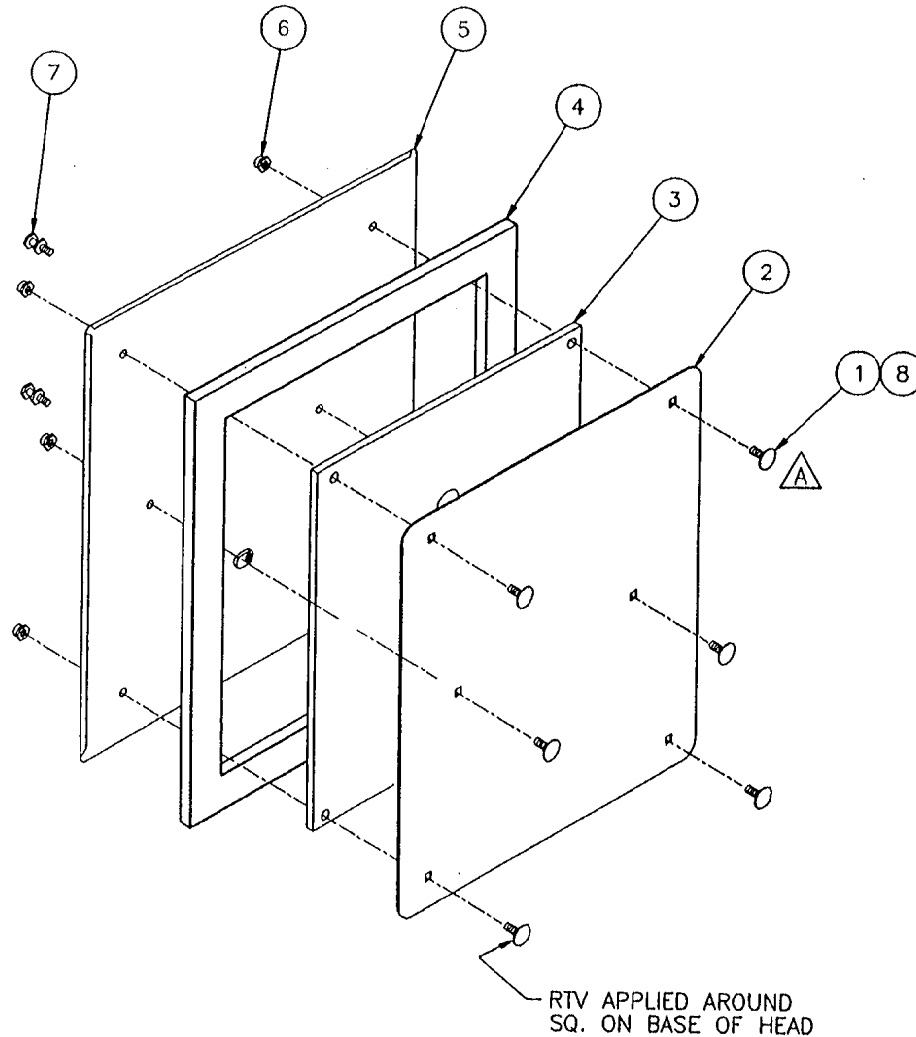

ITEM	QTY	PART NO.	DESCRIPTION
8	A/R	00932	SEALANT, CLEAR RTV
7	2	66508	STUD, DOOR MOUNTING, INNER
6	6	14665	NUT, HEX LOCK, 1/4-20 S/S
5	1	104204	DOOR WELDMENT, INNER, S/C 5.1
4	1	104026	GASKET, DOOR S/C 5.1
3	1	104022	PLATE, INNER GASKET RETAINER, S/C 5.1
2	1	104021	PLATE, GASKET RETAINER, S/C 5.1
1	6	104719	BOLT, CARRIAGE 1/4-20 X 1.000"

A

TOLERANCES (EXCEPT AS NOTED)		CLEVELAND RANGE INC. 1333 East 179th St. Cleveland, Ohio 44110-2574	
DECIMAL ± .005	SCALE NONE	DRAWN BY JPB	APPROVED BY
ANGULAR ± 1'	TITLE DOOR, INNER ASSY. STEAMCRAFT 5.1		
AC	DATE 6/25/91	DRAWING NO. B- 104202	REV A

THIS DESIGN DESCRIBES A PROPRIETARY ITEM AND IS THE PROPERTY OF CLEVELAND RANGE.
THIS DRAWING IS NOT TO BE COPIED OR USED WITHOUT THE APPROVAL OF CLEVELAND RANGE.

NOTE:

- 1) SEE DRAWING 1063573 FOR HOSE LOCATIONS.
- 2) ITEMS MARKED "REF" ARE INCLUDED IN THIS BILL OF MATERIALS FOR REFERENCE ONLY. THE "ASSEMBLED UNIT" DRAWING DEPICTS THE ACTUAL REQUIRED PARTS FOR THIS ASSEMBLY.

ASSEMBLED UNIT

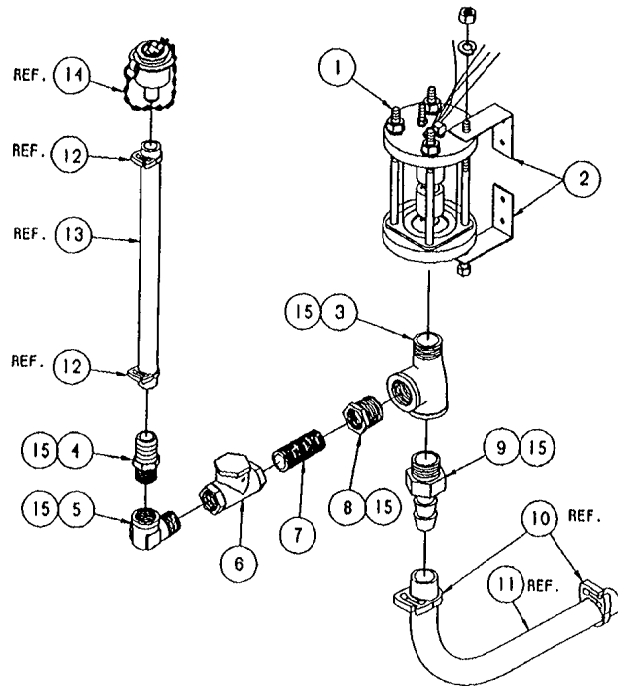
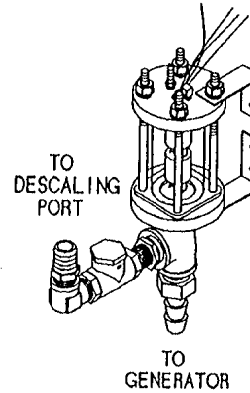

THIS DESIGN DESCRIBES A PROPRIETARY ITEM AND IS THE PROPERTY OF CLEVELAND RANGE. THIS DRAWING IS NOT TO BE COPIED OR USED WITHOUT THE APPROVAL OF CLEVELAND RANGE.

LET.	REVISIONS	DATE	BY
A	SEE E.O. 10-2631	08-02-94	PJD

SEE NOTE 2

15	A/R	00934	SEALANT, RECTORSEAL
14	1	108428	PORT ASSEMBLY, DESCALER
13	1	1058450900	HOSE, NORPRENE, 1/2 ID X 3/4 OD X 9' LG
12	1	105848	CLAMP, PLASTIC, 3/4" OD HOSE
11	1	1060931400	HOSE, SILICONE, 3/4 ID X 1 OD X 14' LG.
10	2	105847	CLAMP, PLASTIC, 1-1/8" HOSE
9	1	06240	FITTING, 3/4 H X 3/4 MPT
8	1	02565	REDUCER, 3/4 X 1/2, BRASS
7	1	14324	NIPPLE, CLOSE 1/2", BRASS
6	1	108158	CHECK VALVE, 1/2" SWING W/ RUBBER SEAT
5	1	05253	ELBOW, STREET, 90° X 1/2, BRASS
4	1	08237	FITTING, 1/2 H X 1/2 MPT, BRASS
3	1	20249	TEE, 3/4" MALE RUN, BRASS
2	2	106876	BRACKET, TOP/BOT. FLOAT SUPPORT
1	1	105877	FLOAT, ASSEMBLY, STEAMCRAFT

ITEM	QTY.	PART NO.	DESCRIPTION
TOLERANCES (EXCEPT AS NOTED)			
CLEVELAND RANGE INC.			
1333 East 179th St. Cleveland, Ohio 44110-2574			
DECIMAL	SCALE	DRAWN BY	APPROVED BY
± .030	1/4"	DUTCHMAN	
ANGULAR	TITLE		
± 1°	FLOAT AND DESCALER ASSEMBLY STEAMCRAFT 5.1, GAS		
CK	DATE	DRAWING NO.	REV.
	05-12-93	B - 106521	A

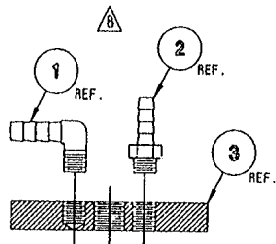

DETAIL A-A
SCALE: 1/2=1

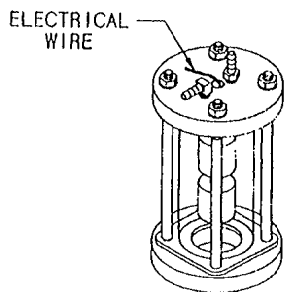

ASSEMBLED VIEW
SCALE: 1/4=1

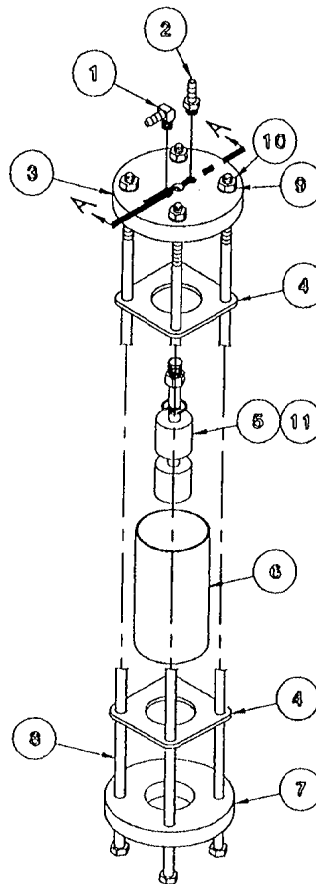

EXPLODED ASSEMBLY
SCALE: 1/4=1

REFERENCE:
260AHM 5 OF 5

LET.	REVISIONS	DATE	BY
A	CORRECTED P/N 105787	7-30-92	SM
B	ROTATED 90° P/NS 105787 & 104380 PER EO #C-2304	10-10-92	PD
C	THIS ASSEMBLY REPLACES P/N 104091 ON SC 3.1, 5.1 ELECT. & SC 10 ELECT. PER EO #C-2277 R3	02-02-93	PD

ITEM	QTY.	PART NO.	DESCRIPTION
11	A/R	00934	SEALANT, RECTORSEAL
10	4	14618	NUT, HEX HEAD, 1/4-20, S/S
9	4	23105	WASHER, SPLIT LOCK, 1/4, S/S
8	4	104276	SCREW, HEX HEAD, 1/4-20 x 5.5, S/S
7	1	104040	CAP, FLOAT BOTTOM
6	1	1040190388	TUBE, POLYSULFONE, 2 x .125 x 3.875
5	1	103726	SWITCH ASSEMBLY, FLOAT
4	2	104041	GASKET, FLOAT ASSEMBLY
3	1	104039	TOP, FLOAT, STEAMCRAFT
2	1	104380	FITTING, HOSE BARB, 1/4 H x 1/8 MPT
1	1	105787	FITTINGS, HOSE BARB, 90°, 1/4 H x 1/8 MPT

TOLERANCES (EXCEPT AS NOTED)		CLEVELAND RANGE INC. 1333 East 179th St. Cleveland, Ohio 44110-2574	
DECIMAL ± N/A	SCALE AS SHOWN	DRAWN BY S. MILEWSKI	APPROVED BY
ANGULAR ± N/A	TITLE △ FLOAT ASSEMBLY, STEAMCRAFT 10 ELECTRIC, 3.1 AND 5.1		
CK	DATE 05-28-92	DRAWING NO. B - 105877	REV. C

THIS DESIGN DESCRIBES A PROPRIETARY ITEM AND IS THE PROPERTY OF CLEVELAND RANGE. THIS DRAWING IS NOT TO BE COPIED OR USED WITHOUT THE APPROVAL OF CLEVELAND RANGE.

108727

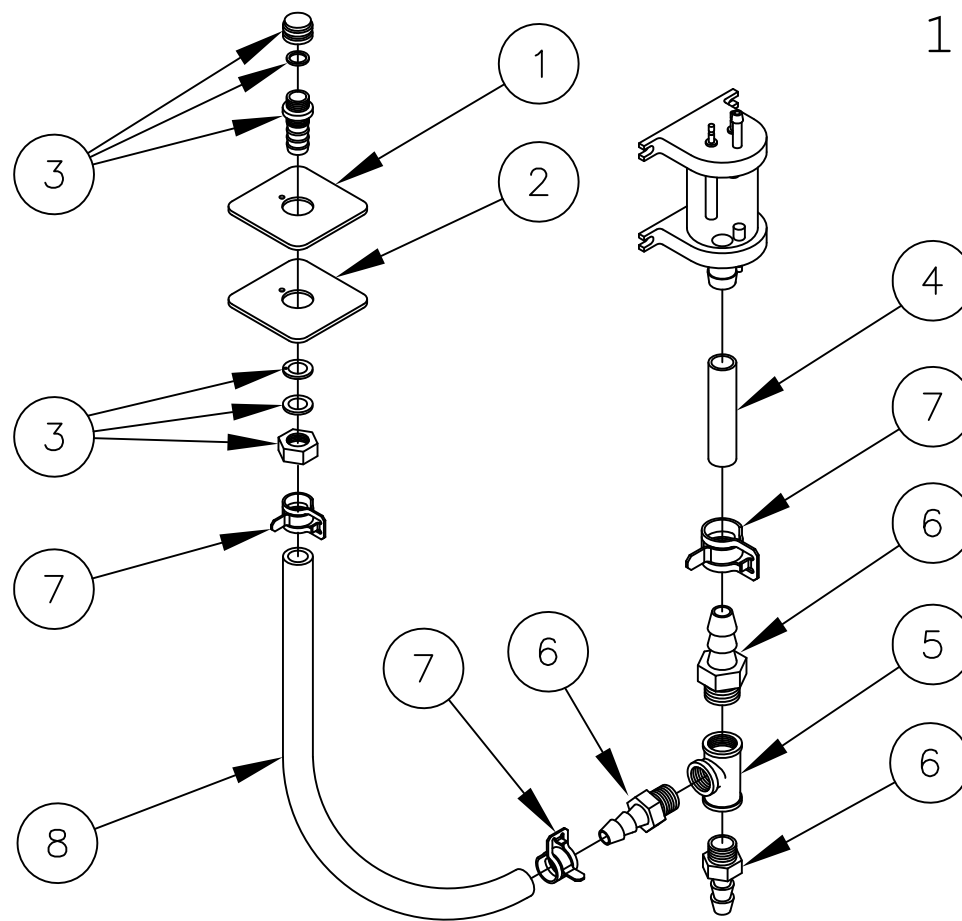

8	1	085112700	HOSE, WHITE, EPDM, 3/4 ID X 27.000 LG
7	2	107312	CLAMP, HOSE METAL TENSION, 1.125 OD HOSE
6	2	06240	FITTING, HOSE BARB, 3/4 X 3/4
5	1	20206	TEE, 3/4 BRASS
4	1	085110600	HOSE, WHITE, EPDM, 3/4 ID X 6.000
3	1	109641	PORT ASSEMBLY, DESCALER
2	1	108724	PLATE, DESCALER PORT CVRSN
1	1	108723	GASKET, DESCALER PORT CVRSN

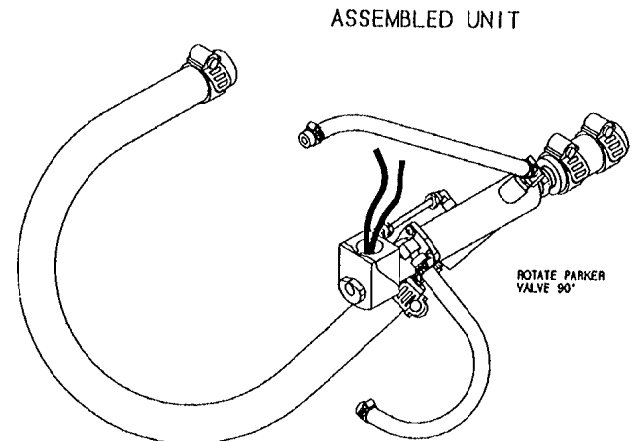
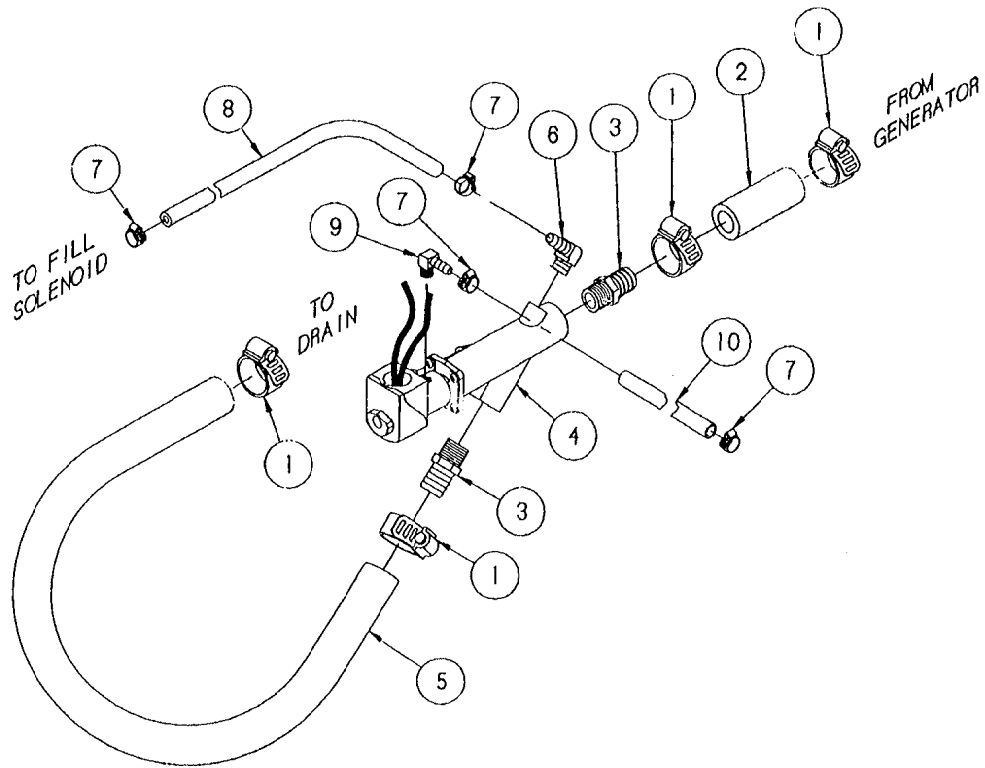

ITEM	QTY.	PART NO.	DESCRIPTION
10	1	1058500600	HOSE, NT-80, 1/4 X 1/2 X 6" LG.
9	1	105787	FITTING, HOSE 1/4 H X 1/8 NPT, 90°
8	1	1058500900	HOSE, NT-80, 1/4 X 1/2 X 9" LG.
7	4	03207	CLAMP, METAL, WORM DRIVE
6	1	105786	FITTING, HOSE 1/4 H X 1/4 NPT, 90°
5	1	085051400	HOSE, DARTPREEN 3/4" ID X 14" LG.
4	1	22244	VALVE, DRAIN, PARKER
3	2	06240	FITTING, HOSE 3/4 H X 3/4 NPT, STR
2	1	085050300	HOSE, DARTPREEN 3/4" ID X 3" LG.
1	4	03207	CLAMP, METAL, WORM DRIVE

TOLERANCES (EXCEPT AS NOTED)			
CLEVELAND RANGE INC. 1333 East 179th St., Cleveland, Ohio 44110-2574			
DECIMAL ± N/A	SCALE 3/8=1	DRAWN BY DUTCHMAN	APPROVED BY
ANGULAR ± N/A	TITLE VALVE ASSEMBLY, DRAIN STEAMCRAFT 5.1, GAS		
CK	DATE 05-12-93	DRAWING NO. C - 106524	REV. -

THIS DESIGN DESCRIBES A PROPRIETARY ITEM AND IS THE PROPERTY OF CLEVELAND RANGE. THIS DRAWING IS NOT TO BE COPIED OR USED WITHOUT THE APPROVAL OF CLEVELAND RANGE.

LET.	REVISIONS	DATE	BY
A	ADDED NOTE FOR ASSEMBLY.	04/13/99	NT

NOTE: 1) Rotate solenoid valve 45° clockwise for left hinging units. Rotate solenoid valve 45° counter-clockwise for right hinging units.

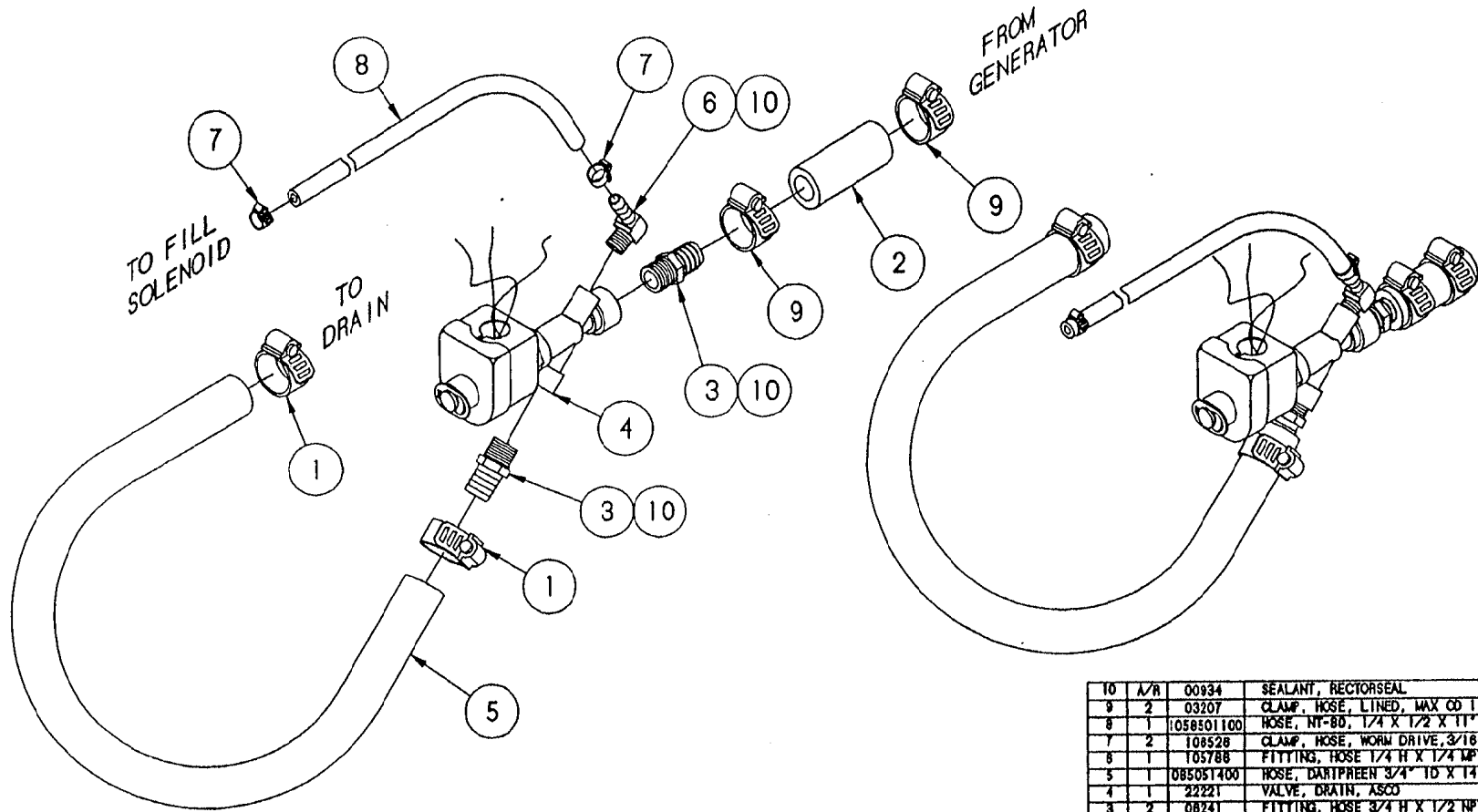

ITEM	QTY.	PART NO.	DESCRIPTION
10	A/R	00934	SEALANT, RECTORSAL
9	2	03207	CLAMP, HOSE, LINED, MAX OD 1.125"
8	1	1058501100	HOSE, NI-80, 1/4 X 1/2 X 11" LG.
7	2	108528	CLAMP, HOSE, WORM DRIVE, 3/16-3/16
6	1	105788	FITTING, HOSE 1/4 H X 1/4 MPY, 90°
5	1	085051400	HOSE, DARTPREEN 3/4" ID X 14" LG.
4	1	22221	VALVE, DRAIN, ASCO
3	2	08241	FITTING, HOSE 3/4 H X 1/2 NPT, 8TH
2	1	085110300	HOSE, STILBRAD, 3/4" ID X 3" LG.
1	2	03204	CLAMP, HOSE, WORM DRIVE, 3/4"

TOLERANCES
(UNLESS OTHERWISE SPECIFIED)

CLEVELAND RANGE INC.
1233 East 179th St., Cleveland, Ohio 44110-2574

DESIGNER: [blank] SCALE: 1/2" = 1" DRAWN BY: DUTCHMAN APPROVED BY: [blank]

ANELLAR: [blank] TITLE: VALVE ASSEMBLY, DRAIN STEAMCRAFT 3.1 AND 5.1

DATE: 02-12-93 DRAWING NO.: C - 106384 REV. A

THIS DESIGN DESCRIBES A PROPRIETARY ITEM AND IS THE PROPERTY OF CLEVELAND RANGE. THIS DRAWING IS NOT TO BE COPIED OR USED WITHOUT THE APPROVAL OF CLEVELAND RANGE.

NOTE:

1. USE THREAD JOINT COMPOUND AS REQUIRED TO SEAL.

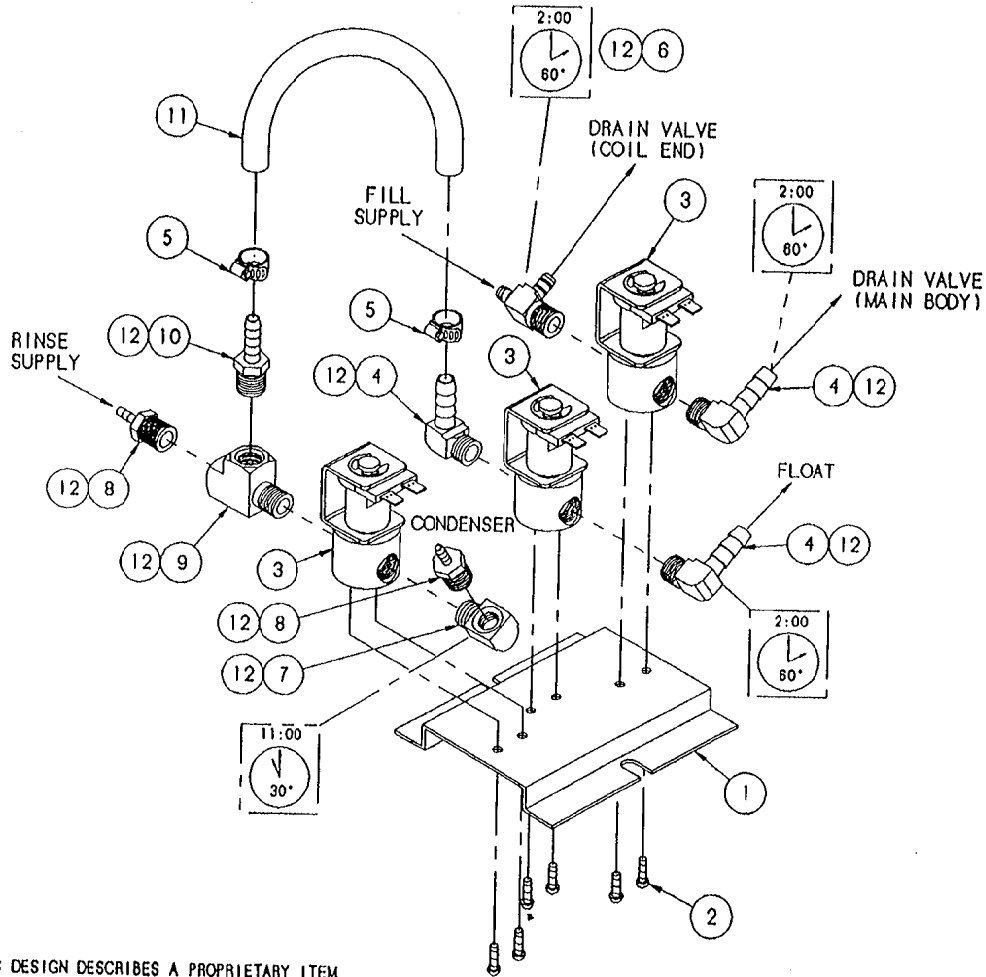

THIS DESIGN DESCRIBES A PROPRIETARY ITEM AND IS THE PROPERTY OF CLEVELAND RANGE. THIS DRAWING IS NOT TO BE COPIED OR USED WITHOUT THE APPROVAL OF CLEVELAND RANGE.

LET.	REVISIONS	DATE	BY
A	106522 REPLACED 104087, 106526 REPLACED 106219, ADDED NEW PARTS & NEW TUBING LAYOUT PER E.O. #C-2492	08-23-93	PJD

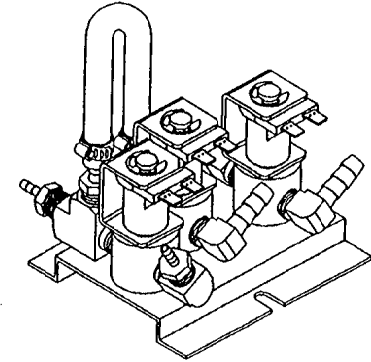

SEE NOTE 1

ITEM	QTY.	PART NO.	DESCRIPTION
		12 A/R 00934	SEALANT, RECTORSEAL
▲	11	1	1058500600 TUBING, NT-80, 1/4" X 6"
	10	1	104381 FITTING, HOSE, 1/4 H X 1/4 MPT, STR.
▲	9	1	106663 FITTING, MALE RUN, 1/4 MPT X 1/4 FPT
▲	8	2	106661 FITTING, HOSE, 1/8 H X 1/4 MPT, STR.
▲	7	1	05235 ELBOW, STREET 1/4 X 90°, BRASS
	6	1	106588 FITTING, TEE, 1/4 H X 1/4 MPT X 1/4 H
▲	5	2	106526 CLAMP, HOSE, 3/8 X 5/8 X 5/16 W
	4	3	105786 FITTING, HOSE, 1/4 H X 1/4 MPT, 90°
	3	3	22218 SOLENOID VALVE
	2	6	101872 SCREW, #8-32 X 1/4 THD. CUT
	1	1	104284 BRACKET, MOUNTING

TOLERANCES (EXCEPT AS NOTED)		CLEVELAND RANGE INC. 1333 East 179th St. Cleveland, Ohio 44110-2574	
DECIMAL ± N/A	SCALE 1/2" = 1"	DRAWN BY ARB	APPROVED BY
ANGULAR ± 1°	TITLE VALVE ASSY, WATER INLET SC 3.1 & 5.1, H.L.		
CK	DATE 08-24-93	DRAWING NO. B - 106522	REV. A

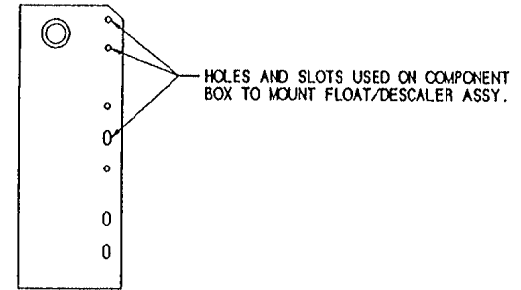
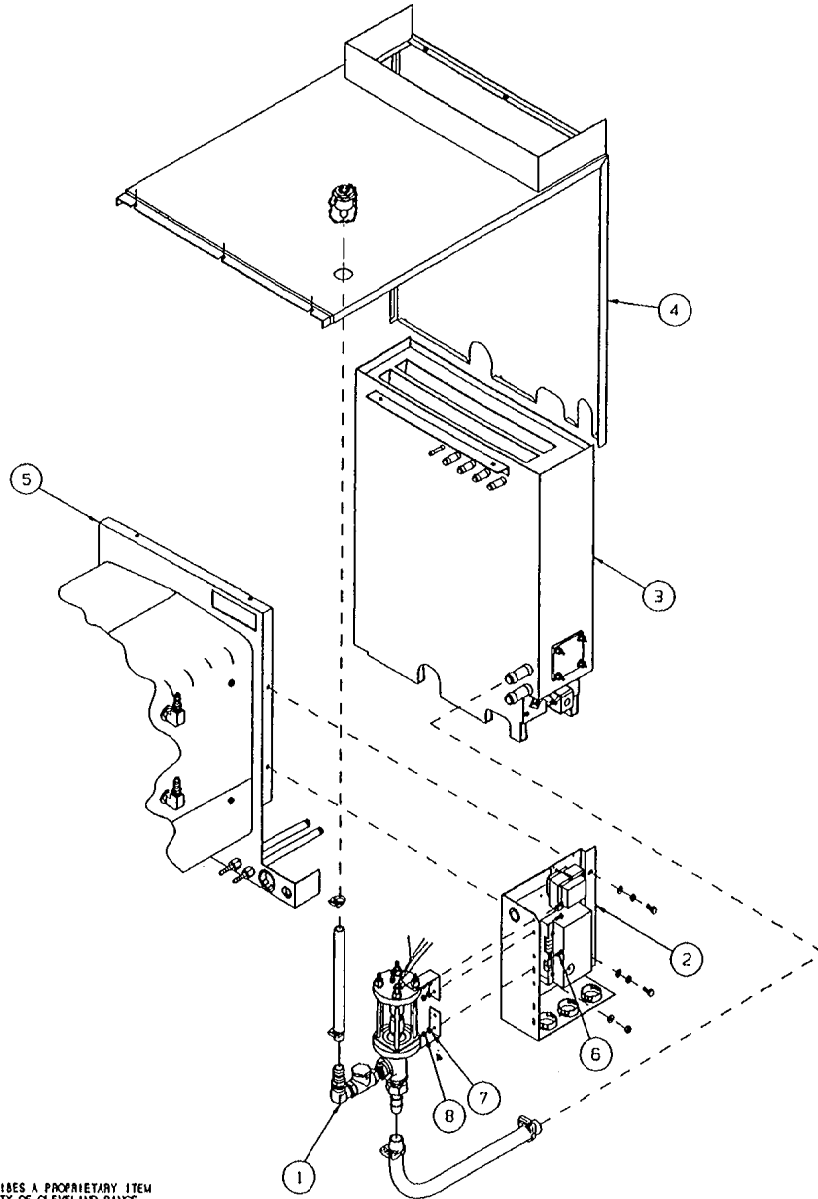

ITEM	QTY	PART NO.	DESCRIPTION
8	3	14892	NUT, HEX LOCK ELASTIC 10-24
7	3	101655	WASHER, FLAT #10, S/S
6	3	19287	SCREW, PAN HEAD 10-24 X 1/2, S/S
5	-	1041971	CAVITY, WELD ASSY., H.L.
4	-	106398	SHEETING, TOP/BACK
3	-	106407	GENERATOR ASSY.
2	1	106523	COMPONENT PANEL ASSY.
1	1	106521	FLOAT AND DESCALER ASSY.

THIS DESIGN DESCRIBES A PROPRIETARY ITEM AND IS THE PROPERTY OF CLEVELAND RANGE. THIS DRAWING IS NOT TO BE COPIED OR USED WITHOUT THE APPROVAL OF CLEVELAND RANGE.

TOLERANCES (UNLESS AS NOTED)		CLEVELAND RANGE INC. 1333 East 179th St., Cleveland, Ohio 44110-2574	
DECIMAL ± N/A	SCALE 3/16=1	DRAWN BY DUTCHMAN	APPROVED BY
ANGULAR ± N/A	TITLE INSTALLATION OF FLOAT/DESCALER TO COMPONENT BOX ON ULTRA 5 GAS		
CK	DATE 07-14-94	DRAWING NO. C - 260AKY	REV. -

LET.	REVISIONS	DATE	BY
A	SEE E.O. KC-2732	12-16-94	PJD

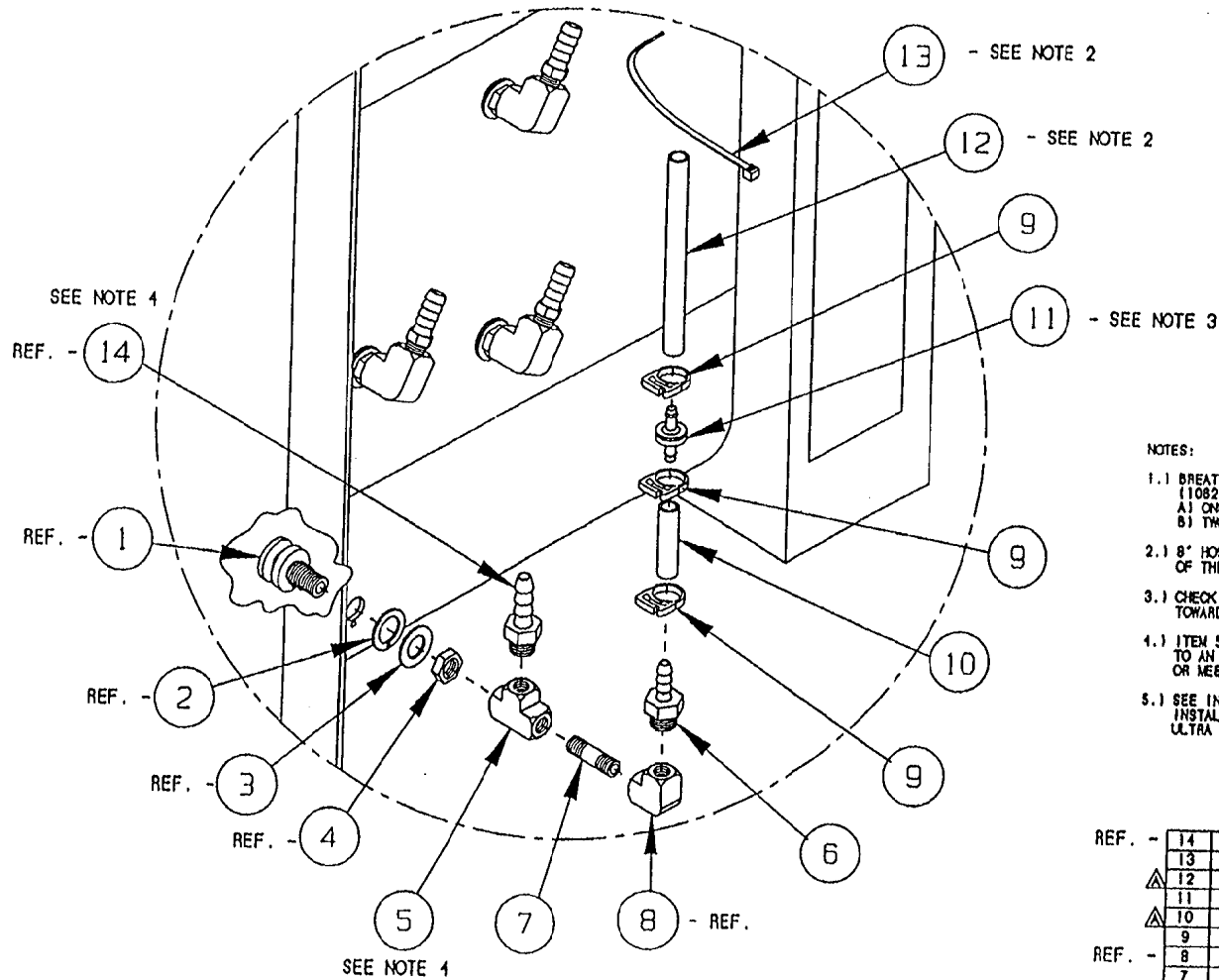

NOTES:

- 1.1 BREATHER ASSY. (1070591) TO REPLACE ONE SPRAY NOZZLE ASSY. (1082301) ONE PLACE PER CAVITY ON ALL STEAMCRAFT ULTRA UNITS
A) ONE COMPARTMENT UNITS = ONE BREATHER ASSY.
B) TWO COMPARTMENT UNITS = TWO BREATHER ASSY.
- 2.1 8' HOSE IS TO BE SECURED WITH NYLON CABLE TO THE HOSE OF THE SPRAY NOZZLE ASSY. DIRECTLY ABOVE THE NEW ASSY.
- 3.1 CHECK VALVE - SIDE WHICH READS "VAC" MUST FACE DOWN TOWARD HOSE BARB
- 4.1 ITEM 5 (P/N 20199) AND ITEM 6 (P/N 104048) TO BE ROTATED TO AN ANGLE THAT WILL MATCH THE OTHER SPRAY NOZZLES OR MEET A MATING HOSE FITTING
- 5.1 SEE INSTRUCTIONAL DRAWINGS 280ALB1-280ALB7 FOR INSTALLATION OF THIS ASSEMBLY INTO THE STEAMCRAFT ULTRA UNITS.

REF.	QTY.	PART NO.	DESCRIPTION
REF. - 14	-	104048	FITTING, 1/2 HOSE X 1/4 MPT
13	1	20451	TIE, NYLON CABLE
△ 12	1	1043790500	HOSE, SILICONE 1/4 ID X 1/2 OD X 5
11	1	107032	CHECK VALVE, PLASTIC DIAPHRAGM
△ 10	1	1043790300	HOSE, SILICONE 1/4 ID X 1/2 OD X 3
9	3	104383	CLAMP, HOSE, NYLON
REF. - 8	-	05236	ELBOW, 1/4 X 90°, BRASS
7	1	14411	NIPPLE, 1/4 X 1.5", BRASS
6	1	104381	FITTING, 1/4 HOSE X 1/4 MPT
5	1	20199	TEE, 1/4 BRASS
4	-	104081	NUT, HEX JAM 5/8-18 BRASS
REF. - 3	-	104232	WASHER, FLAT S/S
2	-	104082	GASKET, STEAM INJECTOR
1	-	104009	FITTING ASSY., STEAM SUPPLY
ITEM	QTY.	PART NO.	DESCRIPTION

TOLERANCES (UNLESS AS NOTED)			
CLEVELAND RANGE INC. 1333 East 179th St. Cleveland, Ohio 44110-2574			
DECIMAL ± N/A	SCALE 3/16±1	DRAWN BY DUTCHMAN	APPROVED BY
ANGULAR ± N/A	TITLE BREATHER/SPRAY NOZZLE ASSY. (1/2' HOSE) STEAMCRAFT ULTRA 3, 5 & 10		
CK	DATE 09-15-94	DRAWING NO. C - 1070591	REV. A

THIS DESIGN DESCRIBES A PROPRIETARY ITEM AND IS THE PROPERTY OF CLEVELAND RANGE. THIS DRAWING IS NOT TO BE COPIED OR USED WITHOUT THE APPROVAL OF CLEVELAND RANGE.

REV.	REVISIONS	DATE	BY
A	103936 WAS P103936, 106128 & 106127 WERE #10 SCREWS, ADDED 15010 & 18358 PER ED #C-2502	09-14-93	PJD
B	P/N 106754 WAS 106127, REMOVED S/N TAG PER ED #C2548	01/14/13	DFA

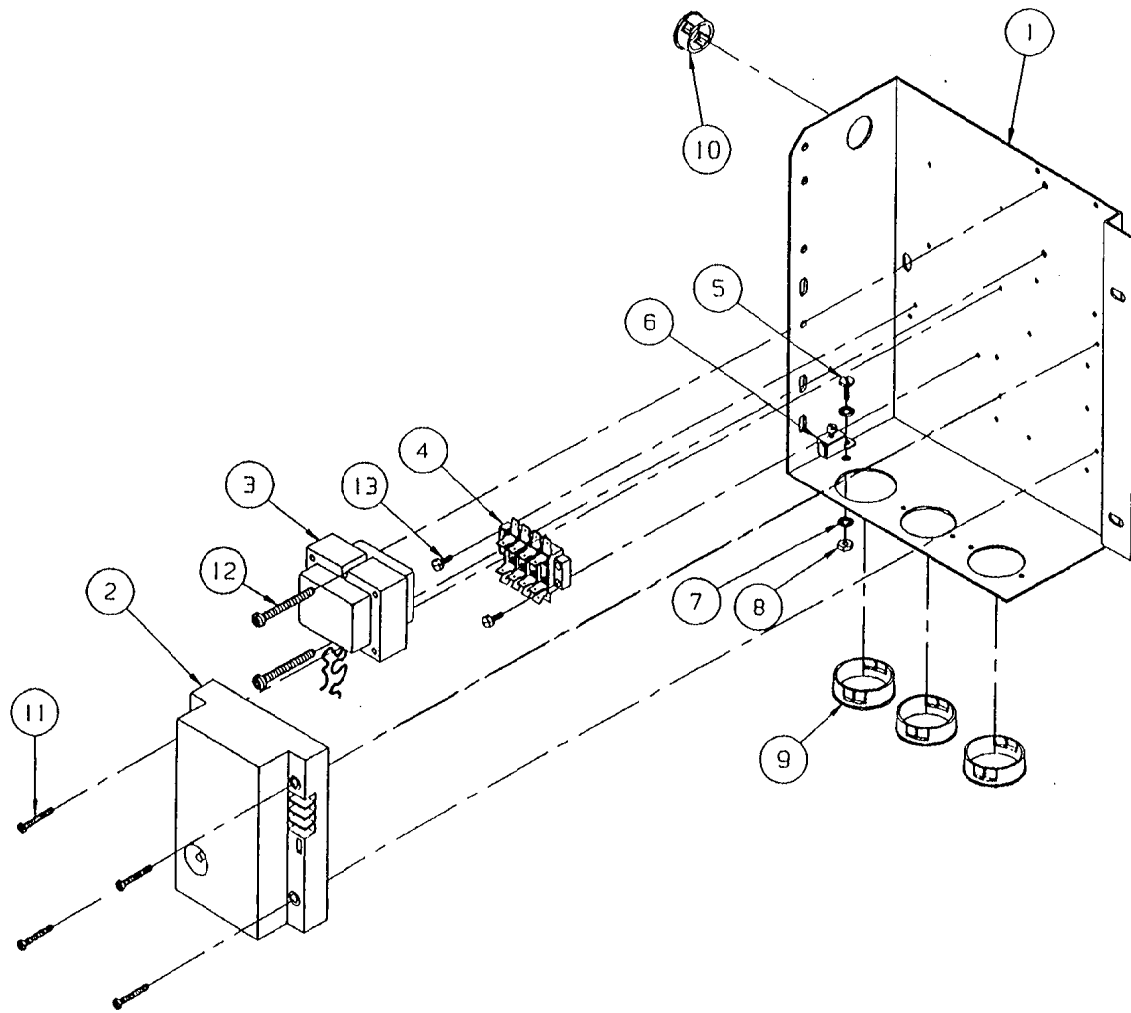

ASSEMBLED UNIT

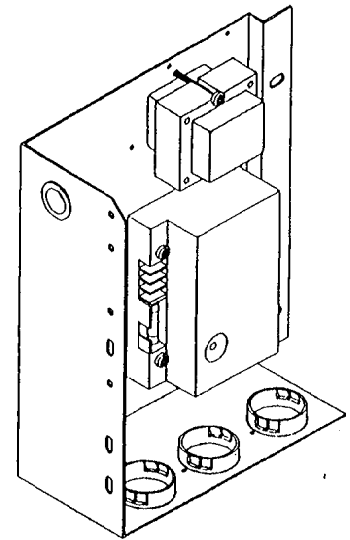

ITEM	QTY.	PART NO.	DESCRIPTION
1	1	103936	PANEL, COMPONENT WELD ASSY.
2	1	03546	SPARK IGNITION CONTROL MODULE
3	1	20528	TRANSFORMER, 24 VOLT
4	1	44164	TERMINAL BLOCK, 4 POLE
5	1	101231	SCREW, 10-24 X 1/2 TRUSS HEAD
6	1	20304	GROUND LUG, BURNOY #KPABC
7	1	23114	WASHER, INTERNAL TOOTH #10 S/S
8	1	14659	NUT, HEX 10-24 S/S
9	3	102591	BUSHING, INSULATOR
10	1	02600	BUSHING, INSULATOR, HEYCO SB-875-11
11	4	106128	SCREW, TORX SLOT #6 X 1.000
12	2	106125	SCREW, TORX SLOT #10 X 1.750
13	2	106754	SCREW, HEX/WASHER HEAD #6 X 3/8"

TOLERANCES (EXCEPT AS NOTED)			
CLEVELAND RANGE INC. 1333 East 179th St. Cleveland, Ohio 44110-2574			
DECIMAL ± N/A	SCALE 1/2=1	DRAWN BY DUTCHMAN	APPROVED BY
ANGULAR ± N/A	TITLE COMPONENT, PANEL, H.L. STEAMCRAFT 5.1, GAS		
CK	DATE 05-12-93	DRAWING NO. C - 106523	REV. B

THIS DESIGN DESCRIBES A PROPRIETARY ITEM AND IS THE PROPERTY OF CLEVELAND RANGE. THIS DRAWING IS NOT TO BE COPIED OR USED WITHOUT THE APPROVAL OF CLEVELAND RANGE.

NOTE:

1.) ROTATE 45° ITEMS 4, 5, 6, 7 AND 8

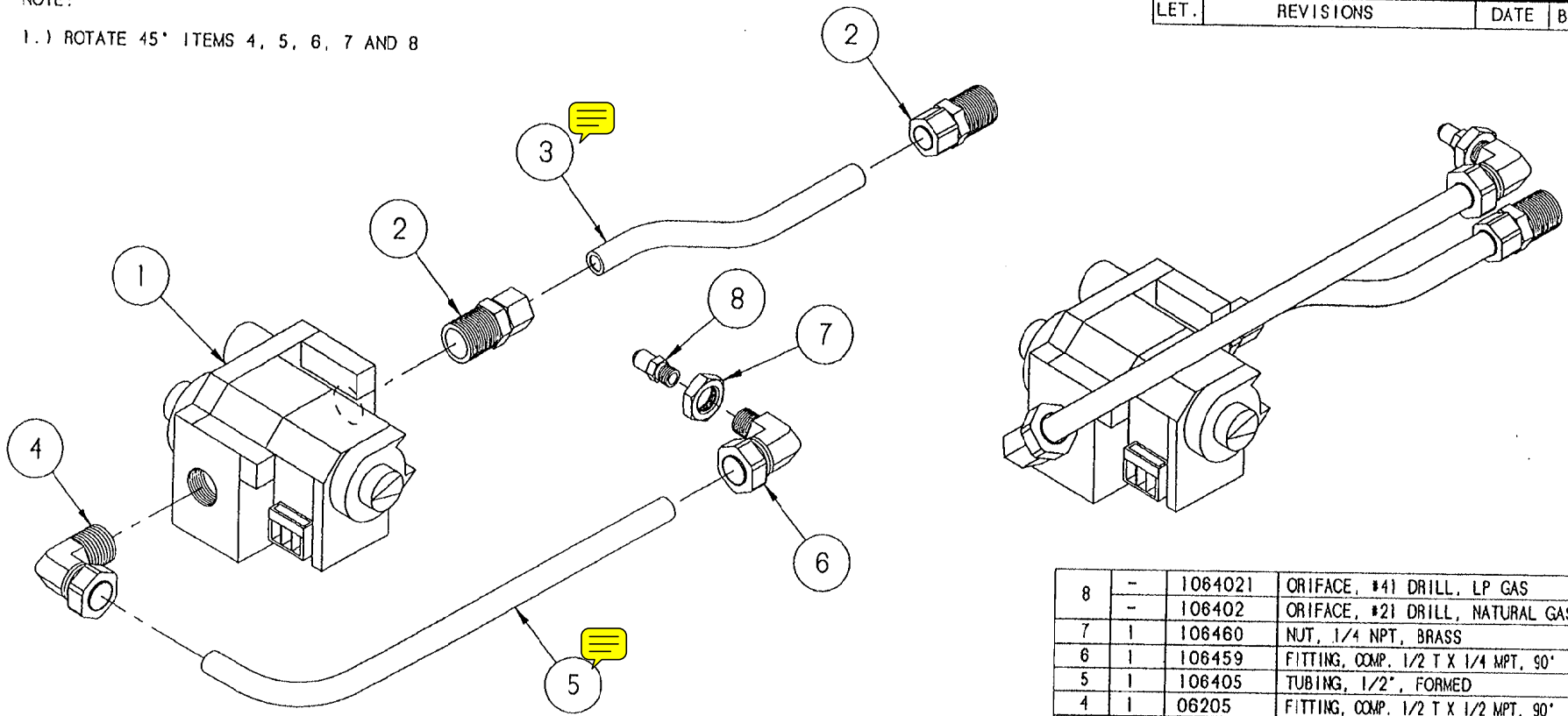

LET.	REVISIONS	DATE	BY
------	-----------	------	----

ITEM	QTY.	PART NO.	DESCRIPTION
8	-	1064021	ORIFACE, #41 DRILL, LP GAS
	-	106402	ORIFACE, #21 DRILL, NATURAL GAS
7	1	106460	NUT, 1/4 NPT, BRASS
6	1	106459	FITTING, COMP. 1/2 T X 1/4 MPT, 90°
5	1	106405	TUBING, 1/2", FORMED
4	1	06205	FITTING, COMP. 1/2 T X 1/2 MPT, 90°
3	1	106406	TUBING, 1/2", FORMED
2	2	06204	FITTING, COMP. 1/2 T X 1/2 MPT, STRA.
1	-	1064001	GAS VALVE, LP
	-	106400	GAS VALVE, NATURAL

TOLERANCES (EXCEPT AS NOTED)		CLEVELAND RANGE INC. 1333 East 179th St. Cleveland, Ohio 44110-2574	
DECIMAL ± N/A	SCALE 1/2=1	DRAWN BY DUTCHMAN	APPROVED BY
ANGULAR ± N/A	TITLE GAS VALVE ASSEMBLY SC 5.1, GAS, LP & NATURAL		
CK	DATE 06-14-93	DRAWING NO. 1064041 LP B - 106404 NAT.	REV. -

THIS DESIGN DESCRIBES A PROPRIETARY ITEM AND IS THE PROPERTY OF CLEVELAND RANGE. THIS DRAWING IS NOT TO BE COPIED OR USED WITHOUT THE APPROVAL OF CLEVELAND RANGE.

NOTE: ALL DIMENSIONS $\pm .125"$, UNLESS OTHERWISE SPECIFIED.

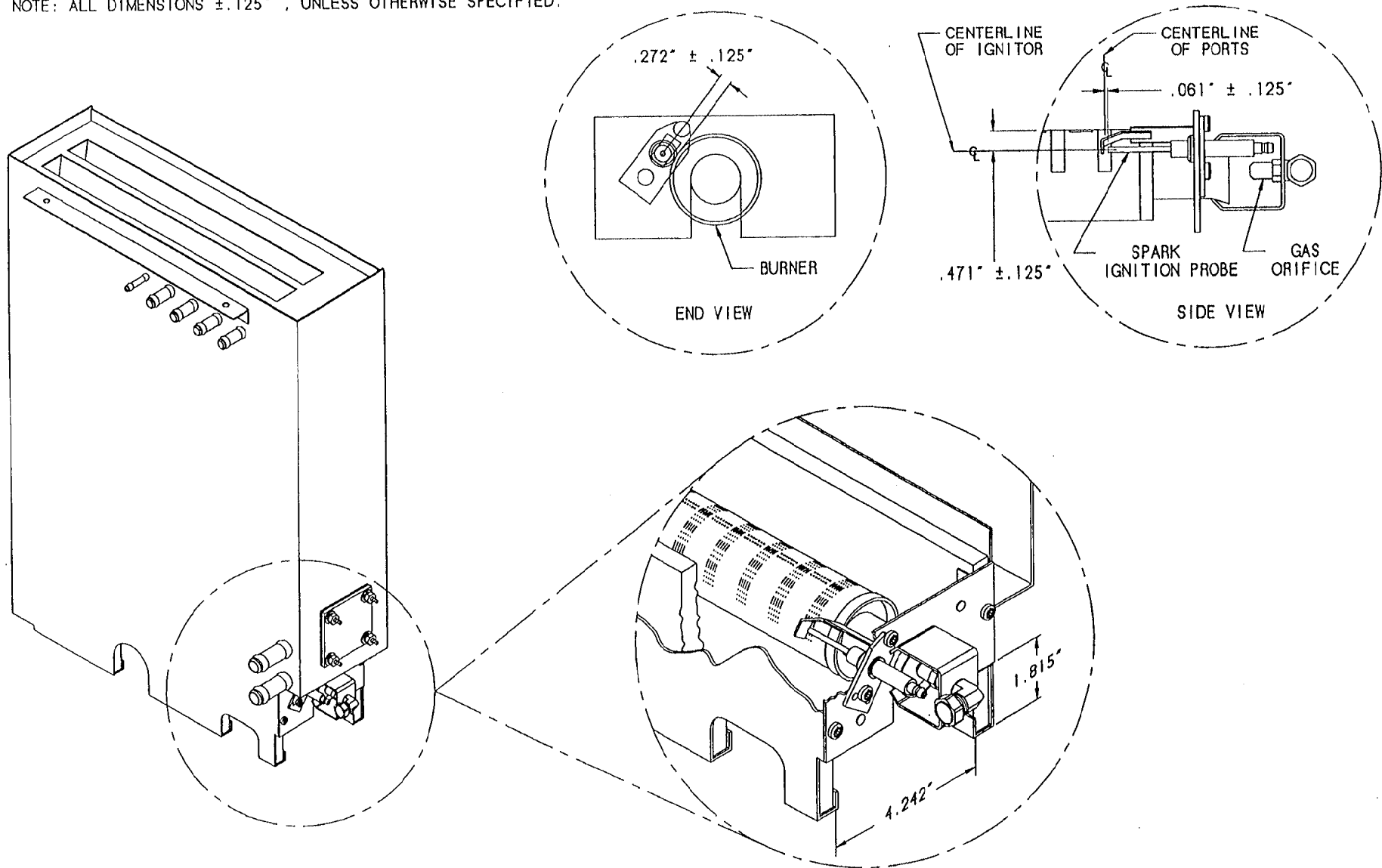

**CLEVELAND RANGE INC. STEAMCRAFT 5.1 GAS
SPARK IGNITION PROBE LOCATION, DWG. 106407G**

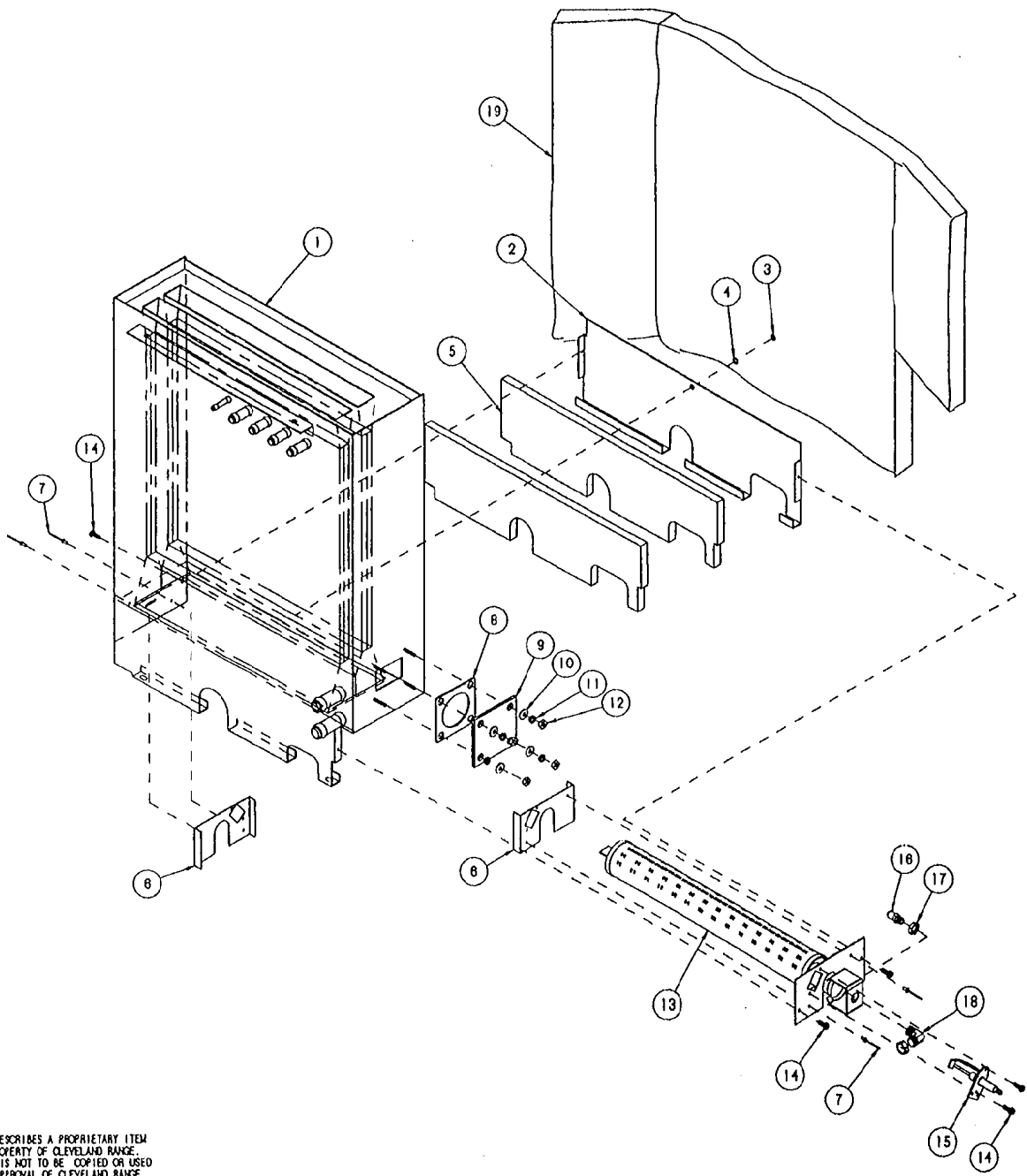

NO.	QTY.	PART NO.	DESCRIPTION
19	1	108408	INSULATION, GENERATOR WRAP
18	-	108459	FITTING, COMP. 1/2 T X 1/4 NPT, 90°, MODIFIED
17	-	108460	NUT, 1/4 NPT, BRASS
16	-	1084021	ORIFACE, #41 DRILL, LP GAS
	-	108402	ORIFACE, #21 DRILL, NATURAL GAS
15	1	05101	PROBE, SPARK IGNITION
14	5	108123	SCREW, TORX SLOT, #10 X 1/2
13	1	108582	BURNER, WELD ASSEMBLY
12	4	14618	NUT, HEX, 1/4-20
11	4	23105	WASHER, LOCK, 1/4" S/S
10	4	23118	WASHER, FLAT, 1/4" X 5/8"
9	1	10546	COVER, BLOCK-OFF
8	1	07128	HEATER GASKET
7	4	18358	RIVET, 1/8 DIA. FLUSH BREAK S/S
6	2	108362	BRACKET, SIDE, INSULATION SUPPORT
5	2	108360	INSULATION, CUT, COMBUSTION CHAMBER
4	1	23114	WASHER, LOCK, INT. TOOTH, #10-32
3	1	14645	NUT, HEX #10-32 ZINC PLATED
2	1	108361	BRACKET, REAR, INSULATION SUPPORT
1	1	108369	GENERATOR ASSY, WELD, SCS I GAS
NO.	QTY.	PART NO.	DESCRIPTION

Cleveland Range Inc. 1333 East 178th St. Cleveland, Ohio 44110-2574			
DECIMAL ± N/A	SCALE 1/4"=1	DRAWN BY DUTCHMAN	APPROVED BY J. B.
ANGULAR ± N/A	TITLE GENERATOR ASSEMBLY WITH SPARK IGNITION PROBE STEAMCRAFT 5.1, GAS		
CK	DATE 06-14-93	DRAWING NO. C-108407	REV. -

THIS DESIGN DESCRIBES A PROPRIETARY ITEM AND IS THE PROPERTY OF CLEVELAND RANGE. THIS DRAWING IS NOT TO BE COPIED OR USED WITHOUT THE APPROVAL OF CLEVELAND RANGE.

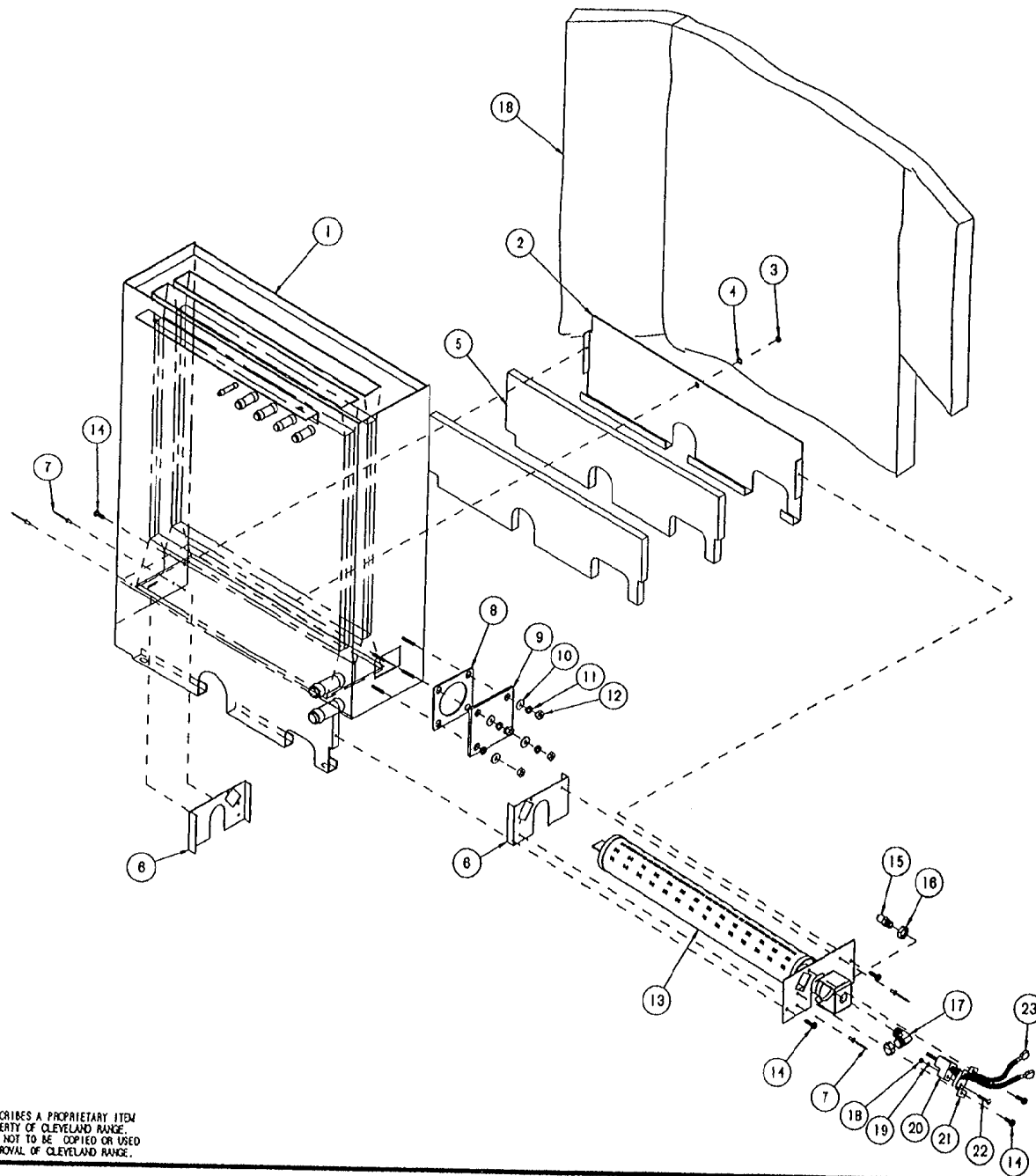

REF.

NO.	QTY.	PART NO.	DESCRIPTION
24	1	108408	INSULATION, GENERATOR WRAP
23	2	20351	TERMINAL, SLIPON, FULL-INSULATED
22	1	19294	SCREW, ROUND HEAD 10-24 X 3/4
21	1	108597	BRACKET, IGNITOR MOUNT
20	1	108595	PROBE, HOT SURFACE, MORTON 401 P
19	1	101337	WASHER, INT. TOOTH LOCK, #8
18	1	14859	NUT, HEX 10-24, S/S
17	-	108459	FITTING, COMP. 1/2 T X 1/4 IPT, 90°, MODIFIED
16	-	108460	NUT, 1/4 NPT, BRASS
15	-	1084021	ORIFACE, #41 DRILL, LP GAS
15	-	108402	ORIFACE, #21 DRILL, NATURAL GAS
14	5	108123	SCREW, TORX SLOT, #10 X 1/2
13	1	108582	BURNER, WELD ASSEMBLY
12	4	14818	NUT, HEX, 1/4-20
11	4	23105	WASHER, LOCK, 1/4" S/S
10	4	23116	WASHER, FLAT, 1/4" X 5/8"
9	1	18548	COVER, BLOCK-OFF
8	1	07128	HEATER GASKET
7	4	18358	RIVET, 1/8 DIA. FLUSH BREAK S/S
6	2	108382	BRACKET, SIDE, INSULATION SUPPORT
5	2	108380	INSULATION, CUT, COMBUSTION CHAMBER
4	1	23114	WASHER, LOCK, INT. TOOTH, #10-32
3	1	14845	NUT, HEX #10-32 ZINC PLATED
2	1	108381	BRACKET, REAR, INSULATION SUPPORT
1	1	108389	GENERATOR ASSY, WELD, SC5.1 GAS

Cleveland Range Inc.
 1333 East 179th St. Cleveland, Ohio 44110-2574

DECIMAL ± N/A	SCALE 1/4=1	DRAWN BY DUTCHMAN	APPROVED BY J. B.
ASSEMBLER ± N/A	TITLE GENERATOR ASSEMBLY WITH HOT SURFACE PROBE STEAMCRAFT 5.1, GAS		
CK	DATE 07-28-93	DRAWING NO. C-1084072	REV. -

THIS DESIGN DESCRIBES A PROPRIETARY ITEM AND IS THE PROPERTY OF CLEVELAND RANGE. THIS DRAWING IS NOT TO BE COPIED OR USED WITHOUT THE APPROVAL OF CLEVELAND RANGE.

NOTE: ALL DIMENSIONS $\pm .125"$, UNLESS OTHERWISE SPECIFIED.

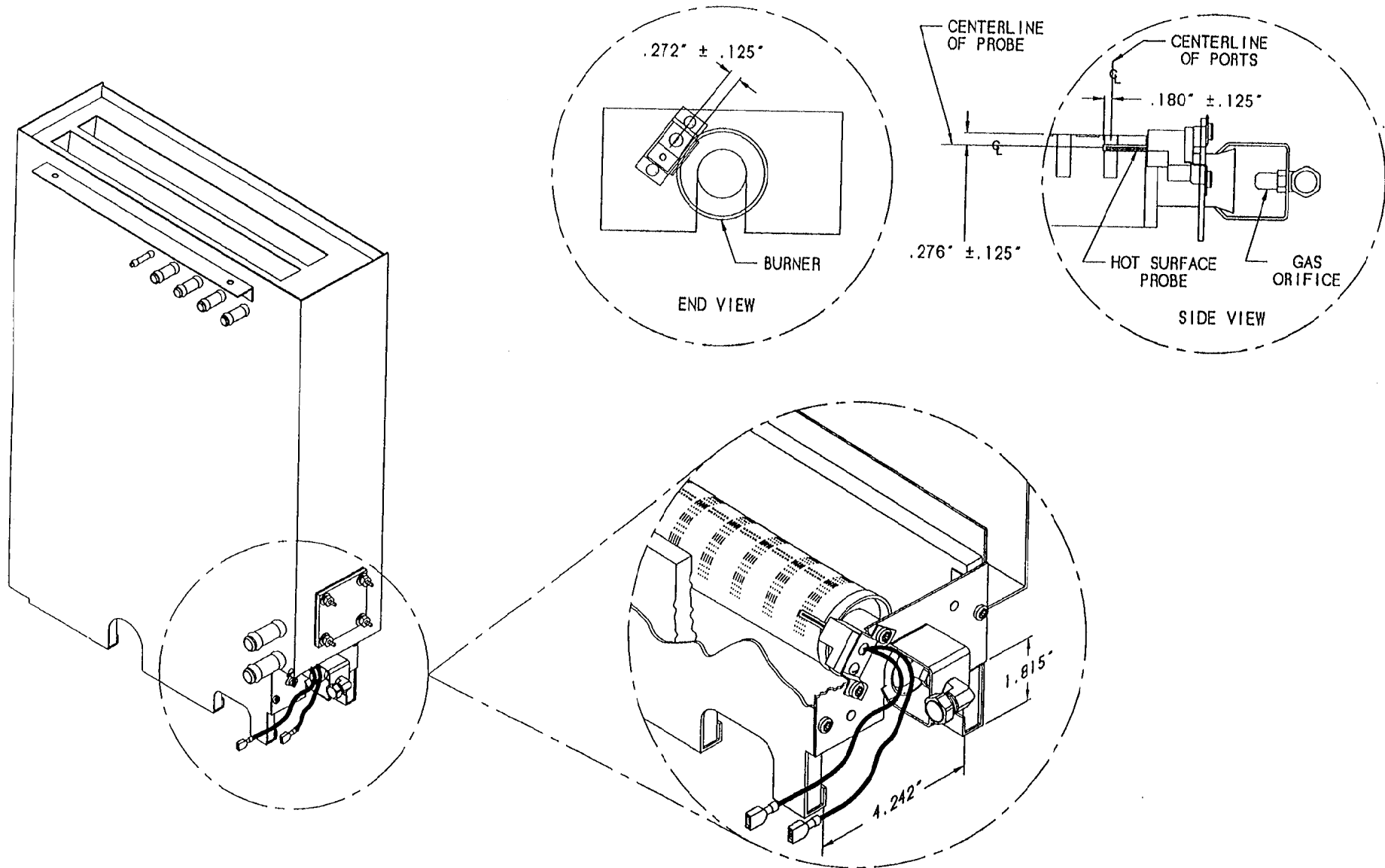

**CLEVELAND RANGE INC. STEAMCRAFT 5.1 GAS
HOT SURFACE PROBE LOCATION, DWG. 106407G1**

LET.	REVISIONS	JATE	BY
------	-----------	------	----

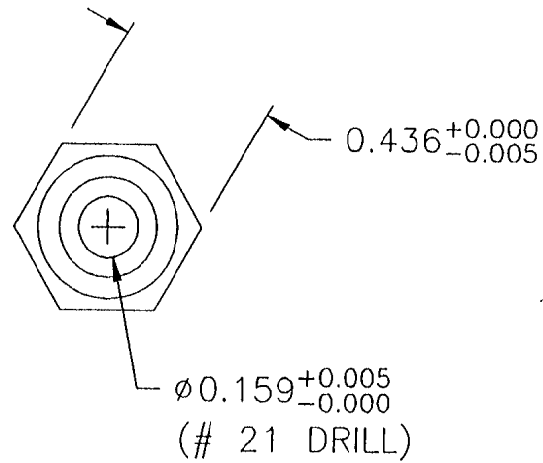
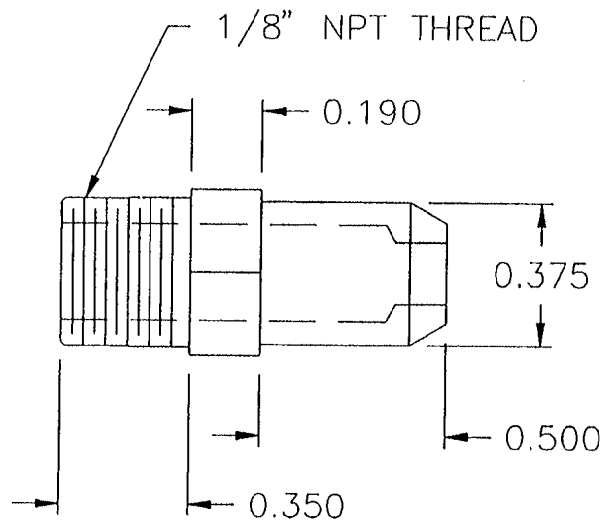

MATERIAL:
BRASS

ITEM	QTY	PART NO.	DESCRIPTION	
TOLERANCES (EXCEPT AS NOTED)	<p>CLEVELAND RANGE INC.</p> <p>1333 East 179th St. Cleveland, Ohio 44110-2574</p>			
DECIMAL ±.030	SCALE 2=1	DRAWN BY JPB	APPROVED BY	
ANGULAR ± 1°	TITLE ORIFICE, GAS, # 21 DRILL NATURAL GAS, S/C 5.1			
AC	DATE 3/23/93	DRAWING NO. A- 106402	REV -	

THIS DESIGN DESCRIBES A PROPRIETARY ITEM AND IS THE PROPERTY OF CLEVELAND RANGE.
THIS DRAWING IS NOT TO BE COPIED OR USED WITHOUT THE APPROVAL OF CLEVELAND RANGE

LET.	REVISIONS	ATE	BY
------	-----------	-----	----

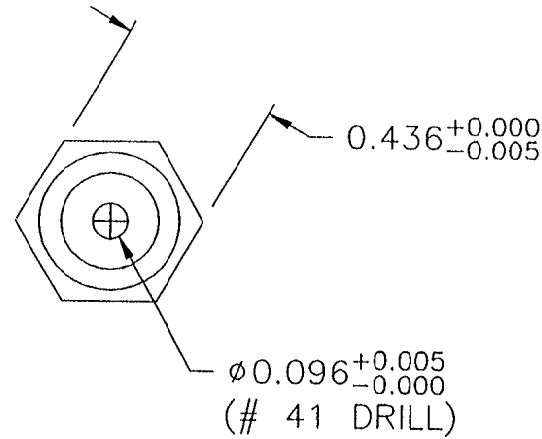
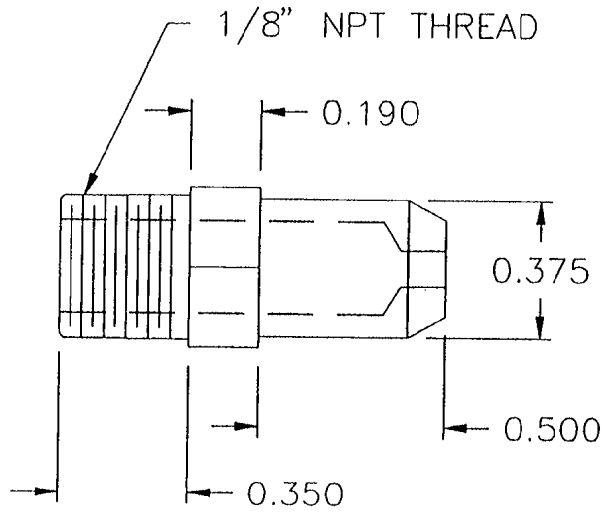

MATERIAL:
BRASS

ITEM	QTY	PART NO.	DESCRIPTION	
TOLERANCES (EXCEPT AS NOTED)		CLEVELAND RANGE INC. 1333 East 179th St. Cleveland, Ohio 44110-2574		
DECIMAL ± 0.030	SCALE 2=1	DRAWN BY JPB	APPROVED BY	
ANGULAR $\pm 1^\circ$	TITLE ORIFICE, GAS, # 41 DRILL LP GAS, S/C 5.1			
AC	DATE 3/23/93	DRAWING NO. A- 1064021	REV -	

THIS DESIGN DESCRIBES A PROPRIETARY ITEM AND IS THE PROPERTY OF CLEVELAND RANGE.
THIS DRAWING IS NOT TO BE COPIED OR USED WITHOUT THE APPROVAL OF CLEVELAND RANGE

LET.	REVISIONS	DATE	BY
A	ADDED CONFIGURATION FOR CLEAN LIGHT PER E.O. 10-2812	09-15-94	PJD

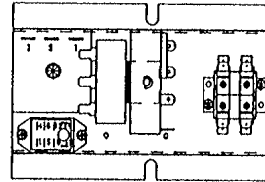
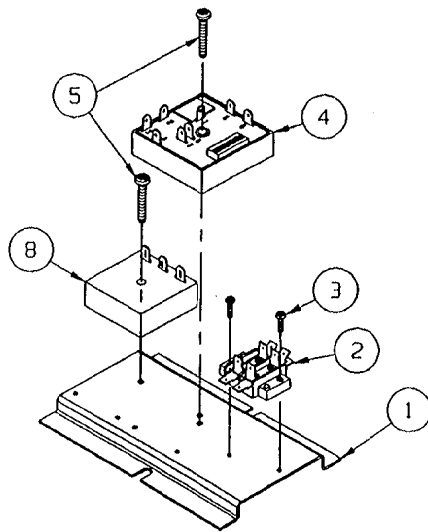
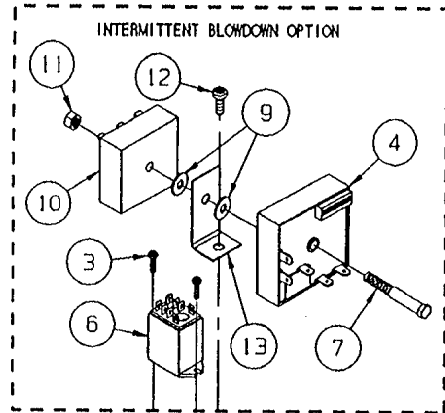

106760

INTERMITTENT BLOWDOWN (OPTIONAL)

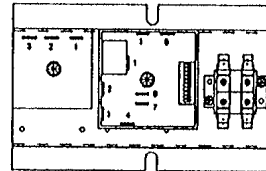
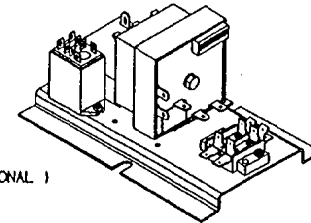

1067601

HEAT STANDBY (STANDARD)

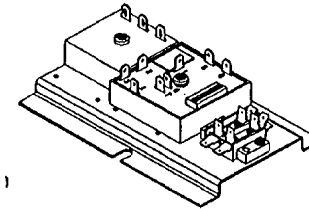

△	13	-	1	105955	BRACKET, DUAL TIMER MOUNTING
△	12	-	1	106123	SCREW, TORX/SLOT #10-32 X .500" LG.
△	11	-	1	14618	NUT, HEX 1/4-20, FULL FINISH
△	10	-	1	106541	TIMER, 1 MIN. ON 0.8 SEC. OFF
△	9	-	2	23116	WASHER, FLAT 1/4-20 S/S
△	8	1	1	106580	TIMER, 20 SEC ON, 6 MIN. OFF
△	7	-	1	106118	BOLT, 1/4-20 X 2-1/4, ZINC PLATED
△	6	-	1	105966	RELAY, 120 V, DPDT
△	5	2	1	106124	SCREW, TORX/SLOT #10-32 X 1.00" LG.
△	4	1	1	106911	TIMER, CLEAN LIGHT (DIP SWITCHES)
△	3	2	4	106127	SCREW, TORX/SLOT #6-32 X .500" LG.
	2	1	1	44168	TERMINAL, BLOCK ASM, 2 POLE
	1	1	1	106306	BRACKET, OPTION PLATE
ITEM	QTY.			PART NO.	DESCRIPTION

1067601 HEAT STANDBY	106760 INT. BLOWDOWN	TOLERANCES (EXCEPT AS NOTED)		CLEVELAND RANGE INC. 1333 East 179th St. Cleveland, Ohio 44110-2574	
DECIMAL ± N/A	SCALE 1/2"=1"	DRAWN BY D. ATHERTON		APPROVED BY	
ANGULAR ± N/A	TITLE HEAT STANDBY PLATE WITH INTERMITTENT BLOWDOWN OPTION STEAMCRAFT ULTRA 5 GAS				
CK	DATE 01/21/94	DRAWING NO. C - 106760/1067601		REV. A	

THIS DESIGN DESCRIBES A PROPRIETARY ITEM AND IS THE PROPERTY OF CLEVELAND RANGE. THIS DRAWING IS NOT TO BE COPIED OR USED WITHOUT THE APPROVAL OF CLEVELAND RANGE.

LET.	REVISIONS	DATE	BY
A	REVISED NOTES PER E.O. 1 R2	04-14-93	PJO
B	REDRAWN & REVISED PER EOC/C-2400 R1	08-17-93	PJO
C	ADDED SC 5.1 GAS TIMER	08-02-93	PJO
D	P/N 106541 WAS 104716	11-04-93	DFA

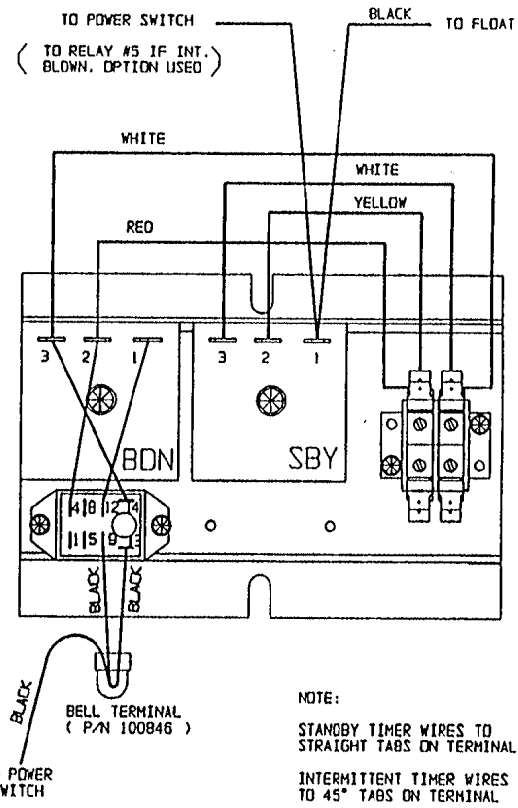
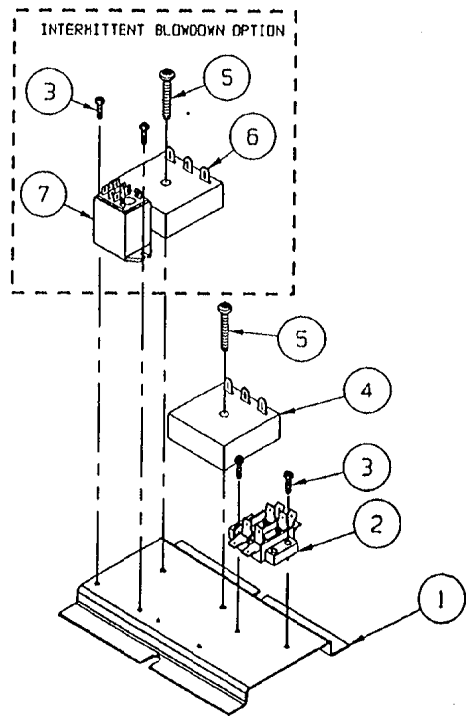

NOTE:
 STANDBY TIMER WIRES TO STRAIGHT TABS ON TERMINAL
 INTERMITTENT TIMER WIRES TO 45° TABS ON TERMINAL

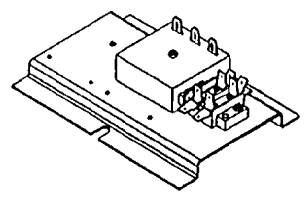

HEAT STANDBY (STANDARD)

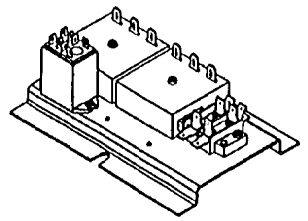

INTERMITTENT BLOWDOWN (OPTIONAL)

ITEM	QTY.	PART NO.	DESCRIPTION
7	1	105966	RELAY, 120 V, DPDT
6	1	106541	TIMER, 1 MIN ON 0.8 SEC OFF
5	2	106124	SCREW, TORX/SLOT 10-32 X 1.00"
4	2	106580	TIMER, 20 SEC ON, 6 MIN. OFF
4	1	108247	TIMER, 2 SEC ON, 64 SEC OFF
3	4	106127	SCREW, TORX/SLOT 6-32 X 1/2"
2	1	44168	TERMINAL, BLOCK ASM, 2 POLE
1	1	106306	BRACKET, OPTION PLATE

DESIGN DESCRIBES A PROPRIETARY ITEM
 IS THE PROPERTY OF CLEVELAND RANGE.
 THIS DRAWING IS NOT TO BE COPIED OR USED
 WITHOUT THE APPROVAL OF CLEVELAND RANGE.

ITEM	QTY.	PART NO.	DESCRIPTION
STEAMCRAFT 3.1	1	105966	RELAY, 120 V, DPDT
STEAMCRAFT 5.1	1	106541	TIMER, 1 MIN ON 0.8 SEC OFF
SC 5.1 GAS	1	106124	SCREW, TORX/SLOT 10-32 X 1.00"

TOLERANCES (EXCEPT AS NOTED)	CLEVELAND RANGE INC. 1333 East 179th St. Cleveland, Ohio 44110-2574		
DECIMAL ± N/A	SCALE 1/2" = 1"	DRAWN BY DUTCHMAN	APPROVED BY
ANGULAR ± N/A	TITLE HEAT STANDBY WITH INTERMITTENT BLOWDOWN STEAMCRAFT 3		
DATE 03-18-93	DRAWING NO. C - 106433	REV. 0	

LET.	REVISIONS	DATE	BY
------	-----------	------	----

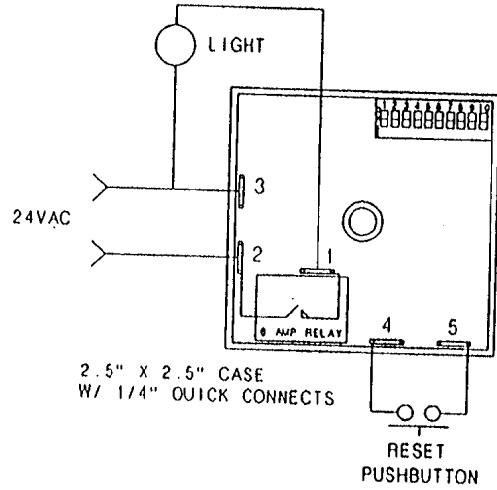

SWITCH #	TIME AMOUNT
1 •	0.5 HR
2 •	1.0 HR
3 •	2.0 HR
4 •	4.0 HR
5 •	8.0 HR
6 •	16.0 HR
7 •	32.0 HR
8 •	64.0 HR
9 •	128.0 HR
10 •	256.0 HR

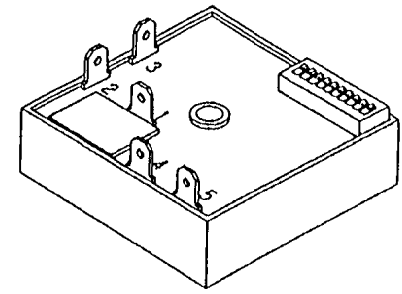

COMBINE SWITCHES FOR TIME DELAY IN HOURS
 EXAMPLES:
 37 HRS • SWITCH 7 + SWITCH 4 + SWITCH 2
 250 HRS • SWITCH 9 + SWITCH 8 + SWITCH 7
 + SWITCH 6 + SWITCH 5 + SWITCH 3

SOURCE:
 AIROTRONICS
 2747 RT. 20 E. BOX 326
 CAZENOVIA, N. Y. 13035

TYPE: CR-2 TGCX03511H5E2
 INPUT: 24 VAC, 6 AMP
 DELAY: 5-511, 5 HR. ON-DLY

OPERATION:
 SELECT DELAY VIA DIP SWITCH. APPLY 24VAC TO THE TIMER.
 AS THE SUPPLY VOLTAGE IS TURNED ON AND OFF TO THE TIMER
 THE TIMER WILL KEEP TRACK OF THE ELAPSED TIME THE
 SUPPLY VOLTAGE IS ON. ONCE THE TIMERS SUPPLY VOLTAGE HAS
 BEEN ON LONGER THAN THE SELECTED DELAY THE RELAY WILL
 TRANSFER. THIS IN TURN WILL TURN ON THE INDICATOR LIGHT.
 ONCE THIS HAS HAPPENED THE RESET BUTTON WILL BECOME
 ACTIVE AND ALLOW THE TIMER TO BE RESET.

THIS DESIGN DESCRIBES A PROPRIETARY ITEM
 AND IS THE PROPERTY OF CLEVELAND RANGE.
 THIS DRAWING IS NOT TO BE COPIED OR USED
 WITHOUT THE APPROVAL OF CLEVELAND RANGE.

ITEM	QTY.	PART NO.	DESCRIPTION	
TOLERANCES (EXCEPT AS NOTED)		CLEVELAND RANGE INC. 1333 East 179th St. Cleveland, Ohio 44110-2574		
DECIMAL ± .030	SCALE 1=1	DRAWN BY DUTCHMAN	APPROVED BY	
ANGULAR ± 1°	TITLE TIMER, CLEAN LIGHT (DIP SWITCHES)			
CK	DATE 05-23-94	DRAWING NO. B - 106911	REV. -	

LET.	REVISIONS	DATE	BY
A	WAS: HIGH LIMIT NOW: FLOAT PER E.O. 1C-2381 R1	03-01-93	PJD
B	20351 BLACK WAS FROM FLOAT ONLY PER EO 1C-2381 R2	04-14-93	PJD

FOR ON/OFF SWITCH
TIMER

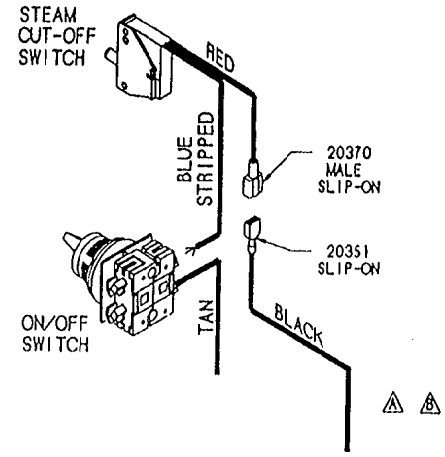

FROM: FLOAT (STANDARD)
GEN. STAND-BY TIMER (SBY OPTION)
BELL TERMINAL (TDS AND SBY OPTIONS TOGETHER)

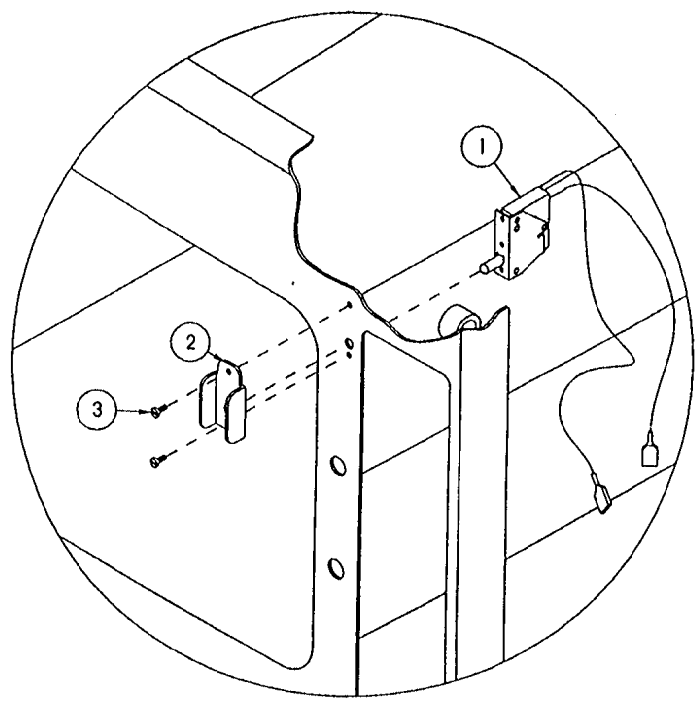

FOR ELECTRICAL & 60 MINUTE
MECHANICAL TIMERS

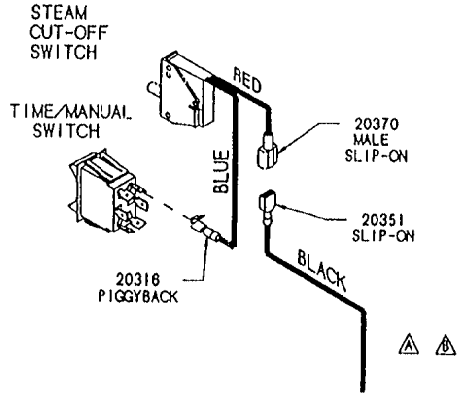

FROM: FLOAT (STANDARD)
GEN. STAND-BY TIMER (SBY OPTION)
BELL TERMINAL (TDS AND SBY OPTIONS TOGETHER)

THIS DESIGN DESCRIBES A PROPRIETARY ITEM
AND IS THE PROPERTY OF CLEVELAND RANGE.
THIS DRAWING IS NOT TO BE COPIED OR USED
WITHOUT THE APPROVAL OF CLEVELAND RANGE.

3	2	105449	SCREW, TRUSS HD. 6-32 X .312, S/S
2	1	105442	GUARD, SWITCH PROTECTION
1	1	104702	SWITCH, CMPT. STEAM SHUT-OFF
ITEM	QTY.	PART NO.	DESCRIPTION
TOLERANCES (EXCEPT AS NOTED)			
CLEVELAND RANGE INC. 1339 East 179th St. Cleveland, Ohio 44110-2574			
DECIMAL ± .030	SCALE N.T.S.	DRAWN BY DUTCHMAN	APPROVED BY
ANGULAR ± 1°	TITLE STEAM CUT-OFF OPTION STEAMCRAFT 3.1 AND 5.1		
CK	DATE 02-03-93	DRAWING NO. C - 106	REV. B

STEAMCRAFT 5.1 GAS w/ MECHANICAL TIMER

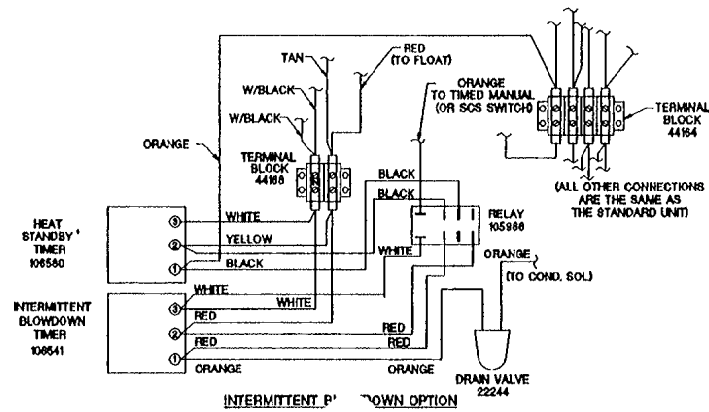
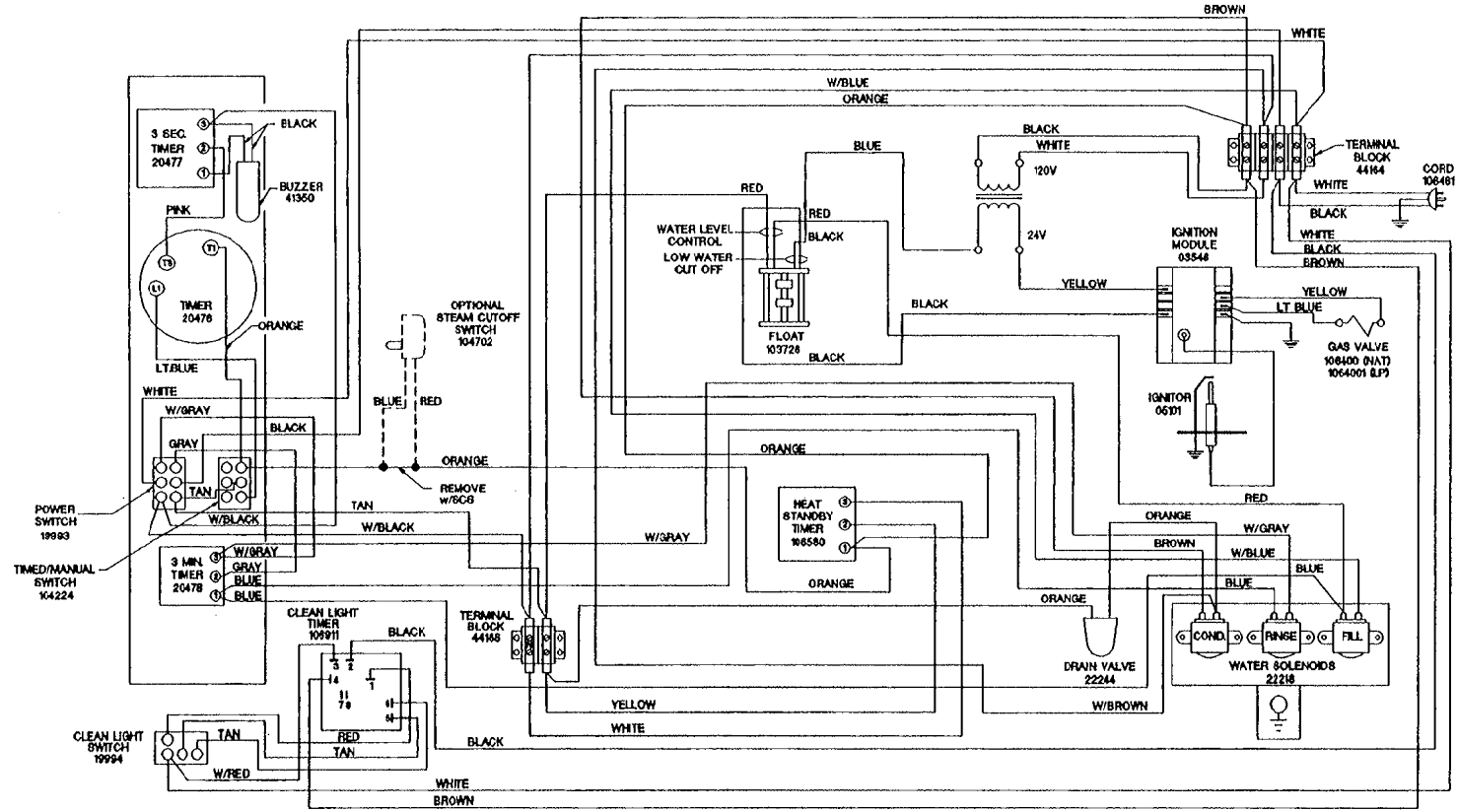

CLEVELAND RANGE 21CGA5
SEQUENCE OF OPERATIONS
STEAMCRAFT ULTRA 5
Mechanical Timer

1. To turn the unit on, depress the red on/off rocker switch.
2. 115 VAC is sent to the red indicator light.
3. 115 VAC is sent to the normally open drain valve closing it.
4. 115 VAC is sent through the normally closed water level (top) float switch to the coil of the R1 relay
 - The R1 relay energizes
 - The R1 contacts close 115 VAC is sent to the fill solenoid
5. The fill solenoid opens and the generator fills through the drain valve.
 - The water fills to the normally open low water cut off float switch (bottom float).
 - The float is lifted by the water and the switch closes.
 - The water fills to the normally closed water level (top) float switch.
 - The float is lifted by the water and the switch opens.
 - With the switch opened 115 VAC is removed from the coil of the R1 relay.
 - The R1 relay deenergizes and 115 VAC is removed from the fill solenoid and the unit stops filling
 - When the water level drops, the operational water float drops closing the switch and energizing the R1 relay
 - The R1 contacts close 115 VAC is sent to the fill solenoid. The unit fills back to the proper level.
6. When the timed/manual switch is in the timed position and time is on the timer
 - 115 VAC is sent from the timer to the R3 relay coil.
 - The R3 relay energizes
 - The R3B contacts close sending 115 VAC to the timer motor
 - The R3A contacts close sending 115 VAC through the optional door switch to the condensate valve and the primary of the 24 VAC ignition transformer.
 - 115 VAC is sent to the #4 terminal on the clean light timer.
 - The clean light timer counts down from the set time (time is set by dip switches on timer)
 - 115 VAC is sent to the amber light in the clean light switch.
 - The light is turned off and the clean light timer is reset by depressing the clean light timer switch.
 - With the sight glass filled the L.W.C.O. float will be raised and the normally open switch is closed.
 - 24 VAC is supplied from the secondary of the transformer through the L.W.C.O. float switch to the ignition module.

- Spark is sent to the igniter.
 - 24 VAC is sent to the gas valve.
 - The gas valve opens to the first stage (.7" W.C. natural gas and 2.25" LP) allowing gas to the burner.
 - 6 to 8 seconds later the valve opens to the second stage (3.5" W.C. natural gas and 10" W.C. LP)
 - When the gas is ignited the ignition module detects at least 1.5 micro-amps DC through the flame and burner ground wire.
 - If the 1.5 micro-amps DC is not detected in 4 seconds the ignition module locks out and has to be reset by removing 24 VAC to the module. This can be done by turning the steamer on and off.
7. With water in the generator and flame heating it, steam is made and directed into the cooking chamber.
8. The steamer will continue to steam until the timer runs down.
- When the timer times down 115 VAC is removed from the R3 relay.
 - The R3 relay de energizes.
 - The R3B contacts open removing 115 VAC from the timer motor
 - The R3A contacts open removing 115 VAC from the heat circuit
 - 115 VAC is sent to the 3 second timer
 - 115 VAC sent to the buzzer for three seconds.
9. The steamer is turned off by depressing the on/off rocker switch.
- 115 VAC is removed from the heat and timer circuits.
 - 115 VAC is removed from the drain valve.
 - 115 VAC is sent to the 3-minute timer and water is sent in to the now open drain valve flushing and cooling the drain.

STEAMCRAFT 5.1 GAS, MECHANICAL TIMER

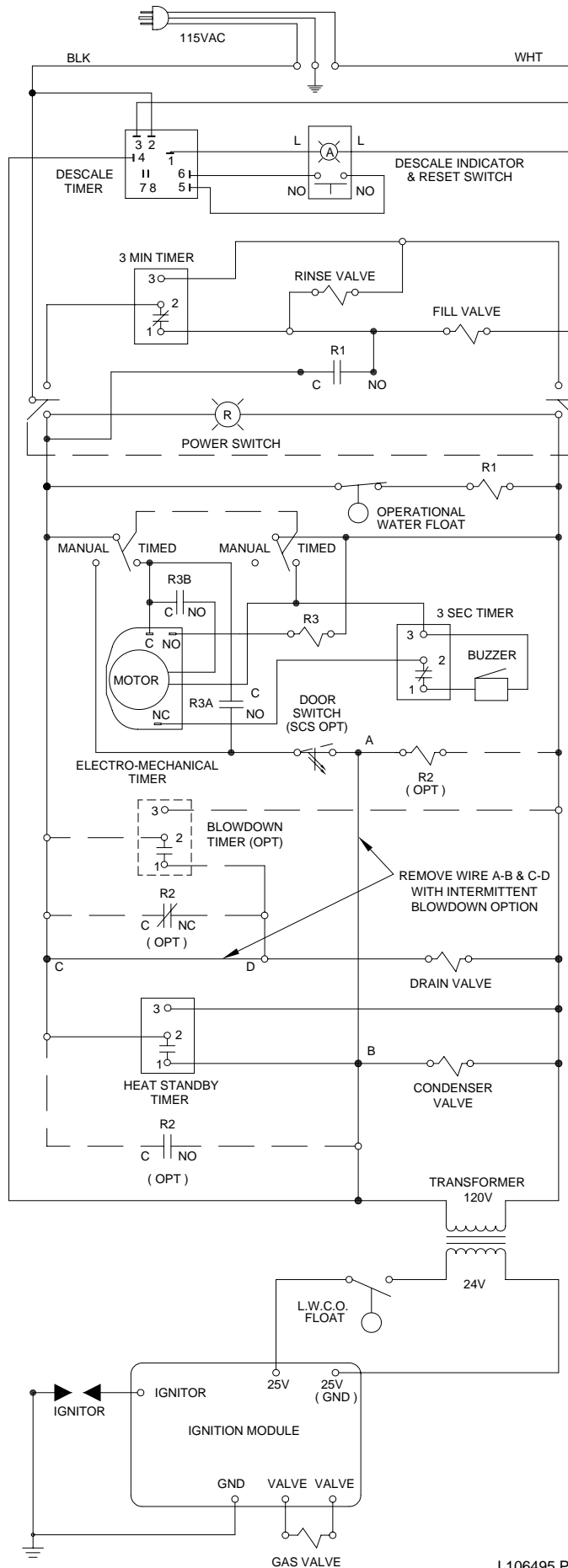

STEAMCRAFT 5.1 GAS w/MECHANICAL TIMER

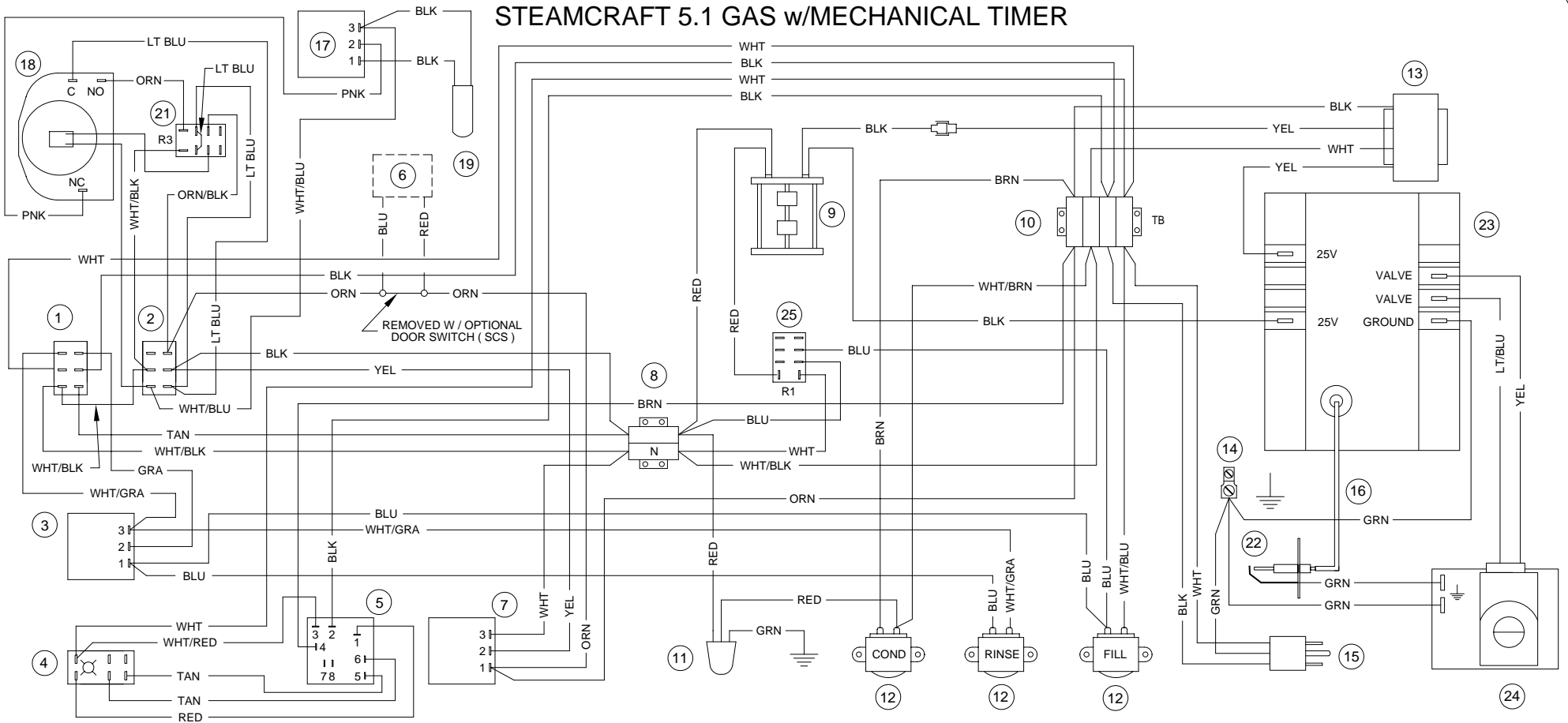

INTERMITTENT BLOWDOWN OPTION

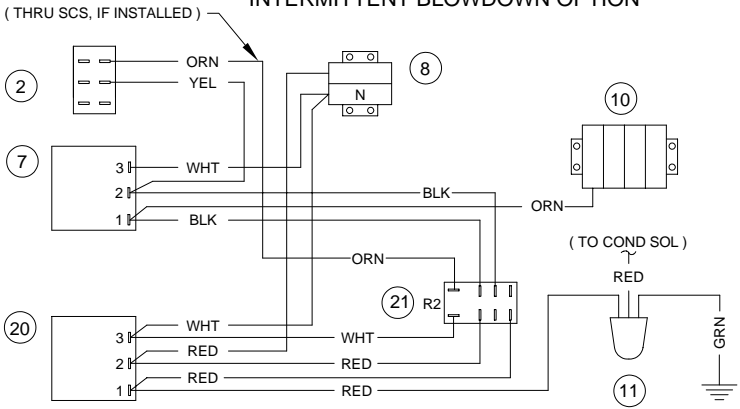

PARTS LIST

- | | | | | | |
|----|------------------------------------|----|--|----|----------------------------|
| 1 | 19993 - POWER SWITCH | 13 | 20528 - TRANSFORMER 24V | 24 | 106400 - GAS VALVE (NAT) |
| 2 | 104224 - TIMED/MANUAL SWITCH | 14 | 20304 - GROUND LUG | | 1064001 - GAS VALVE (LP) |
| 3 | 20478 - 3 MIN TIMER | 15 | 106461 - LINE CORD | 25 | 105966 - RELAY |
| 4 | 19994 - DESCALE INDICATOR RESET SW | 16 | 1065081150 - IGNITION CABLE | | |
| 5 | 106911 - DESCALE TIMER | 17 | 20477 - 3 SEC TIMER | | |
| 6 | 108880 - DOOR SW (SCS) MAGNET | 18 | 110198 - MOTORIZED TIMER | | |
| 7 | 106580 - HEAT STANDBY TIMER | 19 | 41350 - BUZZER | | |
| 8 | 44168 - TERMINAL BLOCK | 20 | 106541 - INTMT BLOWDOWN TIMER | | |
| 9 | 103726 - FLOAT ASSEMBLY | 21 | 105966 - RELAY | | |
| 10 | 44164 - TERMINAL BLOCK | 22 | 300092 - IGNITOR | | |
| 11 | 22221 - DRAIN VALVE | 23 | 03546 - IGNITION MODULE | | |
| 12 | 22218 - WATER SOLENOIDS | | | | |

**CLEVELAND RANGE 21CGA5
SEQUENCE OF OPERATIONS
Electronic Timer
Floats**

1. To turn the unit on, depress the red on/off rocker switch.
2. 115 VAC is sent to the red indicator light.
3. 115 VAC is sent to the 24 VAC timer transformer.
 - 24 VAC is sent to the timer.
4. 115 VAC is sent to normally open drain valve closing it.
5. 115 VAC is sent through the normally closed operational water float switch (top float, red wires) to the fill solenoid.
6. The fill solenoid opens and the generator fills through the drain valve.
 - The water fills to the normally open low water cut off float switch (bottom float black wires).
 - The water lifts the float and the switch closes.
 - The water fills to the normally closed operational water float switch.
 - The water lifts the float and the switch opens.
 - With the switch opened 115 VAC is removed from the fill solenoid and the unit stops filling.
 - When the water level drops, the operational water float drops closing the switch and energizing the fill solenoid. The unit fills back to the proper level.
7. When the timed/manual switch is in the timed position and time is on the timer
 - The timer display will alternate between “PAUS” and the set time. This will continue until the cooking cabinet reaches 193 degrees and the thermal switch closes. Then the timer will begin timing down.
 - 115 VAC is sent from the timer through the optional door switch to the condensate valve and the primary of the 24 VAC ignition transformer.
 - 115 VAC is sent to the #4 terminal on the clean light timer.
 - The clean light timer counts down from the set time (time is set by dip switches on timer)
 - 115 VAC is sent to the amber light in the clean light switch.
 - The light is turned off and timer reset by depressing the clean light timer switch.
 - With the sight glass filled the L.W.C.O. float will be raised and the normally open switch is closed.
 - 24 VAC is supplied from the secondary of the transformer through the L.W.C.O. float switch to the ignition module.
 - Spark is sent to the igniter.
 - 24 VAC is sent to the gas valve.

- The gas valve opens to the first stage (.7" W.C. natural gas and 2.25" LP) allowing gas to the burner.
 - 6 to 8 seconds later the valve opens to the second stage (3.5" W.C. natural gas and 10" W.C. LP)
 - When the gas is ignited the ignition module detects at least 1.5 micro-amps DC through the flame and burner ground wire.
 - If the 1.5 micro-amps DC is not detected in 4 seconds the ignition module locks out and has to be reset by removing 115 VAC to the module.
8. With water in the generator and flame heating it steam is made and directed into the cooking chamber.
9. The steamer will continue to produce steam until the timer counts down.
 - When the timer times down 115 VAC is removed from the heat circuit and condensate circuit.
10. The steamer is turned off by depressing the on/off rocker switch.
 - 115 VAC is removed from the heat and timer circuits.
 - 115 VAC is removed from the drain valve.
 - 115 VAC is sent to the 3-minute timer and water is sent in to the now open drain valve flushing and cooling the drain.

STEAMCRAFT 5.1 GAS, ELECTRONIC TIMER

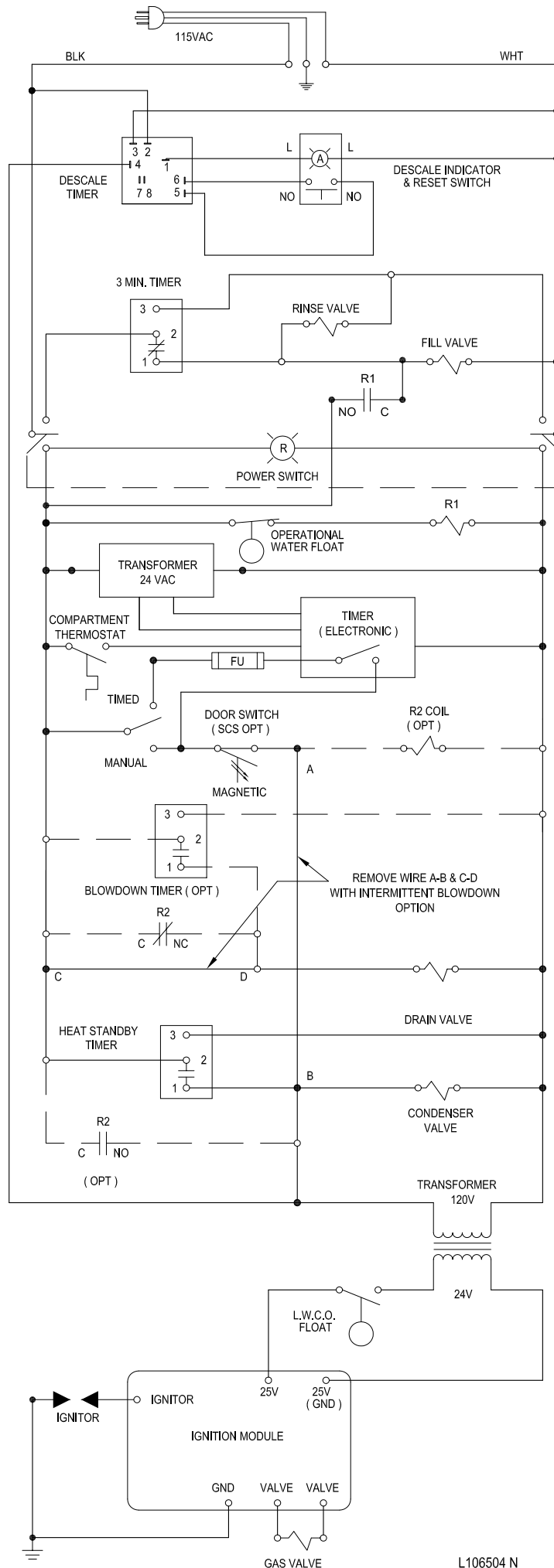

STEAMCRAFT 5.1 GAS w/ELECTRONIC TIMER

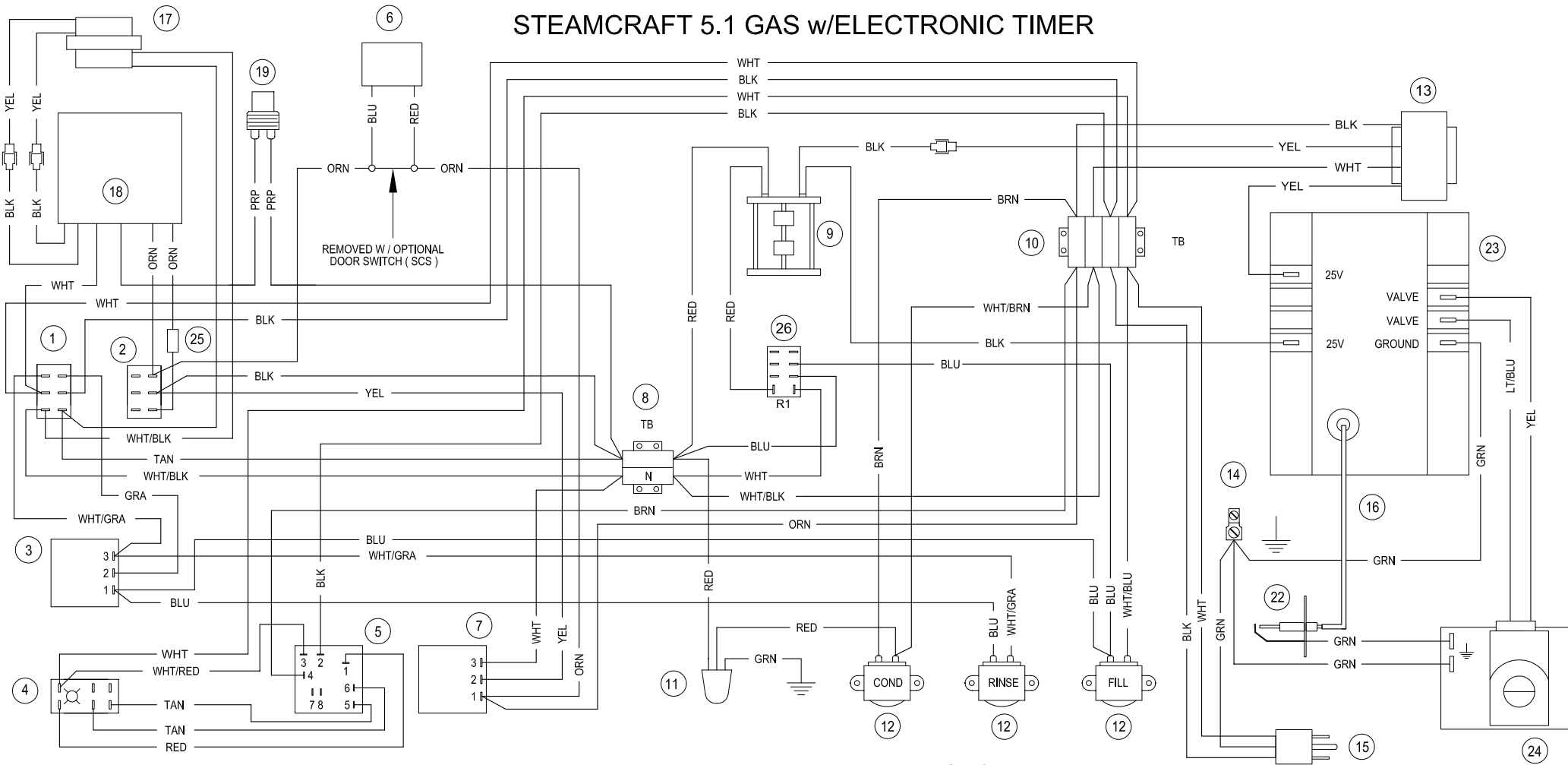

INTERMITTENT BLOWDOWN OPTION

(THRU SCS, IF INSTALLED)

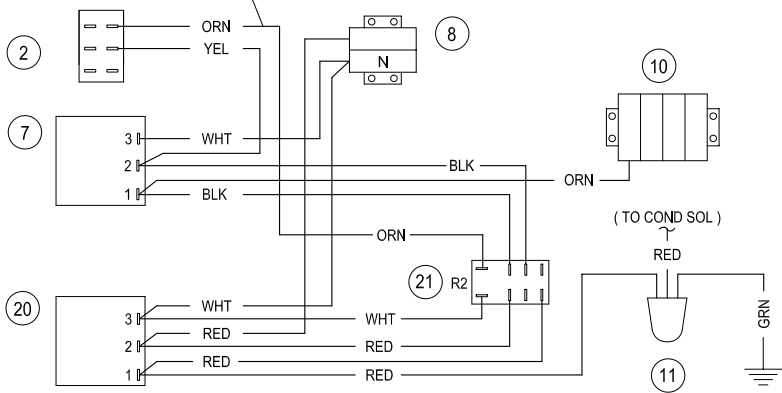

PARTS LIST

- | | | | | | |
|----|------------------------------------|----|-------------------------------|----|----------------------------|
| 1 | 19993 - POWER SWITCH | 12 | 22218 - WATER SOLENOIDS | 23 | 03546 - IGNITION MODULE |
| 2 | 104224 - TIMED / MANUAL SWITCH | 13 | 20528 - TRANSFORMER 24V | 24 | 106400 - GAS VALVE (NAT) |
| 3 | 20478 - 3 MIN TIMER | 14 | 20304 - GROUND LUG | | 1064001 - GAS VALVE (LP) |
| 4 | 19994 - DESCALE INDICATOR RESET SW | 15 | 106461 - LINE CORD | 25 | 106909 - 2 AMP, 250V FUSE |
| 5 | 106911 - DESCALE TIMER | 16 | 1065681-159 - IGNITION CABLE | 26 | 105966 - RELAY |
| 6 | 108880 - DOOR SW (SCS) MAGNETIC | 17 | 104390 - TRANSFORMER | | |
| 7 | 106580 - HEAT STANDBY TIMER | 18 | 104389 - ELECTRONIC TIMER | | |
| 8 | 44168 - TERMINAL BLOCK | 19 | 19972 - THERMAL SWITCH | | |
| 9 | 103726 - FLOAT ASSEMBLY | 20 | 106541 - INTMT BLOWDOWN TIMER | | |
| 10 | 44164 - TERMINAL BLOCK | 21 | 105966 - RELAY | | |
| 11 | 22221 - DRAIN VALVE | 22 | 300092 - IGNITOR | | |

PROBLEM:
21CGA5
Steam
cabinet won't
steam with time on
the timer and time/
manual switch in
the timed position

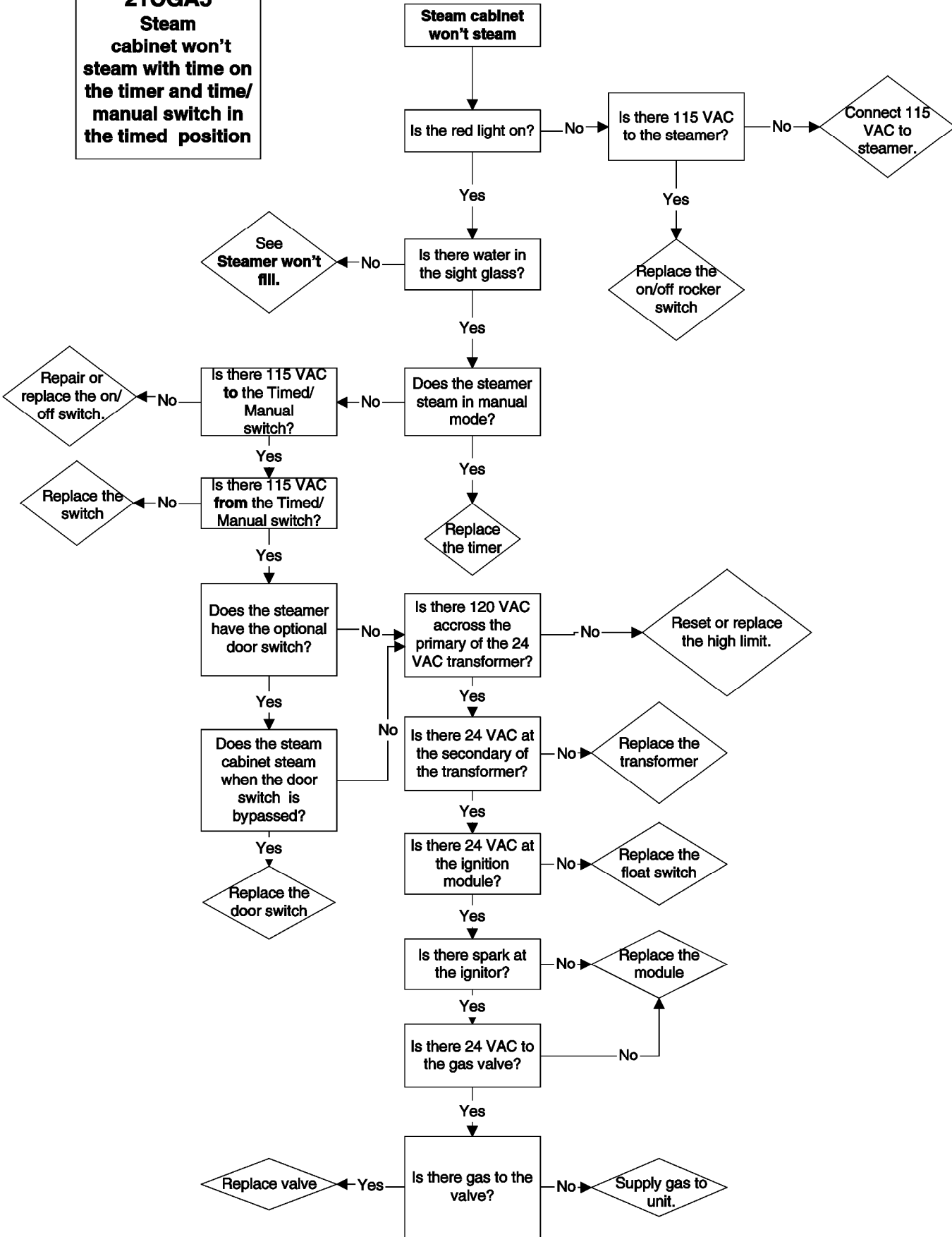

**PROBLEM:
21CGA5
Steam
generator
won't fill**

**Steam generator
won't fill.**

Yes

Is there 115
VAC to the
steamer?

No → Supply 115 VAC to the steamer.

Yes

Is there water
to the
steamer?

No → Supply cold water to the steamer.

Yes

Does steamer fill with
float switch (2 red
wires) by-passed?

Yes → Replace the float switch.

No

Is there
120 VAC across
the coil of the fill
solenoid?

No → Replace the wiring to the fill solenoid.

Yes

Is
water leaving
the fill
solenoid?

No → Replace the fill solenoid

Yes

Is there
120 VAC across
the coil of the drain
valve?

No → Replace wiring to drain solenoid.

Yes

Is water
draining from
the generator?

No → If water is leaving the fill solenoid and not draining from the generator where is it going? check for leaks..

Yes

Replace the drain valve.

Does the steamer have the optional intermittent blowdown timer?

No → Replace the wiring to the intermittent blowdown timer .

Yes

Is there 120 VAC between terminals 2&3 on the timer?

Yes → Replace the intermittent blowdown timer.

Yes

**PROBLEM:
21CGA5
Electronic timer displays "PAUS" and won't count down**

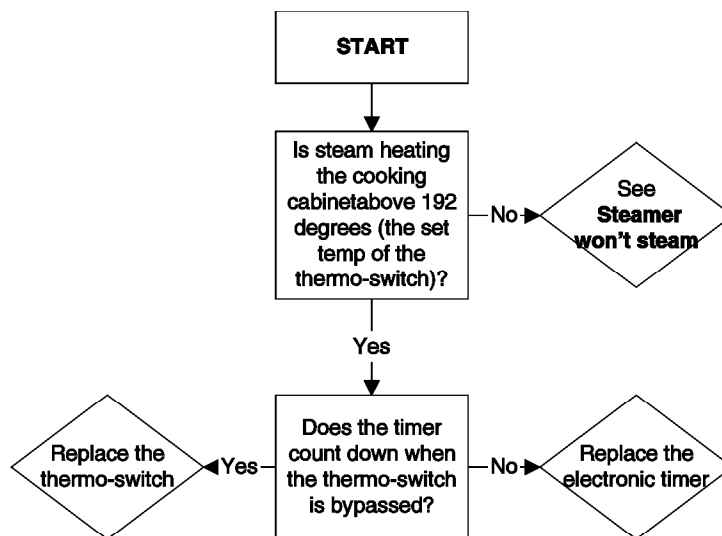

**PROBLEM:
21CGA5
Steam leaks around the door.**

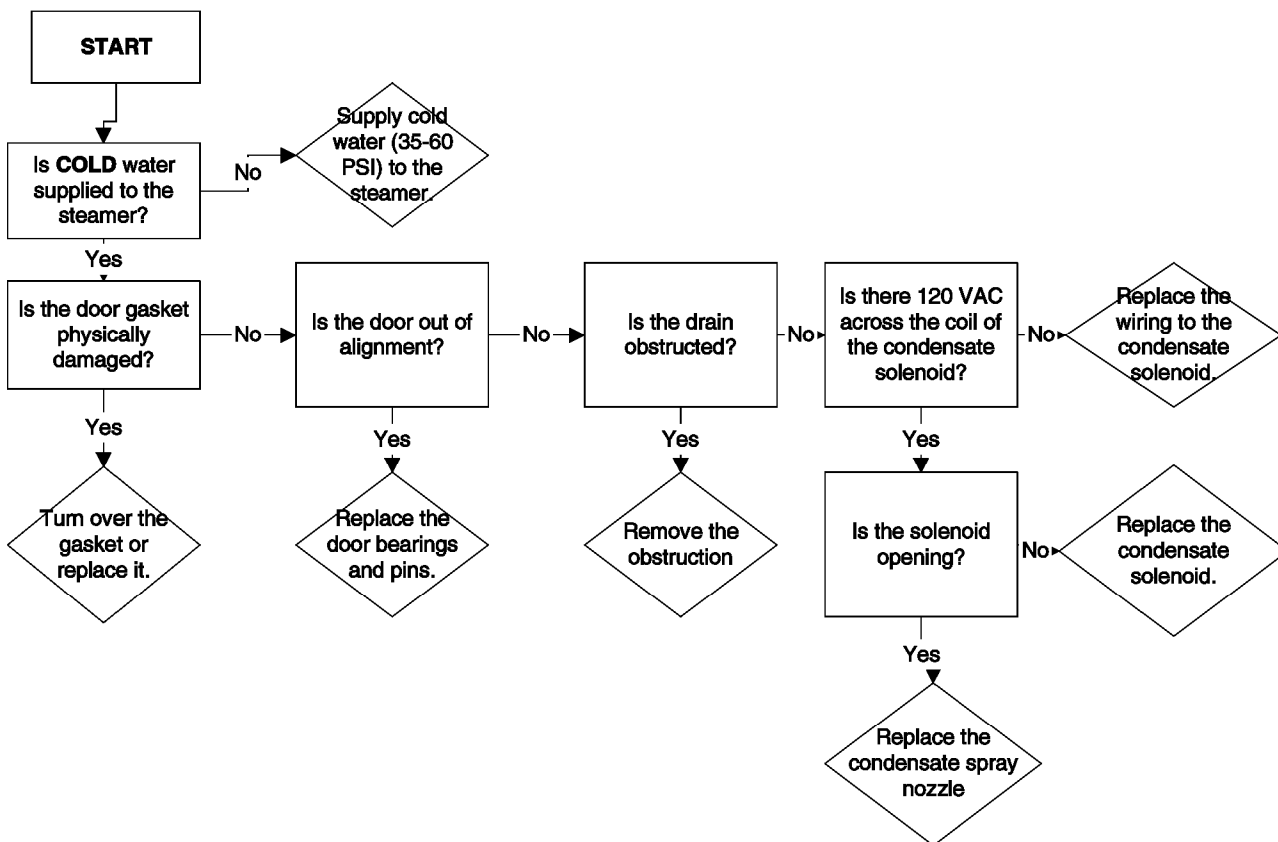

**PROBLEM:
21CGA5
Steamer overfills.
(Water sprays into cooking cabinet)**

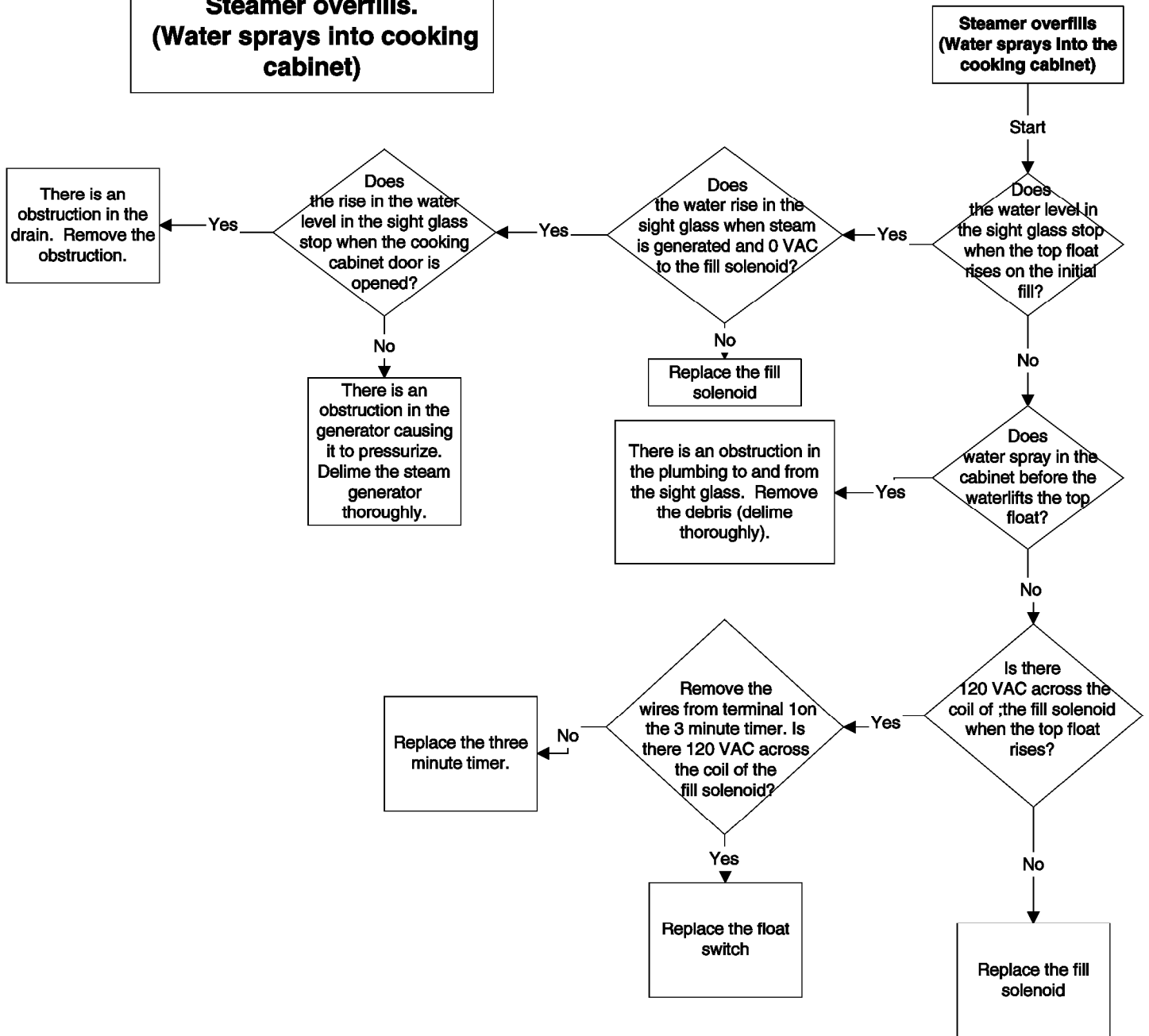

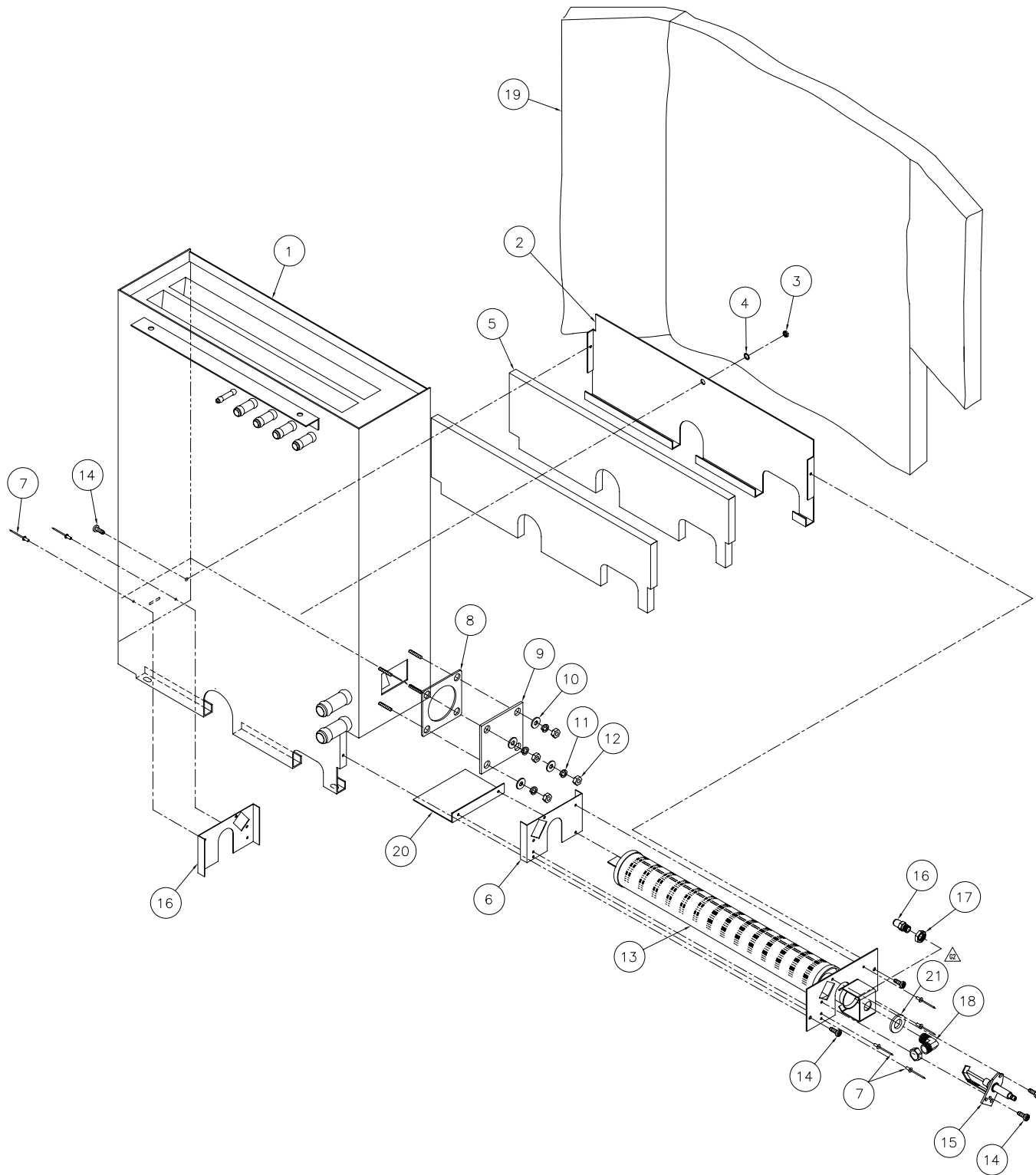

21	-	100539	WASHER, 0.563 ID
20	1	111146	BAFFLE, BURNER, 21CGA5
19	1	106408	INSULATION, GENERATOR WRAP
18	-	106459	FITTING, COMPRESSION, 1/2 T x 1/4-18 NPT, 90°, MOD
17	-	106460	NUT, 1/4-18 NPT, BRASS
16	-	1064021	ORIFICE, #41 DRILL, LP GAS
16	-	106402	ORIFICE, #21 DRILL, NATURAL GAS
15	-	300092	ELECTRODE, REVERSED, COMBINATION IGNITOR/SENSOR
14	5	106126	SCREW, TORX, 8-32 x 1/2
13	-	106582	BURNER, WELD ASSEMBLY
12	4	14618	NUT, HEX, 1/4-20
11	4	23105	WASHER, LOCK, 1/4, SST
10	4	23116	WASHER, FLAT, 1/4 ID x 5/8 OD
9	1	104614	COVER, BLOCK-OFF
8	1	07128	GASKET, HEATER
7	6	18358	RIVET, 1/8 DIA., FLUSH BREAK, SST
6	2	106362	BRACKET, SIDE, INSULATION SUPPORT
5	2	106360	INSULATION, CUT, COMBUSTION CHAMBER
4	1	23114	WASHER, LOCK, INT. TOOTH, #10
3	1	14659	NUT, HEX, 10-24
2	1	106361	BRACKET, REAR, INSULATION SUPPORT
1	1	106407	GENERATOR ASSY, WELD, SC 5.1 GAS

NOTE:

1. USE THREAD JOINT COMPOUND AS REQUIRED TO SEAL.

NOTE: 2
TOP SHEATING WITH 0.625 DIA. HOLE WILL NEED TO OPENED TO 0.890 DIA

NOTE: 3
TOP SHEATING WITH 1.375 DIA. HOLE USE ITEMS 14 & 15

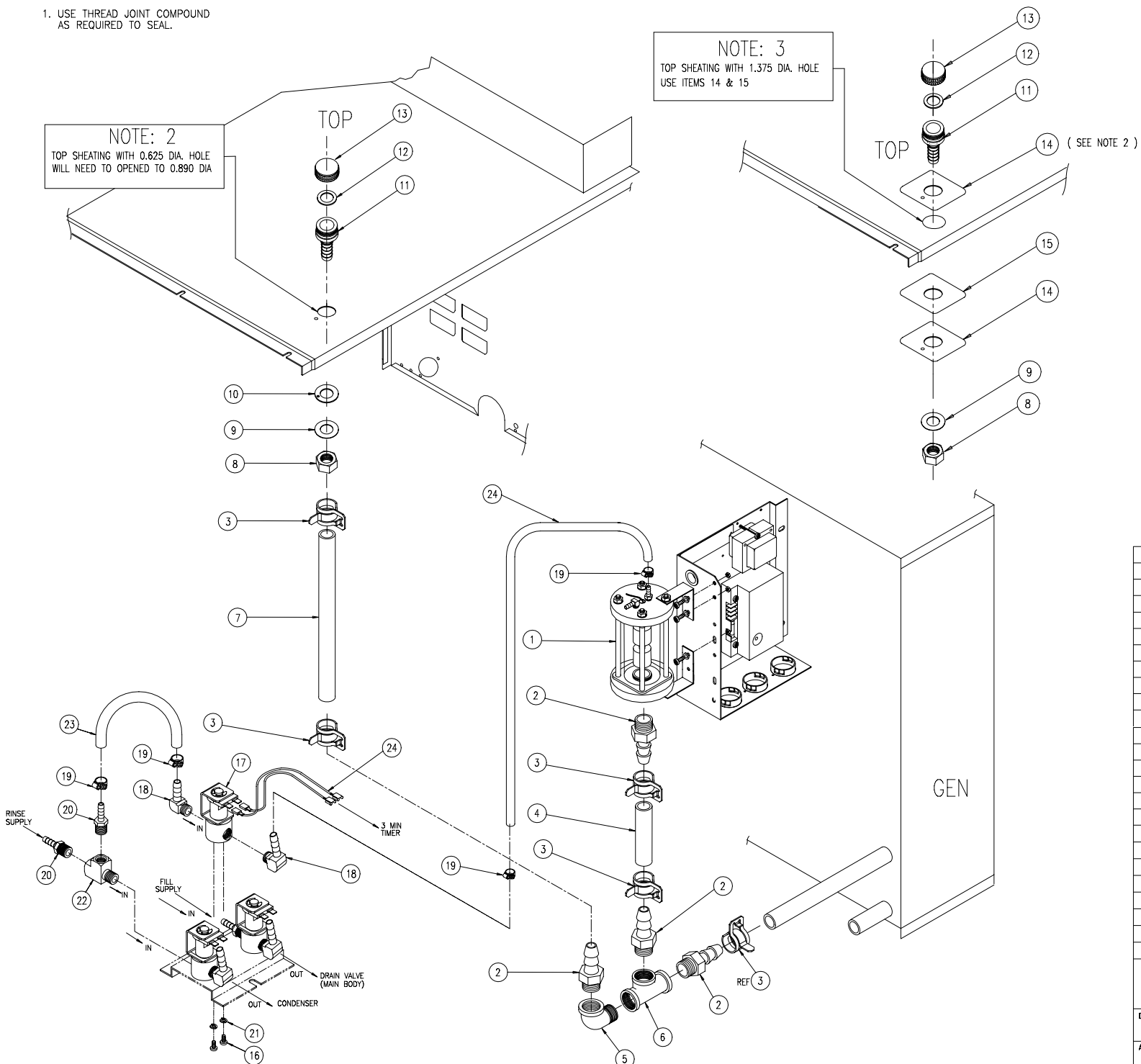

EXPLODED VIEW

KIT P/N 110129

LET.	REVISIONS	DATE	BY
------	-----------	------	----

24	1	300013	HARNES, WIRE, RINSE VALVE
23	1	105850	TUBING, NT-80, 1/4 X 6
22	1	106663	FITTING, MALE RUN, 1/4 MPT X 1/4 FPT
21	2	102641	WASHER, SPLIT LOCK, # 8 SST
20	2	104381	FITTING, HOSE, 1/4 H X 1/4 MPT
19	4	106526	CLAMP, HOSE, 3/8 X 5/8 X 5/16 W
18	2	105786	FITTING, HOSE, 1/4 H X 1/4 MPT, 90°
17	1	22218	SOLENOID VALVE
16	2	19114	SCREW,TRUSS HD,# 8-32 X 0.375
15	2	108723	DESCALER PORT CONVERSION MTC. GASKET
14	2	108724	DESCALER PORT CONVERSION MTC. PLATE
13	1	108031	CAP, HOSE NUT
12	1	108034	WASHER
11	1	109642	FITTING DESCALER
10	1	109646	GASKET
9	1	109645	WASHER
8	1	109644	NUT, HEXJAM
7	1	08511	HOSE, STEAM, WHITE EPDM, FDA 3/4 X 14.000 LG
6	1	20206	TEE, 3/4 , BRASS
5	1	05231	ELL, STREET, 90°, 3/4 BRASS
4	1	08511	HOSE, STEAM, WHITE EPDM, FDA 3/4 X 4.500 LG
3	4	107312	CLAMP, HOSE, METAL TENSION, 1-1/8 OD HOSE
2	4	06240	FITTING, 3/4 H X 3/4 MPT, BRASS
1	1	105877	FLOAT ASSEMBLY, STEAMCRAFT
ITEM	QTY	PART NO.	DESCRIPTION

TOLERANCES (EXCEPT AS NOTED)			
CLEVELAND RANGE INC.			
1333 East 179th St. Cleveland, Ohio 44110-2574			
DECIMAL ± .005	SCALE NA	DRAWN BY VDS	APPROVED BY
ANGULAR ± 1°	TITLE INSTRUCTION, KIT, CONVERT, PROBE TO FLOAT & 3/4 DESCALER S/C 5.1, GAS		
AC	DATE 9-21-00	DRAWING NO. C-260AUC (Sht 1of2)	REV A

THIS DESIGN DESCRIBES A PROPRIETARY ITEM AND IS THE PROPERTY OF CLEVELAND RANGE. THIS DRAWING IS NOT TO BE COPIED OR USED WITHOUT THE APPROVAL OF CLEVELAND RANGE



Cleveland

Descaling Procedure-SteamCraft Ultra and Gemini Series

How Much DISSOLVE to Use

Model	Dissolve
Ultra 3	1/2 Gallon
Ultra 5	1 Gallon
Ultra 10 (Elec.)	1 Gallon (ea.)
Ultra 10 (Gas)	1½ Gallon
Gemini 6 & 10	1 Gallon (ea.)

1. Turn the unit OFF and open the doors:

This will drain and rinse the generator for about 3 minutes.

2. Turn the unit power back On:

The generator will begin to refill with water.

3. Select Timed with the Timed/Manual switch:

DO NOT start the timer, since you do not want to heat the water during descaling. Leave the doors open.

4. Remove descaling port cap and add with the specified amount of DISSOLVE: (See chart above)

Do this while the unit is refilling. The generators can take-up to 8 minutes to refill.

5. After refill has stopped, add extra tap water into the descaling port until liquid is seen entering the cooking cabinet. Note: Ultra 10 gas will have liquid coming out of the drain,

Adding extra water when descaling will raise the descaling solution higher than the normal fill level, allowing the DISSOLVE to work on sensors and surfaces above the water line

Note: Some SteamCraft Ultra models (the electric powered Ultra 10 and Gemini 6 and 10, for example) have two generators and two descaling ports. Both units should be descaled at the same time, using this procedure

6. Let the descaler soak in generator for approximately one hour:

7. After one hour, turn the unit power Off: This will drain and rinse the generator for about 3 minutes.



8. After the 3-minute drain cycle completes, turn the unit back ON. After the filling has stopped, add water until liquid enters the cooking compartment (or drain for the ultra 10 gas), and then turn the unit OFF. This will drain and flush any residue from the water level control assembly. Replace descaling cap.

9. After the 3 minute drain cycle completes, Turn the unit ON and set the Timer for 20 minutes: Make sure the Time/Manual switch is in the timed setting and the doors are closed.

10. When the timer times out (after 20 minutes) turn the power Off:

This will drain and rinse the generator for about 3 minutes.

This ends the descaling procedure. You can now turn the unit back on and resume normal startup and cooking operations.