

# Parts Manual

## Counter Type Electric Convection Steamer



**Series: SteamCraft Models 21CET8**

1333 East 179<sup>th</sup> Street  
Cleveland, Ohio 44110

Phone: (216) 481-4900  
1-800-338-2204

Fax: (216) 481-3782  
[www.clevelandrange.com](http://www.clevelandrange.com)

 Cleveland

NOTES:

- 1.1 SEE INSTRUCTION FOR LABEL LOC. 5 101219
- 2.1 SEE INSTRUCTION DRAWING 1063571 FOR HOSE LOCATIONS.
- 3.1 REVISION SYMBOLS (A) ARE PLACED NEXT TO AFFECTED ITEM NO. IN BILL OF MATERIALS ONLY.
- 4.1 FOR STEAM SHUT-OFF SWITCH OPTION SEE DRAWING 106588 FOR LOCATION OF HOLES IN FACEPLATE AND DRAWING 106355 FOR PICTORIAL WIRING INFO.

**Stacking Blower Retro Kit 110060**

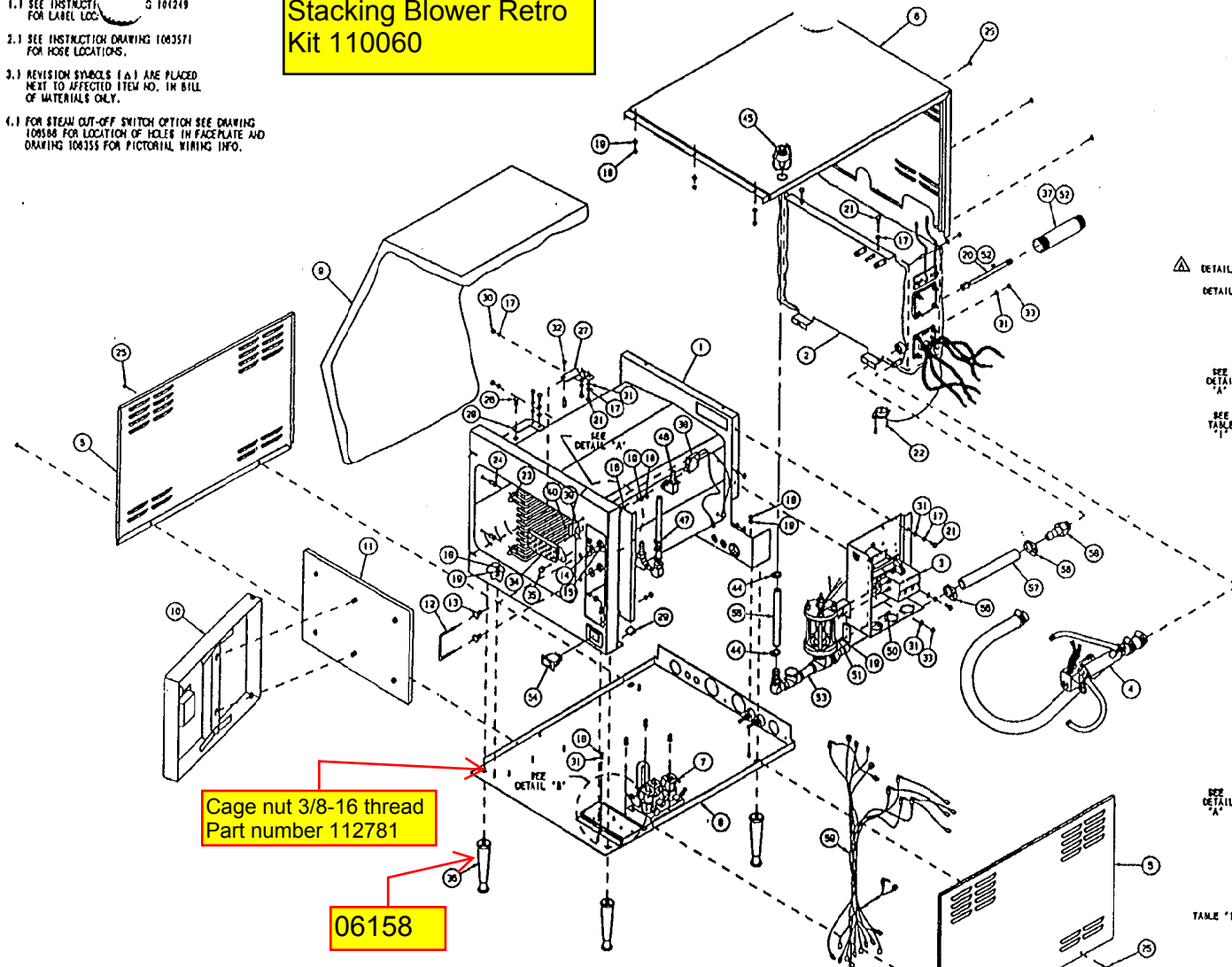

Cage nut 3/8-16 thread  
Part number 112781

06158

TABLE '1'  
STEAM SHUT-OFF OPTION

105419 SCREW	10	2
105412 GUARD	30	1
104194 SWITCH	30	1
104101 DOOR-IN	11	1
1065781 DOOR-OUT	10	1

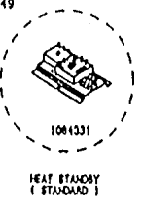
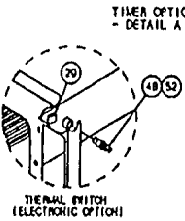

LET.	REVISIONS	DATE	BY
A	UPDATED PER VARIOUS E.O. - SEE E.O. 10-2732	10-06-91	PJO

ITEM	QTY.	PART NO.	DESCRIPTION
59	-	106359	WIRE HARNESS, MECHANICAL, SC 3/5
	-	106358	WIRE HARNESS, ELECTRONIC, SC 3/5
59	1	06210	FITTING, 3/4 H X 3/4 MPT
57	1	1060931004	HOSE, SILICONE 3/4 ID X 1 CD X 10 LG
58	2	105847	CLAMP, PLASTIC 1-1/8 HOSE
55	1	1044880700	HOSE, SILICONE 1/2 ID X 3/4 CD X 7 LG
54	1	19994	SWITCH, ROCKER, 6PST (CLEAN LIGHT)
53	1	106227	FLOAT AND DESCALER ASSY., SC 3.1
52	A/A	00934	SEALANT, RECTORSEAL
51	3	14892	NUT, HEX LOCK ELASTIC 10-24
50	3	19287	SCREW, PAN HEAD 10-24 X 1/2, S/S
DETAIL 'B'	-	106431	HEAT STANDBY PLATE
DETAIL 'A'	-	106433	INT. BLOWDOWN/HEAT STANDBY PLATE
48	-	19972	THERMAL SWITCH
47	1	1070591	BREATHER/SPRAY NOZZLE ASSY.
46	1	1062301	SPRAY NOZZLE ASSY.
45	1	106428	PORV ASSEMBLY, DESCALER
44	1	105878	CLAMP, PLASTIC, 3/4" O.D. HOSE
43	-	23134	WASHER, FLAT, 5/16
42	-	23120	WASHER, FLAT, 3/8 X 7/8
41	-	104409	CLOSURE, THERMAL OPENING
40	-	105419	SCREW, TRUSS HD. 6-32 X .312, S/S
39	-	105472	GUARD, SWITCH PROTECTION
38	-	104198	SWITCH ASSY. CMT. STEAM SHUT-OFF
37	1	104485	HIPPLE, 1-1/4 X 8-1/2, BLACK
36	4	1014501	LEG, ADJUSTABLE, PLASTIC, 4"
35	1	14877	NUT, ACORN
34	1	88298	SCREEN, COMPARTMENT DRAIN
33	3	14885	NUT, HEX, ELASTIC LOCK, 1/4-20
32	2	104082	RING, SNAP, S/S
31	13	23118	WASHER, FLAT, 1/4 X 5/8, S/S
30	9	14818	NUT, HEX 1/4-20, S/S
29	2	234321	D-CLIP, SMALL
28	1	1040732	HINGE ASSY, WELD, UPPER
27	1	1040731	HINGE ASSY, WELD, BOTTOM
26	2	104077	PIN, HINGE
25	7	104080	SCREW, TRUSS HD. SHY. DET., #8 X 1/2
24	8	101305	PIN, RACK
23	2	41423	RACK, PAN SLIDE, 20"
22	2	106127	SCREW, TORX 18 X 1/2, SELF-TAPPING
21	8	10170	SCREW, HEX HEAD 1/4-20 X .625, S/S
20	1	104840	NOZZLE, ASSEMBLY
19	12	101855	WASHER, FLAT #10, S/S
18	11	14872	NUT, HEX LOCK 10-32
17	17	23105	WASHER, LOCK, 1/4" RAYLINK, S/S
16	-	106304	PANEL, CONTROL ASSY, ON/OFF
	-	104088	PANEL, CONTROL ASSY, MECHANICAL
	-	104183	PANEL, CONTROL ASSY, ELECTRONIC
15	2	14878	NUT, LOCK 1/2-13 PREVAILING TORQUE
14	2	23149	WASHER-RYCON, TYPE 6/8
13	2	14895	NUT, DOOR CATCH MOUNTING, S/S
12	1	104048	CATCH, DOOR
11	1	104101	DOOR ASSY, INNER, H.L.
10	-	106353	DOOR ASSY, H.L., W/LOGO, W/ACTUATOR
	-	106375	DOOR ASSY, H.L., W/LOGO
9	1	104081	INSULATION, CUT, SC 3.1
8	1	104096	BASE, WELD ASSEMBLY, SC 3.1/ SC 3.1
7	1	106522	VALVE ASSEMBLY, WATER TRLEY
6	1	103942	SHEETING, TOP/BACK, SC3.1 H.L.
5	2	103966	SHEETING, SIDE, SC3.1
4	1	106524	VALVE ASSEMBLY, DRAIN, SC 3.1 & 5.1
3	1	104093	COMPONENT PANEL ASSY, SC3.1 H.L.
2	1	104090	GENERATOR ASSEMBLY, SC3.1 H.L.
1	1	104095	CAVITY, WELD ASSY, SC3.1 H.L.

TOLERANCES (UNLESS AS NOTED)			
DECIMAL	SCALE	DRAWN BY	
± N/A	1/8"	DUTCHMAN	
ANGULAR	TITLE		APPROVED BY
± N/A	STEAMCRAFT ULTRA 3, ELECTRIC, H.L. FINAL ASSEMBLY, ALL OPTIONS		
CK	DATE	DRAWING NO.	REV.
	04-15-93	C - 106385	A

THIS DESIGN DESCRIBES A PROPRIETARY ITEM AND IS THE PROPERTY OF CLEVELAND RANGE. THIS DRAWING IS NOT TO BE COPIED OR USED WITHOUT THE APPROVAL OF CLEVELAND RANGE.

NOTES:

1.) SEE INDIVIDUAL ASSEMBLY DRAWINGS 

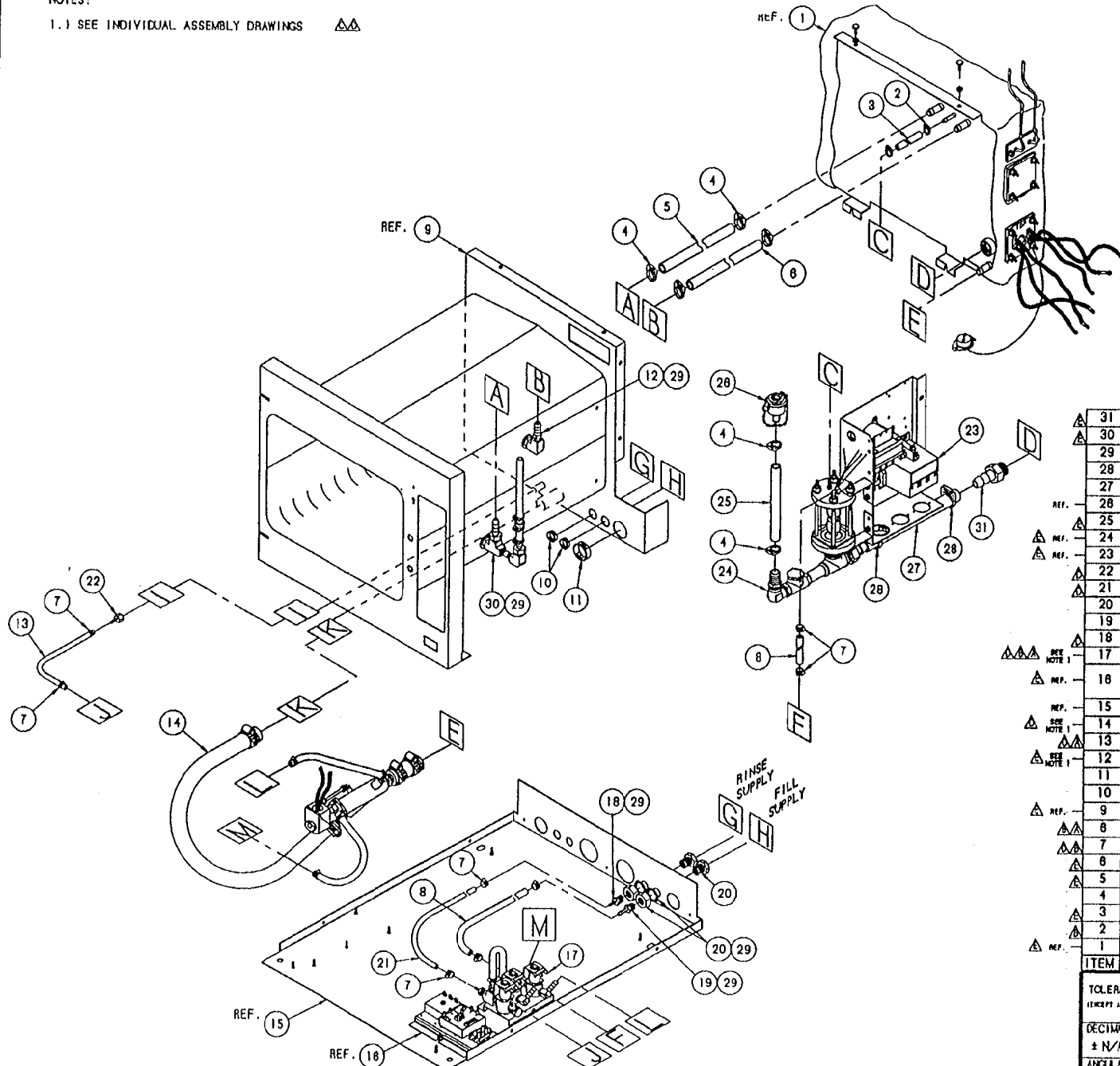

A	1058502100 WAS 9" LG., P/N REVISED, P/N 1058502800 WAS P/N 1058501900 WAS QTY. OF 1, P/N 1058501500 WAS REMOVED PER E.O. KC-2277 R5	WAS J.,	05-18-93	PJD
B	RESTRAINT & BREATHER HOSE ASSY. ADDED AND 104087 VALVE ASSY. REVISED PER E.O. KC-2451 AND KC-2151 R1		06-25-93	PJD
C	ADDED NOTES 3 AND 4 PER E.O. KC-2451 R2		06-29-93	PJD
D	REMOVED RESTRAINT & BREATHER HOSE ASSY AND REMOVED NOTES 2-4 AND ADDED 1/8 ID HOSES & FITTINGS AND 106522 REPLACED 104087 AND 106528 REPLACED 106219 AND 106524 REPLACED 106384 PER EO KC-2492		08-24-93	PJD
E	UPDATED PER VARIOUS E.O.'S - SEE E.O. KC-2732		11-07-94	PJD

△	31	-	06240	FITTING, 3/4 H X 3/4 MPT
△	30	1	1070591	BREATHER/SPRAY NOZZLE ASSEMBLY
	29	A/R	00934	SEALANT, RECTORSAL
	28	2	105847	CLAMP, PLASTIC, 1-1/8 HOSE
	27	1	1080931000	HOSE, SILICONE 3/4 X 1 X 10 LG.
REF.	26	-	106428	PORT ASSY, DESCALER
△	25	1	1044680700	HOSE, SILICONE 1/2 X 3/4 X 7 LG.
△ REF.	24	-	106227	FLOAT/DESCALER ASSY, SC 3.1
△ REF.	23	-	104093	COMPONENT PANEL ASSY, SC 3.1
△	22	1	108862	FITTING, HOSE 1/8 H X 1/8 FPT, STR.
△	21	1	1088642100	HOSE, NT-80, 1/8 X 3/8 X 21' LG.
	20	2	03841	COUPLING, BULKHEAD, 1/4 IPS, BRASS
	19	1	104381	FITTING, HOSE 1/4 H X 1/4 MPT, STR
△	18	1	108861	FITTING, HOSE 1/8 H X 1/4 MPT, BRASS
△△△ REF. NOTE 1	17	1	106522	VALVE ASSEMBLY, WATER INLET, SC 3.1
△ REF.	16	-	1064331	HEAT STANDBY PLATE
	15	-	106433	INT. BLOWDOWN/HEAT STANDBY PLATE
REF.	14	-	104098	BASE, WELD ASSEMBLY
△ REF. NOTE 1	13	1	106524	VALVE ASSEMBLY, DRAIN
△△ REF. NOTE 1	12	1	1068642800	HOSE, NT-80, 1/8 X 3/8 X 26' LG.
△ REF. NOTE 1	11	1	1062901	SPRAY NOZZLE ASSEMBLY, STEAMCRAFT
	10	2	02581	HEYCO BUSHING, INSULATOR, 7/8"
	9	2	02800	HEYCO BUSHING SB-875-11, INSULATOR
△ REF.	8	-	1040951	CAVITY, WELD ASSEMBLY
△△	7	2	1058501900	HOSE, NT-80, 1/4 X 1/2 X 19' LG.
△△	6	8	106528	HOSE CLAMP, METAL, 3/8 X 5/8 X 5/16
△	5	1	1044681250	HOSE, SILICONE, 1/2 X 3/4 X 12-1/2 LG.
△	4	1	1044882250	HOSE, SILICONE, 1/2 X 3/4 X 22-1/2 LG.
△	3	8	105848	HOSE CLAMP, NYLON, 3/4" OD HOSE
△	2	1	1043791800	HOSE, SILICONE, 1/4 X 1/2 X 18 LG.
△	1	3	104383	HOSE CLAMP, NYLON, 1/2" OD HOSE
△ REF.	1	-	104090	GENERATOR ASSEMBLY

ITEM	QTY.	PART NO.	DESCRIPTION
<p>TOLERANCES (UNLESS AS NOTED)</p> <p style="text-align: right;"><b>CLEVELAND RANGE INC.</b> 1333 East 179th St. Cleveland, Ohio 44110-2574</p>			
DECIMAL ± N/A	SCALE 3/16"	DRAWN BY DUTCHMAN	APPROVED BY MLT
ANGULAR ± N/A	TITLE HOSE DETAIL STEAMCRAFT ULTRA 3		
CK	DATE 04-21-93	DRAWING NO. C - 1063571	REV. E

THIS DESIGN DESCRIBES A PROPRIETARY ITEM AND IS THE PROPERTY OF CLEVELAND RANGE. THIS DRAWING IS NOT TO BE COPIED OR USED WITHOUT THE APPROVAL OF CLEVELAND RANGE.

NOTES:

1. SEE WIRING DIAGRAM 104185 FOR WIRE CONNECTION POINTS.

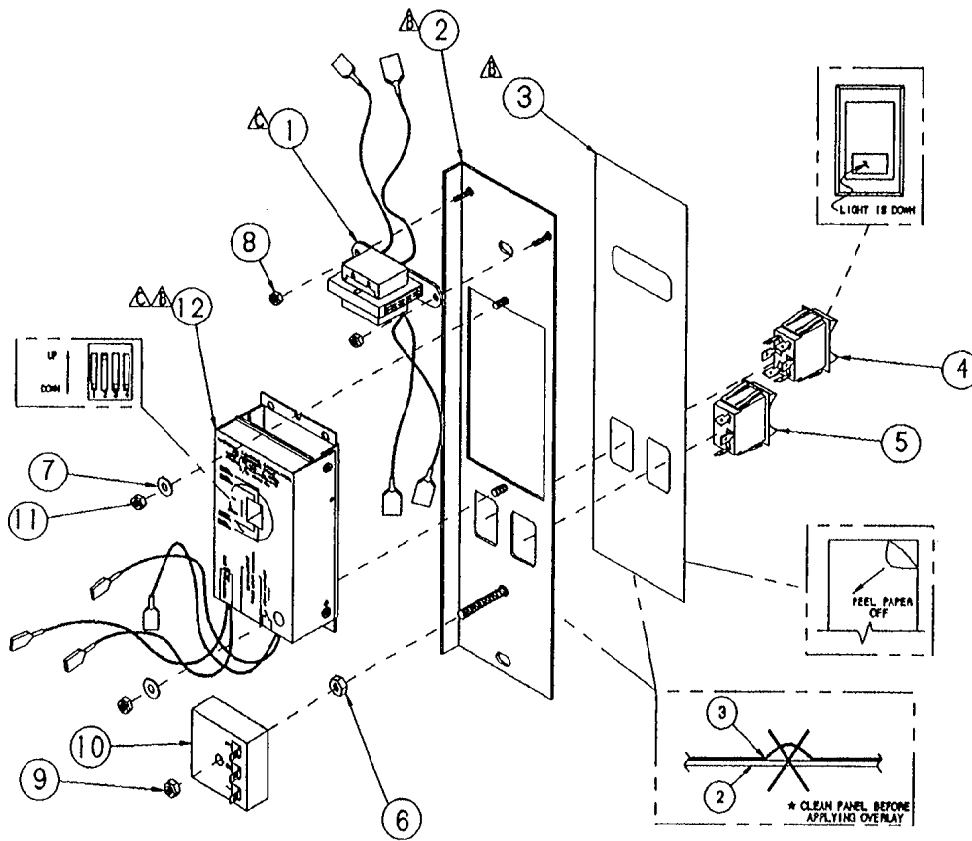

LET.	REVISIONS	DATE	BY
A	ITEM 12 WAS 20478, E.O. C-1781	9-18-90	RJOS
B	ITEM 3 WAS 104052 ITEMS 7 & 8 WERE QTY. OF 4 PICTORIAL CHANGES TO ITEMS 2, 3 & 12 REMOVED RELAY ITEMS - 03524, 03525, 101655, 104223, 1041290200 - E.O. 1876	1-23-91	PJD
C	ADDED TERMINALS TO 104390 ITEM #1 AND 104389 ITEM #12 ITEM 12 WAS 1040071 PANEL, TIMER AND ITEM 1 WAS 1040072 TRANSFORMER - E.O. 1794 R1	5-09-91	PJD
D	P/N 108800 REPLACED P/N 104510 PER E.O. KC-2503	09-21-93	PJD

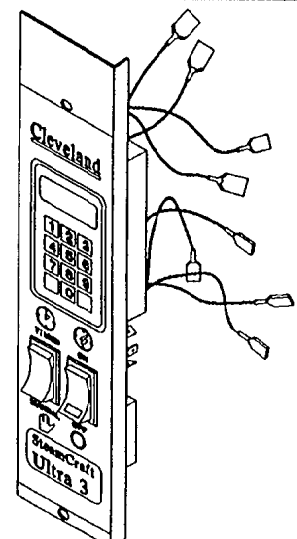

ITEM	QTY.	PART NO.	DESCRIPTION
13	1	104184	HARNES, WIRING, ELECTIC CONTROL (NOT SHOWN)
12	1	104389	TIMER ASSEMBLY, NCC
11	2	14892	NUT, HEX 10-24 ELASTIC LOCK
10	1	20478	TIMER, SOLID STATE, INTERVAL 3 MINUTE
9	1	101873	NUT, HEX 1/4-20 ELASTIC LOCK
8	2	104223	NUT, HEX 8-32 ELASTIC LOCK
7	2	101655	WASHER, FLAT #10 S/S
6	1	14817	NUT, HEX 1/4-20 STEEL
5	1	104224	SWITCH, ROCKER SPDT, MATTE
4	1	19993	SWITCH, ROCKER DPDT, ON/OFF 6A 125V
3	1	108800	LABEL, CONTROL PANEL, ELEC. SC 3.1 ULTRA
2	1	104157	PANEL, WELDMENT
1	1	104390	TRANSFORMER ASSEMBLY

TOLERANCES (EXCEPT AS NOTED)			
<b>CLEVELAND RANGE INC.</b> 1333 East 179th St. Cleveland, Ohio 44110-2574			
DECIMAL ± .030	SCALE 1/2"	DRAWN BY R. RIOS	APPROVED BY
ANGULAR ± 1°	TITLE CONTROL PANEL ASS'Y., ELECTRONIC STEAMCRAFT 3.1 ULTRA		
CK	DATE 09-11-90	DRAWING NO. C - 104163	REV. D

THIS DESIGN DESCRIBES A PROPRIETARY ITEM AND IS THE PROPERTY OF CLEVELAND RANGE. THIS DRAWING IS NOT TO BE COPIED OR USED WITHOUT THE APPROVAL OF CLEVELAND RANGE.

LET.	REVISIONS	DATE	BY
A	REMOVED ITEMS 5, 6, 8 & 9 REVISED ITEM 1 PICTORIAL E.O. 1878 R1 - COST REDUCTION	2-08-91	P.D.
B	SEE E.O. 1 C-1957 R 2	7-31-91	P.D.
C	P/N 20478 ROTATED 90° AND P/N'S 41350 & 14672 MOVED FROM BOTTOM TO TOP OF P/N 104085 PER E.O. 1C-2384 R3	08-25-93	PJD
D	P/N 106802 REPLACED P/N 103721 PER E.O. 1C-2503	09-21-93	PJD

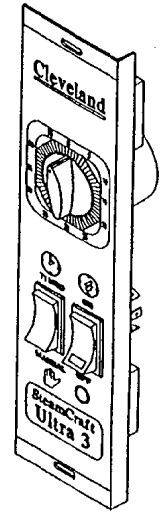
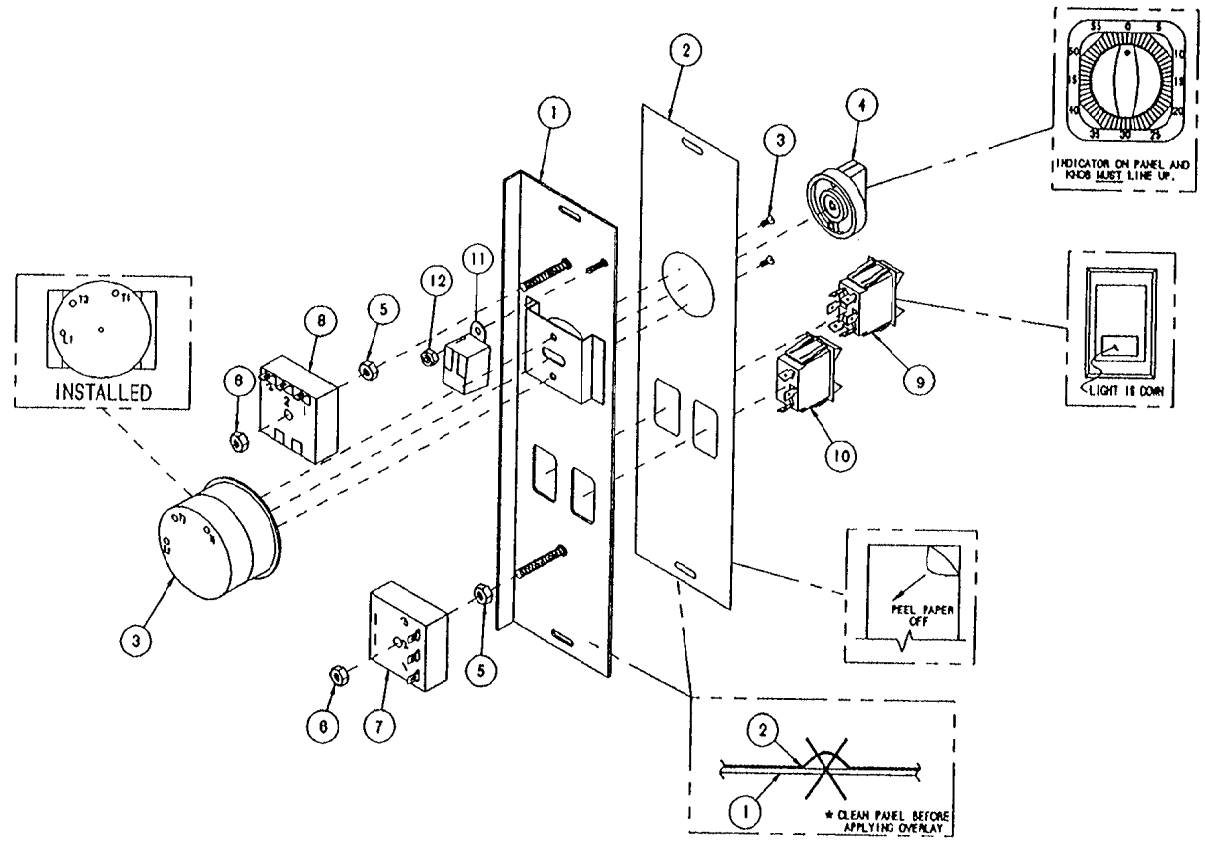

NO.	QTY.	PART NO.	DESCRIPTION
Δ 12	1	14672	#10-32 LOCKING HEX NUT
Δ 11	1	41350	BUZZER
Δ 10	1	104224	MANUAL SWITCH
9	1	19993	POWER SWITCH
Δ 8	1	20478	3-MINUTE TIMER
Δ 7	1	20477	3-SECOND TIMER
6	2	101873	NUT - 1/4-20 ELASTIC LOCK
5	2	14817	BLACK OXIDE 1/4-20 HEX NUT
Δ 4	1	11307	TIMER KNOB
3	1	20476	TIMER WITH MOUNTING SCREWS (2)
Δ 2	1	106602	LABEL, CONTROL, MECH, ULTRA
Δ Δ 1	1	104085	CONTROL PANEL WITH STUDS

TOLERANCES EXCEPT AS SHOWN		CLEVELAND RANGE INC. 1333 East 179th St. Cleveland, Ohio 44110-2574		
DECIMAL ± N/A	SCALE 1=2	DRAWN BY R. RIOS	APPROVED BY J. B.	
ANGULAR ± N/A	TITLE CONTROL PANEL ASS'Y., MECHANICAL STEAMCRAFT 3.1 ULTRA			
CK	DATE 07-9-80	DRAWING NO. C-104086	REV. D	

THIS DESIGN DESCRIBES A PROPRIETARY ITEM AND IS THE PROPERTY OF CLEVELAND RANGE. THIS DRAWING IS NOT TO BE COPIED OR USED WITHOUT THE APPROVAL OF CLEVELAND RANGE.

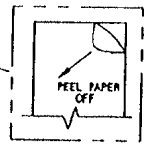
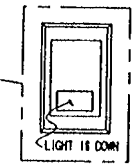
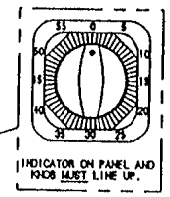
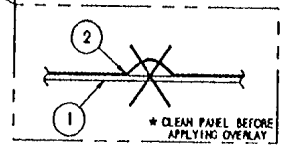

LET.	REVISIONS	DATE	BY
A	HOLES ADDED TO LABEL, P/N 105692 WAS 103719. EO C-2182.	04/06/92	PJD
B	UPDATED PICTORIALY PER E.O. #C-2429 & #C-2495 & #C-2503	09/13/93	NLT

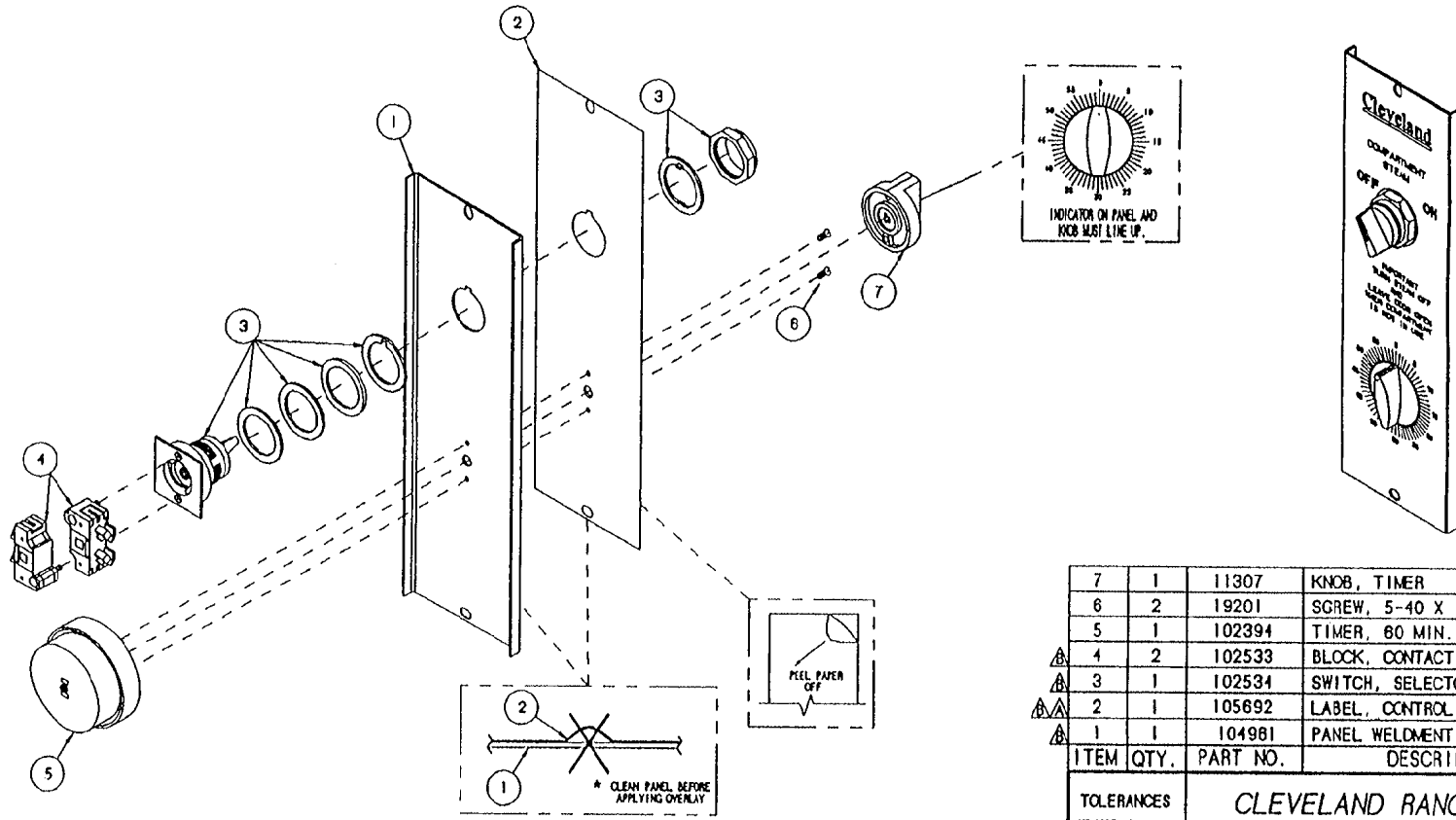

7	1	11307	KNOB, TIMER
6	2	19201	SCREW, 5-40 X .250, PAN HD
5	1	102394	TIMER, 60 MIN., INDICATING
4	2	102533	BLOCK, CONTACT
3	1	102534	SWITCH, SELECTOR
2	1	105692	LABEL, CONTROL PANEL, ON/OFF
1	1	104981	PANEL WELDMENT, ON/OFF CONTROL
ITEM	QTY.	PART NO.	DESCRIPTION

TOLERANCES (EXCEPT AS NOTED)		CLEVELAND RANGE INC. 1333 East 179th St. Cleveland, Ohio 44110-2574	
DECIMAL ± N/A	SCALE 3/8=1	DRAWN BY DUTCHMAN	APPROVED BY BEDFORD
ANGULAR ± N/A	TITLE TIMER ASSEMBLY, ON/OFF CONTROL W/ INDICATING TIMER		
CK	DATE 09-19-91	DRAWING NO. B - 104931	REV. B

THIS DESIGN DESCRIBES A PROPRIETARY ITEM AND IS THE PROPERTY OF CLEVELAND RANGE. THIS DRAWING IS NOT TO BE COPIED OR USED WITHOUT THE APPROVAL OF CLEVELAND RANGE.

LET.	REVISIONS	DATE	BY
A	P/N 106804 REPLACED P/N 108107 PER E.O. #C-2503	09-21-93	PJO

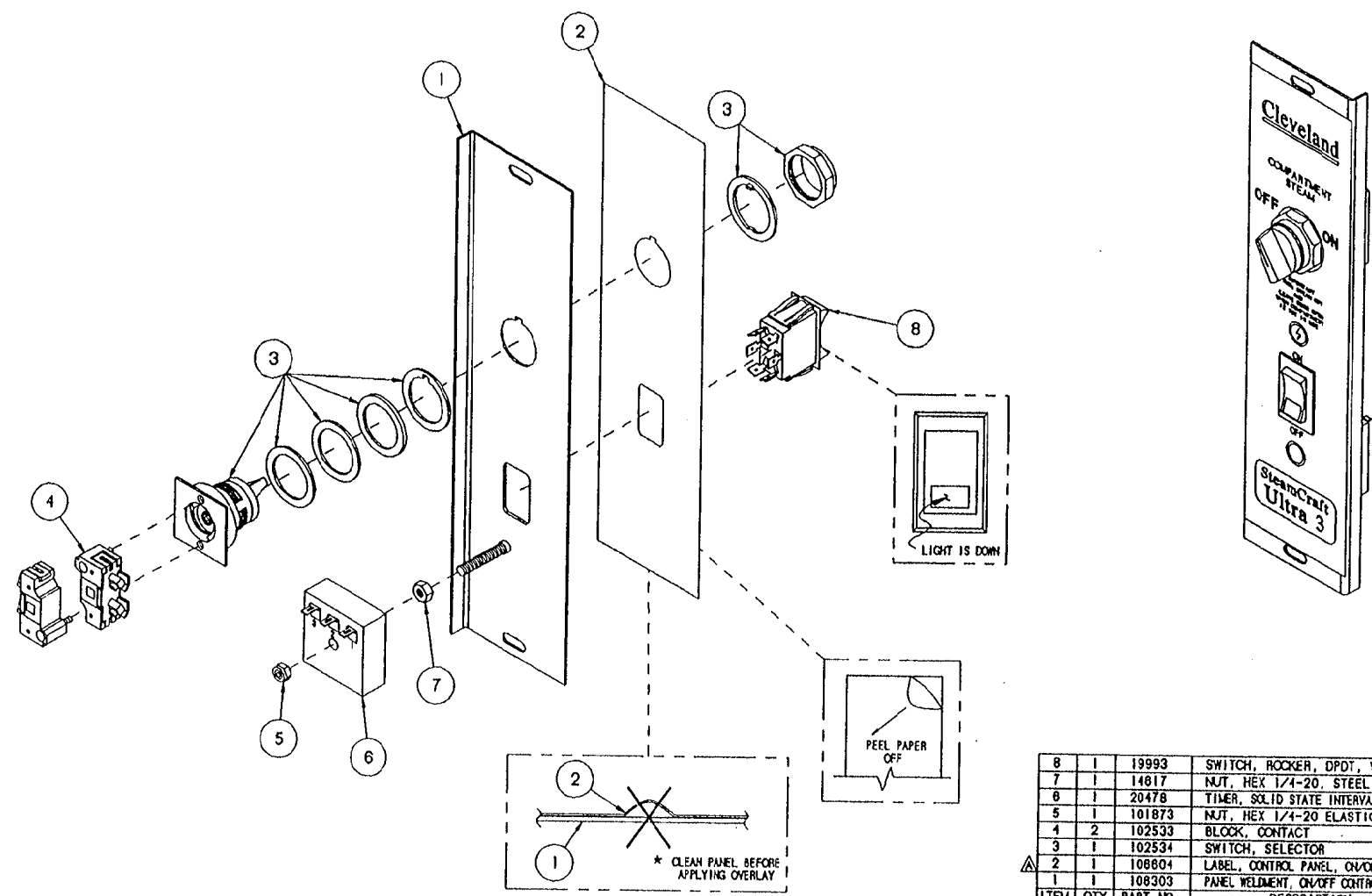

ITEM	QTY.	PART NO.	DESCRIPTION
8	1	19993	SWITCH, ROCKER, DPDT, W/ RED LIGHT
7	1	14817	NUT, HEX 1/4-20, STEEL
8	1	20478	TIMER, SOLID STATE INTERVAL 3 MINUTE
5	1	101873	NUT, HEX 1/4-20 ELASTIC LOCK
4	2	102533	BLOCK, CONTACT
3	1	102534	SWITCH, SELECTOR
2	1	108604	LABEL, CONTROL PANEL, ON/OFF, ULTRA 3
1	1	108303	PANEL WELDMENT, ON/OFF CONTROL, SC 3.1/5.1

<b>TOLERANCES</b> <small>(EXCEPT AS NOTED)</small>			
<b>CLEVELAND RANGE INC.</b> 1333 East 179th St. Cleveland, Ohio 44110-2574			
DECIMAL ± .030	SCALE 5/8" = 1"	DRAWN BY DUTCHMAN	APPROVED BY
ANGULAR ± 1°	TITLE CONTROL PANEL ASS'Y., ON/OFF STEAMCRAFT 3.1 ULTRA		
CK	DATE 01-15-93	DRAWING NO. C - 106304	REV. A

THIS DESIGN DESCRIBES A PROPRIETARY ITEM AND IS THE PROPERTY OF CLEVELAND RANGE. THIS DRAWING IS NOT TO BE COPIED OR USED WITHOUT THE APPROVAL OF CLEVELAND RANGE.

NOTES : 1.) USE LOCTITE #222 - LOW STRENGTH (#104148) ON ITEM 4

⚠ 2.) USE RTV (#00933) ON ITEM 8

⚠ 3.) ORIENT LONGER SIDE OF ITEM 5 TOWARD HANDLE

⚠ 4.) WHEN NAMEPLATE IS REQUIRED :  
ATTACH AT ASSEMBLY. DRILL HOLES FOR NAMEPLATE AND  
MOUNT P/Ns 105901 AND 104987 UNDER DOOR LATCH.

Magnetic latch  
110631

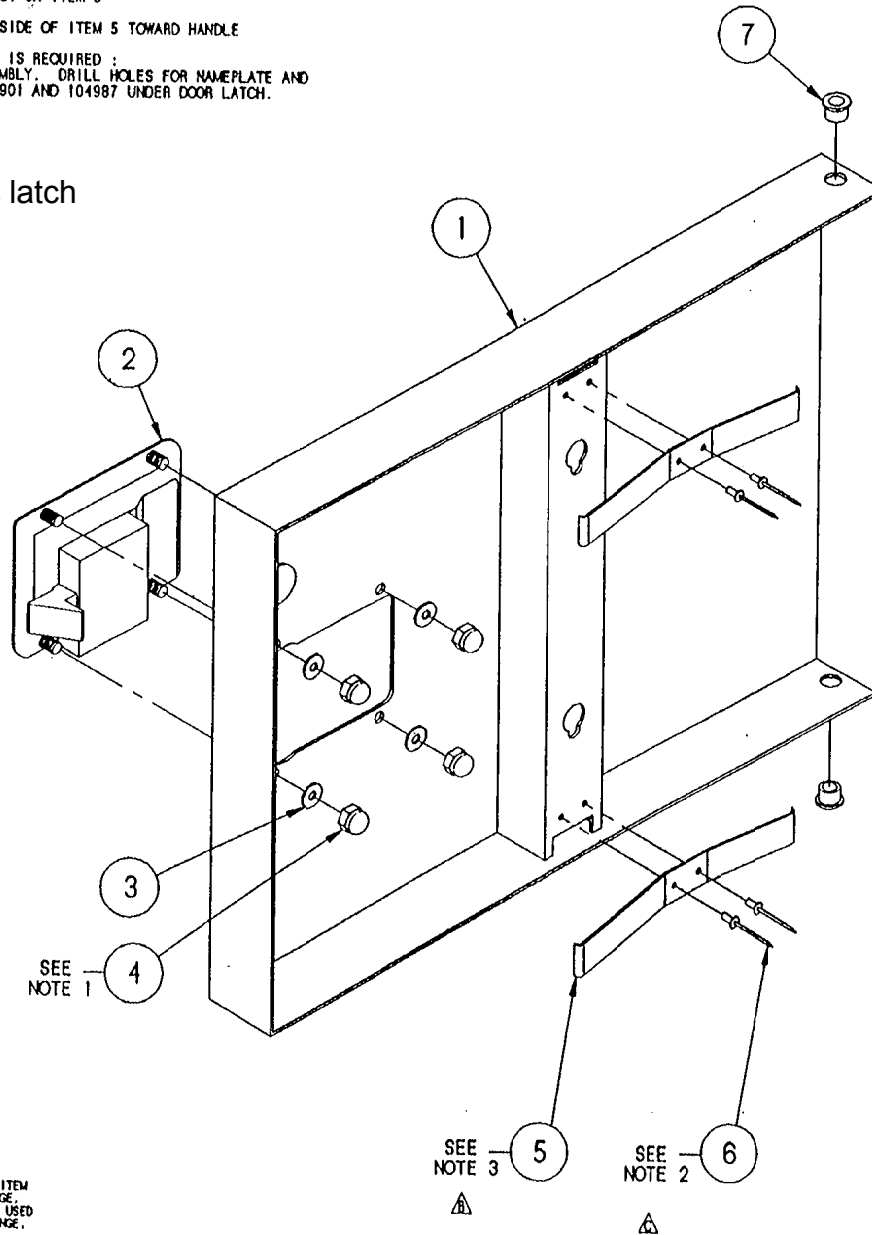

LET.	REVISIONS	DATE	BY
B	NOTE 3 WAS UPDATED, WAS ITEM 8 CALLOUT PER E.O. #C-1908	04-02-91	DJP
C	NOTE 2 REVISED, WAS ITEM 7 CALLOUT PER E.O. #C-1908 R1	03-19-92	PJO
D	P/Ns 105901 & 104987 ADDED PER E.O. #C-2441 R2	08-28-93	PJO
E	P/Ns 105901 & 104987 REF. ONLY PER E.O. #C-2441 R3	08-05-93	PJO
F	P/Ns 105901 & 104987 REMOVED PER E.O. #C-2441 R5	12-13-93	PJO

ITEM	QTY.	PART NO.	DESCRIPTION
7	2	103841	BUSHING, BRONZE
8	4	18357	RIVET, 1/8" DIA. FLUSH BREAK, S/S
5	2	102228	SPRING, DOOR
4	4	14879	NUT, #10-24 ACORN, S/S
3	4	101655	WASHER, #10 FLAT, S/S
2	1	103843	LATCH, DOOR - PADDLE TYPE
1	1	1035271	OUTER DOOR WELDMENT, H.L.

TOLERANCES (UNLESS AS NOTED)			
<b>CLEVELAND RANGE INC.</b> 1333 East 179th St. Cleveland, Ohio 44110-2574			
DECIMAL ± N/A	SCALE 5/8=1	DRAWN BY DUTCHMAN	APPROVED BY
ANGULAR ± N/A	TITLE DOOR, OUTER ASSEMBLY, H.L. SC 3.1 CONV. W/ SWITCH TUATOR		
CK	DATE 02-28-91	DRAWING NO. C - 10. 5/1	REV. F

THIS DESIGN DESCRIBES A PROPRIETARY ITEM  
AND IS THE PROPERTY OF CLEVELAND RANGE.  
DRAWING IS NOT TO BE COPIED OR USED  
WITHOUT THE APPROVAL OF CLEVELAND RANGE.

NOTES:

- 1.1 USE LOCKTITE #222 - LOW STRENGTH (#104148) ON ITEM 4
- ⚠ 2.1 USE RTV (#00933) ON ITEM 6
- ⚠ 3.1 ORIENT LONGER SIDE OF ITEM 5 TOWARD HANDLE
- ⚠ 4.1 WHEN NAMEPLATE IS REQUIRED:  
ATTACH AT ASSEMBLY. DRILL HOLES FOR NAMEPLATE AND  
MOUNT P/NS 105901 AND 104987 UNDER DOOR LATCH.

Magnetic latch  
110631

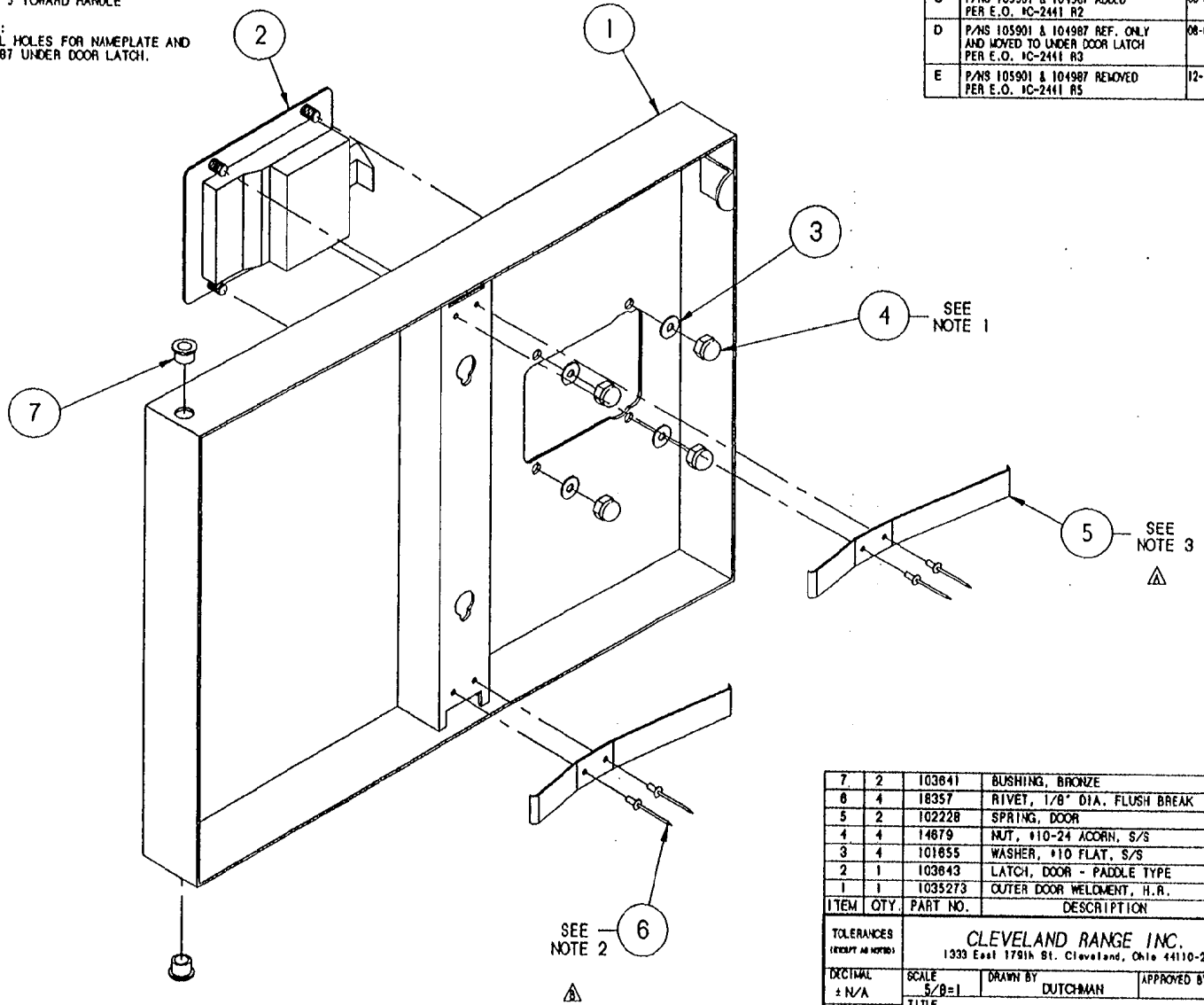

LET.	REVISIONS	DATE	BY
A	NOTE 3 WAS UPDATED, WAS ITEM 6 CALLOUT PER E.O. #C-1908	01-01-91	DJP
B	NOTE 2 REVISED, WAS ITEM 7 CALLOUT PER E.O. #C-1908 R1	03-19-92	FJO
C	P/NS 105901 & 104987 ADDED PER E.O. #C-2441 R2	08-30-93	FJO
D	P/NS 105901 & 104987 REF. ONLY AND MOVED TO UNDER DOOR LATCH PER E.O. #C-2441 R3	08-05-93	FJO
E	P/NS 105901 & 104987 REMOVED PER E.O. #C-2441 R5	12-13-93	FJO

ITEM	QTY	PART NO.	DESCRIPTION
7	2	103641	BUSHING, BRONZE
6	4	18357	RIVET, 1/8" DIA. FLUSH BREAK
5	2	102228	SPRING, DOOR
4	4	14879	NUT, #10-24 ACORN, S/S
3	4	101855	WASHER, #10 FLAT, S/S
2	1	103843	LATCH, DOOR - PADDLE TYPE
1	1	1035273	OUTER DOOR WELDMENT, H.R.

TOLERANCES (EXCEPT AS NOTED)			
<b>CLEVELAND RANGE INC.</b> 1333 East 1791A St. Cleveland, Ohio 44110-2574			
DECIMAL ± N/A	SCALE 5/8=1	DRAWN BY DUTCHMAN	APPROVED BY
ANGULAR ± N/A	TITLE DOOR, OUTER ASSEMBLY, H.R. SC 3.1 CONV. W/ SWITCH ACTUATOR		
DATE CK 02-28-91	DRAWING NO. C - 1035373	REV. E	

THIS DESIGN DESCRIBES A PROPRIETARY ITEM AND IS THE PROPERTY OF CLEVELAND RANGE. THIS DRAWING IS NOT TO BE COPIED OR USED WITHOUT THE APPROVAL OF CLEVELAND RANGE.

LET.	REVISIONS	DATE	BY
A	REVISED PER E.O. #C-1872 R5	2-28-91	P.J.D.
B	REVISED PER E.O. #C-1872 R7	5-13-91	P.J.D.
C	REVISED PER E.O. #C-1993	8-05-91	P.J.D.

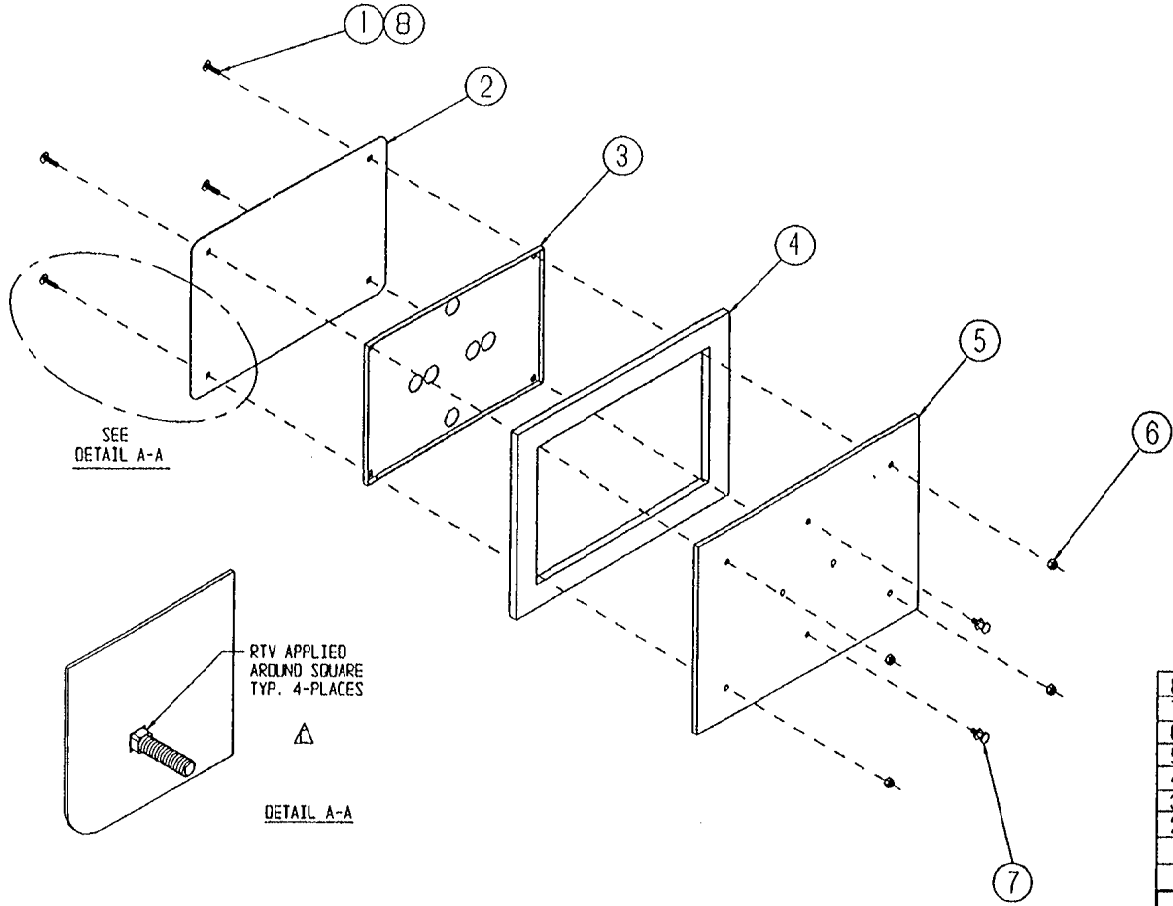

SEE  
DETAIL A-A

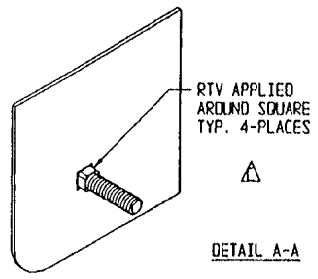

8	A/R	00932	SEALANT, RTV
7	2	19923	PIN GUIDE, INNER DOOR
6	4	14665	NUT, HEX LOCK 1/4-20
5		100745	INNER DOOR WELDMENT
4		07138	DOOR GASKET
3		66214	INNER GASKET RETAINER
2	1	66595	GASKET RETAINER PLATE
1	4	104719	BOLT, CARRIAGE 1/4-20 X 1.000"

ITEM	QTY.	PART NO.	DESCRIPTION
TOLERANCES (EXCEPT AS NOTED)			
<b>CLEVELAND RANGE INC.</b> 1333 East 179th St. Cleveland, Ohio 44110-2574			
DECIMAL ± N/A	SCALE N/A	DRAWN BY P. J. D.	APPROVED BY D. S.
ANGULAR ± N/A	TITLE DOOR, INNER ASS'Y. SC 3.1 CONV. (NEW STYLE MODEL C)		
CK	DATE 02-28-91	DRAWING NO. B-104101	REV. C

THIS DESIGN DESCRIBES A PROPRIETARY ITEM AND IS THE PROPERTY OF CLEVELAND RANGE. THIS DRAWING IS NOT TO BE COPIED OR USED WITHOUT THE APPROVAL OF CLEVELAND RANGE.

NOTE:

1) SEE FOLLOWING DRAWING FOR HOSE LOCATIONS :  
 STEAMCRAFT 3.1, ELECTRIC - 1063571

ASSEMBLED UNIT

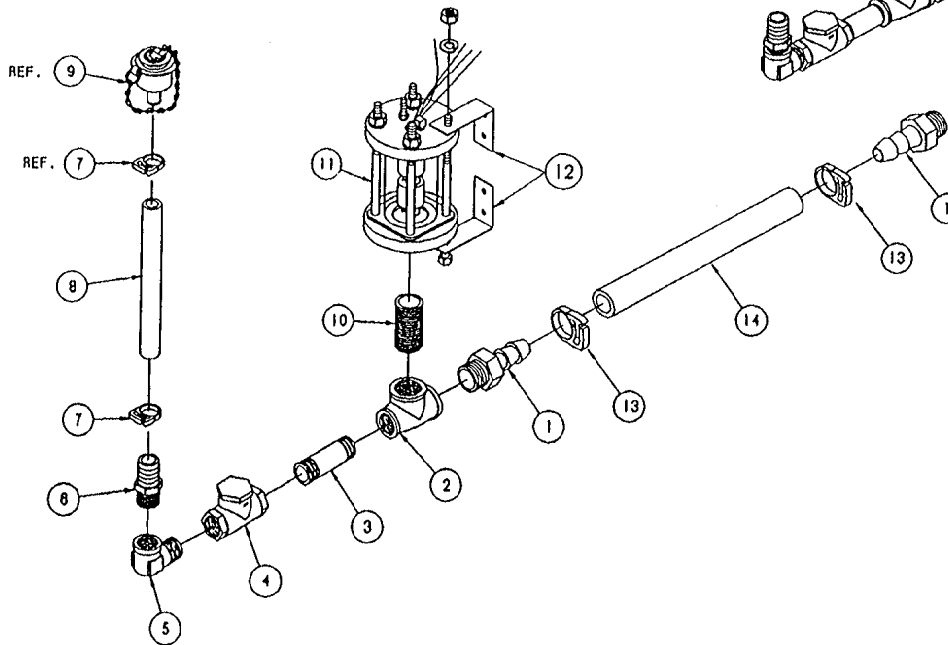
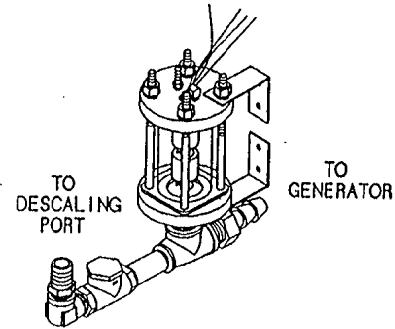

LET.	REVISIONS	DATE	BY
A	108104 & 108180 REPLACED WITH 108428 PER EO #C-2385	03-18-93	PJD
B	HOSE WAS 8", NOW 9" LG. PER EO #C-2385	04-15-93	PJD
C	SEE E.O. #C-2831	06-01-94	PJD

△	14	1	1080931000	HOSE, SILICONE, 3/4 ID X 1 OD X 10" LG
△	13	2	105847	CLAMP, PLASTIC, 1-1/8" HOSE
△	12	2	108878	BRACKET, TOP/BOT. FLOAT SUPPORT
	11	1	105877	FLOAT, ASSEMBLY, STEAMCRAFT
	10	1	14342	NIPPLE, 3/4 X CLOSE, RED BRASS
△	9	-	108428	PORT ASSEMBLY, DESCALER
△	8	1	1058450700	HOSE, NORPRENE, 1/2 ID X 3/4 OD X 7 LG
	7	1	105848	CLAMP, PLASTIC, 3/4" OD HOSE
	6	1	08237	FITTING, 1/2 X 1/2 MPT, BRASS
	5	1	05253	ELBOW, STREET, 90° X 1/2", BRASS
	4	1	108158	CHECK VALVE, 1/2" SWING W/ RUBBER SEAT
	3	1	14331	NIPPLE, 1/2" X 2-1/2", BRASS
	2	1	20208	TEE, 3/4 X 1/2 X 3/4, BRASS
△	1	2	08240	FITTING, 3/4 H X 3/4 MPT
	ITEM	QTY.	PART NO.	DESCRIPTION

TOLERANCES  
 (EXCEPT AS NOTED)

CLEVELAND RANGE INC.

1333 East 179th St. Cleveland, Ohio 44110-2574

DECIMAL ± .030	SCALE 1/4"	DRAWN BY DUTCHMAN	APPROVED BY
-------------------	---------------	----------------------	-------------

ANGULAR ± 1°	TITLE FLOAT AND DESCALER ASSEMBLY STEAMCRAFT 3.1
-----------------	--

CK	DATE 01-22-93	DRAWING NO. B - 106227	REV. C
----	------------------	---------------------------	-----------

THIS DESIGN DESCRIBES A PROPRIETARY ITEM AND IS THE PROPERTY OF CLEVELAND RANGE. THIS DRAWING IS NOT TO BE COPIED OR USED WITHOUT THE APPROVAL OF CLEVELAND RANGE.

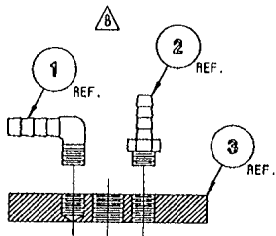

DETAIL A-A  
SCALE: 1/2=1

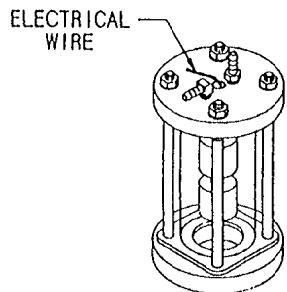

ASSEMBLED VIEW  
SCALE: 1/4=1

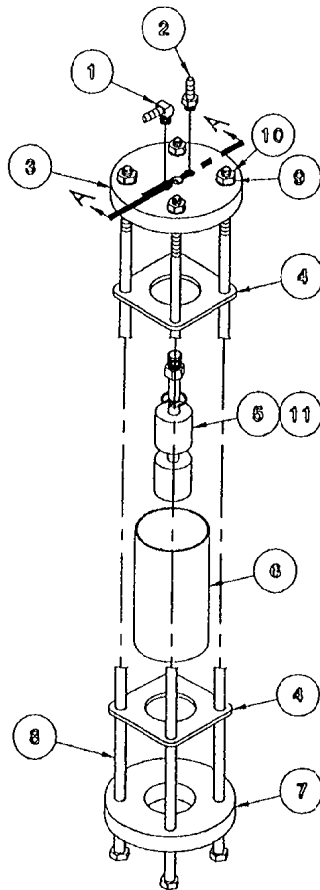

EXPLODED ASSEMBLY  
SCALE: 1/4=1

REFERENCE:  
260AHM 5 OF 5

THIS DESIGN DESCRIBES A PROPRIETARY ITEM  
AND IS THE PROPERTY OF CLEVELAND RANGE.  
THIS DRAWING IS NOT TO BE COPIED OR USED  
WITHOUT THE APPROVAL OF CLEVELAND RANGE.

LET.	REVISIONS	DATE	BY
A	CORRECTED P/N 105787	7-30-92	SM
B	ROTATED 90° P/NS 105787 & 104380 PER EO *C-2304	10-10-92	PD
C	THIS ASSEMBLY REPLACES P/N 104091 ON SC 3.1, 5.1 ELECT. & SC 10 ELECT. PER EO *C-2277 R3	02-02-93	PD

ITEM	QTY.	PART NO.	DESCRIPTION
11	A/R	00934	SEALANT, RECTORSEAL
10	4	1461B	NUT, HEX HEAD, 1/4-20, S/S
9	4	23105	WASHER, SPLIT LOCK, 1/4, S/S
8	4	104276	SCREW, HEX HEAD, 1/4-20 x 5.5, S/S
7	1	104040	CAP, FLOAT BOTTOM
6	1	1040190388	TUBE, POLYSULFONE, 2 x .125 x 3.875
5	1	103728	SWITCH ASSEMBLY, FLOAT
4	2	104041	GASKET, FLOAT ASSEMBLY
3	1	104039	TOP, FLOAT, STEAMCRAFT
2	1	104380	FITTING, HOSE BARB, 1/4 H x 1/8 MPT
1	1	105787	FITTING, HOSE BARB, 90°, 1/4 H x 1/8 MPT

TOLERANCES (EXCEPT AS NOTED)		CLEVELAND RANGE INC. 1333 East 179th St. Cleveland, Ohio 44110-2574	
DECIMAL ± N/A	SCALE AS SHOWN	DRAWN BY S. MILEWSKI	APPROVED BY
ANGULAR ± N/A	TITLE △ FLOAT ASSEMBLY, STEAMCRAFT 10 ELECTRIC, 3.1 AND 5.1		
CK	DATE 05-28-92	DRAWING NO. B - 105877	REV. C

# 107241 Water Level Board

## GENERAL DESCRIPTION

THIS SOLID STATE CONTROLLER SERVES AS A DUAL LEVEL WATER SENSING DEVICE. IT'S FUNCTIONS ARE TO:

1. MONITOR AND MAINTAIN A PRESET OPERATING WATER LEVEL WITHIN A STEAM GENERATOR VESSEL, AND
2. MONITOR THE SAFE LOW WATER LIMIT FOR HEATER OPERATION AND PROVIDE HEATER LOCK-OUT FOR UNSAFE OPERATION.

EACH FUNCTION WILL BE CONTROLLED BY RESISTANCE SENSING BETWEEN THE PROBES ("HI" & "LOW" TERMINALS) AND A GROUNDED COMMON ("C" TERMINAL).

## LOW PROBE OPERATION

WHEN WATER CONTACTS PROBE, RESISTANCE BETWEEN "LOW" PROBE AND COMMON "C" WILL BE BELOW SET POINT (50 K OHM) AND OUTPUT RELAY WILL BE ACTIVATED IMMEDIATELY TO SUPPLY 120 VAC FROM L1 TO HTR TERMINAL. WHEN CONTACT BETWEEN WATER AND PROBE IS BROKEN (RESISTANCE GREATER THAN 50 K OHM) THE RELAY WILL BE DEACTIVATED WITHIN 0-2 SECONDS.

## HI PROBE OPERATION

AS WATER MAKES CONTACT WITH PROBE, RESISTANCE BETWEEN "HI" AND COMMON "C" WILL BE BELOW SET POINT (50 K OHM) AND OUTPUT RELAY IS DEACTIVATED IMMEDIATELY. WHEN WATER BREAKS CONTACT WITH "HI" PROBE DELAY TIMING STARTS. TIMING IS NOT ACCUMULATIVE AND DELAY TIMER WILL BE RESET TO ZERO ANY TIME RESISTANCE BETWEEN "HI" PROBE AND COMMON "C" GOES BELOW SET POINT (50 K OHM). WHEN RESISTANCE BETWEEN HI PROBE AND COMMON "C" REMAINS ABOVE SET POINT FOR MORE THAN 5 SEC. (-2,+0 SEC.) THE OUTPUT RELAY ACTIVATED TO PROVIDE 120 VAC FROM L1 TO WF TERMINAL.

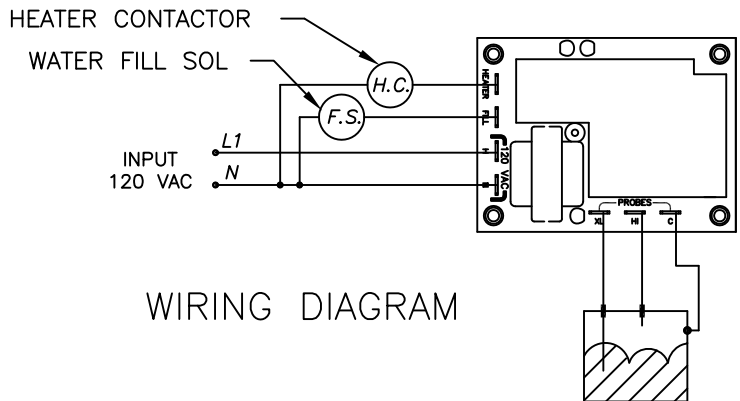
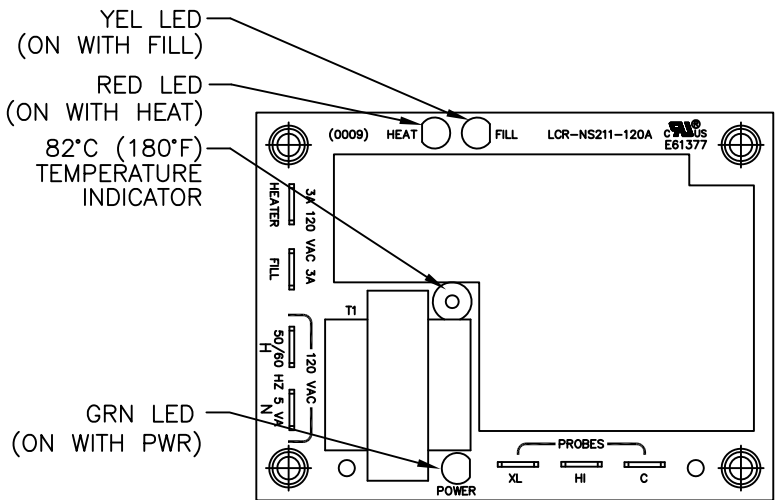

WIRING DIAGRAM

# 107239 Water Level Probe Assembly

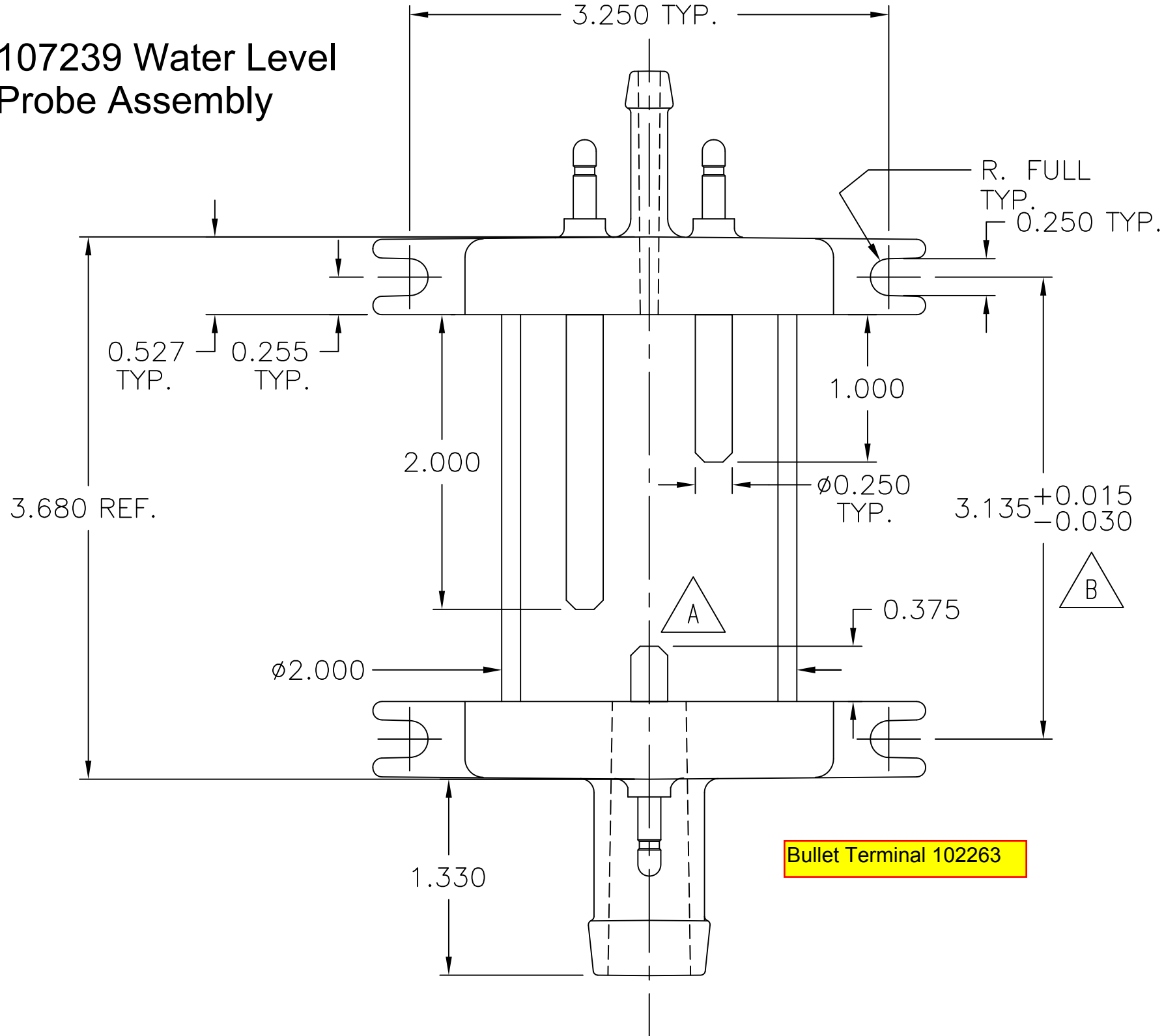

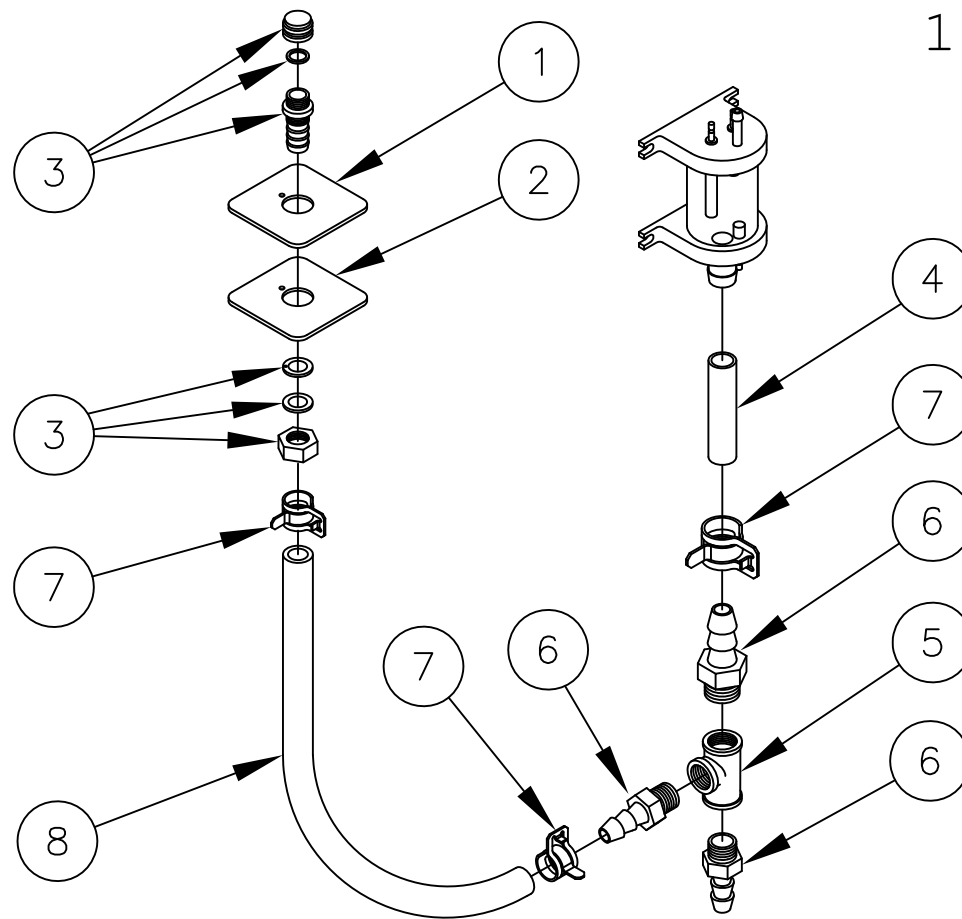

Bullet Terminal 102263

8	1	085112700	HOSE, WHITE, EPDM, 3/4 ID X 27.000 LG
7	2	107312	CLAMP, HOSE METAL TENSION, 1.125 OD HOSE
6	2	06240	FITTING, HOSE BARB, 3/4 X 3/4
5	1	20206	TEE, 3/4 BRASS
4	1	085110600	HOSE, WHITE, EPDM, 3/4 ID X 6.000
3	1	109641	PORT ASSEMBLY, DESCALER
2	1	108724	PLATE, DESCALER PORT CVRSN
1	1	108723	GASKET, DESCALER PORT CVRSN

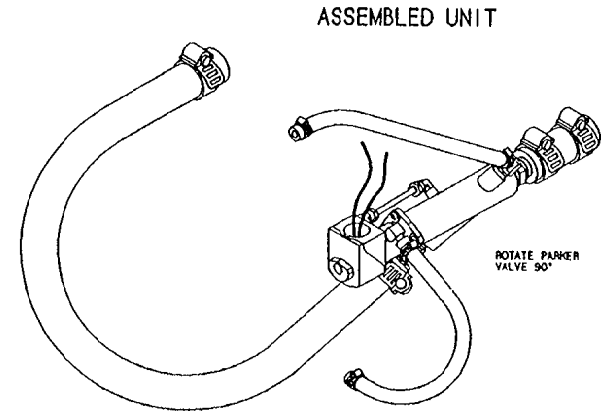
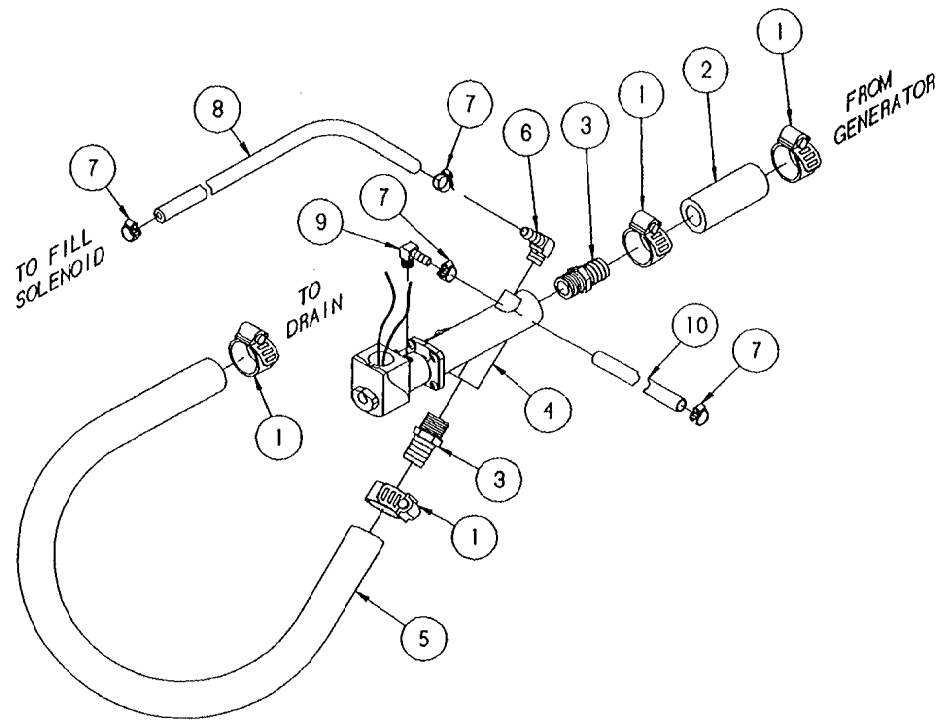

ITEM	QTY.	PART NO.	DESCRIPTION
10	1	1058500600	HOSE, NT-80, 1/4 X 1/2 X 6' LG.
9	1	105787	FITTING, HOSE 1/4 H X 1/8 MPT, 90°
8	1	1058500900	HOSE, NT-80, 1/4 X 1/2 X 9' LG.
7	4	108219	CLAMP, METAL, WORM DRIVE
6	1	105788	FITTING, HOSE 1/4 H X 1/4 MPT, 90°
5	1	085051400	HOSE, DARTPREEN 3/4" ID X 14" LG.
4	1	22244	VALVE, DRAIN, PARKER
3	2	08246	FITTING, HOSE 3/4 H X 3/4 NPT, STR
2	1	085050300	HOSE, DARTPREEN 3/4" ID X 3" LG.
1	4	03207	CLAMP, METAL, WORM DRIVE

TOLERANCES (EXCEPT AS NOTED)			
<b>CLEVELAND RANGE INC.</b> 1333 East 179th St., Cleveland, Ohio 44110-2574			
DECIMAL ± N/A	SCALE 3/8=1	DRAWN BY DUTCHMAN	APPROVED BY
ANGULAR ± N/A		TITLE VALVE ASSEMBLY, DRAIN STEAMCRAFT 5.1, GAS	
DATE CK	05-12-93	DRAWING NO. C - 106524	REV. -

THIS DESIGN DESCRIBES A PROPRIETARY ITEM AND IS THE PROPERTY OF CLEVELAND RANGE. THIS DRAWING IS NOT TO BE COPIED OR USED WITHOUT THE APPROVAL OF CLEVELAND RANGE.

LET.	REVISIONS	DATE	BY
A	ADDED NOTE FOR ASSEMBLY.	04/13/95	NT

NOTE: 1) Rotate solenoid valve 45° clockwise for left hinging units. Rotate solenoid valve 45° counter-clockwise for right hinging units.

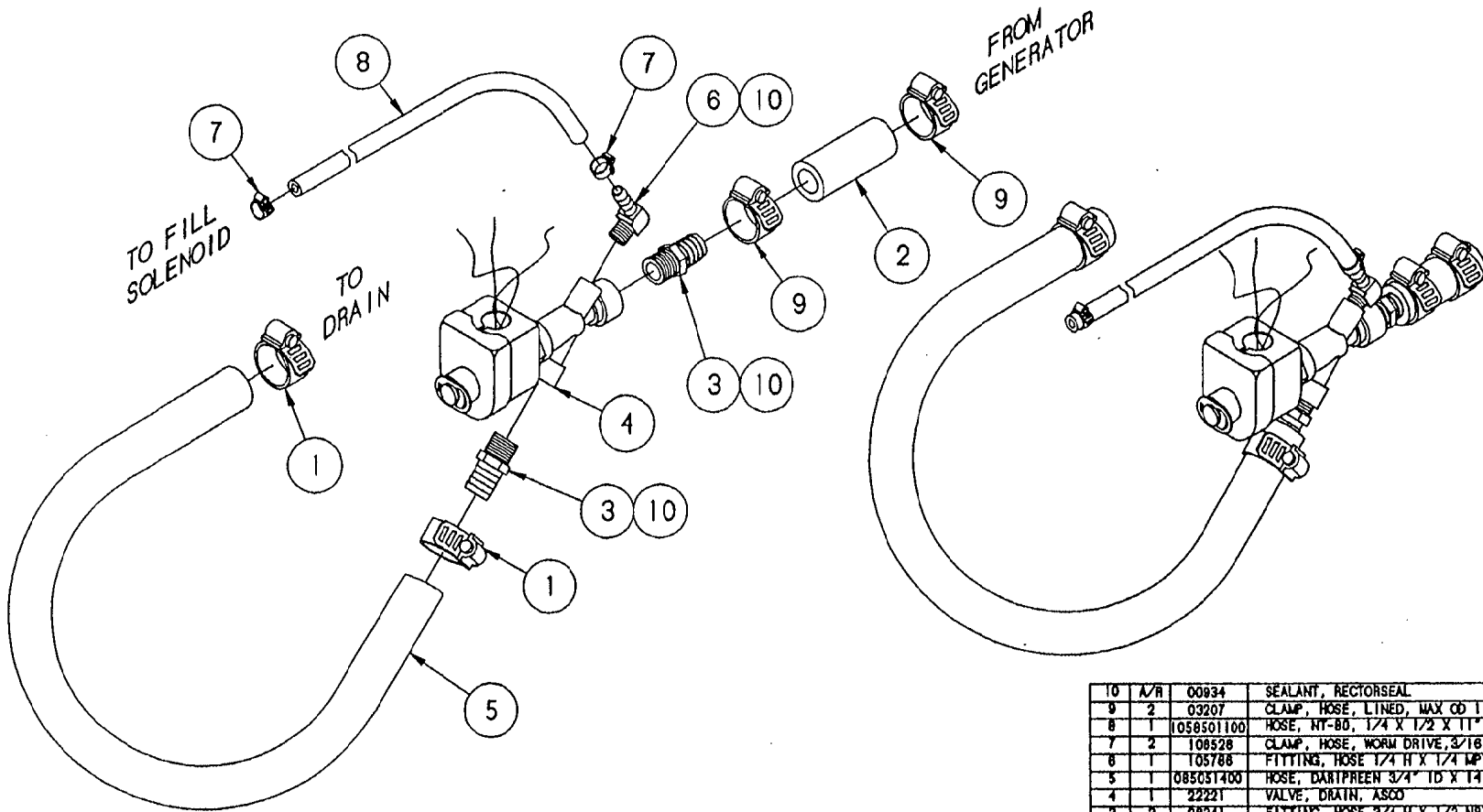

ITEM	QTY.	PART NO.	DESCRIPTION
10	A/R	00834	SEALANT, RECTORS SEAL
9	2	03207	CLAMP, HOSE, LINED, MAX OD 1.125"
8	1	1058501100	HOSE, NY-BD, 1/4 X 1/2 X 11" LG.
7	2	108528	CLAMP, HOSE, WORM DRIVE, 3/16-5/16
6	1	105788	FITTING, HOSE 1/4 H X 1/4 MPY, 90°
5	1	085051400	HOSE, DARTPREEN 3/4" ID X 14" LG.
4	1	22221	VALVE, DRAIN, ASCO
3	2	08241	FITTING, HOSE 3/4 H X 1/2 NPT, STR
2	1	085110300	HOSE, STLBRDE, 3/4" ID X 3" LG.
1	2	03204	CLAMP, HOSE, WORM DRIVE, 3/4"

TOLERANCES (EXCEPT AS NOTED)		CLEVELAND RANGE INC. 1333 East 170th St. Cleveland, Ohio 44110-2574	
DECIMAL ± N/A	SCALE 1/2" = 1"	DRAWN BY DUTCHMAN	APPROVED BY
ANGULAR ± N/A	TITLE VALVE ASSEMBLY, DRAIN STEAMCRAFT 3.1 AND 5.1		
CK	DATE 02-12-93	DRAWING NO. C - 106384	REV. A

THIS DESIGN DESCRIBES A PROPRIETARY ITEM AND IS THE PROPERTY OF CLEVELAND RANGE. THIS DRAWING IS NOT TO BE COPIED OR USED WITHOUT THE APPROVAL OF CLEVELAND RANGE.

NOTE:  
1. USE THREAD JOINT COMPOUND AS REQUIRED TO SEAL.

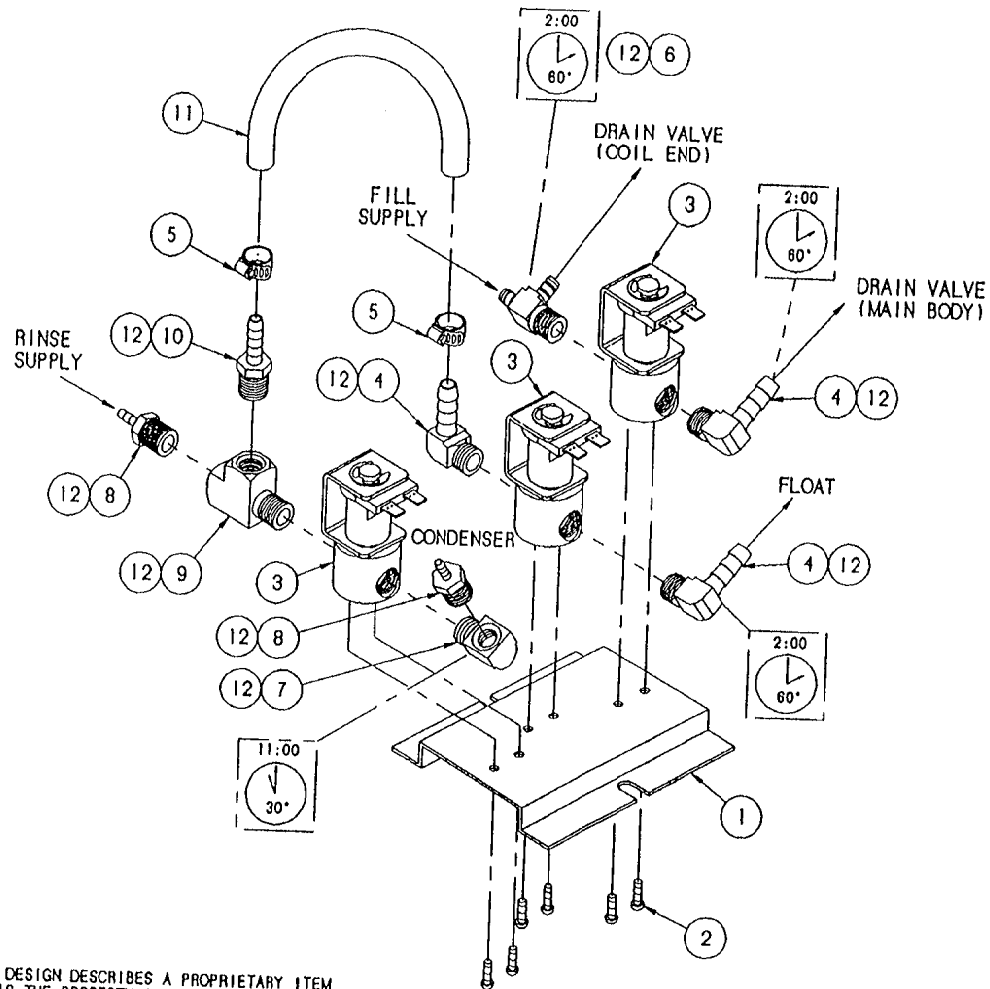

LET.	REVISIONS	DATE	BY
A	106522 REPLACED 104087, 106526 REPLACED 106219, ADDED NEW PARTS & NEW TUBING LAYOUT PER E.O. #C-2492	08-23-93	PJD

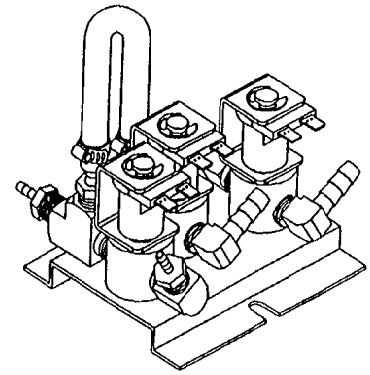

SEE NOTE 1

ITEM	QTY.	A/R	PART NO.	DESCRIPTION
			12 00934	SEALANT, RECTORSEAL
△	11	1	1058500600	TUBING, NT-80, 1/4" X 6"
	10	1	104381	FITTING, HOSE, 1/4 H X 1/4 MPT, STR.
△	9	1	106663	FITTING, MALE RUN, 1/4 MPT X 1/4 FPT
△	8	2	106661	FITTING, HOSE, 1/8 H X 1/4 MPT, STR.
△	7	1	05235	ELBOW, STREET 1/4 X 90°, BRASS
	6	1	106588	FITTING, TEE, 1/4 H X 1/4 MPT X 1/4 H
△	5	2	106526	CLAMP, HOSE, 3/8 X 5/8 X 5/16 W
	4	3	105786	FITTING, HOSE, 1/4 H X 1/4 MPT, 90°
	3	3	22218	SOLENOID VALVE
	2	6	101872	SCREW, #8-32 X 1/4 THD. CUT
	1	1	104284	BRACKET, MOUNTING

<b>TOLERANCES</b> <small>(EXCEPT AS NOTED)</small>				<b>CLEVELAND RANGE INC.</b> 1333 East 179th St. Cleveland, Ohio 44110-2574			
DECIMAL	± N/A	SCALE	1/2 = 1	DRAWN BY	ARB	APPROVED BY	
ANGULAR	± 1°	TITLE VALVE ASSY, WATER INLET SC 3.1 & 5.1, H.L.					
CK	DATE	08-24-93	DRAWING NO.	B - 106522	REV.	A	

THIS DESIGN DESCRIBES A PROPRIETARY ITEM AND IS THE PROPERTY OF CLEVELAND RANGE. THIS DRAWING IS NOT TO BE COPIED OR USED WITHOUT THE APPROVAL OF CLEVELAND RANGE.

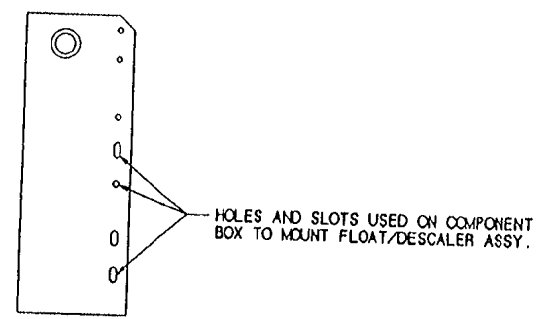
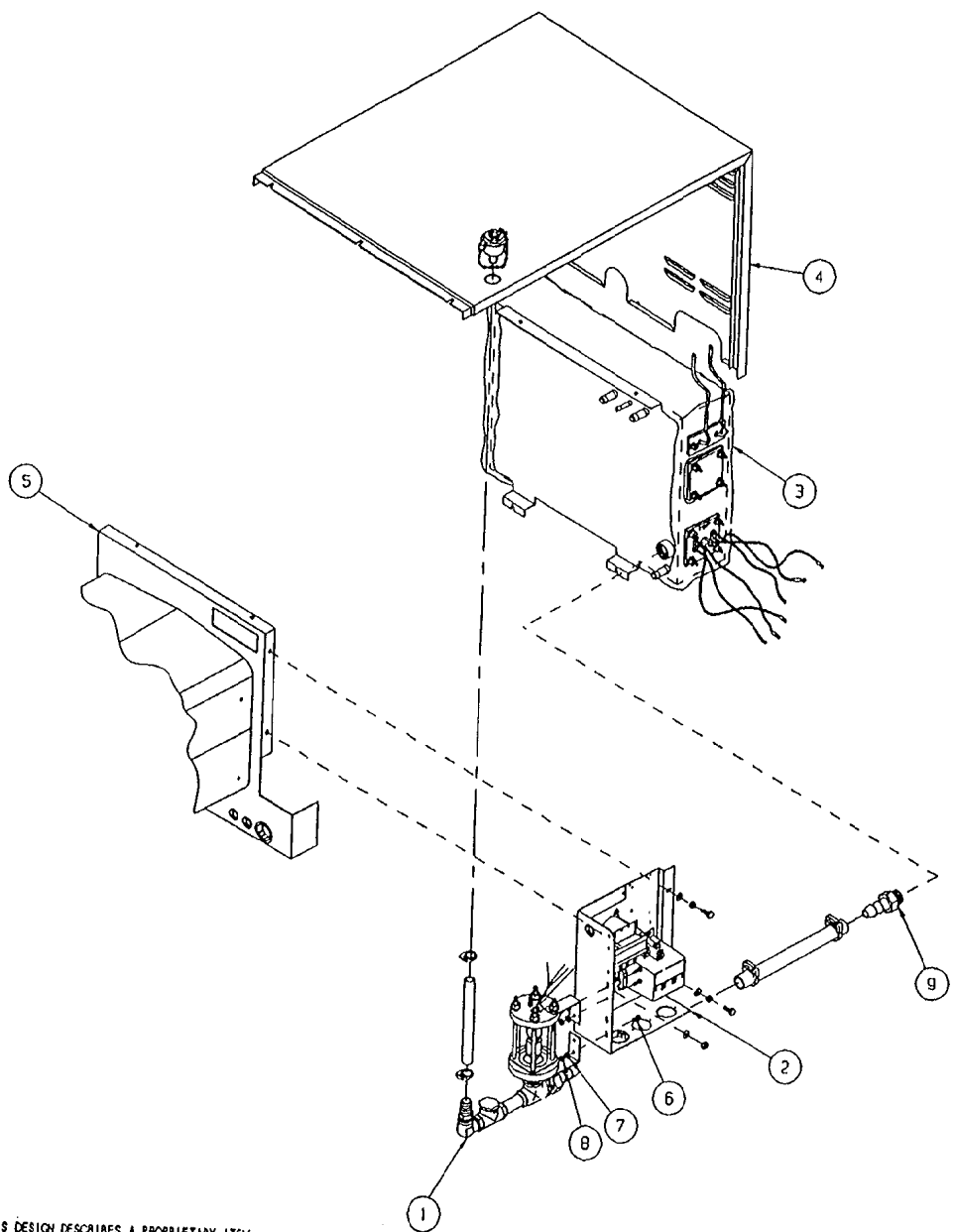

ITEM	QTY.	PART NO.	DESCRIPTION
9	1	06240	FITTING, 3/4 H X 3/4 MPT
8	3	14692	NUT, HEX LOCK ELASTIC 10-24
7	3	101655	WASHER, FLAT #10, S/S
8	3	19287	SCREW, PAN HEAD 10-24 X 1/2, S/S
5	-	1040951	CAVITY, WELD ASSY., H.L.
4	-	103942	SHEETING, TOP/BACK
3	-	104090	GENERATOR ASSY.
2	1	104093	COMPONENT PANEL ASSY.
1	1	106227	FLOAT AND DESCALER ASSY.

TOLERANCES (EXCEPT AS NOTED)		CLEVELAND RANGE INC. 1333 East 179th St. Cleveland, Ohio 44110-2574	
DECIMAL ± N/A	SCALE 3/16=1	DRAWN BY DUTCHMAN	APPROVED BY
ANGULAR ± N/A	TITLE INSTALLATION OF FLOAT/DESCALER TO COMPONENT BOX ON ULTRA 3 ELECTRIC		
CK	DATE 07-14-94	DRAWING NO. C - 260AKW	REV. -

THIS DESIGN DESCRIBES A PROPRIETARY ITEM AND IS THE PROPERTY OF CLEVELAND RANGE. THIS DRAWING IS NOT TO BE COPIED OR USED WITHOUT THE APPROVAL OF CLEVELAND RANGE.

LET.	REVISIONS	DATE	BY
A	SEE E.O. 12872	12-18-94	PJD

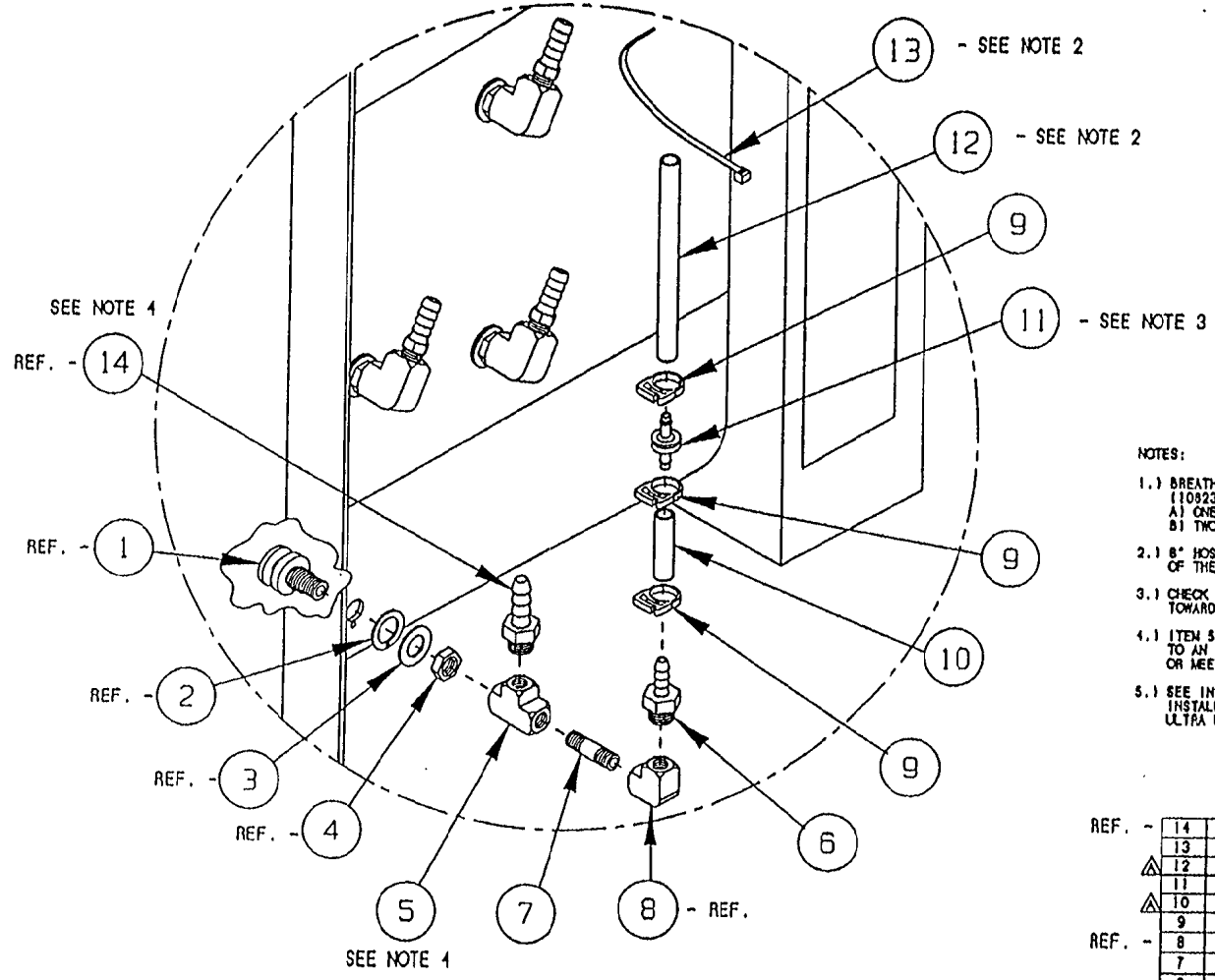

NOTES:

- 1.) BREATHER ASSY. (1070591) TO REPLACE ONE SPRAY NOZZLE ASSY. (1082301) ONE PLACE PER CAVITY ON ALL STEAMCRAFT ULTRA UNITS  
 A) ONE COMPARTMENT UNITS = ONE BREATHER ASSY.  
 B) TWO COMPARTMENT UNITS = TWO BREATHER ASSY.
- 2.) 8" HOSE IS TO BE SECURED WITH NYLON CABLE TO THE HOSE OF THE SPRAY NOZZLE ASSY. DIRECTLY ABOVE THE NEW ASSY.
- 3.) CHECK VALVE - SIDE WHICH READS "VAC" MUST FACE DOWN TOWARD HOSE BARB
- 4.) ITEM 5 (P/N 20199) AND ITEM 6 (P/N 104081) TO BE ROTATED TO AN ANGLE THAT WILL MATCH THE OTHER SPRAY NOZZLES OR MEET A MATING HOSE FITTING
- 5.) SEE INSTRUCTIONAL DRAWINGS 280ALB1-280ALB7 FOR INSTALLATION OF THIS ASSEMBLY INTO THE STEAMCRAFT ULTRA UNITS.

REF.	QTY.	PART NO.	DESCRIPTION
REF. - 14	-	104048	FITTING, 1/2 HOSE X 1/4 MPT
REF. - 13	1	20451	TIE, NYLON CABLE
REF. - 12	1	1043790500	HOSE, SILICONE 1/4 ID X 1/2 OD X 5'
REF. - 11	1	107032	CHECK VALVE, PLASTIC DIAPHRAGM
REF. - 10	1	1043790300	HOSE, SILICONE 1/4 ID X 1/2 OD X 3'
REF. - 9	3	104383	CLAMP, HOSE, NYLON
REF. - 8	-	05238	ELBOW, 1/4 X 90°, BRASS
REF. - 7	1	14411	NIPPLE, 1/4 X 1.5', BRASS
REF. - 6	1	104381	FITTING, 1/4 HOSE X 1/4 MPT
REF. - 5	1	20199	TEE, 1/4 BRASS
REF. - 4	-	104081	NUT, HEX JAM 5/8-18 BRASS
REF. - 3	-	104232	WASHER, FLAT 5/8
REF. - 2	-	104082	GASKET, STEAM INJECTOR
REF. - 1	-	104009	FITTING ASSY., STEAM SUPPLY

THIS DESIGN DESCRIBES A PROPRIETARY ITEM AND IS THE PROPERTY OF CLEVELAND RANGE. THIS DRAWING IS NOT TO BE COPIED OR USED WITHOUT THE APPROVAL OF CLEVELAND RANGE.

TOLERANCES (UNLESS OTHERWISE NOTED)		CLEVELAND RANGE INC. 1333 East 179th St. Cleveland, Ohio 44110-2574	
DECIMAL	SCALE	DRAWN BY	APPROVED BY
± N/A	3/16±1	DUTCHMAN	
ANGULAR	TITLE	BREATHER/SPRAY NOZZLE ASSY. (1/2" HOSE) STEAMCRAFT ULTRA 3, 5 & 10	
± N/A			
DATE	DRAWING NO.	REV.	
OK 03-15-94	C - 1070591	A	

LET.	REVISIONS	DATE	BY
------	-----------	------	----

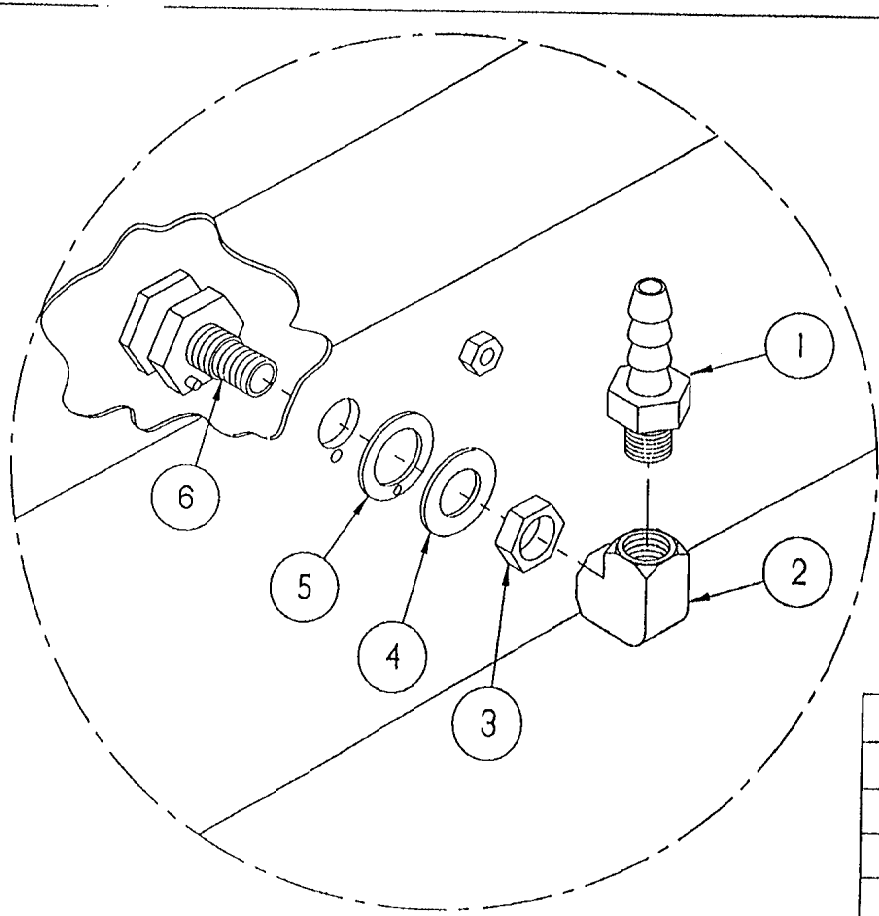

TYPICAL APPLICATION

ITEM	QTY.	PART NO.	DESCRIPTION
6	1	104009	FITTING, ASSY, STEAM SUPPLY
5	1	104082	GASKET, STEAM INJECTOR
4	1	104232	WASHER, FLAT S/S
3	1	104081	NUT, JAM 5/8-18, BRASS
2	1	05236	ELBOW, 1/4" X 90°, BRASS
1	1	104048	FITTING, HOSE 1/2 H X 1/4 MPT

TOLERANCES (EXCEPT AS NOTED)		<b>CLEVELAND RANGE INC.</b> 1333 East 179th St. Cleveland, Ohio 44110-2574	
DECIMAL ± .030	SCALE 1/2"		
ANGULAR ± 1°	TITLE SPRAY NOZZLE ASSEMBLY STEAMCRAFT 3.1, 5.1 AND 10		
CK	DATE 02-12-93	DRAWING NO. A - 1062301	REV. -

THIS DESIGN DESCRIBES A PROPRIETARY ITEM AND IS THE PROPERTY OF CLEVELAND RANGE. THIS DRAWING IS NOT TO BE COPIED OR USED WITHOUT THE APPROVAL OF CLEVELAND RANGE.

NOTES :

1. SEE WIRING DIAGRAM 104108 OR 104165 FOR CONNECTION LOCATION .

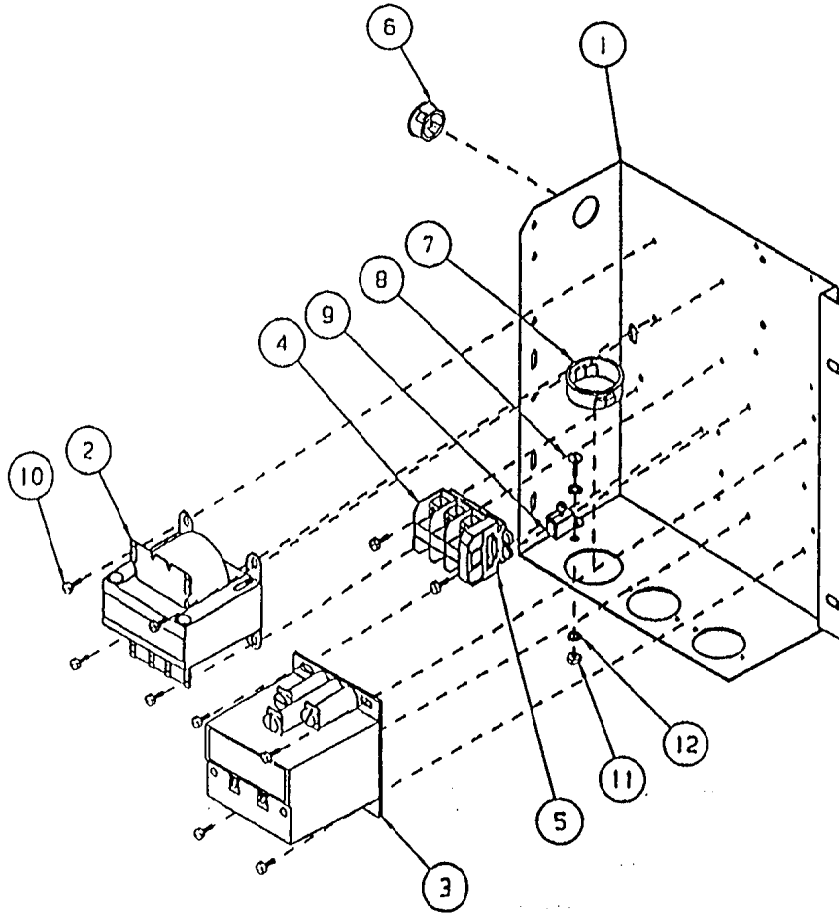

LET.	REVISIONS	DATE	BY
A	101541 WAS QTY. OF 1, 101540 WAS QTY. OF 3, 104223 WAS QTY. OF 14, ACCED 104225 & 1042251 PER E.O. # C-1876 R2	03-28-91	P.D
B	OMITTED 104223 & 101336, ACCED 106127, 15010 AND 18358, 103936 WAS 104092 PER E.O #C-2502	09-14-93	P.D
C	P/N 108754 WAS 106127, REMOVED S/N TAG PER ED #C2548	01/14/94	DFA

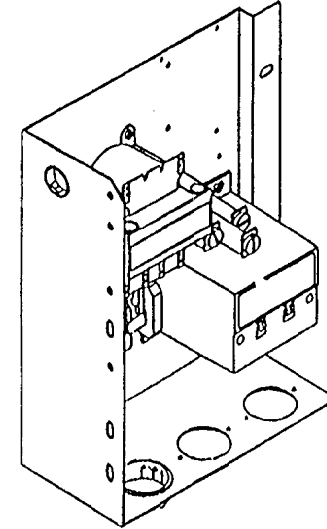

ITEM	QTY.	PART NO.	DESCRIPTION
SEE NOTE 1	14	2	1042251 WIRE ASSEMBLY
	13	3	104225 WIRE ASSEMBLY
	12	2	23114 WASHER, INTERNAL TORX™, #10 S/S
	11	1	14650 NUT, HEX 10-24, S/S
	10	10	1018754 SCREW, HEX/WASHER HEAD, #10 X 3/20
	9	1	20304 GROUND LUG, BURNDY #3PAIL
	8	1	101231 SCREW, 10-24 X 1/2 TRUSS HEAD, S/S
	7	1	102581 BUSHING, HEYCO, SNAP-IN
	6	1	02600 BUSHING, HEYCO SB-875-11, INSULATOR
	5	1	101540 END SEGMENT, TERMINAL BLOCK, 85 AMP
	4	3	101541 TERMINAL SEGMENT, CLAMP TYPE, 85 AMP
	3	1	103905 CONTACTOR, 30 AMP, MER 3 PH
	1	1	104234 CONTACTOR, 30 AMP, MER 1 PH
	2	1	20533 TRANSFORMER 75 VA, 240/480 PRIMARY, 120 SECONDARY 100%
	1	1	103936 PANEL, COMPONENT WELD ASSY.
			DESCRIPTION
TOLERANCES (UNLESS SHOWN)			CLEVELAND RANGE INC. 1333 East 179th St., Cleveland, Ohio 44110-2574
DECIMAL & FRA	SCALE 1/2	DRAWN BY R. RIDS	APPROVED BY J.B.
DECIMAL & FRA	TITLE COMPONENT PANEL, H.L. STEAMCRAFT 3.1		
CK	DATE 07-09-90	DRAWING NO. C - 104093	REV. C

THIS DESIGN DESCRIBES A PROPRIETARY ITEM AND IS THE PROPERTY OF CLEVELAND RANGE. THIS DRAWING IS NOT TO BE COPIED OR USED WITHOUT THE APPROVAL OF CLEVELAND RANGE.

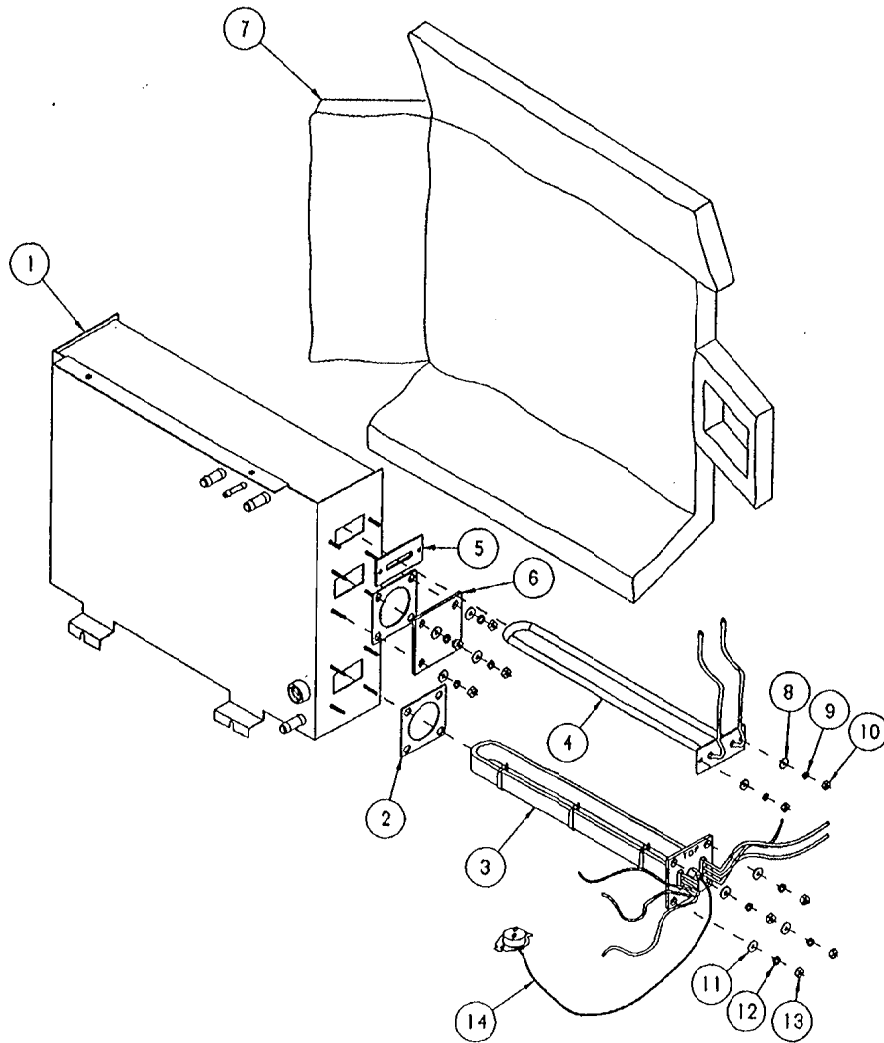

THIS DESIGN DESCRIBES A PROPRIETARY ITEM AND IS THE PROPERTY OF CLEVELAND RANGE. THIS DRAWING IS NOT TO BE COPIED OR USED WITHOUT THE APPROVAL OF CLEVELAND RANGE.

LET.	REVISIONS	DATE	BY
A	CHANGED QTY. ON 23118, 23105, 14618 CHANGED PART NO. ON 10548, PER E.O. 1757	8-01-90	RR
B	ADDED 10548 ; CHANGED 104308 ; E.O. C-1769	9-29-90	RR
C	07128 CHANGED TO QTY. 2, ADDED P/N FOR 104388, PER E.O. 1794	10-02-90	RR
D	REMOVED ITEMS, REVISED 104089 & 104091 PICTORIAL ; PER E.O. 1878	2-12-91	PD
E	ADDED HEATER & ELEMENT VARIATIONS AND ADDED P/N 103731 TO PARTS LIST, P/N 104091 PICTORIAL REVISED PER E.O. 4C-2217	01-12-93	PJD
F	P/N 105877 WAS 104091 PER E.O. 4C-2277 R3	02-02-93	PJD
G	REMOVED FLOAT ASSEMBLY (P/Ns 105877 05231 & 104064) PER 4C-2631	05-19-94	PJD

△	14	1	103731	CAPILLARY, HI LIMIT
△	13	8	14618	NUT, HEX, 1/4-20 S/S
△	12	8	23105	WASHER, LOCK, 1/4 S/S
△	11	8	23118	WASHER, FLAT 1/4 X 5/8
	10	2	14659	NUT, HEX, 10-24 S/S
	9	2	23113	WASHER, LOCK, SPLIT RING, CAD PLATED, #10
	8	2	101855	WASHER, FLAT, #10 S/S
	7	1	104080	INSULATION, CUT, GENERATOR 3.1
△	6	1	10548	COVER PLATE
△	5	1	104388	GASKET, DRYING ELEMENTS
	-	-	1043084	ELEMENT, IMMERSION, 300W, 415 V
	-	-	1043083	ELEMENT, IMMERSION, 300W, 380 V
	-	-	1043082	ELEMENT, IMMERSION, 300W, 480 V
△	4	-	1043061	ELEMENT, IMMERSION, 300W, 240 V
	-	-	104308	ELEMENT, IMMERSION, 300W, 208 V
	-	-	1038815	HEATER ASSY, 8 kw, 380 V
	-	-	1038814	HEATER ASSY, 8 kw, 480 V
△	3	-	1038812	HEATER ASSY, 8 kw, 415 V
	-	-	1038811	HEATER ASSY, 8 kw, 240 V
	-	-	103881	HEATER ASSY, 8 kw, 208 V
△	2	2	07128	GASKET
	1	1	104089	GENERATOR ASSY, WELD, SC 3.1 HL
ITEM		QTY.	PART NO.	DESCRIPTION
TOLERANCES (EXCEPT AS NOTED)				<b>CLEVELAND RANGE INC.</b> 1333 East 1791A St., Cleveland, Ohio 44110-2574
DECIMAL	± .030	SCALE	1/4" = 1"	
ANGULAR	± 1°	DRAWN BY	RICOS	APPROVED BY
				TITLE
				GENERATOR ASSEMBLY STEAMCRAFT 3.1, H.L.
CK	DATE	09-04-90	DRAWING NO.	C - 104090
				REV. G

LET.	REVISIONS	DATE	BY
A	REVISED NOTES PER E.O. . . . .	04-14-93	PJO
B	REDRAWN & REVISED PER EDIC-2400 R1	06-17-93	PJO
C	ADDED SC 5.1 GAS TIMER	08-02-93	PJO
D	P/N 106541 VAS 104716	11-04-93	DA

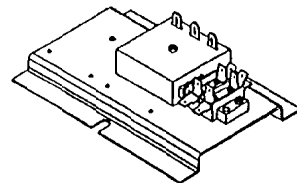
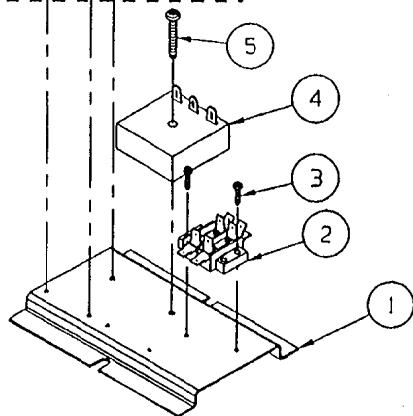
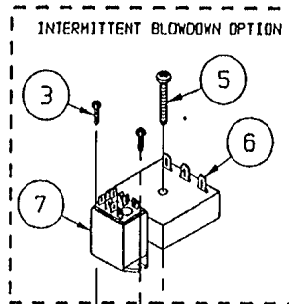

HEAT STANDBY ( STANDARD )

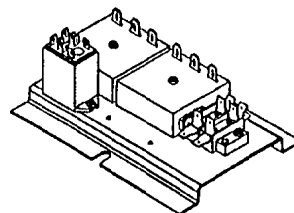

INTERMITTENT BLOWDOWN ( OPTIONAL )

TO POWER SWITCH  
( TO RELAY #5 IF INT. BLOWN. OPTION USED )

BLACK TO FLOAT

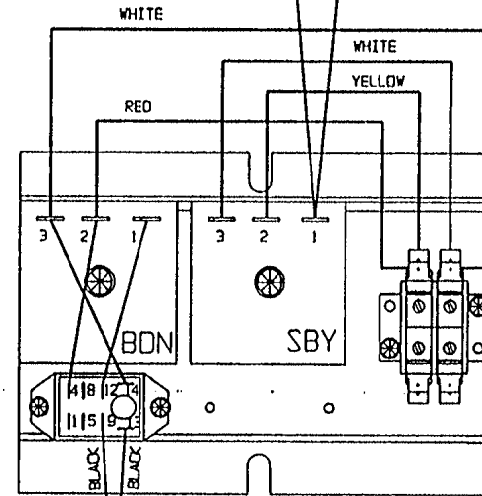

BLACK BELL TERMINAL ( P/N 100846 )

TO POWER SWITCH

NOTE:  
STANDBY TIMER WIRES TO STRAIGHT TABS ON TERMINAL  
INTERMITTENT TIMER WIRES TO 45° TABS ON TERMINAL

7	1	1	-	105966	RELAY, 120 V, DPDT
6	1	1	-	106541	TIMER, 1 MIN ON 0.8 SEC OFF
5	2	2	1	106124	SCREW, TORX/SLOT 10-32 X 1.00"
4	-	-	1	106580	TIMER, 20 SEC ON, 6 MIN. OFF
3	1	1	-	106247	TIMER, 2 SEC ON, 64 SEC OFF
2	4	4	2	106127	SCREW, TORX/SLOT 6-32 X 1/2"
1	1	1	1	44169	TERMINAL, BLOCK ASM, 2 POLE
1	1	1	1	106306	BRACKET, OPTION PLATE
ITEM	QTY.			PART NO.	DESCRIPTION

STEAMCRAFT 3.1	STEAMCRAFT 5.1	SC 5.1 GAS
----------------	----------------	------------

TOLERANCES (UNLESS NOTED)		CLEVELAND RANGE INC. 1333 East 179th St., Cleveland, Ohio 44110-2574	
DECIMAL ± N/A	SCALE 1/2"=1"	DRAWN BY DUTCHMAN	APPROVED BY
ANGULAR ± N/A	TITLE HEAT STANDBY PLATE WITH INTERMITTENT BLOWDOWN OPTION STEAMCRAFT 3.1 & 5.1		
CK	DATE 03-16-93	DRAWING NO. C - 106433	REV. 0

THIS DESIGN DESCRIBES A PROPRIETARY ITEM AND IS THE PROPERTY OF CLEVELAND RANGE. THIS DRAWING IS NOT TO BE COPIED OR USED WITHOUT THE APPROVAL OF CLEVELAND RANGE.

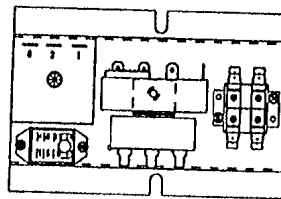
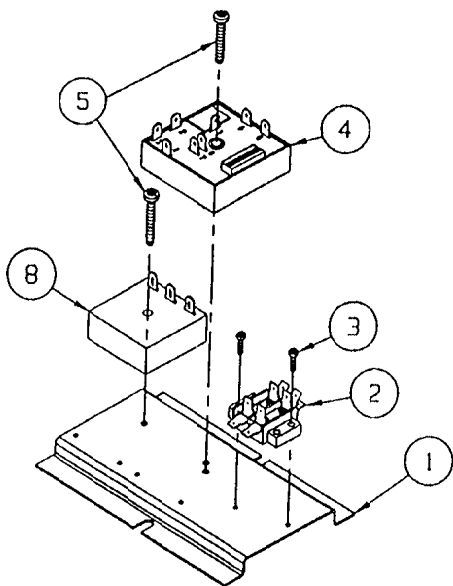
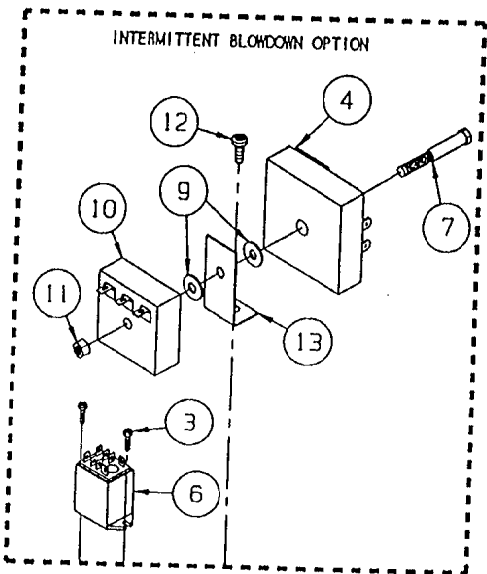

106433

INTERMITTENT BLOWDOWN ( OPTIONAL )

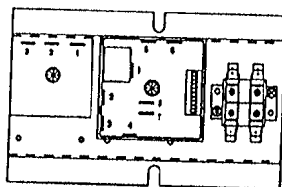

1064331

HEAT STANDBY ( STANDARD )

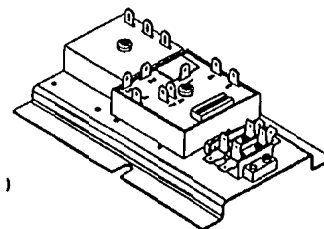
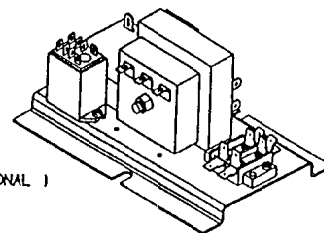

LET.	REVISIONS	DATE	BY
A	REVISED NOTES PER E.O. 1C-23.	04-14-93	PJD
B	REDRAWN & REVISED PER EOMC-2400 R1	08-17-93	PJD
C	ADDED SC 5.1 GAS TIMER	08-02-93	PJD
D	P/N 106541 WAS 104716	11-04-93	DFA
E	ADDED CONFIGURATION FOR CLEAN LIGHT AND REMOVED SC 5.1 GAS FROM B.O.M. PER E.O. 1C-2812	03-15-94	PJD
F	ROTATED TIMERS ON ASSEMBLY 106433 PER E.O. 1C-2732	11-29-94	PJD

△	13	-	1	105955	BRACKET, DUAL TIMER MOUNTING
△	12	-	1	106123	SCREW, TORX/SLOT #10-32 X .500" LG.
△	11	-	1	14818	NUT, HEX 1/4-20, FULL FINISH
△	10	-	1	106541	TIMER, 1 MIN. ON 0.8 SEC. OFF
△	9	-	2	23118	WASHER, FLAT 1/4-20 S/S
△	8	1	1	108247	INTERVAL TIMER, 2 SEC. ON, 64 SEC. OFF
△	7	-	1	106118	BOLT, 1/4-20 X 2-1/4, ZINC PLATED
	6	-	1	105966	RELAY, 120 V, DPDT
	5	2	1	106124	SCREW, TORX/SLOT #10-32 X 1.00" LG.
△	4	1	1	106911	TIMER, CLEAN LIGHT (DIP SWITCHES)
△	3	2	4	106127	SCREW, TORX/SLOT #6-32 X .500" LG.
	2	1	1	44168	TERMINAL, BLOCK ASM, 2 POLE
	1	1	1	106306	BRACKET, OPTION PLATE
	ITEM	QTY.		PART NO.	DESCRIPTION

1064331  
HEAT STANDBY

106433  
INT. BLOWDOWN

TOLERANCES  
(EXCEPT AS NOTED)

DECIMAL

± N/A

ANGULAR

± N/A

CK

SCALE

1/2" = 1"

DRAWN BY

DUTCHMAN

APPROVED BY

DATE

03-18-93

CLEVELAND RANGE INC.  
1333 East 179th St. Cleveland, Ohio 44110-2574

TITLE

HEAT STANDBY PLATE WITH

INTERMITTENT BLOWDOWN OPTION

STEAMCRAFT ULTRA 3 & 5 ELEC.

DRAWING NO.

C - 106433/106

REV.

F

THIS DESIGN DESCRIBES A PROPRIETARY ITEM AND IS THE PROPERTY OF CLEVELAND RANGE. THIS DRAWING IS NOT TO BE COPIED OR USED WITHOUT THE APPROVAL OF CLEVELAND RANGE.

LET.	REVISIONS	DATE	BY
------	-----------	------	----

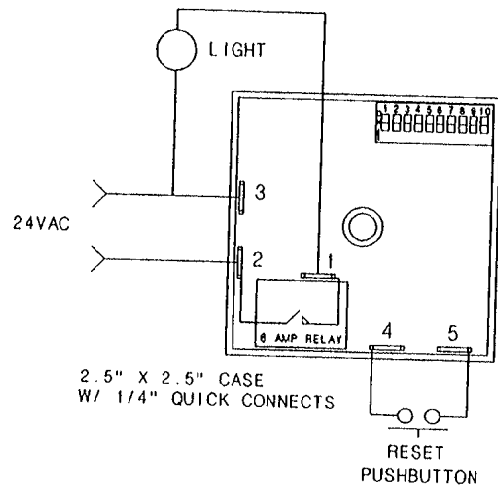

SWITCH #	TIME AMOUNT
1 =	0.5 HR
2 =	1.0 HR
3 =	2.0 HR
4 =	4.0 HR
5 =	8.0 HR
6 =	16.0 HR
7 =	32.0 HR
8 =	64.0 HR
9 =	128.0 HR
10 =	256.0 HR

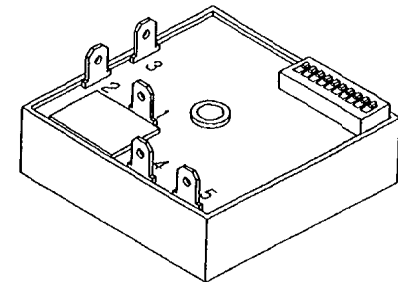

COMBINE SWITCHES FOR TIME DELAY IN HOURS  
EXAMPLES:

37 HRS = SWITCH 7 + SWITCH 4 + SWITCH 2  
250 HRS = SWITCH 9 + SWITCH 8 + SWITCH 7  
+ SWITCH 6 + SWITCH 5 + SWITCH 3

OPERATION:

SELECT DELAY VIA DIP SWITCH. APPLY 24VAC TO THE TIMER. AS THE SUPPLY VOLTAGE IS TURNED ON AND OFF TO THE TIMER THE TIMER WILL KEEP TRACK OF THE ELAPSED TIME THE SUPPLY VOLTAGE IS ON. ONCE THE TIMERS SUPPLY VOLTAGE HAS BEEN ON LONGER THAN THE SELECTED DELAY THE RELAY WILL TRANSFER. THIS IN TURN WILL TURN ON THE INDICATOR LIGHT. ONCE THIS HAS HAPPENED THE RESET BUTTON WILL BECOME ACTIVE AND ALLOW THE TIMER TO BE RESET.

SOURCE:  
AIROTRONICS  
2747 RT. 20 E. BOX 326  
CAZENOVIA, N.Y. 13035

TYPE: CR-2 TGCXB351IH5E2  
INPUT: 24 VAC. 6 AMP  
DELAY: 5-511. 5 HR. ON-DLY

THIS DESIGN DESCRIBES A PROPRIETARY ITEM  
AND IS THE PROPERTY OF CLEVELAND RANGE.  
THIS DRAWING IS NOT TO BE COPIED OR USED  
WITHOUT THE APPROVAL OF CLEVELAND RANGE.

ITEM	QTY.	PART NO.	DESCRIPTION
TOLERANCES (EXCEPT AS NOTED)		CLEVELAND RANGE INC. 1333 East 179th St. Cleveland, Ohio 44110-2574	
DECIMAL ± .030	SCALE 1=1	DRAWN BY DUTCHMAN	APPROVED BY
ANGULAR ± 1°	TITLE TIMER, CLEAN LIGHT (DIP SWITCHES)		
CK	DATE 05-23-94	DRAWING NO. B - 106911	REV. -

FOR ON/OFF SWITCH  
TIMER

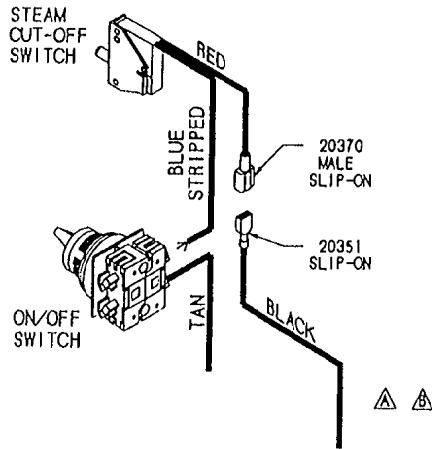

FROM: FLOAT (STANDARD)  
GEN. STAND-BY TIMER (SBY OPTION)  
BELL TERMINAL (TDS AND SBY OPTIONS TOGETHER)

FOR ELECTRICAL & 60 MINUTE  
MECHANICAL TIMERS

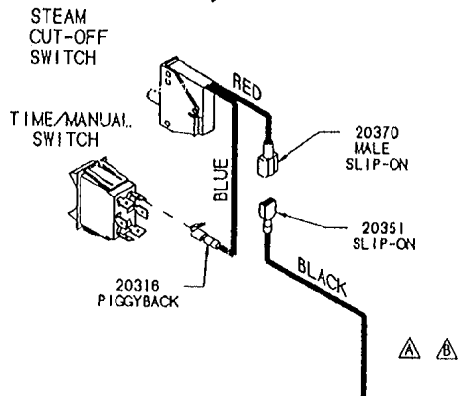

FROM: FLOAT (STANDARD)  
GEN. STAND-BY TIMER (SBY OPTION)  
BELL TERMINAL (TDS AND SBY OPTIONS TOGETHER)

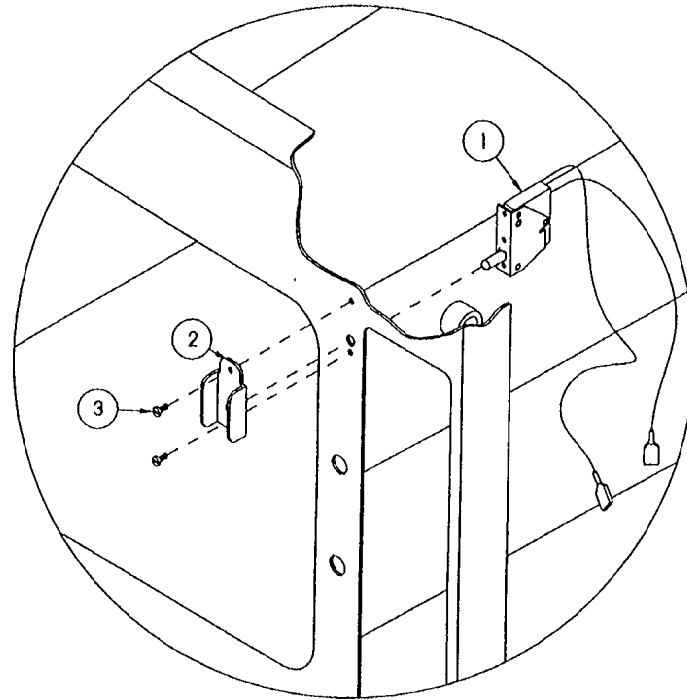

LET.	REVISIONS	DATE	BY
A	WAS: HIGH LIMIT NOW: FLOAT PER E.O. IC-2361 R1	03-01-93	PJD
B	20351 BLACK WAS FROM FLOAT ONLY PER EO IC-2361 R2	04-14-93	PJD

ITEM	QTY	PART NO.	DESCRIPTION
3	2	105449	SCREW, TRUSS HD. 6-32 X .312, S/S
2	1	105442	GUARD, SWITCH PROTECTION
1	1	104702	SWITCH, CMPT. STEAM SHUT-OFF

TOLERANCES (EXCEPT AS NOTED)		<b>CLEVELAND RANGE INC.</b> 1333 East 179th St. Cleveland, Ohio 44110-2574	
DECIMAL ± .030	SCALE N.T.S.	DRAWN BY DUTCHMAN	APPROVED BY
ANGULAR ± 1°	TITLE STEAM CUT-OFF OPTION STEAMCRAFT 3.1 AND 5.1		
CK	DATE 02-03-93	DRAWING NO. C - 10635F	REV. B

THIS DESIGN DESCRIBES A PROPRIETARY ITEM  
AND IS THE PROPERTY OF CLEVELAND RANGE.  
THIS DRAWING IS NOT TO BE COPIED OR USED  
WITHOUT THE APPROVAL OF CLEVELAND RANGE.

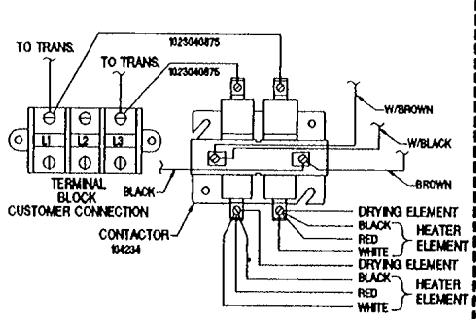
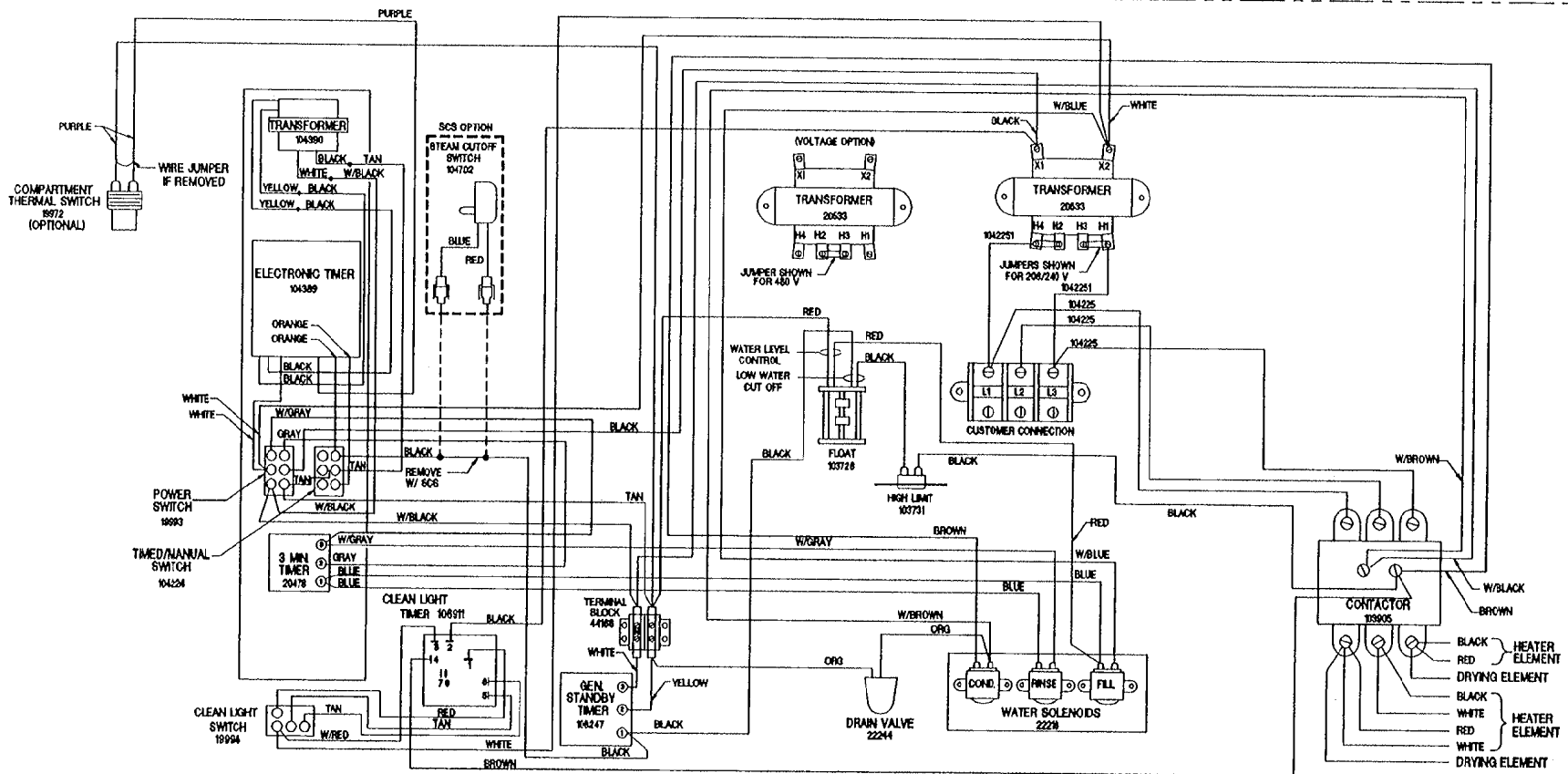

SINGLE PHASE WIRING CONFIGURATION

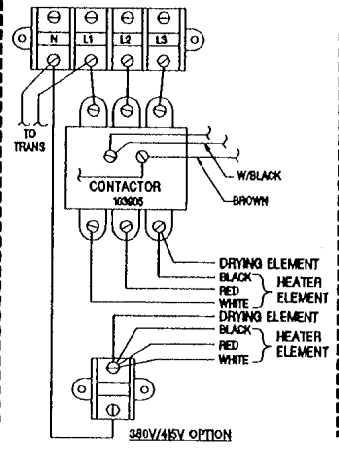

380V/465V OPTION

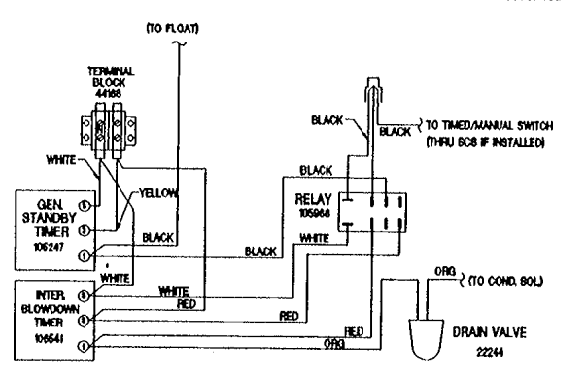

INTERMITTENT BLOWDOWN OPTION

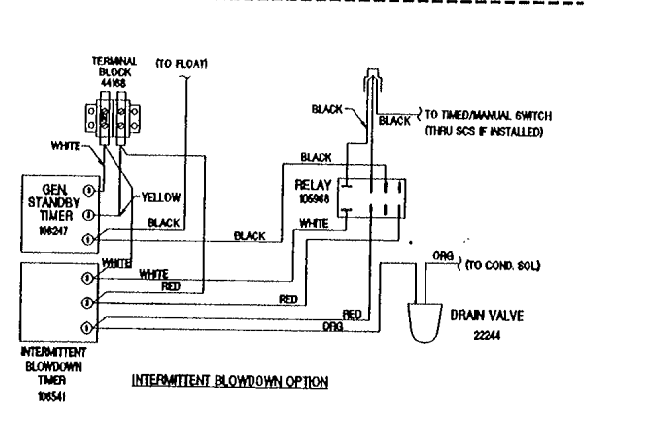
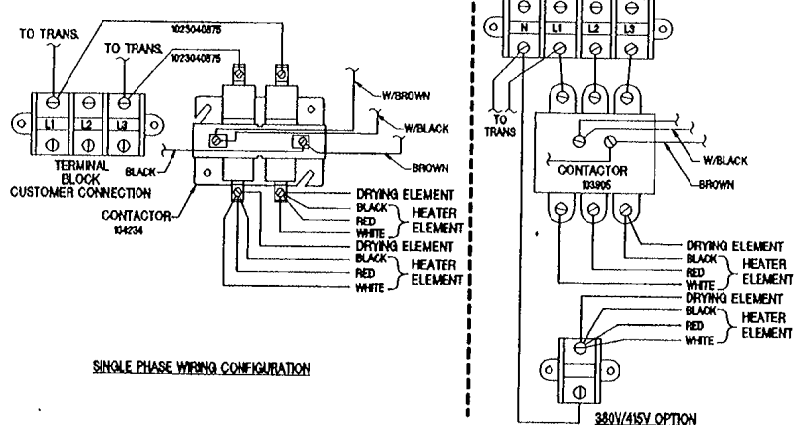
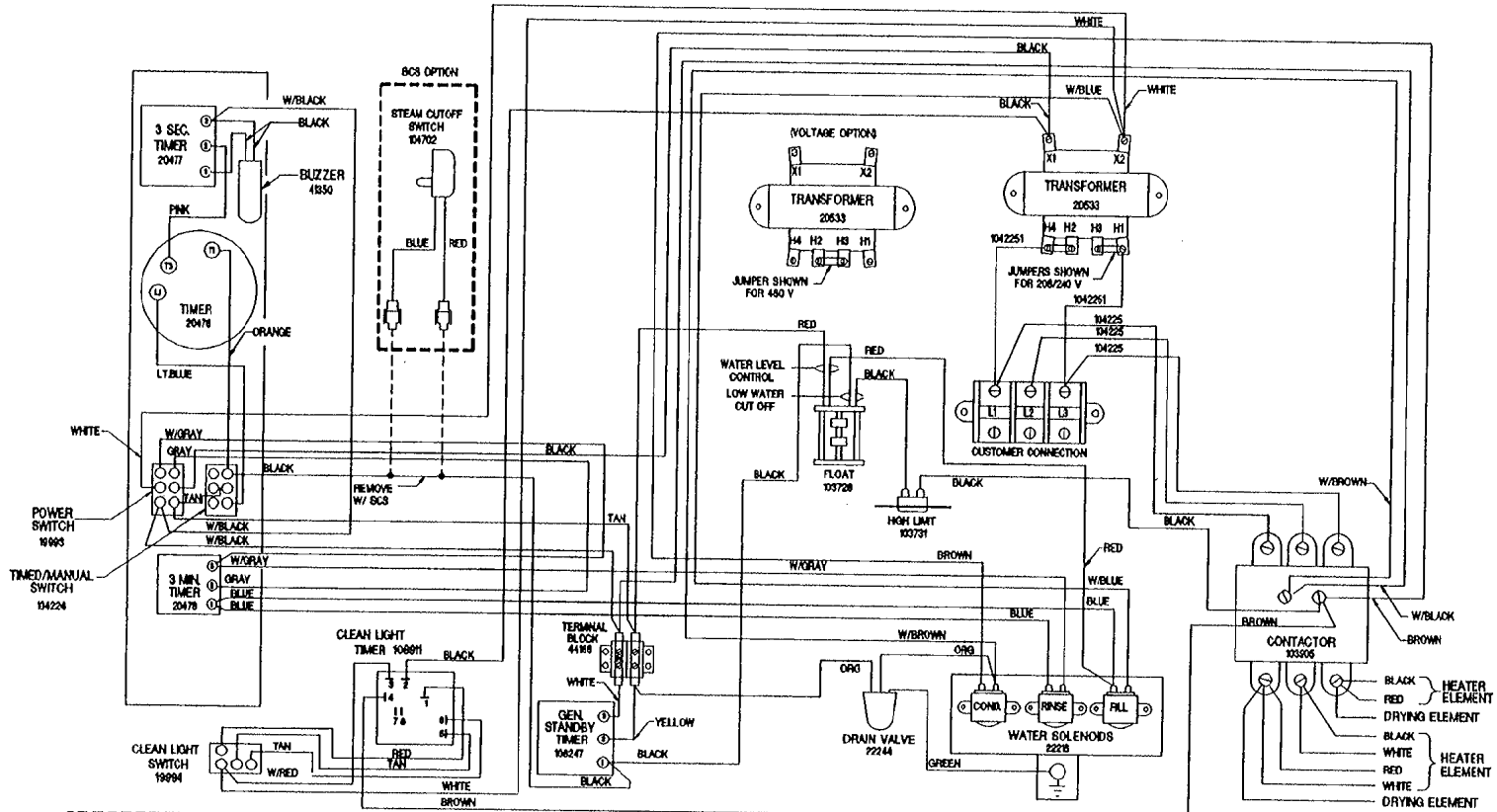

SINGLE PHASE WIRING CONFIGURATION

380V/415V OPTION

INTERMITTENT BLOWDOWN OPTION

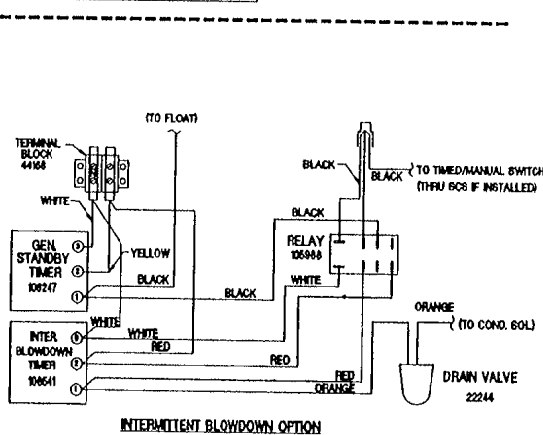
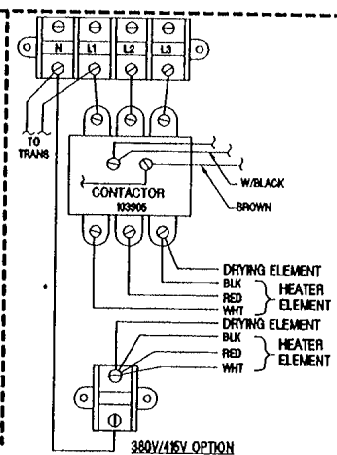
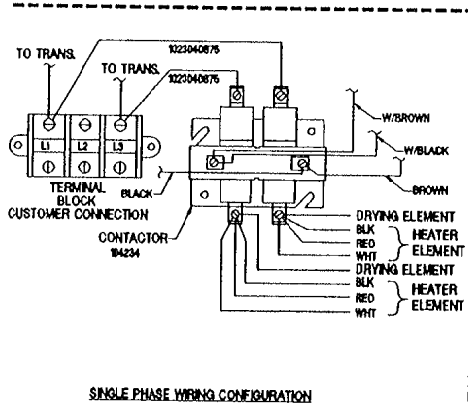
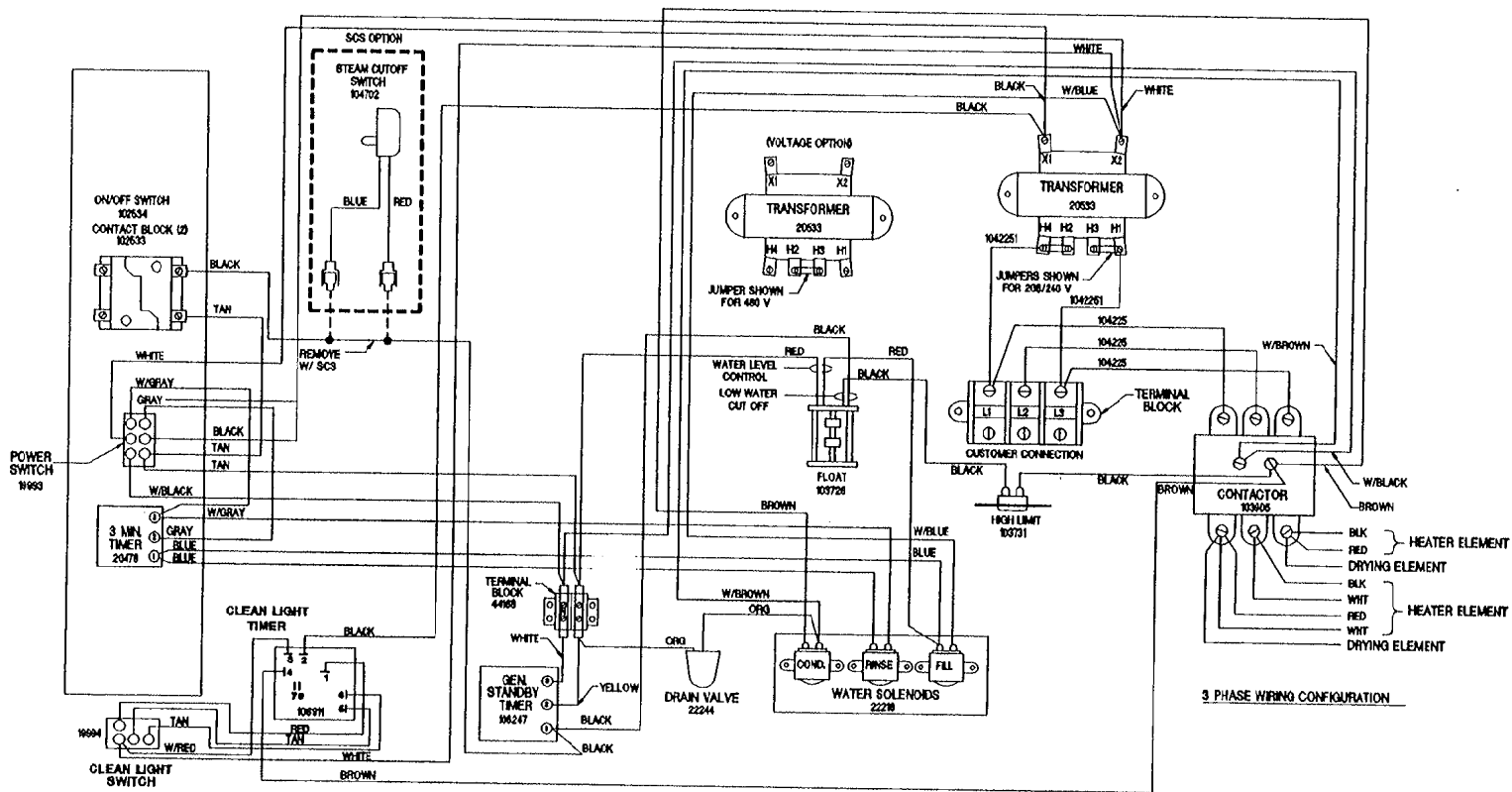

# CLEVELAND RANGE 21CET8 SEQUENCE OF OPERATIONS Mechanical Timer

1. Supply power is sent to the primary of the main transformer.
  - 115 VAC is sent from the secondary of the main transformer to the on/off rocker,
2. To turn the unit on, depress the red on/off rocker switch.
  - 115 VAC is sent to the red power light.
  - 115 VAC is sent to normally open drain valve closing it.
  - 115 VAC is sent to H and N on the water level board
3. With the water level board energized and no water in the generator
  - 5 seconds later 115 VAC is sent from the FILL terminal to the fill solenoid.
  - The fill solenoid opens and the generator fills through the drain valve.
  - The water fills to the low probe shorting it to ground
  - 115 VAC is sent to the heat standby timer which will energize 3 seconds every 4 minutes to maintain heat while unit is idle
  - 115 VAC is sent from the HEAT terminal to the timed manual switch.
4. When the timed/manual switch is in the timed position and time is on the timer
  - 115 VAC is sent from the timer to the R2 relay coil
    - R2 relay energizes closing the R2A and R2B contacts
    - 115VAC is sent through the now closed R2B contacts to the timer motor
    - 115 VAC is sent through the now closed R2A contacts through the door switch to the normally closed contacts of the high limit switch.
    - 115 VAC is then sent through the high limit to the coil of condensate solenoid
      - The condensate solenoid opens spraying cold water down the compartment drain.
    - 115 VAC is also sent through the high limit to the coil of the contactor.
    - 115 VAC is sent to the clean light timer.
      - When the clean light timer times down 115 VAC is sent to the clean light switch.
      - When the clean light switch is depressed the clean light timer is reset.
5. When the contactor coil is energized supply voltage is sent to both of the elements.
  - The elements are energized and the water is heated to steam.
  - Steam is directed to the cooking compartment.
6. When the timer times out
  - 115 VAC is sent to the 3 second timer and then to the buzzer for 3 seconds.
  - 115 VAC is removed from the R2 relay.
    - R2A contacts open de energizing the heat circuit
    - R22B relay contacts open removing the 115 VAC from the timer motor

7. When the water level reaches the high probe then 115 VAC is removed from the FILL terminal and the fill solenoid is turned off.
8. After the water level drops below the high probe for 5 seconds 115 VAC is sent to the FILL terminal again.
9. The red on/off switch is depressed and the unit is turned off.
  - 115 VAC is removed from the heat and timer circuit.
  - 115 VAC is removed from the normally open drain valve allowing the steamer to drain.
  - 115 VAC is sent to the 3-minute timer and the fill solenoid is energized for 3 minutes flushing the drain.

# STEAMCRAFT 3.1 MECHANICAL TIMER (PROBE)

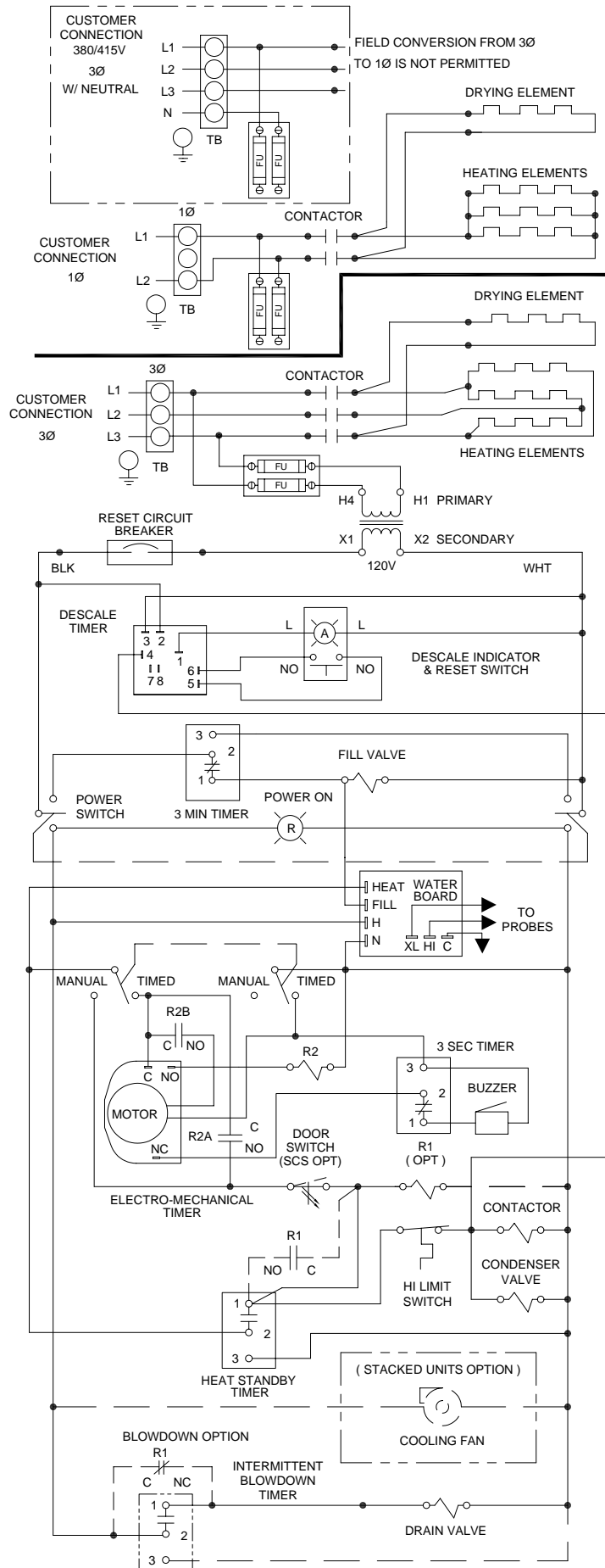

# STEAMCRAFT 3.1 MECHANICAL TIMER (PROBE)

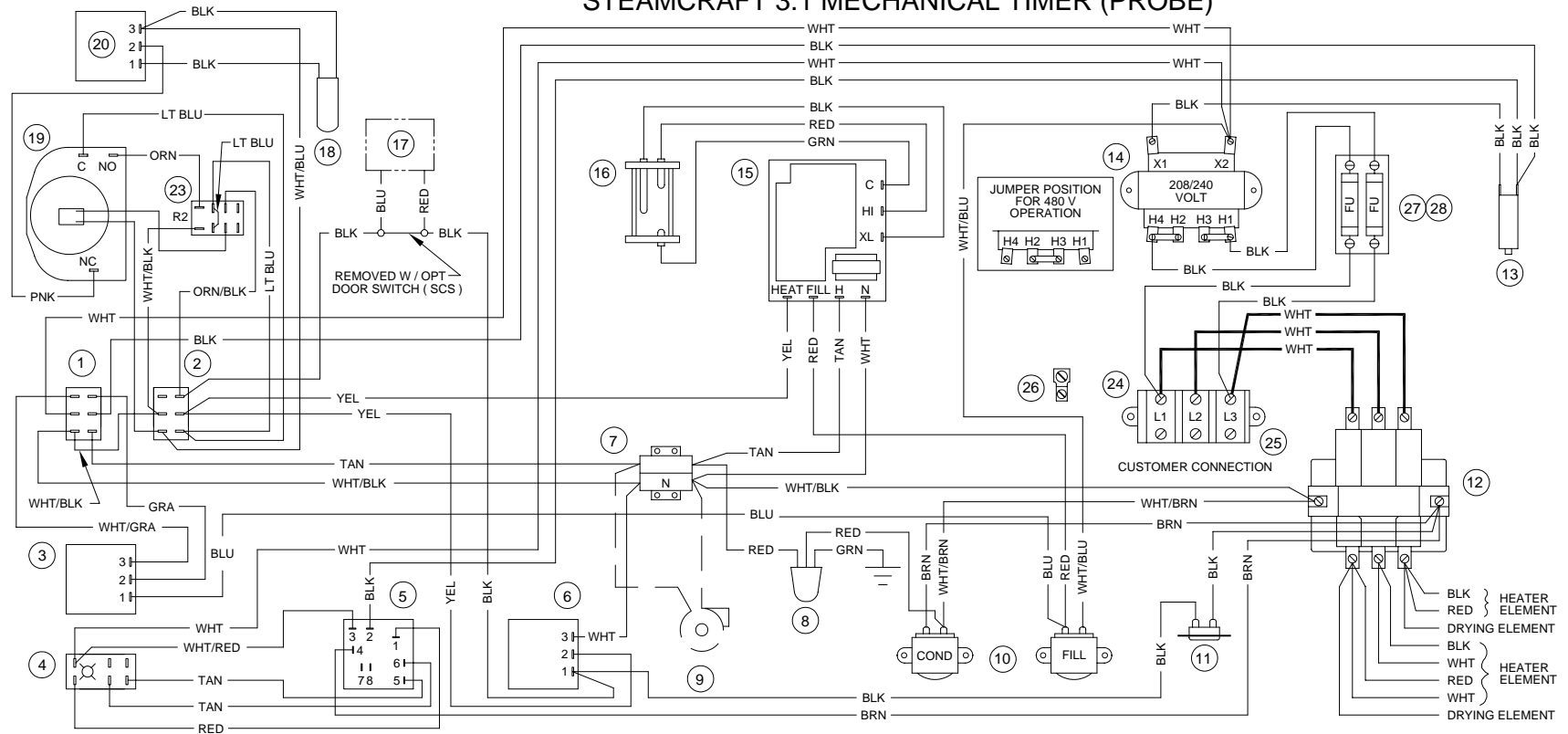

## SINGLE PHASE WIRING CONFIGURATION

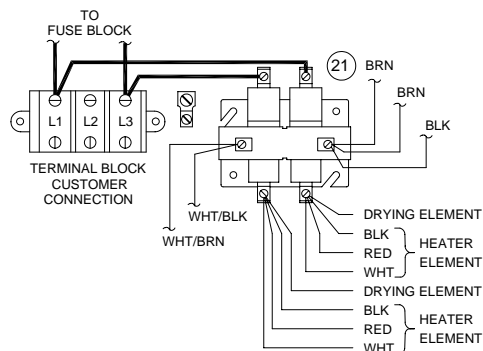

## INTERMITTENT BLOWDOWN OPTION

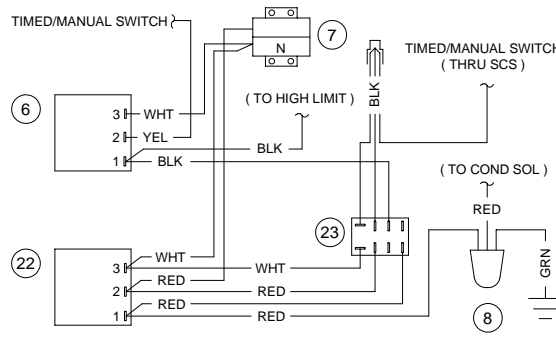

## PARTS LIST:

- |    |                                  |    |                               |
|----|----------------------------------|----|-------------------------------|
| 1  | 19993 - POWER SWITCH             | 17 | 108880 - DOOR SW ( MAGNETIC ) |
| 2  | 104224 - TIMED / MANUAL SW       | 18 | 41350 - BUZZER                |
| 3  | 20478 - 3 MIN TIMER              | 19 | 110198 - MOTORIZED TIMER      |
| 4  | 19994 - DESCALE IND RESET SWITCH | 20 | 20477 - 3 SEC TIMER           |
| 5  | 106911 - DESCALE TIMER           | 21 | 104234 - CONTACTOR            |
| 6  | 109239 - HEAT STANDBY TIMER      | 22 | 106541 - INTMT BLOWDOWN TIMER |
| 7  | 44168 - TERMINAL BLOCK           | 23 | 105966 - RELAY                |
| 8  | 22221 - DRAIN VALVE              | 24 | 101540 - END SEGMENT          |
| 9  | 107211 - COOLING FAN ( OPT )     | 25 | 101541 - TERM BLOCK SECTIONAL |
| 10 | 22218 - WATER SOLENOIDS          | 26 | 20304 - GROUND LUG            |
| 11 | 1103731 - HI LIMIT SWITCH        | 27 | 109380 - 3.5 AMP, 600V FUSE   |
| 12 | 300022 - CONTACTOR               | 28 | 109374 - FUSE BLOCK           |
| 13 | 108331 - RESET CIRCUIT BRKR      |    |                               |
| 14 | 20535 - TRANSFORMER              |    |                               |
| 15 | 107241 - WATER BOARD             |    |                               |
| 16 | 107239 - PROBE                   |    |                               |

**CLEVELAND RANGE 21CET8  
SEQUENCE OF OPERATIONS  
Electronic Timer**

1. Supply power is sent to the primary of the main transformer.
  - 115 VAC is sent from the secondary of the main transformer to the on/off rocker
2. To turn the unit on, depress the red on/off rocker switch.
  - 115 VAC is sent to the red indicator light.
  - 115 VAC is sent to normally open drain valve closing it.
  - 115 VAC is sent to H and N on the water level board
  - 115 VAC is sent to the 24VAC transformer for the electronic timer.
  - 115 VAC is sent to the normally open compartment thermostat switch.
3. With the water level board energized and no water in the generator
  - After a 5 second delay, 115 VAC is sent from the FILL terminal to the fill solenoid.
  - The fill solenoid opens and the generator fills through the drain valve.
  - The water fills to the low probe shorting it to ground
  - 115 VAC is sent from the HEAT terminal to the timed manual switch.
  - 115 VAC is sent to the heat standby timer which will energize 3 seconds every 4 minutes to maintain heat while unit is idle
4. When the timed/manual switch is in the timed position and time is on the timer
  - 115 VAC is sent from the timer through the optional door switch to the normally closed contacts of the high limit
  - 115 VAC is then sent through the high limit to the coil of condensate solenoid and the coil of the contactor.
  - 115 VAC is sent to the clean light timer.
  - When the clean light timer times down 115 VAC is sent to the clean light switch.
  - When the clean light switch is depressed the clean light timer is reset.
5. When the contactor is energized supply voltage is sent to both the Steam and Drying elements.
  - Steam is energized and sent to the cooking compartment.
  - When the cooking compartment reaches 193 degrees the compartment thermostat closes sending 115 VAC to the timer.
  - The timer will then begin counting down.
  - When the timer times down a buzzer will sound and the timer will open removing 115 VAC from the heat circuit.
6. When the water level reaches the high probe 115 VAC is removed from the FILL terminal and the fill solenoid is turned off.

7. After the water level drops below the high probe for 5 seconds 115 VAC is sent to the FILL terminal again.
8. The red on/off switch is depressed and the unit is turned off.
  - 115 VAC is removed from the timer and heat circuits.
  - 115 VAC is removed from the normally open drain valve allowing the steamer to drain.
  - 115 VAC is sent to the 3 minute timer and the fill solenoid is energized for 3 minutes flushing the drain.

# STEAMCRAFT 3.1 ELECTRONIC TIMER (PROBE)

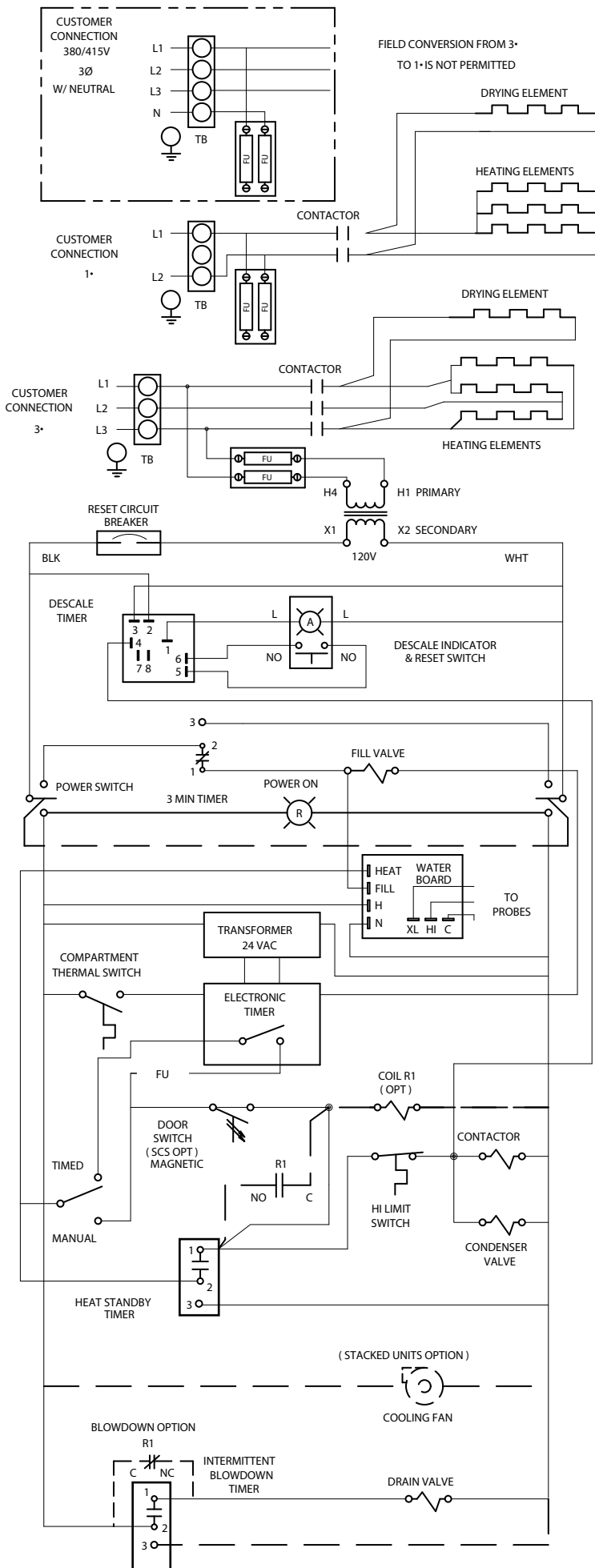

# STEAMCRAFT 3.1 ELECTRONIC TIMER (PROBE)

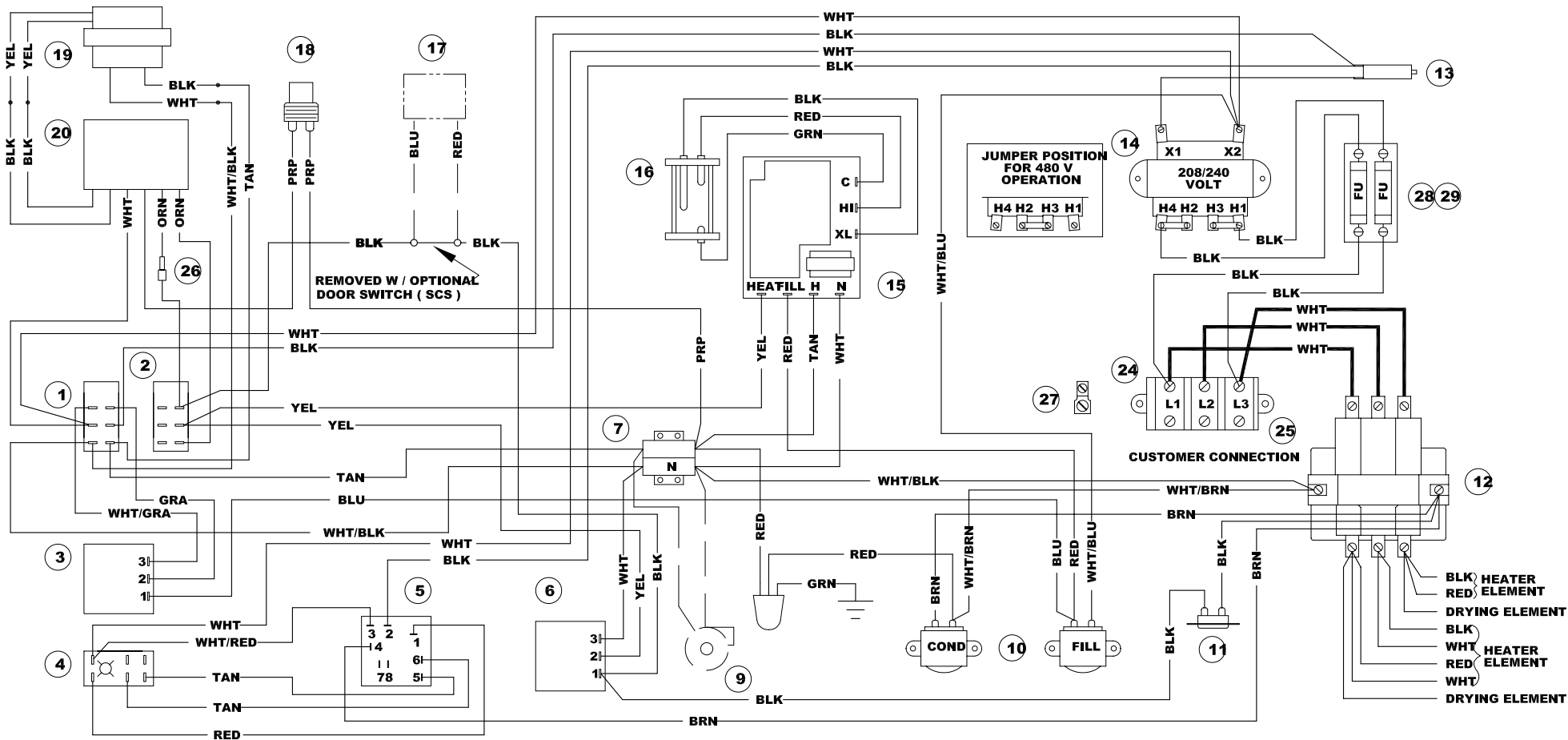

## SINGLE PHASE WIRING CONFIGURATION

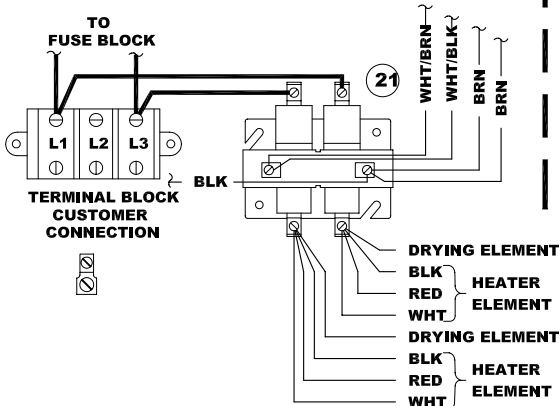

## INTERMITTENT BLOWDOWN OPTION

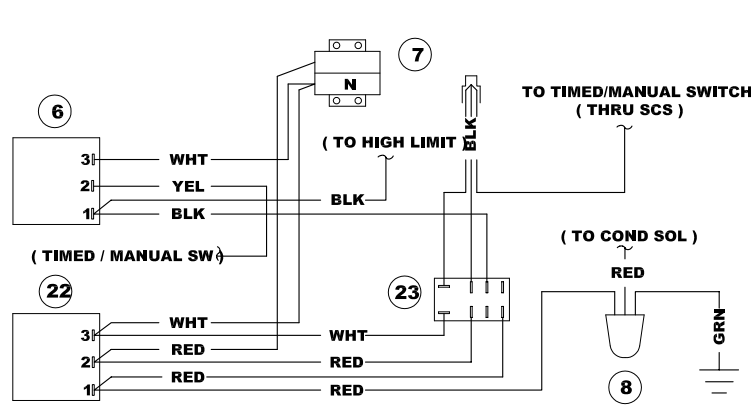

## PARTS LIST

- |                                |                                  |
|--------------------------------|----------------------------------|
| 1 19993 - POWER SWITCH         | 15 107241 - WATER BOARD          |
| 2 104224 - TIMED / MANUAL SW   | 16 107239 - PROBE                |
| 3 20478 - 3 MIN TIMER          | 17 108880 - DOOR SW ( SCS ) MAGN |
| 4 19994 - DESCALE IND RESET SW | 18 19972 - COMP THERMAL SW       |
| 5 106911 - DESCALE TIMER       | 19 104390 - TRANSFORMER          |
| 6 109239 - HEAT STANDBY TIMER  | 20 104389 - ELECTRONIC TIMER     |
| 7 44168 - TERMINAL BLOCK       | 21 104234 - CONTACTOR            |
| 8 22221 - DRAIN VALVE          | 22 106541 - INTMT BLOWDOWN TIMER |
| 9 107211 - COOLING FAN ( OPT ) | 23 105966 - RELAY                |
| 1022218 - WATER SOLENOIDS      | 24 101540 - END SEGMENT          |
| 11103731 - HI LIMIT SWITCH     | 25 101541 - TERM BLOCK SECTIONAL |
| 12300022 - CONTACTOR           | 26 106909 - 2 AMP, 250V FUSE     |
| 13108331 - RESET CIRCUIT BRKR  | 27 20304 - GROUND LUG            |
| 1420535 - TRANSFORMER          | 28 109380- 3.5 AMP, 600V FUSE    |
|                                | 29 109374 - FUSE BLOCK           |

**PROBLEM:**  
**21CET8**  
**21CET16**  
**21CEA10**  
**Steamer won't steam.**

**Steamer won't steam**

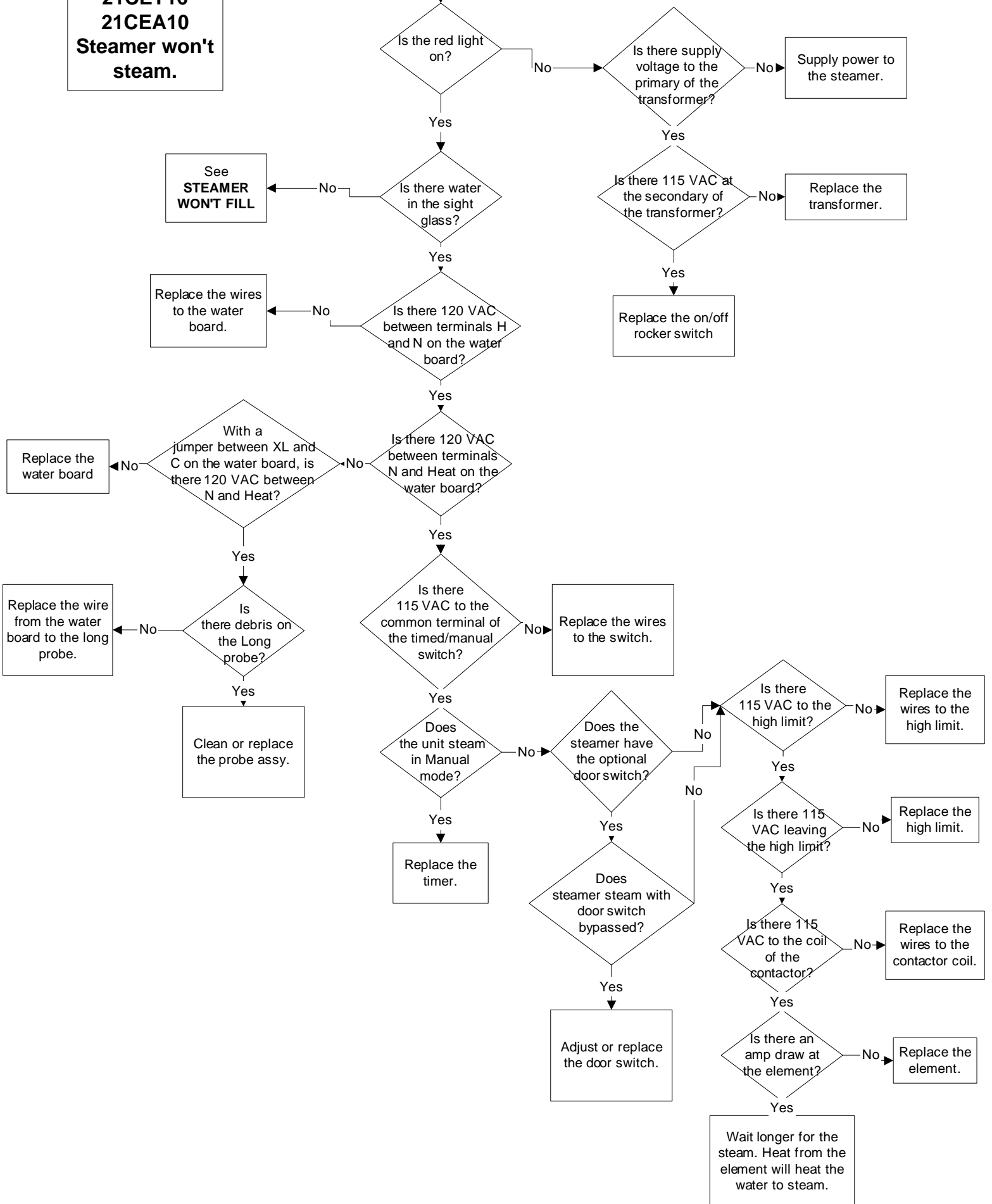

**PROBLEM:**  
**21CET8**  
**21CET16**  
**24CEA10**  
**Steamer wont fill**

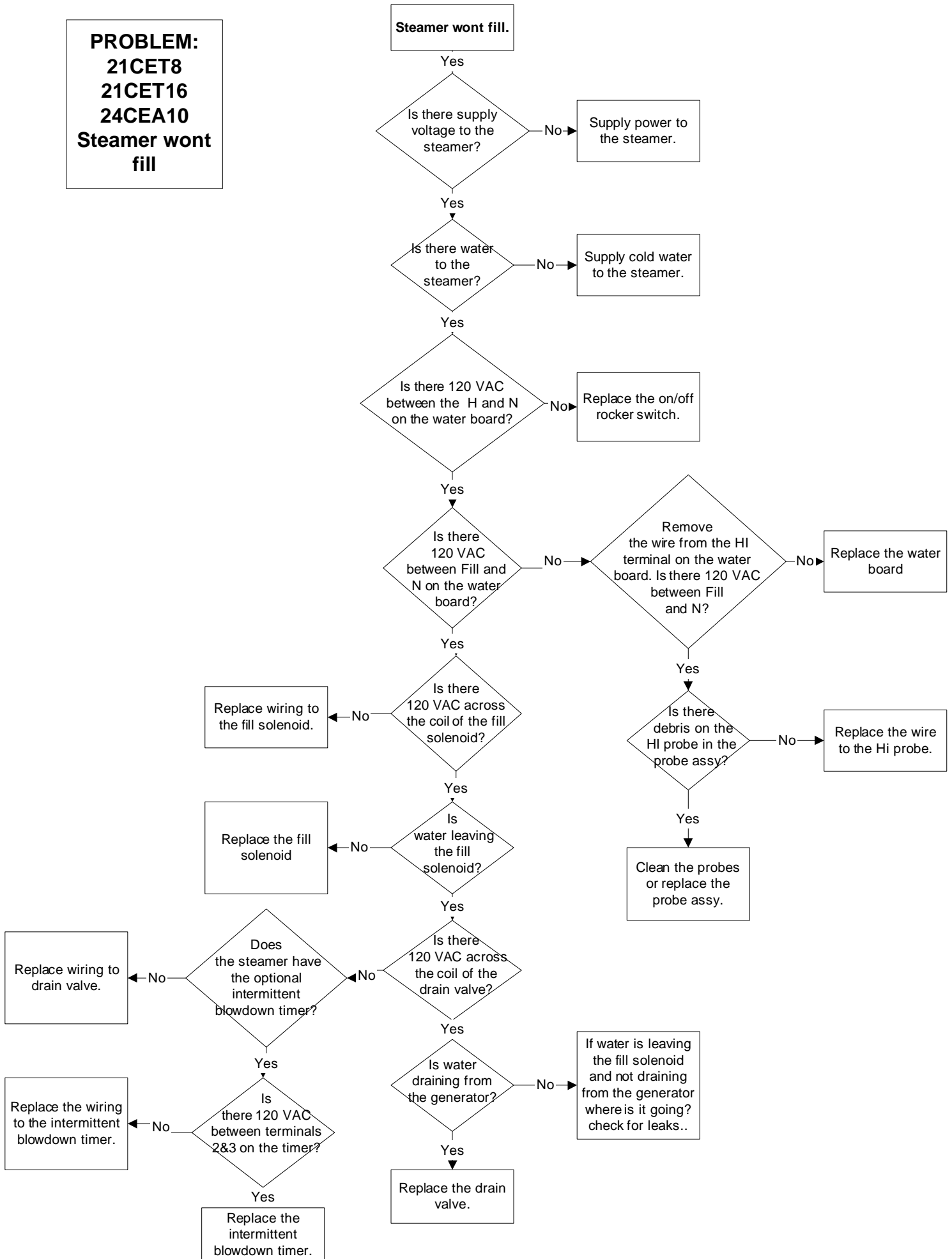

**PROBLEM:**  
**21CET8, 21CET16, 24CEA10**  
**Electronic timer displays "PAUS" and won't count down**

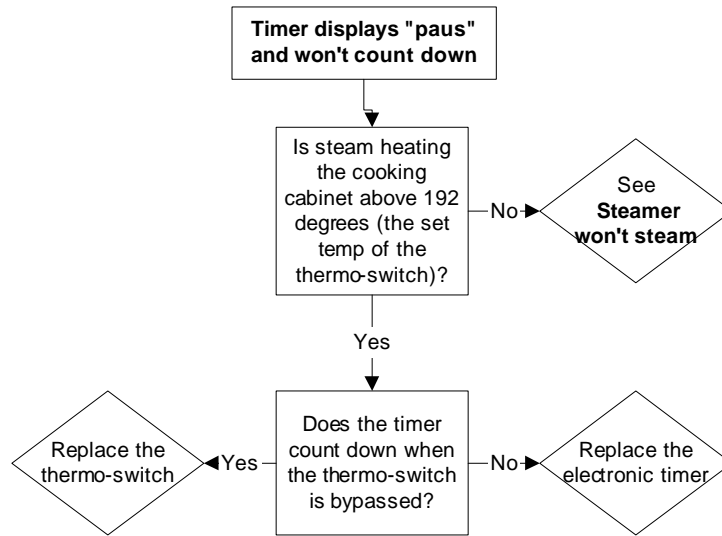

**PROBLEM:**  
**21CET8, 21CET16, 24CEA10**  
**Steam leaks around the door.**

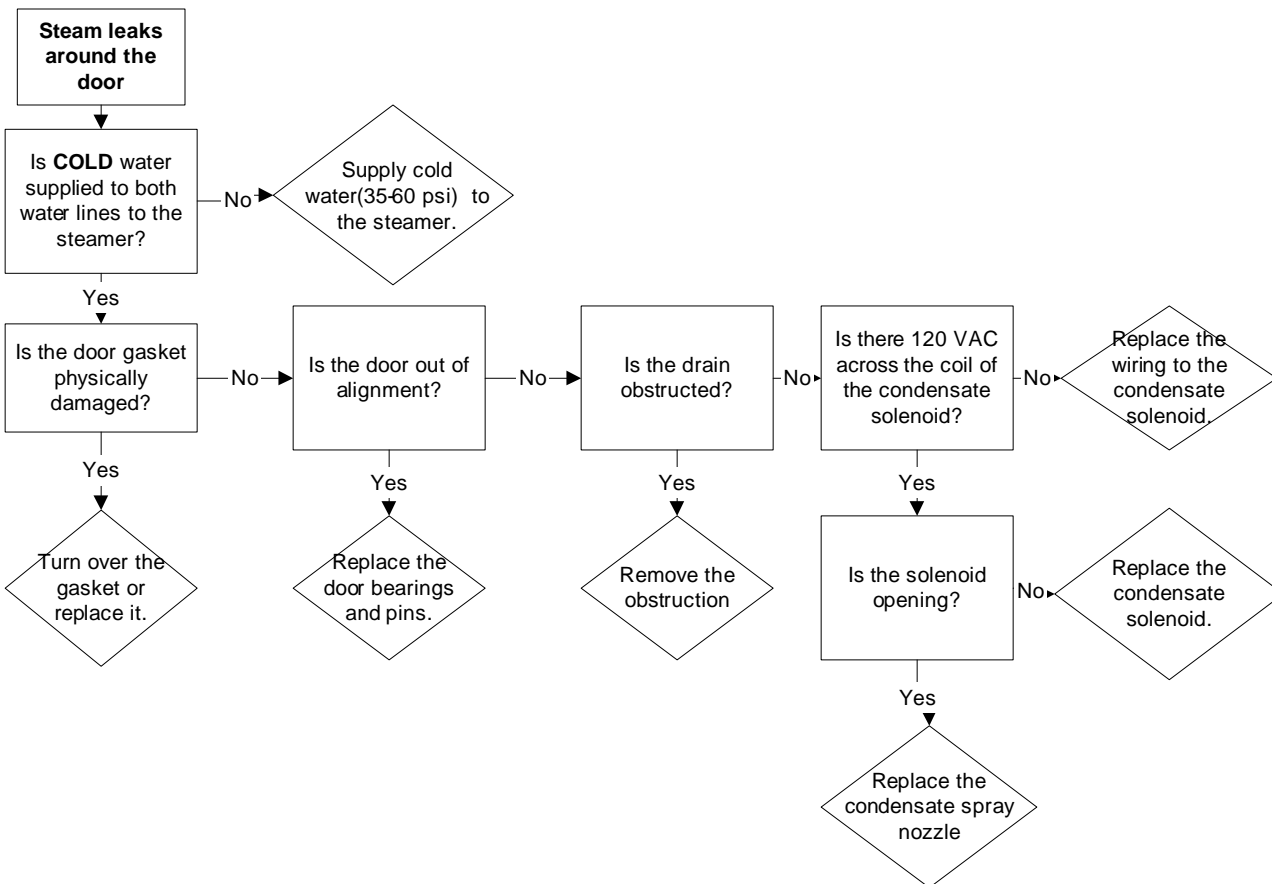

**PROBLEM:  
21CET8  
21CET16  
24CEA10  
Steamer overfills.  
(Water sprays into cooking cabinet)**

**Steamer overfills  
(Water sprays into the cooking cabinet)**

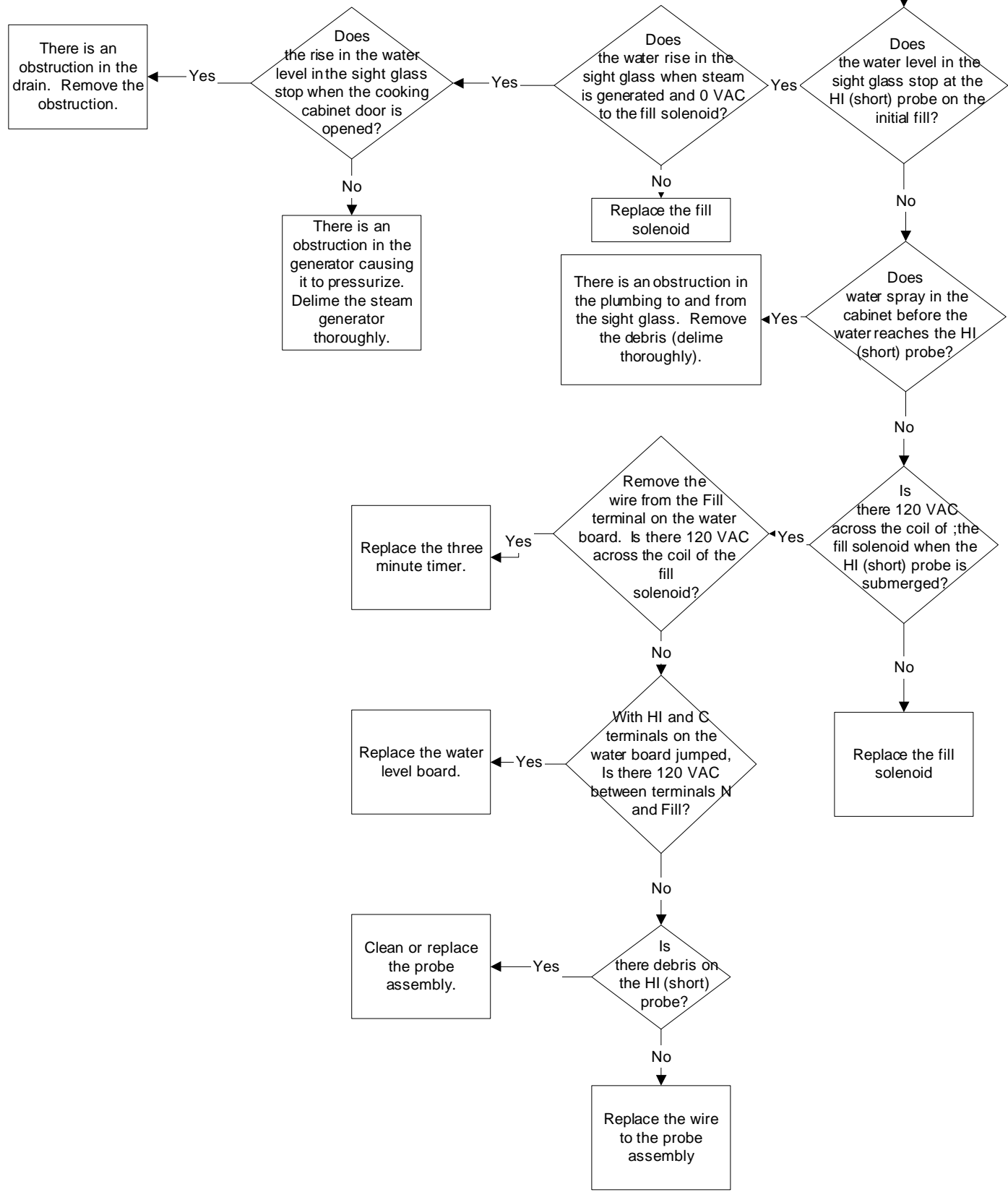

**PROBLEM:  
21CET8  
21CET16  
24CEA10  
Steamer won't stop steaming with  
door open**

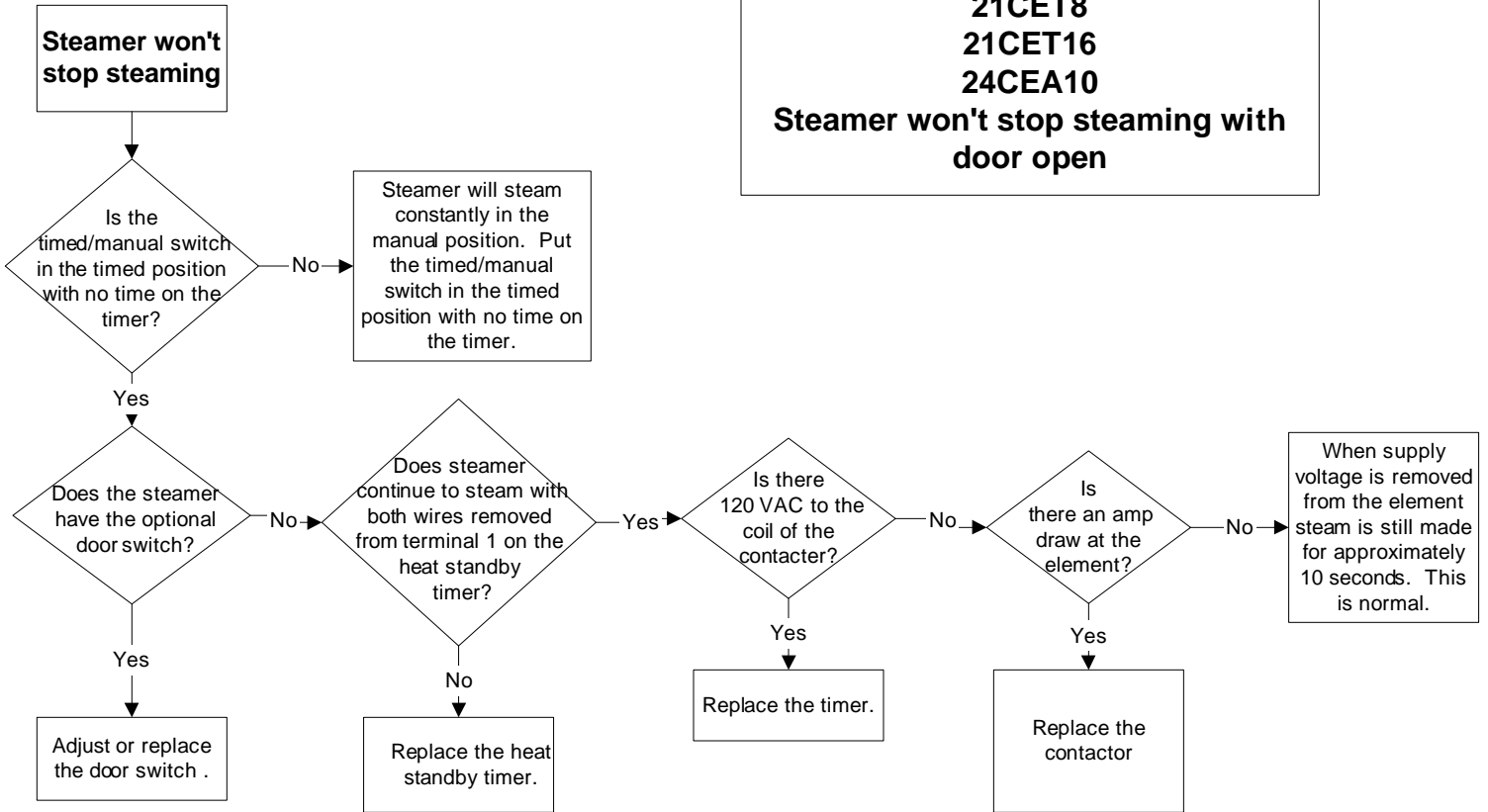

**Problem:  
21CET8, 24CEA10  
Steamer won't preheat**

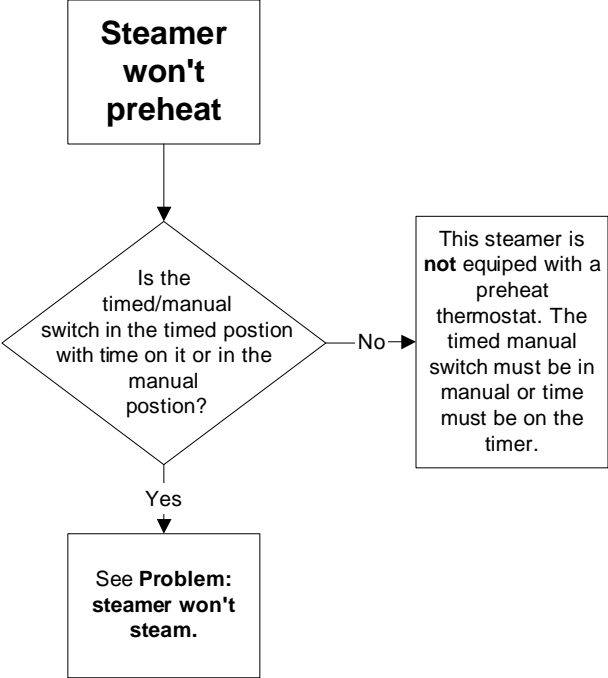

**Problem:  
21CET16  
Steamer won't preheat**

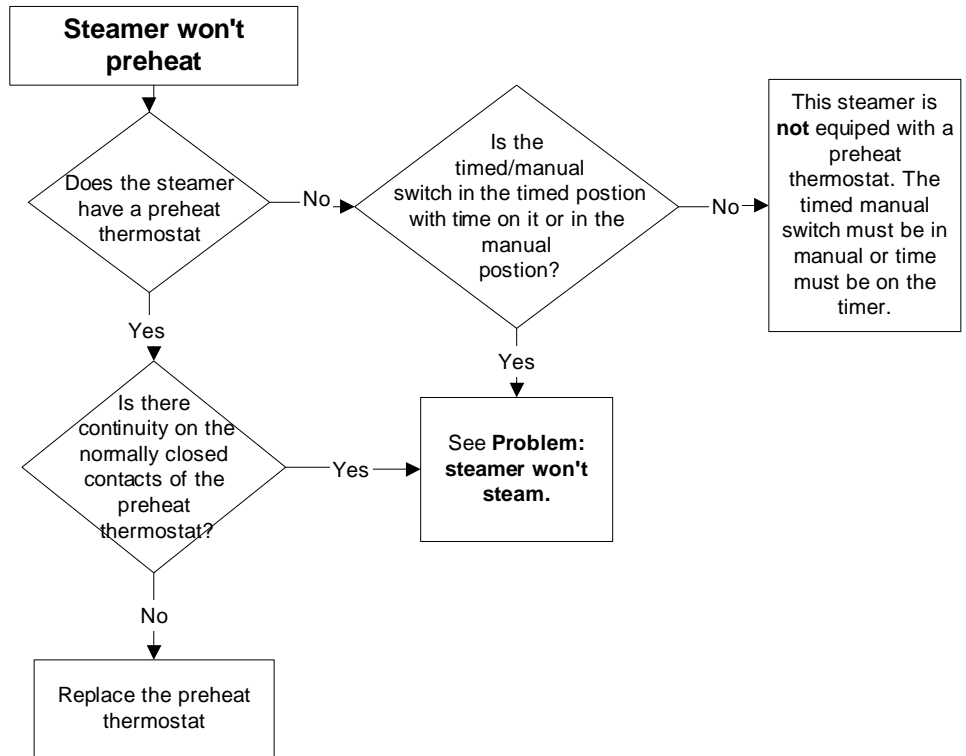

# STEAMCRAFT 3.1 MECHANICAL TIMER ( FLOAT )

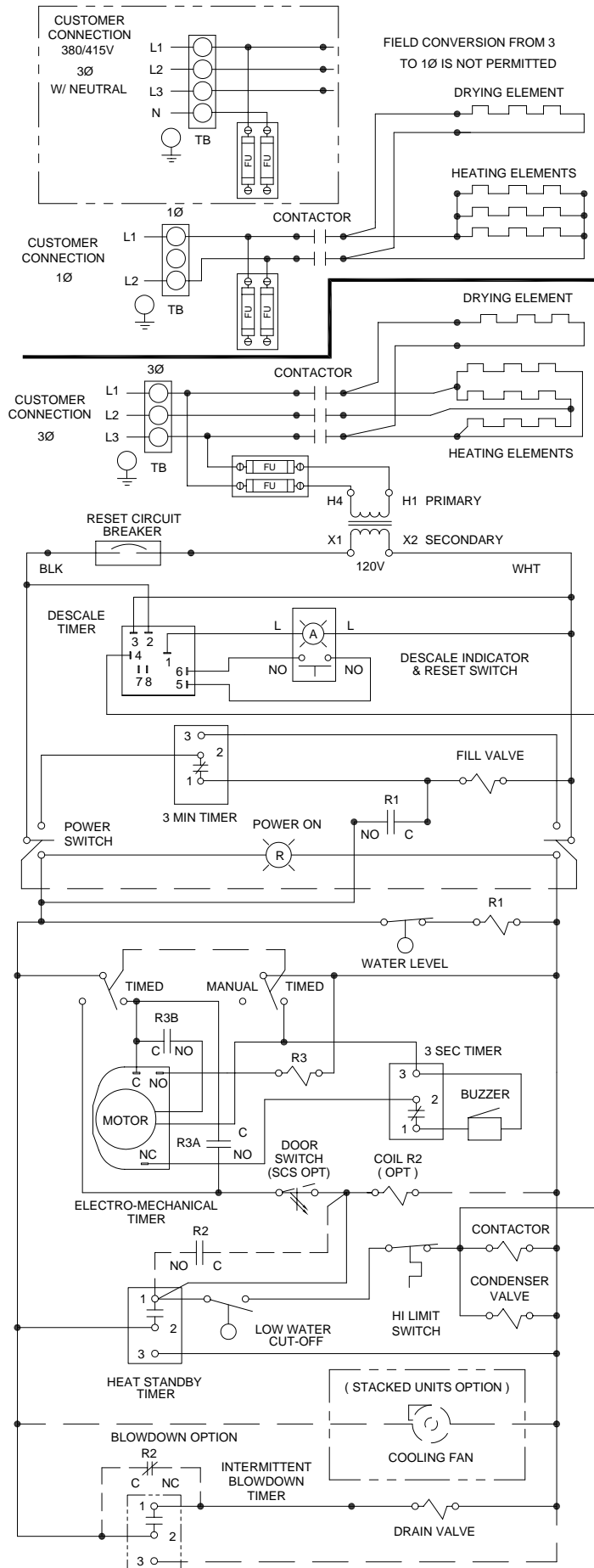

# STEAMCRAFT 3.1 MECHANICAL TIMER ( FLOAT )

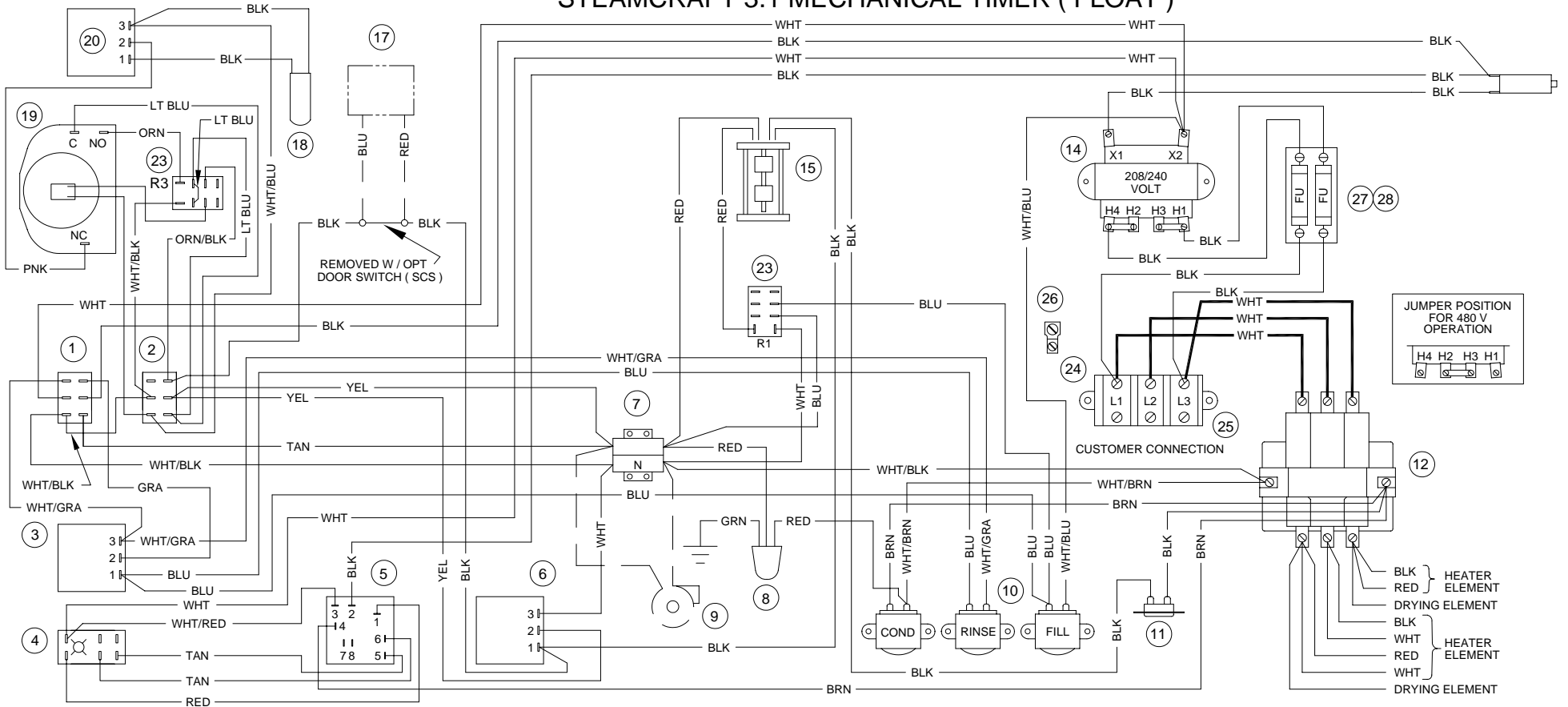

## SINGLE PHASE WIRING CONFIGURATION

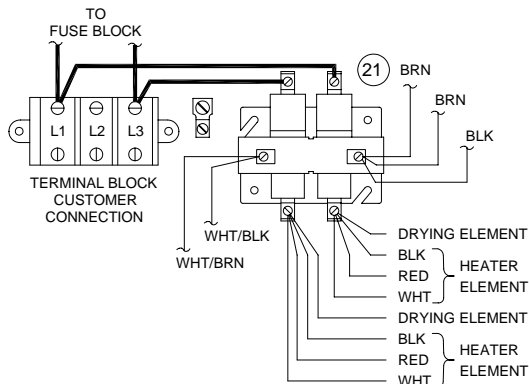

## INTERMITTENT BLOWDOWN OPTION

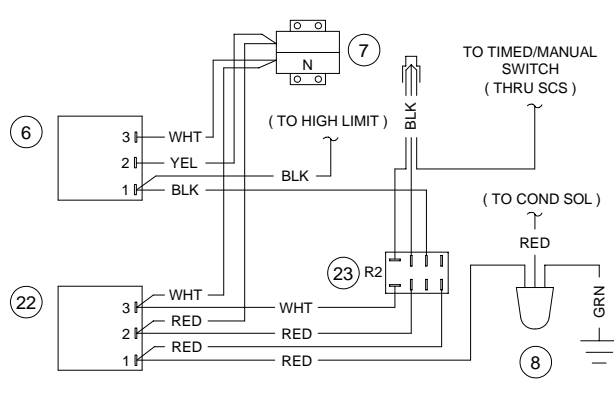

## PARTS LIST:

- |    |                                  |    |                               |
|----|----------------------------------|----|-------------------------------|
| 1  | 19993 - POWER SWITCH             | 17 | 108880 - DOOR SW ( MAGNETIC ) |
| 2  | 104224 - TIMED / MANUAL SW       | 18 | 41350 - BUZZER                |
| 3  | 20478 - 3 MIN TIMER              | 19 | 110198 - MOTORIZED TIMER      |
| 4  | 19994 - DESCALE IND RESET SWITCH | 20 | 20477 - 3 SEC TIMER           |
| 5  | 106911 - DESCALE TIMER           | 21 | 104234 - CONTACTOR            |
| 6  | 109239 - HEAT STANDBY TIMER      | 22 | 106541 - INTMT BLOWDOWN TIMER |
| 7  | 44168 - TERMINAL BLOCK           | 23 | 105966 - RELAY                |
| 8  | 22221 - DRAIN VALVE              | 24 | 101540 - END SEGMENT          |
| 9  | 107211 - COOLING FAN ( OPT )     | 25 | 101541 - TERM BLOCK SECTIONAL |
| 10 | 22218 - WATER SOLENOIDS          | 26 | 20304 - GROUND LUG            |
| 11 | 103731 - HI LIMIT SWITCH         | 27 | 109374 - FUSE BLOCK           |
| 12 | 300022 - CONTACTOR               | 28 | 109380 - FUSE 3.5A 600V       |
| 13 | 108331 - RESET CIRCUIT BRKR      |    |                               |
| 14 | 20535 - TRANSFORMER              |    |                               |
| 15 | 103726 - FLOAT                   |    |                               |
| 16 | -                                |    |                               |

# STEAMCRAFT 3.1 ON/OFF CONTROL (PROBE)

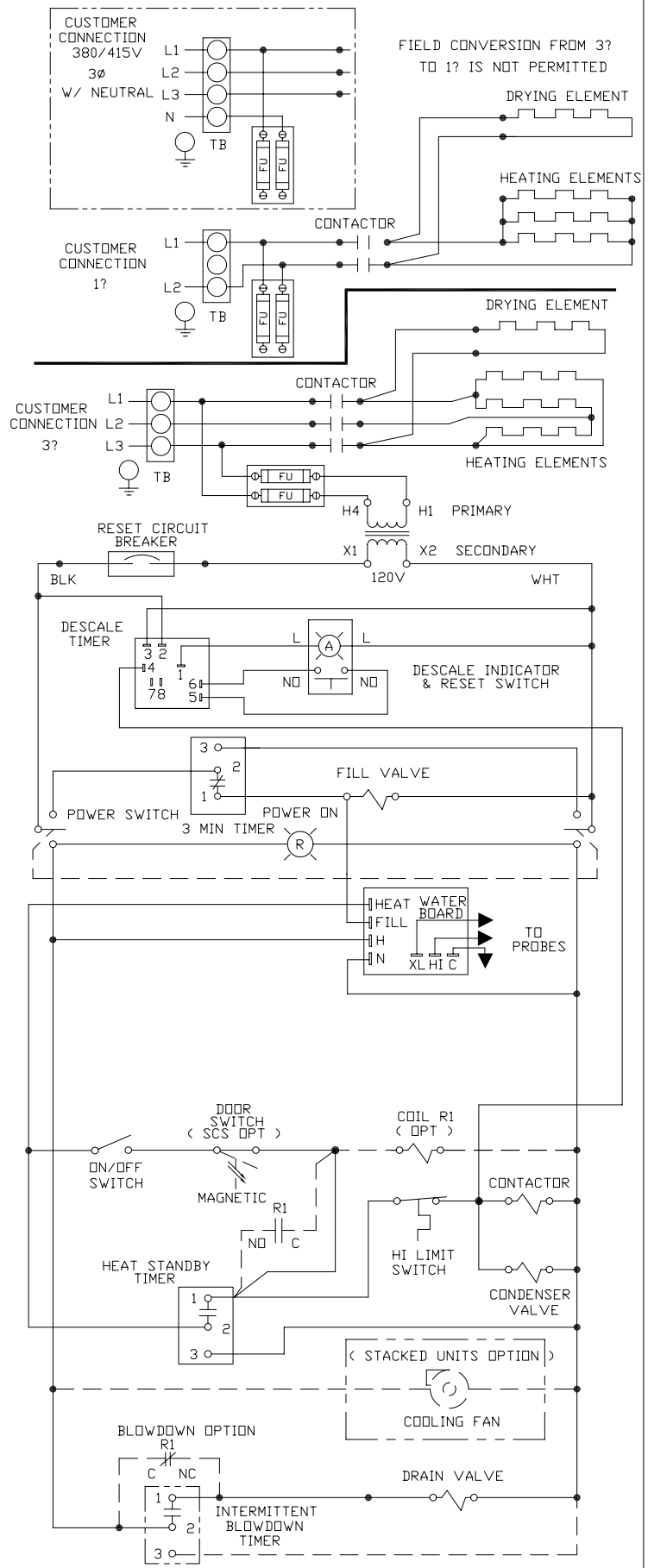

# STEAMCRAFT 3.1 ON/OFF SWITCH (PROBE)

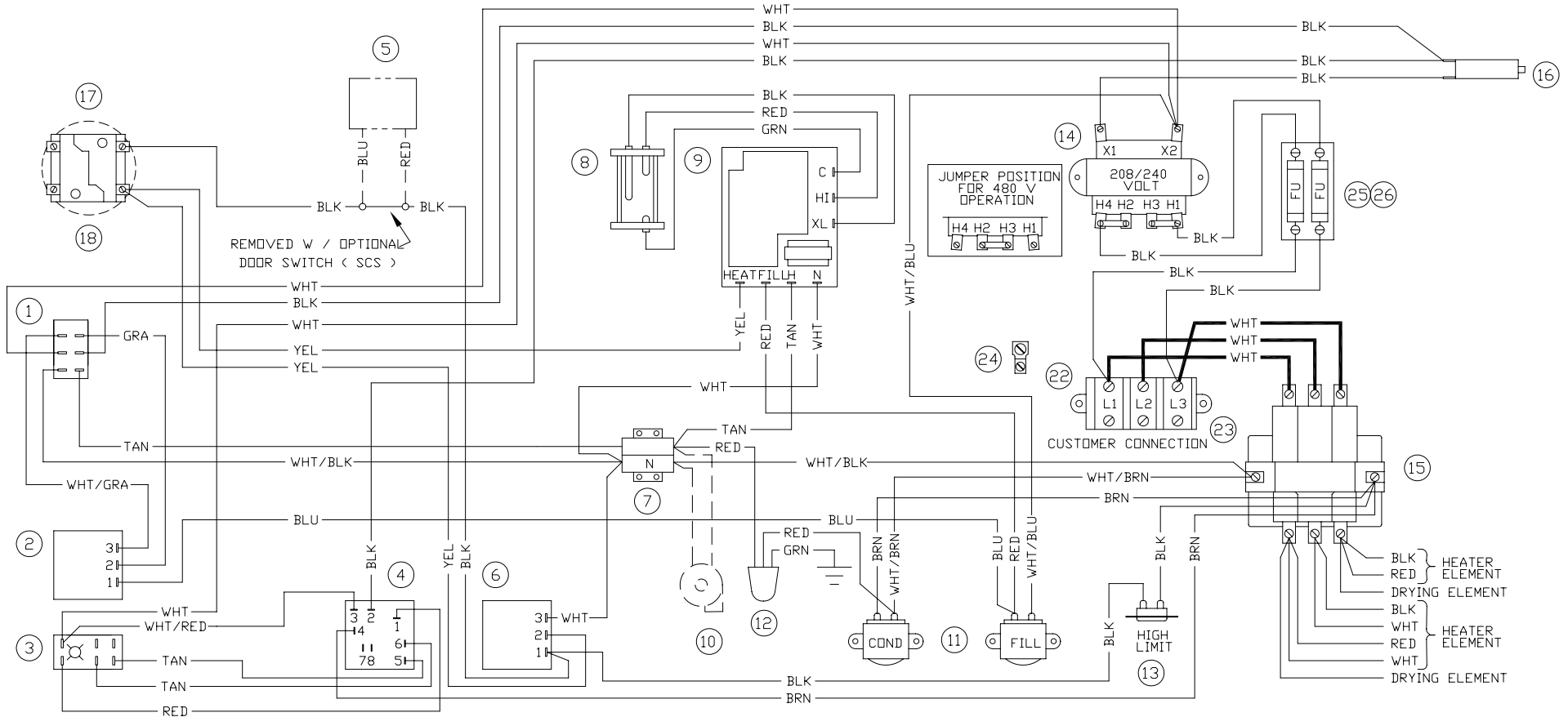

SINGLE PHASE WIRING CONFIGURATION

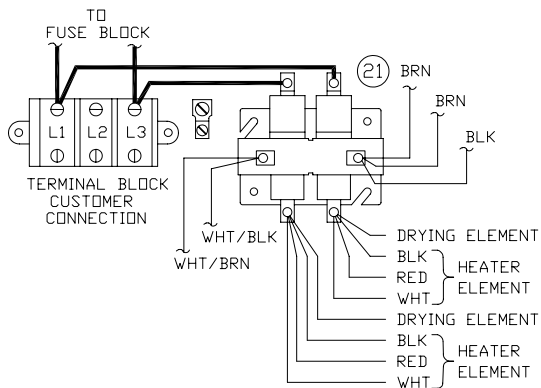

INTERMITTENT BLOWDOWN OPTION

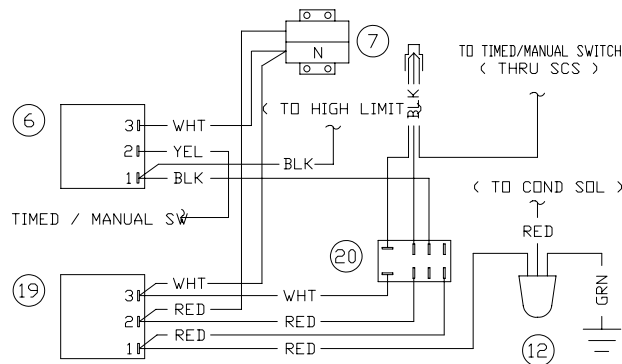

## PARTS LIST

- |                                    |                                  |
|------------------------------------|----------------------------------|
| 1 19993 - POWER SWITCH             | 17 102534 - ON / OFF SWITCH      |
| 2 20478 - 3 MIN TIMER              | 18 102533 - CONTACT BLOCK        |
| 3 19994 - DESCALE IND RESET SWITCH | 19 106541 - INTMT BLOWDOWN TIMER |
| 4 106911 - DESCALE TIMER           | 20 105966 - RELAY                |
| 5 108880 - DOOR SW (SCS) MAGNETIC  | 21 104234 - CONTACTOR            |
| 6 109239 - HEAT STANDBY TIMER      | 22 101540 - END SEGMENT          |
| 7 44168 - TERMINAL BLOCK           | 23 101541 - TERM BLOCK SECTIONAL |
| 8 107239 - PROBE                   | 24 20304 - GROUND LUG            |
| 9 107241 - WATERBOARD              | 25 109380 - 3.5 AMP, 600V FUSE   |
| 10 107211 - COOLING FAN (OPT)      | 26 109374 - FUSE BLOCK           |
| 11 22218 - WATER SOLENOID          |                                  |
| 12 22221 - DRAIN VALVE             |                                  |
| 13 103731 - HI LIMIT SWITCH        |                                  |
| 14 20535 - TRANSFORMER             |                                  |
| 15 300022 - CONTACTOR              |                                  |
| 16 108331 - RESET CIRCUIT BRKR     |                                  |

# STEAMCRAFT 3.1 / 5.1 MECHANICAL TIMER (PROBE)

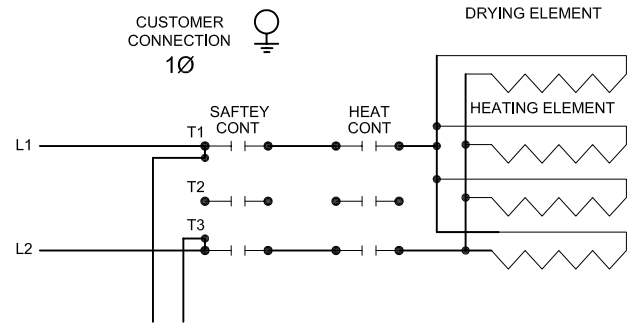
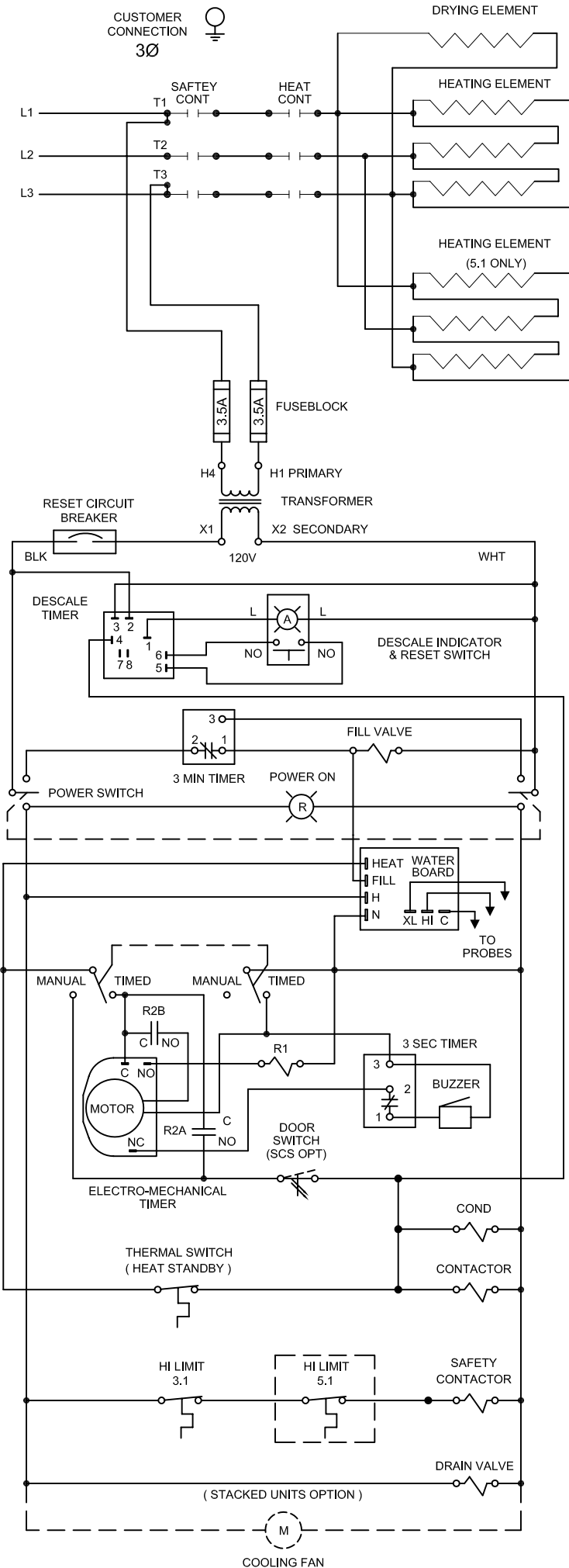

# STEAMCRAFT 3.1 / 5.1 MECHANICAL TIMER ( PROBE )

CUSTOMER CONNECT AT SAFETY CONTACTOR T1,2 & 3 FOR 3 Ø FOR 1 Ø ( 3.1 ONLY ) SEE SHEET 2

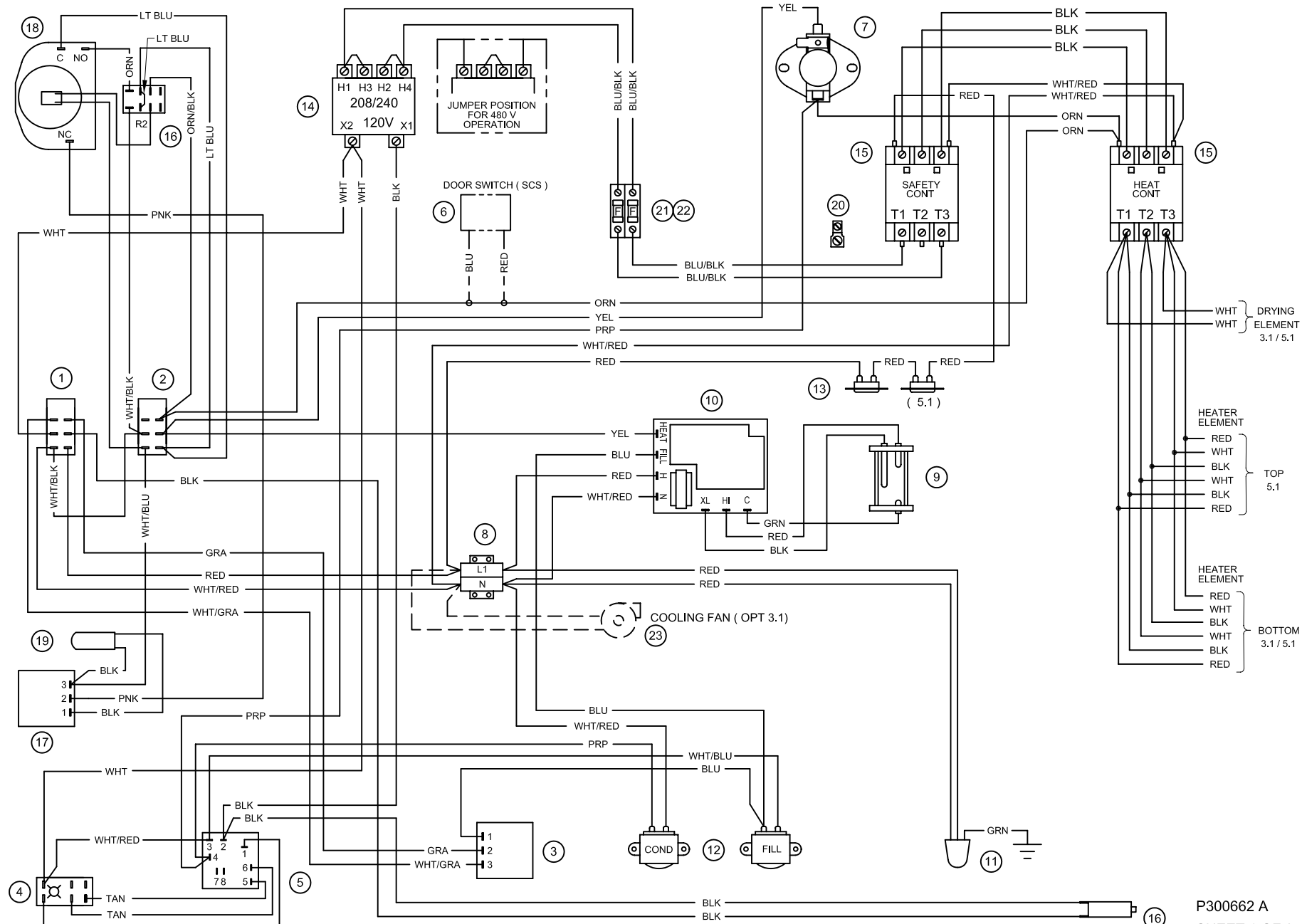

### PARTS LIST

1 19993 - POWER SWITCH	6 108880 - DOOR SW (MAGNETIC)	11 22221 - DRAIN VALVE	16 105966 - RELAY
2 104224 - TIMED/MANUAL SWITCH	7 105789 - THERMAL SWITCH ( HSB )	12 22218 - WATER SOLENOIDS	17 20477 - 3 SEC TIMER
3 20478 - 3 MIN TIMER	8 44168 - TERMINAL BLOCK	13 103731 - HI LIMIT SWITCHES	18 110198 - MOTORIZED TIMER
4 19994 - DESCALE INDICATOR RESET SW	9 107239 - PROBE	14 20535 - TRANSFORMER	19 41350 - BUZZER
5 106911 - DESCALE TIMER	10 107241 - WATER BOARD	15 03509 - CONTACTORS	20 20304 - GROUND LUG
			21 109374 - FUSE BLOCK
			22 109380 - FUSE, 3.5A
			23 107211 - COOLIN FAN (OPT 3.1)

REV.	DATE	BY
A	5-12-19	VOS

REVISED FOR PRODUCTION RELEASE ECR-0419

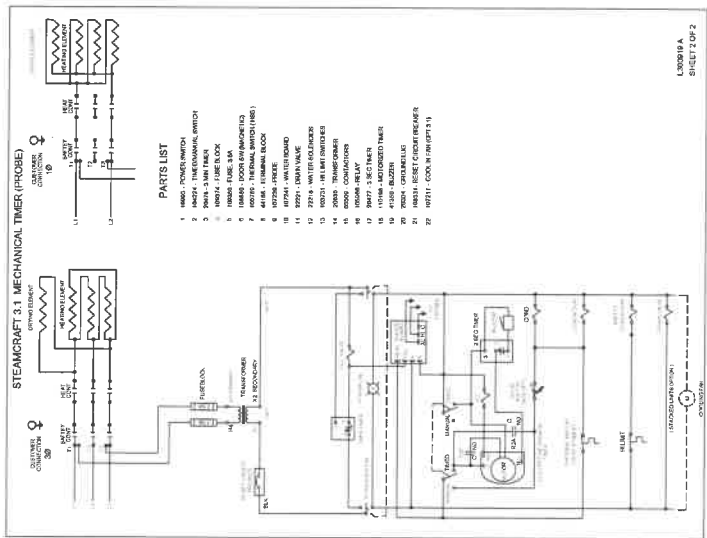
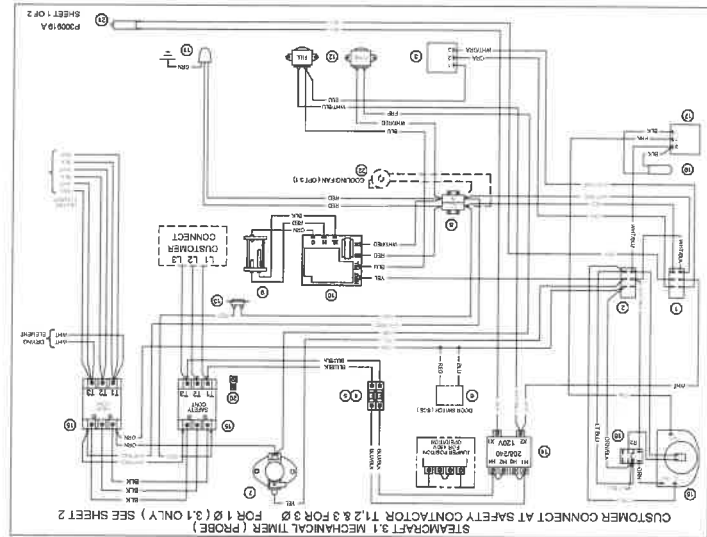

PARTS LIST

- 1 1800V POWER SWITCH
- 2 1800V FUSE BLOCK
- 3 1800V FUSE
- 4 1800V FUSE BLOCK
- 5 1800V FUSE BLOCK
- 6 1800V FUSE BLOCK
- 7 1800V FUSE BLOCK
- 8 1800V FUSE BLOCK
- 9 1800V FUSE BLOCK
- 10 1800V FUSE BLOCK
- 11 1800V FUSE BLOCK
- 12 1800V FUSE BLOCK
- 13 1800V FUSE BLOCK
- 14 1800V FUSE BLOCK
- 15 1800V FUSE BLOCK
- 16 1800V FUSE BLOCK
- 17 1800V FUSE BLOCK
- 18 1800V FUSE BLOCK
- 19 1800V FUSE BLOCK
- 20 1800V FUSE BLOCK
- 21 1800V FUSE BLOCK
- 22 1800V FUSE BLOCK
- 23 1800V FUSE BLOCK
- 24 1800V FUSE BLOCK
- 25 1800V FUSE BLOCK
- 26 1800V FUSE BLOCK
- 27 1800V FUSE BLOCK

NOTES: 1. SEE PARTS LIST FOR PARTS LIST  
2. TO BE PRINTED ON 8 1/2 X 11 LABEL PRINTED PAPER (4875)

REV	DATE	BY
D	5-12-19	VOS

REVISED FOR PRODUCTION RELEASE ECR-0419

STEAMCRAFT 3.1 MECHANICAL TIMER (PROBE)

WIRING DIAGRAMS

3.100

3.1

300919

3.1

# STEAMCRAFT 3.1 / 5.1 ELECTRONIC TIMER (PROBE)

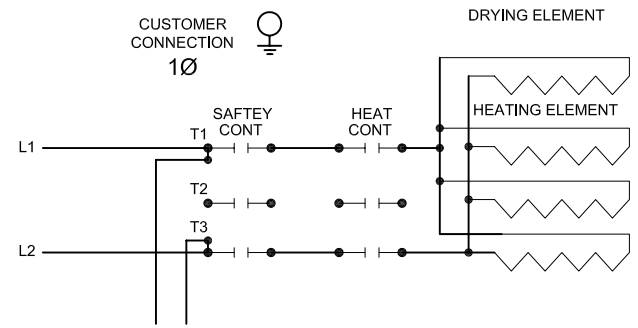
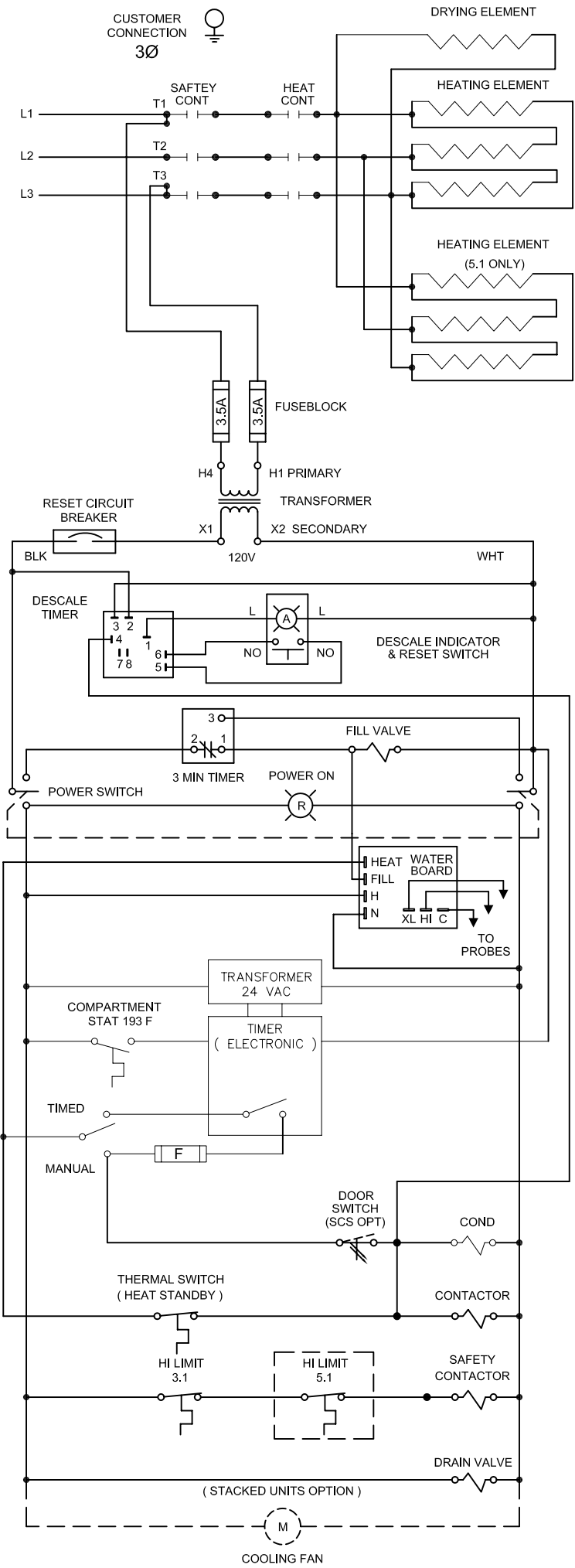

# STEAMCRAFT 3.1 / 5.1 ELECTRONIC TIMER ( PROBE )

CUSTOMER CONNECT AT SAFETY CONTACTOR T1,2 & 3 FOR 3 Ø    FOR 1 Ø ( 3.1 ONLY ) SEE SHEET 2

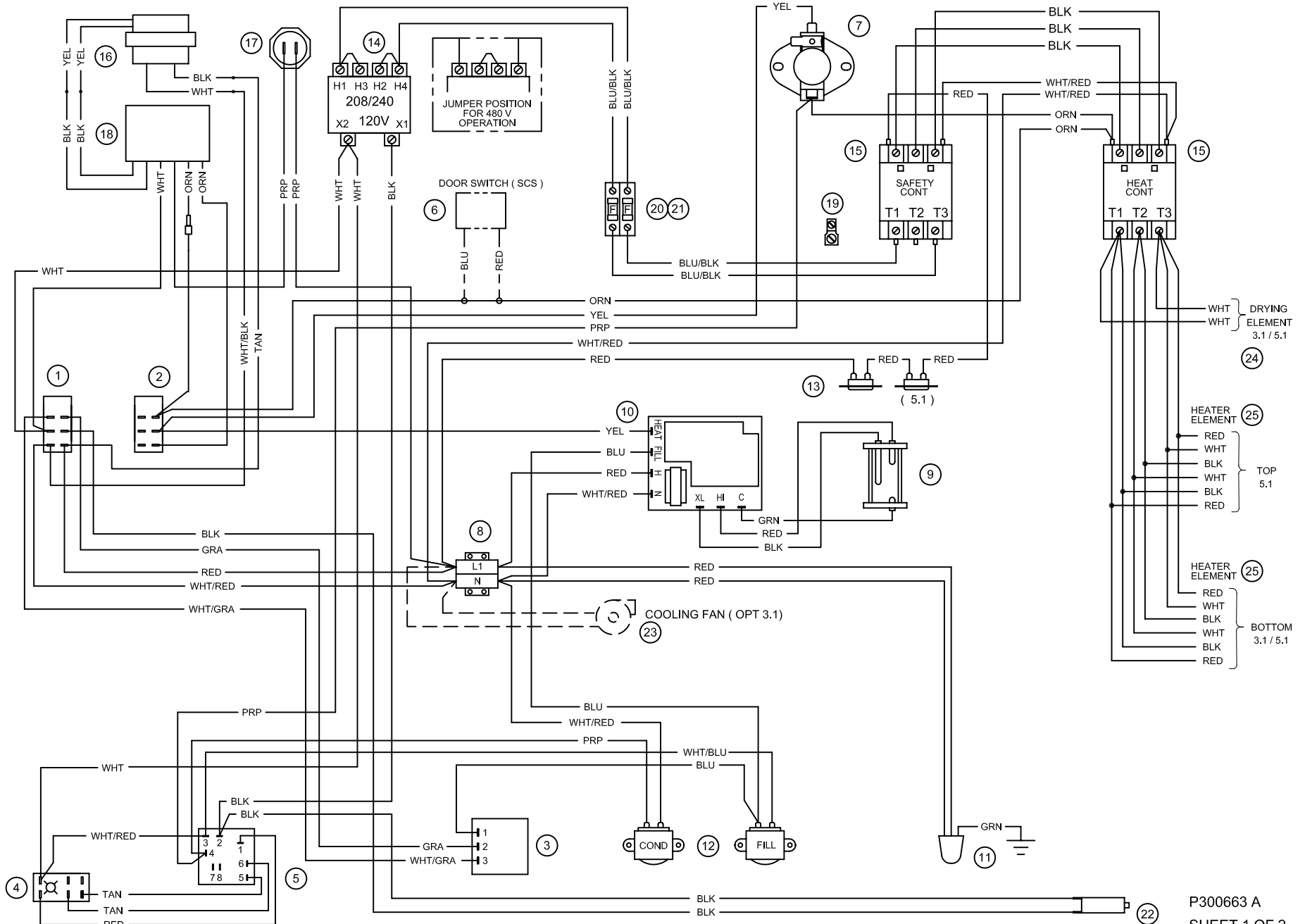

## PARTS LIST

1 19993 - POWER SWITCH	6 108880 - DOOR SW (MAGNETIC)	11 22221 - DRAIN VALVE	16 104390 - TRANSFORMER
2 104224 - TIMED/MANUAL SWITCH	7 105789 - THERMAL SWITCH ( HSB )	12 22218 - WATER SOLENOIDS	17 19972 - COMP THERMAL SW
3 20478 - 3 MIN TIMER	8 44168 - TERMINAL BLOCK	13 103731 - HI LIMIT SWITCHES	18 104389 - ELECTRONIC TIMER
4 19994 - DESCALE INDICATOR RESET SW	9 107239 - PROBE	14 20535 - TRANSFORMER	19 20304 - GROUND LUG
5 106911 - DESCALE TIMER	10 107241 - WATER BOARD	15 03509 - CONTACTORS	20 109374 - FUSE BLOCK
			21 109380 - FUSE, 3.5A
			22 108331 - RESET CIRCUIT BREAKER
			23 107211 - COOLIN FAN (OPT 3.1)

# STEAMCRAFT 3.1 / 5.1 MECHANICAL TIMER (FLOAT)

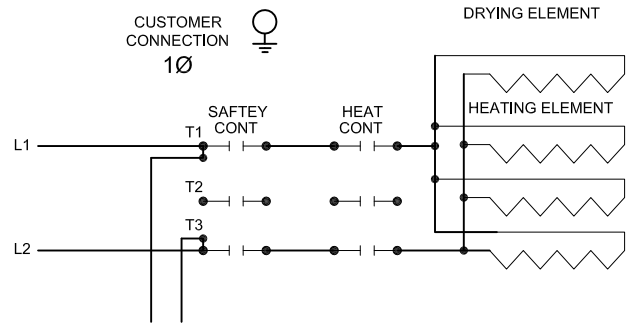
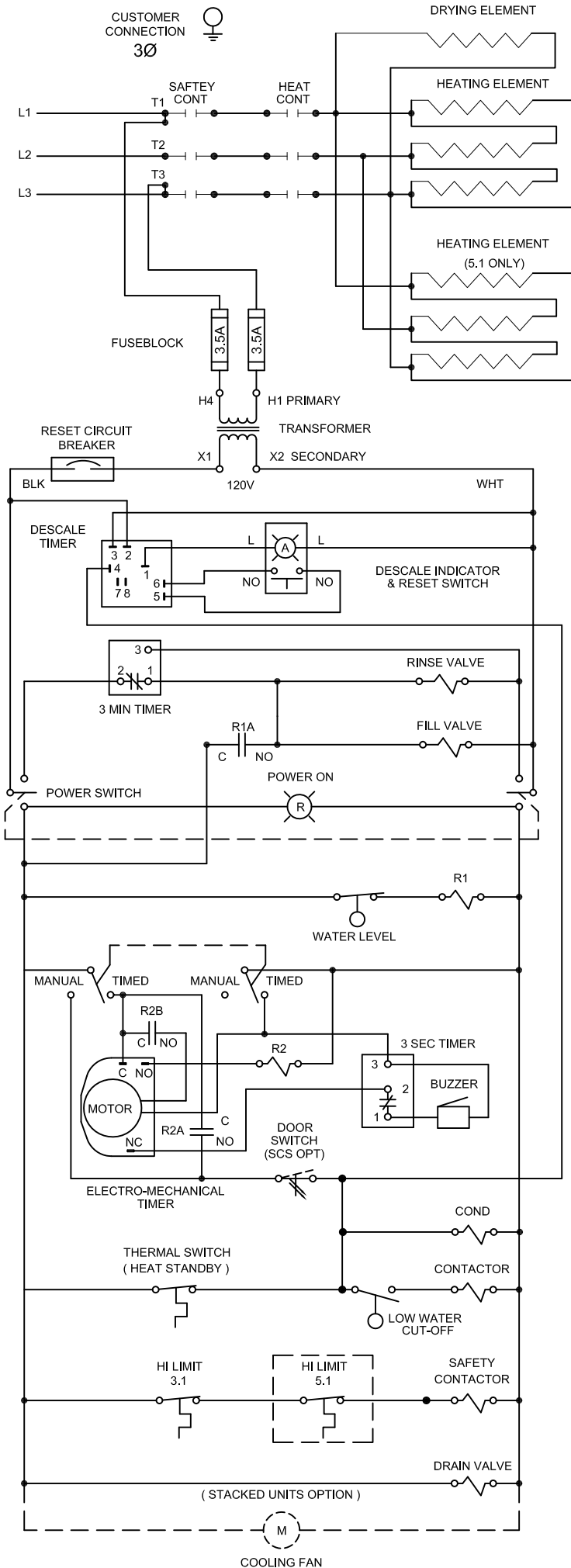

## PARTS LIST

- 1 19993 - POWER SWITCH
- 2 104224 - TIMED/MANUAL SWITCH
- 3 20478 - 3 MIN TIMER
- 4 19994 - DESCALE INDICATOR RESET SW
- 5 106911 - DESCALE TIMER
- 6 108880 - DOOR SW (MAGNETIC)
- 7 105789 - THERMAL SWITCH ( HSB )
- 8 44168 - TERMINAL BLOCK
- 9 103726 - FLOAT
- 10 20304 - GROUND LUG
- 11 22221 - DRAIN VALVE
- 12 22218 - WATER SOLENOIDS
- 13 103731 - HI LIMIT SWITCHES
- 14 20535 - TRANSFORMER
- 15 03509 - CONTACTORS
- 16 105966 - RELAY
- 17 20477 - 3 SEC TIMER
- 18 110198 - MOTORIZED TIMER
- 19 41350 - BUZZER
- 20 109374 - FUSE BLOCK
- 21 109380 - FUSE, 3.5A
- 22 108331 - RESET CIRCUIT BREAKER
- 23 107211 - COOLIN FAN (OPT 3.1)

# STEAMCRAFT 3.1 / 5.1 MECHANICAL TIMER ( FLOAT )

**CUSTOMER CONNECT AT SAFETY CONTACTOR T1,2 & 3 FOR 3 Ø FOR 1 Ø ( 3.1 ONLY ) SEE SHEET 2**

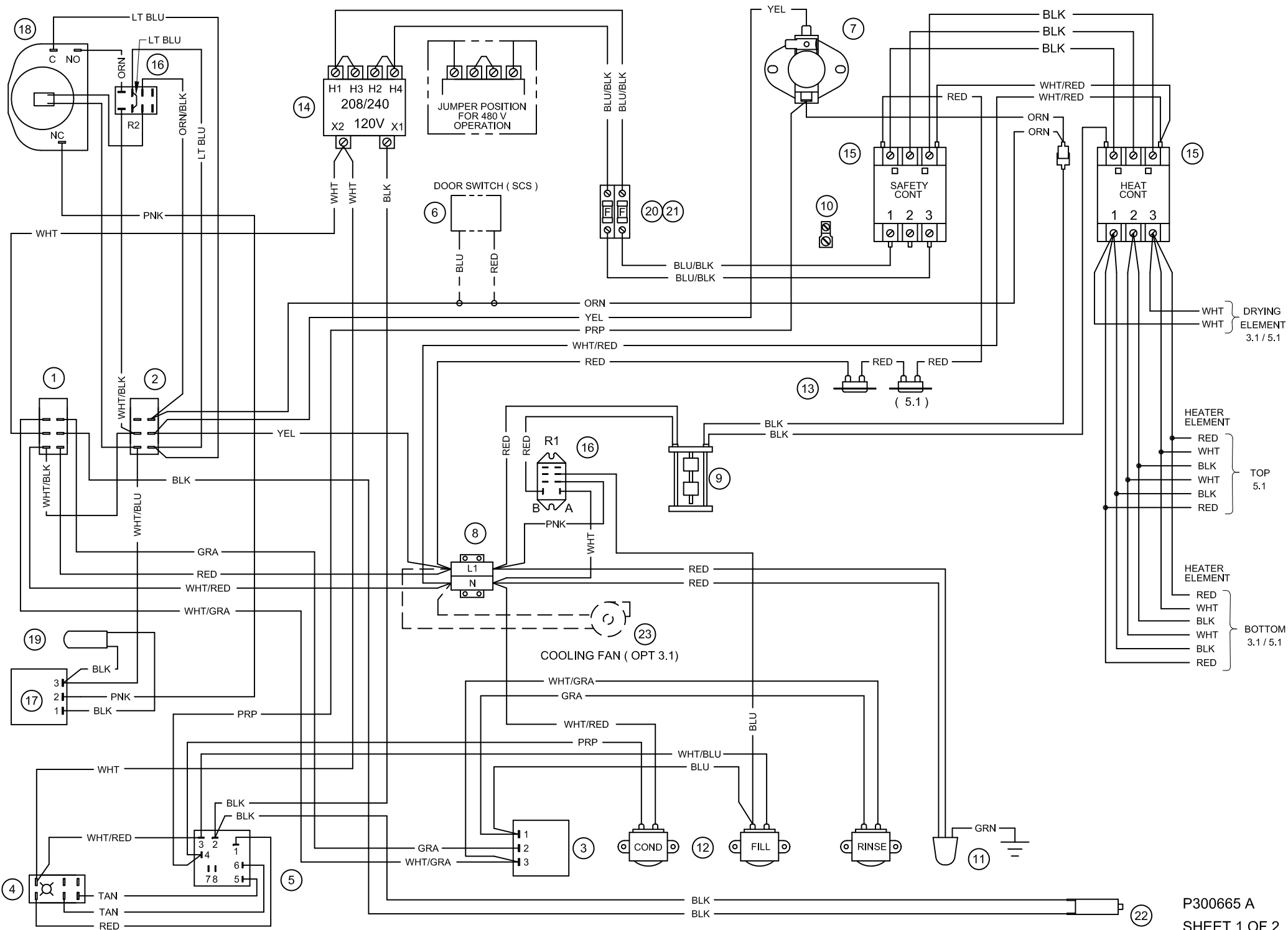



# Cleveland

## Descaling Procedure-SteamCraft Ultra and Gemini Series

### How Much DISSOLVE to Use

Model	Dissolve
Ultra 3	1/2 Gallon
Ultra 5	1 Gallon
Ultra 10 (Elec.)	1 Gallon (ea.)
Ultra 10 (Gas)	1½ Gallon
Gemini 6 & 10	1 Gallon (ea.)

**1. Turn the unit OFF and open the doors:**

This will drain and rinse the generator for about 3 minutes.

**2. Turn the unit power back On:**

The generator will begin to refill with water.

**3. Select Timed with the Timed/Manual switch:**

DO NOT start the timer, since you do not want to heat the water during descaling. Leave the doors open.

**4. Remove descaling port cap and add with the specified amount of DISSOLVE: (See chart above)**

Do this while the unit is refilling. The generators can take-up to 8 minutes to refill.

**5. After refill has stopped, add extra tap water into the descaling port until liquid is seen entering the cooking cabinet.** Note: Ultra 10 gas will have liquid coming out of the drain,

Adding extra water when descaling will raise the descaling solution higher than the normal fill level, allowing the DISSOLVE to work on sensors and surfaces above the water line

Note: Some SteamCraft Ultra models (the electric powered Ultra 10 and Gemini 6 and 10, for example) have two generators and two descaling ports. Both units should be descaled at the same time, using this procedure

**6. Let the descaler soak in generator for approximately one hour:**

**7. After one hour, turn the unit power Off:** This will drain and rinse the generator for about 3 minutes.



**8. After the 3-minute drain cycle completes, turn the unit back ON.** After the filling has stopped, add water until liquid enters the cooking compartment (or drain for the ultra 10 gas), and then turn the unit OFF. This will drain and flush any residue from the water level control assembly. **Replace descaling cap.**

**9. After the 3 minute drain cycle completes, Turn the unit ON and set the Timer for 20 minutes:** Make sure the Time/Manual switch is in the timed setting and the doors are closed.

**10. When the timer times out (after 20 minutes) turn the power Off:**

This will drain and rinse the generator for about 3 minutes.

This ends the descaling procedure. You can now turn the unit back on and resume normal startup and cooking operations.

