

SteamCraft® Ultra 3

COUNTER TYPE DESIGN, PRESSURELESS CONVECTION
STEAMER, ELECTRIC STEAM GENERATOR, 8 KW

Project _____
 Item _____
 Quantity _____
 FCSI Section 11400 _____
 Approved _____
 Date _____

Steamcraft® Generator Style High Speed Convection Steamers

Models

- 21-CET-8



Standard Features

- Cooking Capacity for up to three 12" x 20" x 2 1/2" deep Cafeteria Pans.
- Innovative PowerPak Electric Steam Generator: One Special Stainless Steel Fire Bar Heating Element. Strong 14 Gauge Stainless Steel Construction. Large 3.5 gallon generator reservoir for fast steam cooking production. Fully insulated rear mounted steam generator.
- Easy Access Generator Cleaning Port: Generator Cleaning Port located on the outside, top of the unit. Not necessary to remove hot panels or rack guides to access.
- Instant Steam Stand By Mode: Hold generator at a steaming temperature. Allows unit to start cooking instantly.
- Durable 14 Gauge, Stainless Steel Construction: For compartment door, cavity and steam generator.
- One 60 Minute Electro-Mechanical Timer and Switch for manual operation: Audible signal for cooking time completion.
- Main Power On/Off Switch: With Automatic Water Fill.
- Exclusive Steam Cooking Distribution System: Maintenance Free Exclusive Brass Steam Jets produce a high velocity convection steam without fans. Coved Corner design in cooking compartment distributes heat evenly, and is easy to keep clean. Creased top & bottom enhance drainage. Cold water condenser behind drain maintains a dry steam. Fully insulated cooking compartment for thermal efficiency. Removable Stainless Steel Slide Racks for easy cleaning.
- Automatic Generator Drain: Contains a "Water Jet" Spray Rinse Drain Cleaning Cycle to keep drain clear.
- Exclusive Automatic Remote Probe Type Water Level Control: Separate from the generator for easy access.
- Exclusive "Cool to the Touch" Two-Piece Compartment Door Design: Free floating inner door with reversible gasket provides an air tight seal. Stainless Steel Slam/Latch Door Latch mechanism for reliability.
- Left Hand Door Hinging: Compartment Doors hinged on the left, controls on the right.
- Available in most voltages, single or three phase only.
- Compartment Door Steam Shut Off Switch (SCS)
- 4" Adjustable Legs

Short Form Specifications

Shall be CLEVELAND, SteamCraft® Ultra 3, one compartment, Counter-Type Steamer, Model 21-CET-8, ___volts, 8.5 KW, ___Hz. Heavy duty all Stainless Steel construction. Rear mounted, insulated Steam Generator with Remote Probe Type Water Level Controls and Automatic Steam Generator Blowdown with "Water Jet" Drain Cleaning feature.

Options & Accessories

- Right hand Door Hinging, Controls on the Left (DHR)
- Electronic Timer with Compensating Load Feature (ETC)
- 34" (864mm) High Stainless Steel Economy Stand, for one 21-CET-8 (UniStand34)
- 24" (610mm) High Stainless Steel Stacking Stand (UniStand25), for mounting two stacked 21-CET-8
- POSK Pull-Out Shelf Kit for UniStands (P/N 111724)
- URK Pan Rack Kit UniStands (P/N 111726)
- Equipment Stacking Stand Shelf Type (ES2446)
- Stacking Kit (P/N 107166) includes plumbing for water, a drain and Generator Cleaning Port Connections (STKI) (2 units only)
- Dissolve® Descale Solution, 6 one gallon container w/quart markings (106174)
- Additional Pan Racks for Equipment Stands (PR)
- Cafeteria Pans in depths of 1", 2 1/2" and 4"
- Water Filters

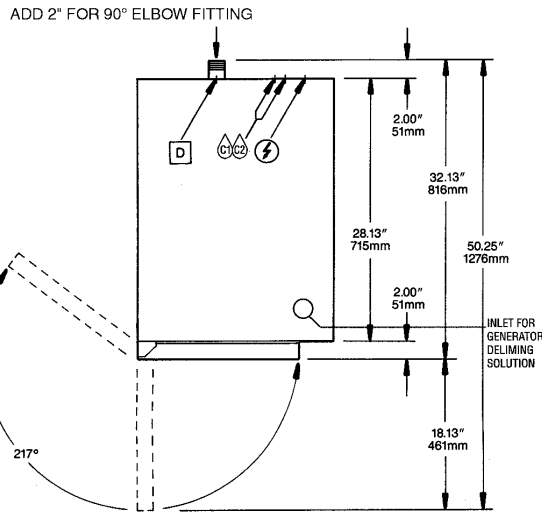
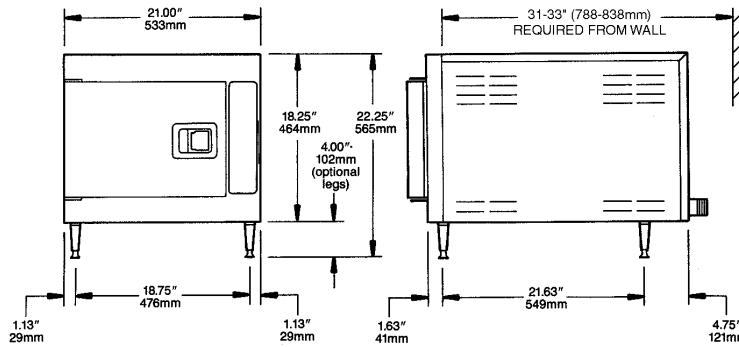
TOP VIEW

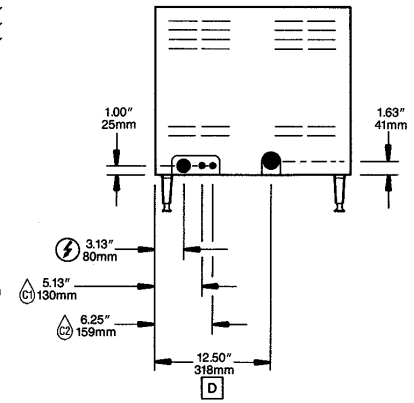
FRONT VIEW
RIGHT SIDE VIEW

 Two 3/4" NH-F (Garden Thread) Connections.
 Use NSF approved hose.

REAR VIEW

COMPARTMENT HAS CAPACITY FOR:

- Three, 12" x 20" x 2 1/2" deep Cafeteria Pans

**NEW WATER QUALITY REQUIREMENTS
(Boilers, Generators)**

| | |
|-----------------------------|----------------------------|
| TDS: | 50-125 ppm |
| Hardness: | 50 - 125 mm (3 - 6 gpg) |
| pH value: | 7.0 - 8.5 |
| CL (Chloride): | max 25 ppm |
| Cl2 (free chlorine): | max 0.1 ppm |
| SiO42 (sulfate): | max 150 ppm |
| Fe (iron): | max 0.1 ppm |
| SiO2 (silica): | max 13 ppm |
| NH2Cl: (mono-chloramine) | max 0.1 ppm |
| Total Alkalinity: | 50 - 100 ppm |
| Water Pressure | 35 - 80 PSI |
| Temperature: | max 104°F |

| ELECTRIC ⚡ | | | | WATER 💧 | | | | DRAINAGE [D] | | CLEARANCE | |
|-------------|-------|------|------|-------------|-------|------|------|--|--|--|--|
| 1 Ph | | | | 3 Ph | | | | Cold water: | | Right - 3", Left - 3", Rear - 3" (12" on control side if adjoining wall or equipment is over 30" high for service access) Contact factory for variances to clearances. | |
| Volts | Watts | Amps | Wire | Volts | Watts | Amps | Wire | 35 psi min., 60 psi max. | | | |
| 208 | 8,300 | 39.9 | 2 | 208 | 8,300 | 23.6 | 3 | Two 3/4" NH-F (Garden Thread) Connections. | | | |
| 220 | 6,974 | 31.7 | 2 | 220 | 6,974 | 18.8 | 3 | Use NSF approved hose. | | | |
| 240 | 8,300 | 34.6 | 2 | 240 | 8,300 | 20.5 | 3 | C1 one for Condenser C2 one for Steam Generator | | | |
| | | | | | | | | 1 1/4" N.P.T. tube | | | |
| | | | | | | | | Do not connect other units to this drain. | | | |
| | | | | | | | | Drain line must be vented. | | | |
| | | | | | | | | No PVC pipe for drain. | | | |

NOTES:

Cleveland Range reserves right of design improvement or modification, as warranted.
 Many regional, state and local codes exist and it is the responsibility of the owner and installer to comply with the codes.
 Cleveland Range equipment is built to comply with applicable standards for manufacturers. Included among those approval agencies are U.L./NSF#4 and CSA (AGA, CGA).

(NOT TO SCALE)