

# SteamChef™ 3

High Speed Convection Steamer, Automatic Water Fill & Drain, Two 32,000 BTU Gas Boiler-Free Counter Type Design

Project \_\_\_\_\_  
 Item \_\_\_\_\_  
 Quantity \_\_\_\_\_  
 FCSI Section 11400 \_\_\_\_\_  
 Approved \_\_\_\_\_  
 Date \_\_\_\_\_

Steamchef™ Boilerless Convection Steamers

## Models

- (2) 22CGT33.1



## Standard Features

- Cooking capacity for up to three 12" x 20" x 2.5" deep steam table pans (1/1 G/N, 65 mm) per compartment.
- High-speed gas convection steamer with open style 1.0 gallon water reservoir located at the bottom of the cooking compartment for easy access and maintenance.
- Fan forced convection steam with patented KleanShield™ cooking compartment design. KleanShield™ collects and removes condensate waste from the cooking compartment. This keeps the compartment clean, safe from impurities and easy to maintain. Reduces foaming and avoids contamination of the reservoir water.
- Automatic water level controls, fills when main power switch is turned ON, Low Water and High Water probes inside cooking compartment maintains water levels during cooking, eliminating the need to manually refill and monitor water level during cooking. Large overflow port in rear wall. 193° preheat and standby temperature. High Temperature Automatic Safety Shut-off.
- Steam and Fan Shut Off Control when compartment door is opened.
- 32,000 BTU (per compartment) high efficiency atmospheric gas boilerless style heating system.
- Front access works in a drawer style burners for easy servicing.
- Includes a 60-Minute Electro-Mechanical Timer, LED Indicator Lights for Power On and Reset. Timed and Manual Bypass Switch for constant steaming.
- Exclusive SteamChef™ Automatic Drain Control. Compartment drains when main power is turned OFF via 1/2" ball valve with micro switch circuitry. Simple 1.5" NPT drain connection required with water saving cold water condenser and 3 minute rinse feature.
- Left Hand Door Hinging: Compartment Doors hinged on the left, controls on the right.
- Exclusive, durable 14 gauge stainless steel compartment door and latch withstands abuse and heavy wear. Two piece compartment door with free floating inner door is self adjustable and prevents leaks. Reversible door gasket doubles the life of the gasket.
- Heavy-duty 4" (102mm) Skid Resistant Adjustable Legs with Flanged Feet.
- UL - Gas, UL - Sanitation (NSF Standards).
- Stacking combination requires field installation of the steamers, stand and flue. This combination includes the following items:
  - ES26304433G Stacking Stand (PN 113131G)
  - Gas Flue Exhaust Kit
  - Common Drain and Water Connection Manifold.

## Short Form Specifications

Shall be a Cleveland SteamChef™ 3, model (2) 22CGT33.1, two stacked single compartment 32,000 BTU high efficiency atmospheric gas boilerless style heating systems. Front access "works in a drawer" style burners for easy servicing. Standard 60-minute electro-mechanical timers. Capacity for three 2.5" (1/1 G/N, 65 mm) full size steam table pans per compartment. Includes 1/2" ball valve style automatic drains. Automatic water level controls. Heavy-duty 14 gauge stainless steel cooking compartment doors and latches. KleanShield™ clean cavity protection. 4" Adjustable Legs. Requires field installation. Includes Stacking Stand, Gas Flue Exhaust Kit and Common Drain and Water Connection Manifold.



## Options & Accessories

- 5 Foot (1524mm) FDA Approved National Hose Thread style water connection kit (garden hose thread), 2 required (NHT60)
- Single Point Water Connection (SPW)
- Electronic Timer

Each compartment has capacity for:

- Three, 12" x 20" x 2 1/2" deep Cafeteria Pans  
or
- Six, 12" x 20" x 1" deep Cafeteria Pans.  
or
- Two, 12" x 20" x 4" deep Cafeteria Pans

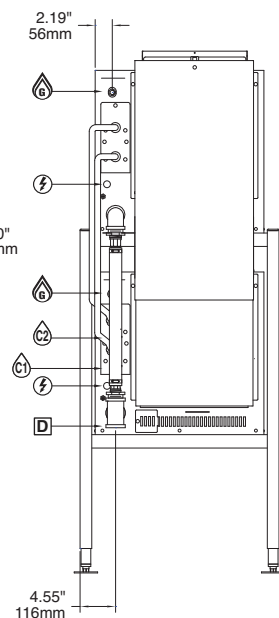
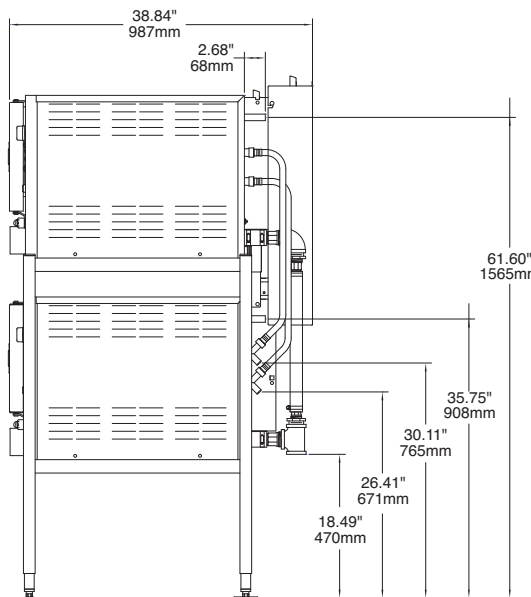
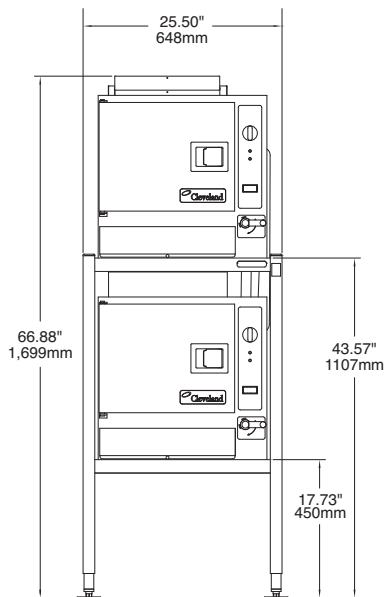
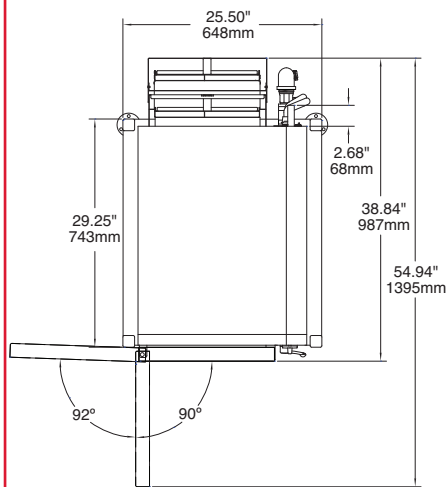

### OPERATING CLEARANCES

3" Left, 3" Right and 3" Rear.

### SERVICE CLEARANCES

12" on control side. Contact factory for variances to clearances.

### CONTROLS (per compartment)

60-minute electro mechanical timer with load compensating feature.  
Two function control switch for Timed Cooking and Continuous Steaming.

### APPROVALS

UL - Gas, UL - Sanitation (NSF Standards)

#### GAS (one connection per unit)

1/2" Dia. IPS

32,000 BTU's

**SUPPLY PRESSURE:** NATURAL - 4.00' W.C. minimum, 14.00' W.C. maximum  
PROPANE - 11.00' W.C. minimum, 14.00' W.C. maximum

Manufacturer must be notified if unit will be used above 2,000 ft. altitude.

#### ELECTRICAL (one connection per unit)

120V, 1 Phase, 4 Amps.

#### COLD WATER

C-1: Feed water for reservoir, 35 Psi Minimum, 60 Psi Maximum.

C-2: Drain condenser water, 35 Psi Minimum, 60 Psi Maximum.

Two 3/4" NH-F (Garden Thread) connections. Use NSF approved hose.

#### DRAIN CONNECTION

1.5" NPT-M

Do not connect other units to this drain.

Drain line must be vented.

Do not connect the appliance's drain connection to any drain material that cannot sustain 140°.

#### NOTES:

Cleveland Range reserves right of design improvement or modification, as warranted.  
Many regional, state and local codes exist and it is the responsibility of the owner and installer to comply with the codes.  
Cleveland Range equipment is built to comply with applicable standards for manufacturers. Included among those approval agencies are U.L./NSF#4 and CSA (AGA, CGA).

(NOT TO SCALE)