



Model: **BWS1500/50**

Part #: 164-15545

Snapshot

The OptiPure® BWS1500/50 Water Treatment System utilizes reverse osmosis (RO) to remove >97% of the total dissolved solids (TDS) from water. Then a balance of minerals is dissolved into the RO water, followed by a precision blend valve for further TDS adjustment, to provide desirable “Optimized” water TDS. The system is pump-driven and will produce up to 1500 gallons per day of optimal quality water for applications where TDS reduction or the removal of the majority of hardness minerals is required. This complete system includes integrated pre-filtration with particulate and chlorine reduction, reverse osmosis, blend valve and mineral addition, in a space saving, wall-mount design. Adjustable Reject Flow Control allows precise adjustment of Product/Reject Ratio. A built-in full system bypass valve and sample port assures no service interruption and simplifies routine maintenance. Also included is a 50 gallon atmospheric storage tank with a top-mounted variable-flow repressurization system and a sub-micron air breather. Hose, tubing and fittings required for installation are included.

System Benefits

- Virtually eliminates scale & corrosion problems related to high TDS & water hardness and reduces the potential for corrosion related to water chemistry.
- Precision Blending Valve allows the user to accurately and precisely blend filtered water with mineral-addition water to a desired (Optimized) TDS level.
- Microprocessor Controller provides system status and pump time-delay on start-up for pump protection.
- Rotary Vane Pressure Pump assures consistent production.
- Adjustable Reject Flow Control minimizes water use due to seasonal fluctuations in water temperature.
- Dual-read digital TDS meter provides monitoring of membrane performance and optimized water quality.
- Sample Port enables quick and simple system checks and adjustments.
- Built-in pressure gauge allows visual monitoring of operating pressure.
- Integrated system bypass valve eliminates down-time or service interruptions.
- All consumables are easy-to-change Qwik-Twist cartridges.

ITEM #: _____ QTY: _____

JOB NAME/NUMBER _____



Application

Any foodservice equipment where it is desirable to remove existing TDS (total dissolved solids) and provide a consistent balance of buffered TDS.

Installation Tips

- Feed-water connection to system should be COLD only.
- Do not exceed system specifications for temperature and pressure.
- Provide a dedicated 1/2" water line to the unit for consistent flow and pressure to the system.
- Allow 3" clearance below system for filter cartridge removal and replacement.
- Connect filtered water line to steam production connections only. Do not use for condenser water.
- Detailed installation, operation & maintenance manual included with each system.
- Mount the unit where it can be easily serviced.

Water Processor Assembly - 120V

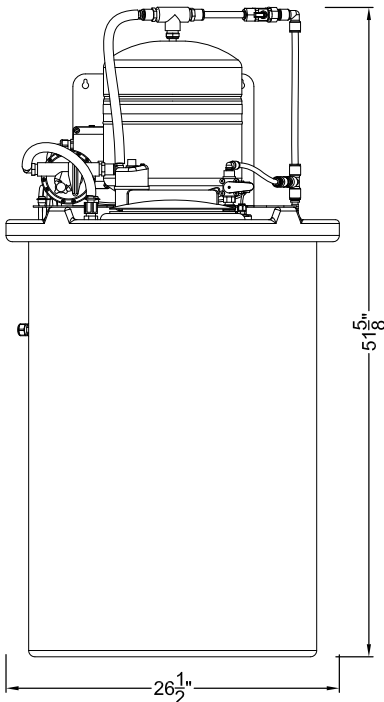
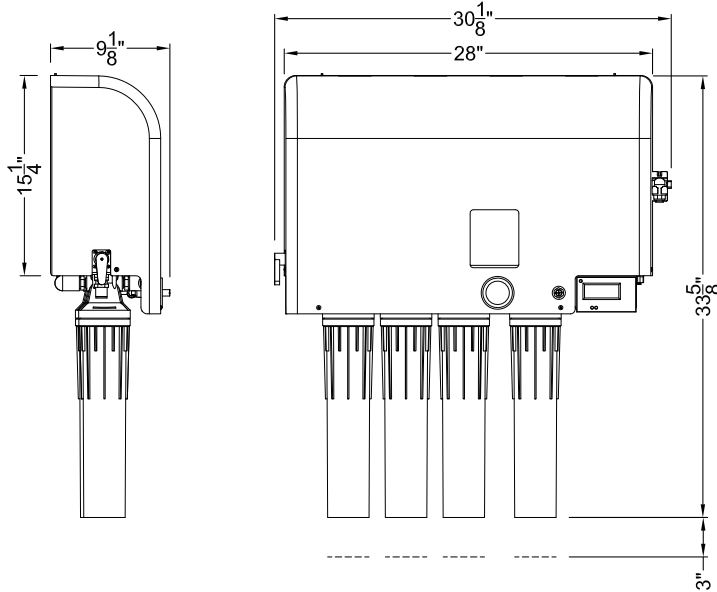

Re-pressurization/Storage Tank Assembly

Note: Re-pressurization Pump/ Buffer Tank Stand Assembly can be removed from top of tank and placed on floor or shelf in close proximity of the tank. Use Remote Kit PN: 164-89116.

Feed-Water Chemistry

Feed TDS	Up to 1200 ppm
Feed pH	6-10
Hardness	12 grains or less
Free Chlorine	<2 mg/l
Iron	0.1 mg/l max
Turbidity	0.05 NTU
Manganese	0.05 mg/l max
Hydrogen Sulfide	0.0 mg/l

For water outside of these parameters call OptiPure technical service.

Specifications

System		
Dimensions	RO Processor	34" h x 31" w x 8.4" d
	Repressurization/Storage Tank	39.4" h x 26.5" dia.
Connection - Feedwater	1/2" Push Fit Tubing	
Feed-Water Pressure Range	30 - 90 psi at 2.5 gpm (2.1 - 6.2 bar)	
Inlet Water Temperature Range	40 - 100°F (4 - 38°C)	
Shipping Weight		
Drain Flow Requirement	5 GPM Minimum Flow	
Power	- Water Processor	120V 60Hz 6A
	- Re-pressurization Pump	120V 60Hz 8A
Performance		
Typical TDS Rejection	>97%	
Product Water Production (at 77°F, 60psi)	1500 gals/day 62 gals/hr 1.0 gpm	
<i>Production rate is strictly dependent on feed water temperature and pressure.</i>		

Replacement Media

Description	Part Number	Qty
CTO-Q Pre-Filters	300-05830	3
AMS-QT Membrane	204-44021	1
MA-Q15 Post-Treatment	300-05855	1

It is recommended that pre-filters and mineral addition cartridge be changed every 3-4 months, when capacity is reached or when effluent pressure or flow becomes inadequate. Membrane life varies from 24-60+ months, depending on feed water conditions and pre-filter maintenance.

Options

Description	Part Number
Approved Air Gap Kit for Drain Line	164-89905
FX-11CR Chloramine Reduction System	160-50011

This product is for commercial use only and must be installed and maintained according to manufacturer's guidelines.

Do not use on water that is microbiologically unsafe or of unknown quality without adequate disinfection before or after the system.

Warranty

Systems have a 1 year warranty against defects in material and workmanship. Warranty does not include filters or membranes. For complete warranty information, contact OptiPure customer service.

Dealer/Distributor Info:

OptiPure, a division of AQUION
 2605 Technology Dr., Bldg 300 Plano, TX 75074
 p: 972.881.9797; f: 972.422.6262
 e: info@optipure.net www.optipurewater.com