

Snapshot

The **QTSX-2PG** is a dual-cartridge water treatment system with two 15" Quick-Twist cartridges, that reduces sediment down to 0.5 microns, and reduces chlorine, taste & odor at a flow rate of 1.0 gpm for minimum of 22,500 gallons. The system includes a ScaleX2 Cartridge that incorporates a chemical-free scale inhibition technology that utilizes Template-Induced Crystallization to effectively inhibit the formation of calcium-carbonate scale. A pressure gauge kit is included.

System Benefits

- Reduces maintenance frequency and cost, and extends equipment life.
- ScaleX2 Protects boilers, steam generators, and coffee equipment against the formation and accumulation of scale.
- Gradient-density sediment filtration protects against dirt, rust and other debris down to 0.5 microns.
- High-capacity activated-carbon filtration makes water taste great and protects equipment against corrosive chlorine.
- Sturdy, powder-coated mounting bracket and full-flow inlet shut-off valve simplify installation.
- Inlet shut-off valve makes filter replacement quick and simple.
- Utilizes Quick-Twist cartridges that make changing filters quick, easy and sanitary.
- Pressure Gauge Kit included.



Application

COFFEE & TEA - Applications up to 1.0 gpm where water hardness is a problem.

BOILER-BASED STEAM GENERATORS - Applications up to 1.0 gpm where water hardness and chlorine are a problem.

Installation Tips

- Feed-water connection to system should be COLD only.
- Do not exceed system specifications for temperature and pressure.
- Allow 3" clearance below system for filter cartridge removal and replacement.
- Detailed installation, operation & maintenance manual included with each system.
- No activation procedure or flushing required for system to perform as specified.

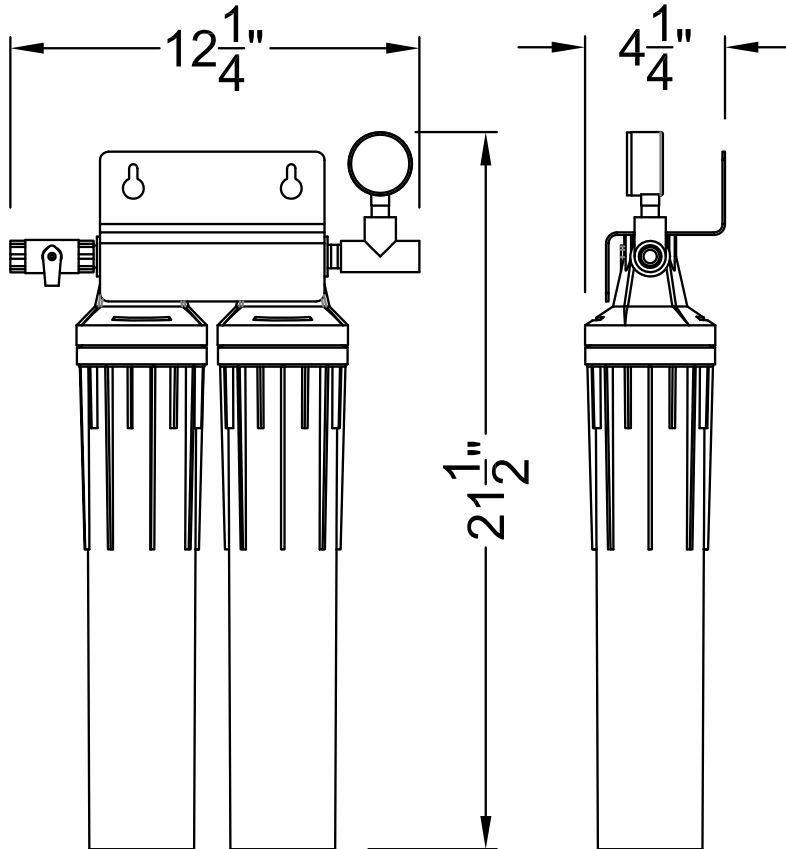

► Specifications

System	
Dimensions (Height x Width x Depth, inches)	21.5" x 12.3" x 4.3"
Connection - Inlet & Outlet	3/8" NFPT
Operating Pressure Range	10-125 psi (0.7 -8.6 bar)
Inlet Water Temperature Range	35 - 100°F (2 - 38°C)
Shipping Weight	12 lbs.
Performance	
Chlorine, Taste and Odor Reduction Capacity	22,500 gals. (85,162 liters)
Service Flow Rate	1.0 gpm (3.8 lpm)
Sediment Reduction	.5 micron (nominal)
Scale Inhibitor	ScaleX2®

Pressure Gauge Kit Included- Part #: 160-52904
Optional Flush Valve Kit - Part #: 160-52912

► Water Chemistry & Limits

Parameter	Max. Allowable
pH	6.5-8.5
Iron, ferrous	0.3 mg/L
Manganese	0.05 mg/L
Copper	0.3 mg/L

Do not use on water that is microbiologically unsafe or of unknown quality without adequate disinfection before or after the system.

This product is for commercial use only and must be installed and maintained according to manufacturers guidelines.

► Replacement Cartridge(s)

Model	Part Number	Qty
CTO-Q	300-05830	1
SCLX2-Q	300-05860	1

It is recommended that the CTO-Q be changed every six months, when capacity is reached or when effluent pressure or flow becomes inadequate. In most applications the ScaleX2® cartridge will perform for up to one year between filter changes.

► Warranty

Systems have a 3-year warranty against defects in material and workmanship. For complete warranty information, contact OptiPure customer service.

OptiPure, a division of AQUION

2605 Technology Dr., Bldg 300 Plano, TX 75074
p: 972.881.9797; f: 972.422.6262
e: info@optipure.net www.optipurewater.com

Dealer/Distributor Info: