

NOTE:

1. ITEM 4 P/N 58109 IS NOT INCLUDED IN THE PRODUCTION LINKAGE ASSEMBLY P/N 103909,  
 IT IS SUPPLIED AS PART OF THE INLET VALVE P/N 22212.  
 THE SERVICE LINKAGE ASSEMBLY P/N 1039093 INCLUDES ITEM 4 P/N 58109.

LET.	REVISIONS	DATE	BY
A	PICTORIAL REVISION TO ITEM 4, PER EO #C-5381	6-16-99	DS
B	1) ADDED NOTE 1, 2) ADDED SERVICE ASSY P/N 1039093	04-27-09	DS
-	PER ECR-08-120	-	-

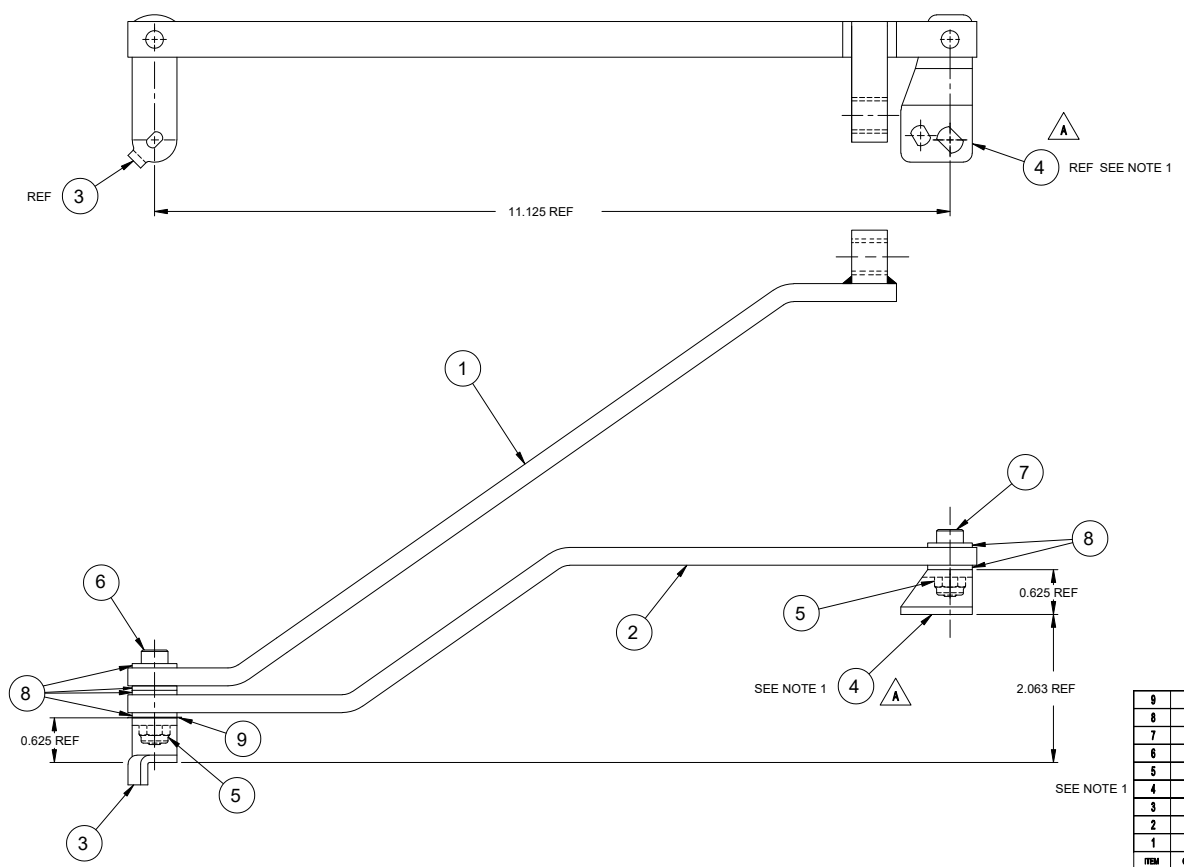

9	1	23143	WASHER, FLAT, 0.250 ID, .910 THICKNESS
8	6	23116	WASHER, FLAT, 0.250 I.D. X .825 O.D. X .065 THK, SST
7	1	18157	SCREW, SHOULDER, 1/4 DIA. X 3/8 L.G.
6	1	18158	SCREW, SHOULDER, 1/4 DIA. X 3/4 L.G.
5	2	14892	NUT, HEX, LOCK, 10-24
4	1	58109	HANDLE, STEAM INLET VALVE
3	1	58108	HANDLE, 1" BUTTERFLY VALVE
2	1	88216	ROD, INLET LINKAGE
1	1	1039091	LINKAGE ASSY, EXHAUST

CLEVELAND RANGE, LLC			
1333 East 179th St., Cleveland, Ohio 44110-2574			
THIS DESIGN DESCRIBES A PROPRIETARY ITEM AND IS THE PROPERTY OF CLEVELAND RANGE. THIS DESIGN IS NOT TO BE COPIED OR REPRODUCED WITHOUT THE APPROVAL OF CLEVELAND RANGE.			
TOLERANCES UNLESS OTHERWISE NOTED	DO NOT SCALE PRINTED DRAWING	DRAWN BY	DATE
DECIMAL ±.030			
ANGULAR ±1°	SIZE C	DRAWING NO. 103909-1039093	TITLE LINKAGE ASSEMBLY, AUTOMANUAL MODEL J STEAMER
		SHEET 1 OF 1	REV B