

Cleveland

LEG TYPE, GAS-FIRED KETTLES

"SPLASH PROOF SERIES" 40, 60, OR 80 GALLONS (150, 225, OR 300 LITERS)

SHORT SERIES™ GAS-FIRED KETTLE

38" RIM HEIGHT, "SPLASH PROOF SERIES" 40 GALLONS (150 LITERS)

Project _____
 Item _____
 Quantity _____
 FCSI Section 11400 _____
 Approved _____
 Date _____

Models • KGL-40-T • KGL-80-T • KGL-60-T



Shown with standard controls, optional Spring Assisted Cover and 2" Tangent Draw-Off Valve



Optional easyDial Controls

Standard Features

- High efficiency Power Burner Heating System (62% to 65% efficiency)
- Fast Heat-up and Recovery Time, 140M BTU's on 40 gallon models, 190M BTU's on 60 gallon and larger
- Insulated Heat Exchanger
- Automatic Hot Surface Ignition System
- Steam Jacket permanently filled with treated, distilled water. Venting and/or refilling not required.
- Accurate, constant solid state temperature controls - less than $\pm 1^\circ\text{C}$ variance (ideal for simmering). Operating temperature range from 145° - 260°F (63°C - 127°C)

Standard Control Panel includes:

- LED indicator for heat cycle • LED indicator for low water
- Power ON/OFF Dial with 1-10 Temperature Dial Setting

easyDial Control Panel (optional) includes:

- Adjustable Temperature Control (C&F) • 99 Minute Adjustable Timer Setting • 3 Cooking Models, Cook/Simmer, Cook/On, Cook Off • 6-Built In Self Diagnostics & Display Readout • Core Temperature Probe (Optional)
- Front mounted combination Pressure/Vacuum Gauge
- Type 316 Stainless Steel with #4 finish on kettle
- Tilt Mechanism of roller bearings and case hardened self-locking worm and segment gear
- Support Legs with level adjustable feet, flanged for floor bolting
- Large pouring lip for easier, faster, pouring. Heavy-duty Rolled Rim design provides strong reinforcement, prevents damages from abuse
- 50 psi Steam Jacket Rating and Safety Valve
- Standard voltage is 115 volts, 60 Hz, single-phase, supplied with cord and plug
- Standard for natural gas operation
- Typical approvals include AGA, CSA, CE, NSF and ASME

Short Form Specifications

Shall be CLEVELAND, Gas-Fired Tilting Kettle, Model KGL- ____ T; ____ gallons, 2/3 Steam Jacketed, Power Burner Heating System, Insulated Heat Exchanger, 50 psi Steam Jacket Rating. Infinite Variable Temperature Control, L.E.D. indicators for Heat Cycle and Low Water Warning, Automatic Ignition System. 316 Stainless Steel Interior.

Model • KGL-40-TSH



Shown with optional Spring Assisted Cover and 2" Tangent Draw-Off Valve

Options & Accessories

- easyDial option • Core Temperature Probe
- Pan Carrier (PCK) • Flow Diverter (FD) • Food Strainer (FS)
- Kettle Markings (KM) • Drain Strainers (DS-)
- Cooking Baskets and Tri-Basket Supports (BS and TBS)
- Faucet Mounting Bracket (FBKT)
- 2" or 3" diameter Tangent Draw-Off Valve (TD2 or TD3), Will raise height of kettle by 1" (25.4mm)
- Drain Strainers (DS-)
- 3" diameter Butterfly Valve (BV3)
- Spring-assisted, hinged, rotatable, domed Stainless Steel Cover (CHS-)
- Hot and Cold Water Faucet with Swing Spout (DPK)
- Kettle Accessory Kit (KAK) includes:
 - Clean-up Brush (CB) • 36" Kettle Paddle (KP) • 24 oz. Ladle (KL)
 - 36" Kettle Whip (KW) • 36" Kettle Brush • Draw-Off Brush (DB)
- Automatic Water Meter (GMF or LMF)
- Measuring Strip (MS)
- Option for Propane Gas operation
- Correctional Package
- Heat Deflector Shield (HS001)

Short Form Specifications

Shall be Cleveland Gas-Fired Tilting Kettle, Model KGL-40-TSH, 37 1/2" rim height, Fully Steam Jacketed, 50 psi Steam Jacket Rating, 140,000 BTU Double Pass Steam Generator, Power Burner System, Splash Proof Solid State Temperature Controls, Automatic Hot-Surface Ignition System. 316 Stainless Steel Interior.

KE004046-73

Cleveland

MODEL	VALVE	A	B	C	D	E	F	G	H	J	K	L	M	N	O	P	Q	R	S I.D.	T	
KGL-40-T	NONE		N/A	N/A	N/A			71	40 1/2	N/A	23 1/4			5 1/2	25					N/A	
	TD-2		42 1/2	38	35			76	45 5/8	15 1/2				4 1/2	25 3/4					N/A	
	TD-3	45 3/4	47 1/2	39 3/8	35 3/4	9	42 1/4				28 3/8	19	35 3/4	3 5/8	26 1/2			33	63	26	
	BV-3							71	40 1/2	12 1/2	23 1/4			5 1/2	25				19	6 1/2	
KGL-60-T	NONE		N/A	N/A	N/A			75	43 3/4	N/A	24 1/2			6	27 1/2					N/A	
	TD-2		46	41 1/2	37			80	48 1/8	18	28 7/8	22	39 3/8	5	28 1/2				37	68	29 1/2
	TD-3	49 3/8	51	43	38	11 3/4	47 1/4			12 3/4	24 1/2			6	27 1/2				22	7 3/4	
	BV-3							75	43 3/4	14	24 1/2			6	27 1/2				22	7 3/4	
KGL-80-T	NONE		N/A	N/A	N/A			78	44 3/4	N/A	25			6 1/2	30					N/A	
	TD-2		49	44 1/2	39			82	48 7/8	16 1/2	29 1/8	25	43	6	30 3/8				40	72	33
	TD-3	53	54 3/8	46 1/4	40 1/4	14 3/4	51			11 3/4	25			6 1/2	30				24	9	
	BV-3							78	44 3/4	14	26 1/2			6	27 1/2				24	9	
KGL-40-TSH	NONE		N/A	N/A	N/A			67 7/8	36 5/8	N/A	24 1/2			6	27 1/2					N/A	
	TD-2		46	41 1/2	37			72 7/8	41	18	28 7/8	22	39 3/8	5	28 1/2				37	68	29 1/2
	TD-3	49 3/8	51	43	38	11 3/4	47 1/4			12 3/4	24 1/2			6	27 1/2				22	7 3/4	
	BV-3							67 7/8	36 5/8	14	24 1/2			6	27 1/2				22	7 3/4	

LEGEND: TD-2 = 2" TANGENT DRAWOFF VALVE, TD-3 = 3" TANGENT DRAWOFF VALVE, BV-3 = 3" BUTTERFLY VALVE, FPVA-3 = 3" AIR VALVE

ALL DIMENSIONS IN INCHES.

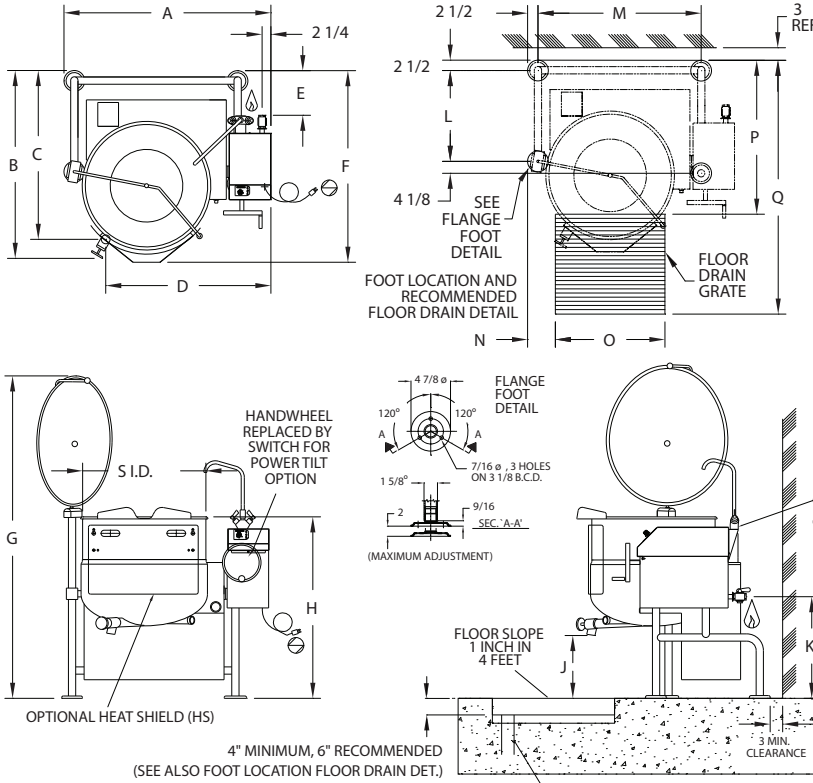

UNIT SHOWN WITH OPTIONAL 2" TANGENT DRAWOFF VALVE, SPRING ASSIST COVER, HOT AND COLD WATER FAUCET

SPECIFICATIONS:

MODEL	ELECTRICAL SUPPLY:				GAS SUPPLY: (PIPING 3/4 NPT)				APPROVALS				CLEARANCE:	SHIPPING WEIGHT	
	VOLTS	PHASE	AMPS	FREQ	TYPE	BTU RATING	WATER COLUMN	BTU PER CU. FT.	SUPPLY PRESSURE	AGA	CGA	CE MARK			NSF
KGL-40-T	120	1	10	60	NAT	140,000	3.5	1000	4" TO 14" W.C.	✓	✓	✓	✓	RIGHT: 0 inches	KGL-40-T 527 LBS.
	120	1	10	60	LP	140,000	3.5	2500	4" TO 14" W.C.	✓	✓	✓	✓	LEFT: 0 inches	
	220	1	5	50	NAT	140,000	3.5	1000	4" TO 14" W.C.	✓	✓	✓	✓	REAR: 3 inches	
	220	1	5	50	LP	140,000	3.5	2500	4" TO 14" W.C.	✓	✓	✓	✓		
KGL-60-T	120	1	10	60	NAT	190,000	3.5	1000	4" TO 14" W.C.	✓	✓	✓	✓	ALLOW 12" SPACE MINIMUM ON RIGHT SIDE FOR SERVICE	KGL-60-T 600 LBS.
KGL-80-T	120	1	10	60	LP	190,000	3.5	2500	4" TO 14" W.C.	✓	✓	✓	✓		
KGL-40-TSH	220	1	5	50	NAT	190,000	3.5	1000	4" TO 14" W.C.	✓	✓	✓	✓		
	220	1	5	50	LP	190,000	3.5	2500	4" TO 14" W.C.	✓	✓	✓	✓		

NOTES:

1. MANUFACTURER MUST BE NOTIFIED IF UNIT WILL BE OPERATING ABOVE 2,000 FOOT ALTITUDE.
2. CONSULT FACTORY FOR MANUFACTURED GAS.
3. ALL VERTICAL DIMENSIONS SHOWN ARE MINIMUM. FEET ARE ADJUSTABLE TO 1 INCH MAXIMUM.
4. UNIT COMES WITH 6' POWER CORD.

NOTES:

Cleveland Range reserves right of design improvement or modification, as warranted. Many regional, state and local codes exist and it is the responsibility of the owner and installer to comply with the codes. Cleveland Range equipment is built to comply with applicable standards for manufacturers. Included among those approval agencies are U.L./NSF4 and CSA (AGA, CGA).

CAPACITIES: (in 8 oz. servings, other sizes may be calculated)
 40 Gallon / 150 liters . . . 640 servings
 60 Gallon / 225 liters . . . 960 servings
 80 Gallon / 300 liters . . . 1280 servings

T.D. VALVE OPTIONS

VALVE	CLEARANCE REDUCTION
TD-2N	1 3/4
TD-3N	2 1/2
TD-2A	1/2
TD-3A	1 3/4

FOR VALVES WITH ACME THREADS (TD-2A, TD-3A) AND NPT THREADS (TD-2N, TD-3N) REDUCE CLEARANCE BETWEEN VALVE OPENING AND FLOOR BY AMOUNT SHOWN.

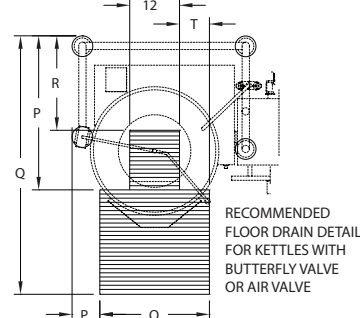
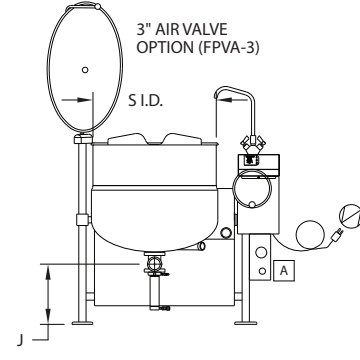
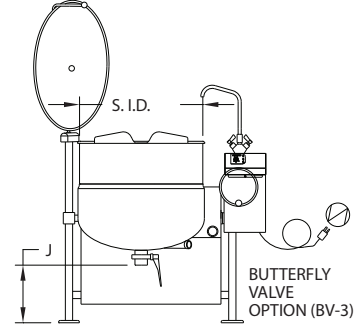

WARNING: TO PREVENT INJURY KETTLE MUST BE BOLTED TO FLOOR.

- A AIR: PIPING: 1/2 NPT PRESSURE: 90-100 PSI FLOW RATE: 5 CU. FT PER MIN.
- C COLD WATER: H HOT WATER: PIPING: 1/2" NPT (DOUBLE) PIPING: 3/8" COPPER TUBE (SINGLE)

(NOT TO SCALE)

Gas Kettles

760 Beta Drive, Unit D
 Mayfield Village, Ohio 44143

Tel 1.216.481.4900
 Fax 1.216.481.3782
 Email steam@clevelandrange.com

www.clevelandrange.com
 04 / 2026

Timeless Quality, Trusted For Life®