



Visit [www.clevelandrange.com](http://www.clevelandrange.com) to locate a service or sales representative in your area.



# Electric Floor Model Kettles

## Installation, Operation, Maintenance, Parts & Service

This manual is updated as new information and models are released. Visit our website for the latest manual.

### MODELS:

- KEL-25    KEL-25-T    KEL-40-SH
- KEL-30    KEL-40-T    KEL-40-TSH
- KEL-40    KEL-60-T    KEL-60-SH
- KEL-60    KEL-80-T    KEL-60-TSH
- KEL-80    KEL-100-T
- KEL-100

*For your future reference.*

Model # \_\_\_\_\_

Serial # \_\_\_\_\_



Model # & Serial #.



**Read the manual thoroughly.**  
**Improper installation, operation or maintenance can cause property damage, injury or death.**

### TABLE OF CONTENTS

- Statement of Responsibilities ..... 1
- For your safety ..... 2
- Installation ..... 4
- Operating Instructions ..... 6
- Cleaning Instructions ..... 7
- Preventative Maintenance ..... 8
- Trouble Shooting & Maintenance ..... 9
- Service Parts ..... 20



# **STATEMENT OF RESPONSIBILITIES / DÉCLARATION DES RESPONSABILITÉS / DECLARACIÓN DE RESPONSABILIDADES**

This document is for use by experienced and trained Qualified Cleveland Range, LLC Authorized Service Representatives who are familiar with both the safety procedures, and equipment they service. Cleveland Range, LLC assumes no liability for any death, injury, equipment damage, or property damage resulting from use of, improper use of, or failure to use the information contained in this document. Cleveland Range, LLC has made every effort to provide accurate information in this document, but cannot guarantee that this document does not contain unintentional errors and omissions.

The information in this document may be subject to technical and technological changes, revisions, or updates. Cleveland Range, LLC assumes no liability or responsibility regarding errata, changes, revisions, or updates.

Qualified Cleveland Range, LLC Authorized Service Representatives are obligated to follow industry standard safety procedures, including, but not limited to, OSHA regulations, and disconnect / lock out / tag out procedures for all utilities including steam, and disconnect / lock out / tag out procedures for gas, electric, and steam powered equipment and / or appliances.

All utilities (gas, electric, water and steam) should be turned OFF to the equipment and locked out of operation according to OSHA approved practices during any servicing of Cleveland Range equipment

Qualified Cleveland Range, LLC Authorized Service Representatives are obligated to maintain up-to-date knowledge, skills, materials and equipment.

Ce document est destiné à l'usage des Représentants de Service qualifiés et autorisés de Cleveland Range, LLC qui possèdent l'expérience et la formation ainsi que la bonne connaissance des mesures de sécurité et du matériel qu'ils entretiennent.

Cleveland Range, LLC décline toute responsabilité pour tout cas de décès, blessure, dommage matériel ou dommage aux biens résultant de l'utilisation, de la mauvaise utilisation ou du manquement d'utilisation des renseignements contenus dans ce document.

Cleveland Range, LLC s'est efforcé à fournir des renseignements précis dans ce document mais ne peut garantir que ce document soit exempt d'erreurs et d'omissions non intentionnelles.

Les renseignements contenus dans ce document peuvent être assujettis à des changements techniques et technologiques, des révisions ou des mises à jour.

Cleveland Range, LLC décline toute obligation ou responsabilité concernant les errata, modifications, révisions ou mises à jour.

Les Représentants de Service qualifiés et autorisés de Cleveland Range, LLC sont tenus de se conformer aux mesures de sécurité normalisées de l'industrie, y compris, mais sans s'y limiter, les réglementations de l'OSHA, les procédures de débranchement / verrouillage / étiquetage relatives à tous les services publics, dont l'approvisionnement en vapeur, et les procédures de débranchement / verrouillage / étiquetage relatives aux équipements et/ou appareils fonctionnant au gaz, à l'électricité et à la vapeur.

Au cours de tout entretien d'un appareil Cleveland Range, tous les services publics (gaz, électricité, eau et vapeur) doivent être FERMÉS au niveau de l'appareil et le dispositif de fonctionnement doit être verrouillé suivant les pratiques approuvées de l'OSHA.

Les Représentants de Service qualifiés et autorisés de Cleveland Range, LLC sont tenus d'actualiser en permanence leurs connaissances, compétences, matériel et équipement.

Este documento está destinado para el uso de los Representantes de Servicio calificados y autorizados de Cleveland Range, LLC quienes cuentan con la experiencia y la capacitación así como el buen conocimiento de las medidas de seguridad y de los equipos que mantienen.

Cleveland Range, LLC, declina toda responsabilidad en caso de cualquier fallecimiento, lesiones, daños al equipo o daños a la propiedad resultantes de la utilización, del uso indebido o de la falta de utilización de la información provista en este documento.

Cleveland Range, LLC se ha esforzado en suministrar información precisa en este documento, pero no puede garantizar que este documento esté exento de errores y de omisiones no intencionales.

La información contenida en este documento podría estar sujeta a cambios técnicos o tecnológicos, revisiones o actualizaciones. Cleveland Range, LLC declina toda obligación o responsabilidad con respecto a erratas, modificaciones, revisiones o actualizaciones.

Los Representantes de Servicio calificados y autorizados de Cleveland Range, LLC tienen la obligación de seguir los procedimientos estándar de seguridad de la industria; los cuales incluyen pero no se limitan a los reglamentos de la OSHA (La Administración de la Seguridad y Salud Ocupacionales), los procedimientos de desconexión, cierre y etiquetado relativos a todos los servicios públicos incluyendo el suministro de vapor y los procedimientos de desconexión, cierre y etiquetado para los equipos y/o aparatos que funcionan a base de gas, electricidad o vapor.

Cuando se esté dando servicio o mantenimiento a un aparato de Cleveland Range, todos los servicios públicos (gas, electricidad, agua y vapor) deben estar APAGADOS para el equipo en cuestión y se debe seguir el procedimiento de cierre de operaciones de acuerdo con las prácticas aprobadas por la OSHA.

Los Representantes de Servicio calificados y autorizados de Cleveland Range, LLC tienen la obligación de actualizar constantemente sus conocimientos, destrezas, materiales y equipamiento.

# **FOR YOUR SAFETY / POUR VOTRE SÉCURITÉ / PARA SU SEGURIDAD**

## **FOR YOUR SAFETY**

**Do not store or use gasoline or any other flammable liquids and vapours in the vicinity of this or any other appliance.**

## **POUR VOTRE SÉCURITÉ**

**Ne pas entreposer ou utiliser d'essence ou d'autres liquides ou vapeurs inflammables à proximité de cet appareil ou de tout autre appareil.**

## **PARA SU SEGURIDAD**

**No guarde ni use gasolina o cualesquiera otros líquidos o vapores inflamables en las cercanías de éste o cualquier otro aparato.**

**WARNING: Improper installation, operation, adjustment, alteration, service or maintenance can cause property damage, injury or death. Read the installation and operating instructions thoroughly before installing, operating or servicing this equipment.**

**AVERTISSEMENT : Toute mauvaise pratique en matière d'installation, de fonctionnement, de réglage, de modification, d'entretien ou de maintenance peut causer des dommages matériels, des blessures ou la mort. Lisez la totalité des instructions d'installation et d'utilisation avant d'installer, d'utiliser ou d'entretenir cet équipement.**

**ADVERTENCIA: La indebida instalación, operación, ajuste, modificación, servicio o mantenimiento puede ocasionar daños a la propiedad, lesiones o muerte. Lea detenidamente las instrucciones de instalación y de operación antes de instalar, poner a funcionar o dar servicio a este equipo.**

Do not spray aerosols in the vicinity of this appliance while it is in operation.

This appliance is not to be used by persons with reduced physical, sensory or mental capabilities, or lack of experience and knowledge, unless they have been given supervision or instruction concerning use of the appliance by a person responsible for their safety.

This appliance is not for use by children and they must be supervised not to play with it.

Retain this manual for your reference.

Ne pas pulvériser des aérosols dans le voisinage de cet appareil alors qu'il est en fonctionnement.

Cet appareil ne doit pas être utilisé par des personnes dont les capacités physiques, sensorielles ou mentales sont réduites, ou des personnes dénuées d'expérience ou de connaissance, sauf si elles ont pu bénéficier, par l'intermédiaire d'une personne responsable de leur sécurité, d'une surveillance ou d'instructions préalables concernant l'utilisation de l'appareil.

Cet appareil n'est pas destiné à être utilisé par des enfants et ils doivent être surveillés pour s'assurer qu'ils ne jouent pas avec l'appareil.

Conservez ce manuel pour votre référence.

No pulverice aerosoles en las proximidades de este aparato mientras está en funcionamiento.

Este aparato no debe ser utilizado por personas con capacidades físicas, sensoriales o mentales reducidas, o que no tengan la experiencia y los conocimientos adecuados, a menos que estas personas hayan recibido supervisión e instrucciones en cuanto al uso del aparato por la persona responsable de la seguridad de ellas.

Guarde este manual para su referencia.



## WARNING / AVERTISSEMENT / ADVERTENCIA



Improper installation, operation, adjustment, alteration, service or maintenance can cause property damage, injury or death. Read the installation and operating instructions thoroughly before installing, operating or servicing this equipment. / Toute mauvaise pratique en matière d'installation, de fonctionnement, de réglage, de

modification, d'entretien ou de maintenance peut causer des dommages matériels, des blessures ou la mort. Lisez la totalité des instructions d'installation et d'utilisation avant d'installer, d'utiliser ou d'entretenir cet équipement. / La indebida instalación, operación, ajuste, modificación, servicio o mantenimiento puede ocasionar daños a la propiedad, lesiones o muerte. Lea detenidamente las instrucciones de instalación y de operación antes de instalar, poner a funcionar o dar servicio a este equipo.



Do not lean on or place objects on lip. / Ne vous penchez pas sur ou ne placez pas des objets sur la lèvres. / No se apoye ni coloque objetos en el labio.



Hot product and surfaces. / Produit et surfaces chaudes. / Producto y superficies calientes.

Do not touch. / Ne pas toucher. / No la toque



Stand clear of product discharge path when discharging hot product. / Écartez-vous du chemin de décharge d'un produit chaud. / Permanezca alejado de la ruta de descarga del producto al vaciar producto caliente.



Keep hands away from moving parts and pinch points. / Gardez les mains loin des pièces mobiles et des points de pincement. / Mantenga las manos lejos de piezas móviles y puntos de presión muy localizada.



Inspect unit daily for proper operation. / Inspectez l'unité tous les jours pour son bon fonctionnement. / Inspeccione diariamente el funcionamiento correcto de la unidad.



Remove electrical power prior to servicing. / Coupez l'alimentation électrique avant l'entretien. / Desconecte la energía eléctrica antes de darle servicio.

Risk of electric shock. / Risque de choc électrique. / Riesgo de choque eléctrico.



Pressurized device. / Appareil sous pression. / Dispositivo de presión.

Keep clear of pressure relief discharge. / Restez à l'écart de la soupape de sûreté. / Permanezca alejado de la descarga de presión.



Do not climb, sit or stand on equipment. / Il ne faut pas monter, s'asseoir ni se tenir debout sur l'équipement. / No subirse, ni sentarse ni pararse sobre el equipo.



Surfaces and product may be hot! Wear protective equipment. / Les surfaces et le produit peuvent être chauds! Portez un équipement de protection. / ¡Las superficies y el producto pueden estar calientes! Utilice equipo protector.



Floor may become slippery from product spillage. / Déversement de produit peut causer de plancher à être glissant. / Derrame de producto puede causar piso a ser resbaladizo.



Unit must be anchored as per manual. / Unité doit être ancrée selon les directives du manuel. / Unidad debe estar fijado según el manual.



Do not fill kettle above recommended level marked on outside of kettle. / Ne remplissez pas la chaudière en excès du niveau recommandé marqué sur la chaudière. / No llene la marmita arriba del nivel recomendado marcado fuera de la marmita.



Heavy / Lourd / Pesado

Team or mechanical lift. / Équipe ou remontée mécanique. / Equipo o elevador mecánico.

## SERVICING / ENTRETIEN / SERVICIO



Have a qualified service technician maintain your equipment. / Demandez à un technicien en entretien et en réparation qualifié d'effectuer l'entretien de votre équipement. / Haga que un técnico de servicio calificado mantenga su equipo



Ensure kettle is at room temperature and pressure gauge is showing zero or less prior to removing any fittings. / Assurez-vous que la chaudière est à température ambiante et que le manomètre est à zéro ou moins avant de retirer des accessoires. / Asegúrese de que la marmita esté a temperatura ambiente y el manómetro esté mostrando cero o menos antes de retirar cualquier accesorio.

# INSTALLATION

## GENERAL

Installation of the kettle must be accomplished by qualified electrical installation personnel working to all applicable local and national codes. Improper installation of product could cause injury or damage.

This equipment is built to comply with applicable standards for manufacturers. Included among those approval agencies are: UL, NSF, ASME/Ntl. Bd., CSA, CGA, ETL, and others. Many local codes exist, and it is the responsibility of the owner/installer to comply with these codes.

## RECEIVING INSPECTION

Before unpacking visually inspect the unit for evidence of damage during shipping.

If damage is noticed, do not unpack the unit, follow Shipping Damage Instructions shown below.

## SHIPPING DAMAGE INSTRUCTIONS

If shipping damage to the unit is discovered or suspected, observe the following guidelines in preparing a shipping damage claim.

1. Write down a description of the damage or the reason for suspecting damage as soon as it is discovered. This will help in filling out the claim forms later.
2. As soon as damage is discovered or suspected, notify the carrier that delivered the shipment.
3. Arrange for the carrier's representative to examine the damage.
4. Fill out all carrier claims forms and have the examining carrier sign and date each form.

## APPROXIMATE WEIGHTS

Model #	Unit	Unit with shipping box
KEL-25	210 lbs.	245 lbs.
KEL-30	230 lbs.	265 lbs.
KEL-40	280 lbs.	315 lbs.
KEL-60	330 lbs.	365 lbs.
KEL-80	385 lbs.	420 lbs.
KEL-100	415 lbs.	450 lbs.
KEL-25-T	290 lbs.	325 lbs.
KEL-40-T	360 lbs.	395 lbs.
KEL-60-T	415 lbs.	450 lbs.
KEL-80-T	470 lbs.	505 lbs.
KEL-100-T	520 lbs.	555 lbs.
KEL-40-TSH	360 lbs.	395 lbs.
KEL-60-TSH	415 lbs.	450 lbs.
KEL-40-SH	280 lbs.	315 lbs.
KEL-60-TSH	340 lbs.	375 lbs.



## UNCRATING

### Caution:

Straps under tension and will snap when cut.

Carton may contain staples and skid contains nails.

Use proper safety equipment and precautions.

Unit is heavy use adequate help or lifting equipment as needed.

1. Carefully cut any straps from container.
2. Lift off carton.
3. Inspect for hidden damage. If found refer to "SHIPPING DAMAGE INSTRUCTIONS".
4. Cut strap holding unit.
5. Remove manual from kettle pot. Write down the model # and serial # of the unit onto the front of this manual.
6. Lift kettle off skid and move kettle to its installation location.
7. Discard packaging material according to local and or state requirements.

## VENTILATION

Operation of these units can produce significant levels of steam and condensate, it is recommended they be installed under a ventilation hood in a room which has provisions for adequate make up air. Further information can be obtained by referring to the U.S.A. National Fire Protection Associations NFPA96 regulations. These standards have also been adopted by the National Building Code in Canada.

## POSITIONING

The first installation step is to refer to the Specification Sheets or Specification Drawings for detailed clearance and drain requirements in order to determine the location of the kettle. Next, carefully cut open the shipping carton for easy removal of the kettle.

Position the kettle in it's permanent location, and level the kettle by turning the adjustable flanged feet. Once positioned and leveled, permanently secure the kettle's flanged feet to the floor using 5/16" lag bolts and floor anchors (supplied by the installer). There are three bolts required to secure each of the flanged feet.

## CLEARANCE REQUIREMENTS

Back - 0, Left Side - 0, Right Side - 12" (Minimum recommended clearance for service)

## ELECTRICAL



Install in accordance with local codes and/or the National Electric Code ANSI/NFPA No. 70-1990 (USA) or the Canadian Electric Code CSA Standard C22.1 (Canada). A separate fused disconnect switch must be supplied and installed. The kettle must be electrically grounded by the installer.

The electrical supply must match the power requirements specified on the kettle's rating plate. The copper wiring must be adequate to carry the required current at the rated voltage.

Note: Maximum voltage for LVD (low voltage directive for Europe) to be 440 volts for CE marked appliances.

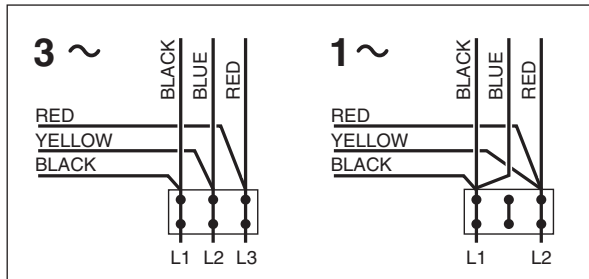

The kettle is wired for 3-phase operation at the factory. For single phase operation, rewire the terminal block to that shown in the above diagram.

Note: Ensure main power is turned off before connecting wires.

### Stationary Models

Remove the screws securing the dome-shaped service cover underneath the kettle and remove the cover. A wiring diagram is affixed to the inside of cover. Fasten permanent copper wiring to the three-connection terminal block. Be sure to connect ground wire to the separate ground terminal connector (ground lug). Slide the cover's slot over the wiring and secure the cover to kettle with the screws.

### Tilting Models

First remove the handwheel by loosening the allen screw. Then remove the two screws at the front and rear of the console cover and remove the cover. A wiring diagram is affixed to the underside of the console cover. Feed permanent copper wiring through the cut-out in the bottom of the console, and fasten to the three-connection terminal block. Be sure to connect the ground terminal connector (ground lug). Replace the console cover and handwheel.

## INSTALLATION CHECKS

Although the kettle has been thoroughly tested before leaving the factory, the installer is responsible for ensuring the proper operation of kettle once installed.



### Visual Checks

1. Check Tilting (tilting kettles):
  - A/ Gearbox tilts kettle smoothly and freely.

2. Insure there are:
  - A/ Three lag bolts securely holding each foot
  - B/ The bottom cover (stationary kettles) is in place and held with a nut.
  - C/ The console cover (tilting kettles) is in place and held with a screw.

### Performance Checks

1. Supply power to the kettle by placing the fused disconnect switch to the "ON" position.

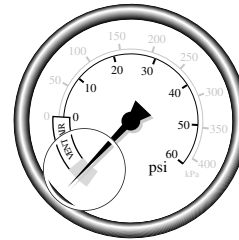

2. Before turning the kettle on, read the Vacuum/Pressure Gauge. The gauge's needle should be in the green zone. If the needle is in the "VENT AIR" zone, follow Kettle Venting Procedure in the Service Manual.
3. Turn the kettle's ON/OFF Switch/Solid State Temperature Control to "1" (Min.). The Heat Indicator Light (Green) should remain lit, indicating the element is on, until the set temperature is reached (130°F/54°C). Then the green light will cycle on and off, indicating the element is cycling on and off to maintain temperature.
4. Tilt the kettle forward (tilting models only). After a few moments the Low Water Indicator Light (Red) should be lit when the kettle is in a tilted position. This light indicates that the element has automatically been shut off by the kettle's safety circuit. This is a normal condition when the kettle is in a tilted position.
5. Raise the kettle to the upright position. The Low Water Indicator Light (Red) should go out when the kettle is upright.
6. Turn the ON/OFF Switch/Solid State Temperature Control to "10" (Max.) and allow the kettle to preheat. The green light should remain on until the set temperature (260°F/127°C) is reached. Then the green light will cycle ON and OFF, indicating the element is cycling ON and OFF to maintain temperature. Fill the kettle with cold water to the steam jacket's welded seam. Refer to the Temperature Range Chart for the time required to bring the water to a boil.
7. When all testing is complete, empty the kettle and turn the ON/OFF Switch/Solid State Temperature Control to the "OFF" position.

## CLEANING

After installation the kettle must be thoroughly cleaned and sanitized prior to cooking.

# OPERATING INSTRUCTIONS



## WARNING / AVERTISSEMENT / ADVERTENCIA

If for any reason this unit is not functioning correctly **DO NOT OPERATE**.  
Contact your authorized service agent.



Temperature Control Setting	Approximate Product Temperature °F	Approximate Product Temperature °C
<b>MIN.</b>	120	49
<b>1.</b>	130	54
<b>2.</b>	145	63
<b>3.</b>	160	71
<b>4.</b>	170	77
<b>5.</b>	185	85
<b>6.</b>	195	91
<b>7.</b>	210	99
<b>8.</b>	230	110
<b>9.</b>	245	118
<b>MAX.</b>	265	130

**NOTE:** Certain combinations of ingredients will result in temperature variations

Temperature Range Chart

## OPERATING THE KETTLE

**NOTE:** If you are cooking an egg or milk product, do not pre-heat kettle.

### ITEM # DESCRIPTION

- 1. On-Off Switch/Solid State Temperature Control** - Turns kettle ON/OFF and allows the operator to adjust the kettle temperature in increments from 1 (Min.) to 10 (Max.). (see Temperature Range Chart in the Operating Instructions section).
- 2. Heat Indicator Light (Green)** - When lit, indicates that the kettle element is on. Cycles ON-OFF with element.
- 3. Low Water Indicator Light (Red)** - When lit, indicates that the kettle is low on water and will not operate in this condition. This will also light when the kettle is tilted.
- 4. Vacuum/Pressure Gauge** - Indicate steam pressure in PSI inside steam jacket as well as vacuum in inches of mercury.
- 5. Pressure Relief Valve (not shown)** - This valve is used to vent the kettle and in the unlikely event there is an excess steam build-up in the jacket, this valve opens automatically to relieve this pressure.
- 6. Tilt Wheel** - Used for tilting the kettle up or down. Some units have an optional Power Tilt Control Switch located in the same position.
- 7. Power Tilt Control Switch (not shown)** - Used for tilting the kettle up or down.
- 8. Tangent Draw-Off Valve** - Used for draining product or wash water from kettle. It is supplied as standard equipment on stationary kettles and is optional on tilting kettles.

- Perform DAILY PRE-STARTUP INSPECTION (see Maintenance).
- Preheat the kettle by turning the dial to the desired temperature setting (see "Temperature Range Chart"). The Heat Indicator Light (Green) will remain lit, indicating the unit is heating, until the temperature setting is reached. When the green light goes off, the burners are off, and preheating is complete.
- Place food product into the kettle. The Heat Indicator Light (Green) will cycle on and off indicating the burners are cycling on and off to maintain the set temperature.

**NOTE:** Do not fill kettle above recommended level marked on outside of kettle.



- When cooking is completed turn dial to the "OFF" position.

**NOTE:** A five minute complete shut-of period is required before relighting.

- Pour the contents of the kettle into an appropriate container by tilting the kettle forward. Care should be taken to pour slowly enough to avoid splashing off the product.

# CLEANING INSTRUCTIONS



## CARE AND CLEANING

Cooking equipment must be cleaned regularly to maintain its fast, efficient cooking performance and to ensure its continued safe, reliable operation. The best time to clean is shortly after each use (allow unit to cool to a safe temperature).

## WARNINGS



Chloride Cleaners

Do not use detergents or cleansers that are chloride based or contain quaternary salt.



Wire Brush & Scrapers

Do not use a metal bristle brush or scraper.



Steel Pads

Steel wool should never be used for cleaning the stainless steel.



High Pressure Spray Hose

Unit should never be cleaned with a high pressure spray hose.



Stagnant Water

Do not leave water sitting in unit when not in use.

## CLEANING INSTRUCTIONS

1. Turn unit off.
2. Remove drain screen (if applicable). Thoroughly wash and rinse the screen either in a sink or a dishwasher.
3. Prepare a warm water and mild detergent solution in the unit.
4. Remove food soil using a nylon brush.
5. Loosen food which is stuck by allowing it to soak at a low temperature setting.
6. Drain unit.
7. Rinse interior thoroughly.
8. If the unit is equipped with a **Tangent Draw-Off Valve**, clean as follows:
  - a) Disassemble the draw-off valve first by turning the valve knob counter-clockwise, then turning the large hex nut counter-clockwise until the valve stem is free of the valve body.
  - b) In a sink, wash and rinse the inside of the valve body using a nylon brush.
  - c) Use a nylon brush to clean tangent draw-off tube.
  - d) Rinse with fresh water.
  - e) Reassemble the draw-off valve by reversing the procedure for disassembly. The valve's hex nut should be hand tight only.
9. If the unit is equipped with a **Butterfly Valve**, clean as follows:
  - a) Place valve in open position.
  - b) Wash using a warm water and mild detergent solution.
  - c) Remove food deposits using a nylon brush.
  - d) Rinse with fresh water.
  - e) Leave valve open when unit is not in use.
10. If the unit is equipped with an **Air Valve**, clean as follows:
  - a) Open product valve.
  - b) Disconnect air hoses.
  - c) Remove air cylinder.
  - d) Remove valve tee.
  - e) Remove all O-rings.
  - f) Clean air cylinder, do not submerge in water. Wipe clean and sanitize.
  - g) Clean and sanitize tee and O-rings.
  - h) Grease and reinstall O-rings.
  - i) Reinstall valve tee to kettle outlet.
  - j) Reinstall air cylinder to bottom of tee.
  - k) Reconnect air hoses.
  - l) Close valve and check for alignment.
11. Using mild soapy water and a damp sponge, wash the exterior, rinse, and dry.

## NOTES

- ⇒ For more difficult cleaning applications one of the following can be used: alcohol, baking soda, vinegar, or a solution of ammonia in water.
- ⇒ Leave the cover off when the kettle is not in use.
- ⇒ For more detailed instructions refer to Stainless Steel Equipment Care and Cleaning ([www.nafem.org/resources/stainlesssteelfinal.doc](http://www.nafem.org/resources/stainlesssteelfinal.doc)) on Nafem's website ([www.nafem.org](http://www.nafem.org)).

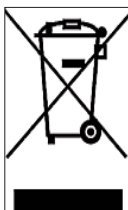

## DISPOSAL INSTRUCTIONS

This unit is recyclable. Do not dispose in landfill.

The unit may contain rust inhibitor and or antifreeze within the jacket. Drain unit and dispose following Federal, State and local regulations.

The majority of the unit is composed of stainless steel. Other alloys and electrical components make up a small percentage of the total. Follow Federal, state and local regulations for disposal.



# PREVENTATIVE MAINTENANCE

ALL SERVICE MUST BE PERFORMED BY A QUALIFIED SERVICE TECHNICIAN.



**! WARNING / AVERTISSEMENT / ADVERTENCIA**

If for any reason this unit is not functioning correctly  
**DO NOT OPERATE.** Contact your authorized service agent.

Refer to maintenance procedures and parts list manual for detailed maintenance and testing instructions.



## DAILY PRE-STARTUP INSPECTION

1. Kettle tilts smoothly, handle is tight and kettle holds in any position (tilting models only).
2. Pressure gauge is in the green when unit is cold.
3. Green light comes on when unit is energized.
4. Red light comes on when unit is tilted (tilting models only).
5. Cover is held in position by spring when raised (spring assisted covers only).
6. Cover is held securely to handle, knob is on the end of the handle.

## SIX MONTH SERVICE INSPECTION

1. Perform daily startup inspection.
2. Grease bearings on both trunnions.
3. Inspect worm and gear for tightness and grease.
4. Perform pressure relief valve periodic test (see Pressure Relief Valve Testing).
5. Check that both bottom cover gaskets are in place and are not cracked or split.
6. Check that unit is bolted in place.
7. Insure there are two screws firmly holding down the cover. If not replace screws.
8. Check hand wheel for tightness. If loose tighten Allen screw.
9. Check spring assist hinge screws are tight (for cover).

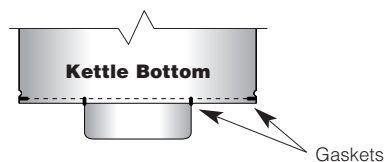

## YEARLY SERVICE INSPECTION

1. Perform six month service inspection.
2. Check kettle maximum temperature setting (see CALIBRATING PROCEDURE).
3. Perform safety inspection using SAFETY INSPECITON CHECKLIST found in the MAINTENANCE PROCEDURES.



# TROUBLESHOOTING AND MAINTENANCE PROCEDURES



*The following trouble shooting guide and maintenance procedures are meant to be used by Qualified Service Technician*

**ANY REPAIRS TO THE PRESSURE VESSEL MUST BE DONE BY A CERTIFIED PRESSURE VESSEL REPAIR SHOP AND ALL REPAIR METHODS AND MATERIALS MUST BE APPROVED BY THE MANUFACTURER.**

**For periodic maintenance recommendations see “Operators Manual”.**

**Extreme caution must be taken if unit is electrically energized for testing.**

**Remove power from the unit while servicing.**

## DIAGNOSTIC GUIDE

This section contains servicing information intended for use by Authorized Service Personnel.

**NOTE 1:** If Fault Isolation Procedure is required, be sure to start at step #1.

**NOTE 2:** On table type kettles the entire control mounting panel may be removed from kettle control housing for easier troubleshooting and parts replacement.

**A/ Problem:** Kettle is not heating at all. (Kettle must be on and temperature control set.)

### Possible Causes

- |                                    |  |  |
|------------------------------------|--|--|
| <b>1.</b> No incoming power.       | <b>5.</b> Defective 12 VDC relay.          | <b>10.</b> Defective thermistor.             |
| <b>2.</b> Kettle is tilted.        | <b>6.</b> Defective safety thermostat.     | <b>11.</b> Defective 240/16 VAC transformer. |
| <b>3.</b> Low water condition.     | <b>7.</b> Defective contactor/s.           | <b>12.</b> Defective control box.            |
| <b>4.</b> Defective ON/OFF switch. | <b>8.</b> Defective potentiometer.         | <b>13.</b> Defective elements.               |
|                                    | <b>9.</b> Defective low water level probe. |  |

### Fault Isolation Procedure

#### Step Test

<b>1.</b>	Is there proper incoming voltage at terminal block?
Yes	Go to step #2.
No	Correct external power supply problem.
<b>2.</b>	Is the red LED illuminated?
Yes	Follow Reservoir Fill Procedure. If this does not correct the problem, go to Problem <b>D</b> .
No	Go to step #3
<b>3.</b>	Is the green LED illuminated?
Yes	Go to step #4.
No	Go to step #7.
<b>4.</b>	Do both contactors energize?
Yes	Check contactor contacts for pitting. Voltage across contactor terminals while in a closed position indicates a poor contact. Replace contactor/s as necessary. Check elements for short at ground or an open circuit. If element/s are defective contact the factory. Elements are not field replaceable.
No	Go to step #5.
<b>5.</b>	Measure continuity across safety thermostat. Is it an open circuit?
Yes	Replace defective safety thermostat.
No	Go to step #6.
<b>6.</b>	Is there 120 VAC present across the coils of the contactors?
Yes	Replace defective contactor/s.
No	Go to step #7.
<b>7.</b>	Remove wire from low water level probe and ground it to the body of the kettle. Do the contactors now energize?
Yes	Clean or replace defective low water level probe. Replace defective red LED.
No	Go to step #8.
<b>8.</b>	Is there 16VAC present at output of 16 VAC transformer?
Yes	Go to step #9.
No	Replace defective 240/16 VAC transformer.
<b>9.</b>	Measure continuity of ON/OFF switch. Is it operating properly?
Yes	Go to step #10.
No	Replace defective ON/OFF switch.

<b>10.</b>	Unplug control box and measure the resistance across potentiometer. Is it approximately 0 ohms at maximum setting and 50,000 ohms at minimum?
Yes	Go to step <b>#11</b> .
No	Replace defective potentiometer.
<b>11.</b>	Remove edge connector from control box. While kettle is cold or thermistor is removed and allowed to cool, measure the resistance between edge connector's pins #2 and #7. Is it approximately 100,00 ohms?
Yes	Spray contact cleaner on control box terminals and edge connector. Try box again, if the problem still exists, replace defective control box.
No	Replace defective thermistor.

**B/ Problem:** Kettle heats too slowly or not hot enough. (**Note:** normal max. operating pressure with an empty kettle is 30-35 psi.)

**Possible Causes**

- |   |                                    |                                  |
|---|------------------------------------|----------------------------------|
| <b>1.</b> Air in jacket requires venting. | <b>3.</b> Defective potentiometer. | <b>6.</b> Defective control box. |
| <b>2.</b> Defective safety thermostat.    | <b>4.</b> Defective thermistor.    | <b>7.</b> Defective elements/s.  |
|   | <b>5.</b> Defective contactor/s.   |                                  |

**Fault Isolation Procedure**

Step	Test
<b>1.</b>	In a cold state, does the pressure gauge read in the green zone?
Yes	Go to step <b>#2</b> .
No	There is air present in the jacket of the kettle. Follow Kettle Venting Procedure. If constant venting is required, there is a leak that should be corrected.
<b>2.</b>	Do the contactors shut off too early? (before reaching normal maximum operating pressure.)
Yes	Go to step <b>#3</b> .
No	Check contactor contacts for pitting. Voltage across terminal of contactor while energized signifies a poor contact. Replace contactor/s as necessary. Check elements for short to ground or open circuit. If elements are defective, contact the factory. Elements are not field replaceable.
<b>3.</b>	Does the green LED remain illuminated after the contactors shut off?
Yes	Replace defective safety thermostat.
No	Go to step <b>#4</b> .
<b>4.</b>	Unplug control box and measure the resistance across potentiometer. Is it approximately 0 ohms at maximum and 50,000 ohms at minimum setting?
Yes	Go to step <b>#5</b> .
No	Replace defective thermistor.
<b>5.</b>	Remove kettle thermistor and allow to cool. Remove edge connector from control box. Test resistance across edge connector's pins #2 and #7. Is it approximately 100,000 ohms?
Yes	Go to step <b>#6</b> .
No	Replace defective thermistor.
<b>6.</b>	Turn the potentiometer on the control box clockwise to increase the maximum operating temperature. Does the kettle now achieve maximum operating pressure of 30-35 psi in an empty kettle?
Yes	Kettle is operating correctly.
No	Spray contact cleaner on control terminals and edge connector. Try box again. If problem still exists, replace defective control box.

**C/ Problem:** Kettle is overheating.

**Possible Causes**

- |                                    |                                   |
|------------------------------------|-----------------------------------|
| <b>1.</b> Defective thermistor     | <b>3.</b> Defective 12 VDC relay. |
| <b>2.</b> Defective potentiometer. | <b>4.</b> Defective control box.  |

**Fault Isolation Procedure**

Step	Test
<b>1.</b>	Does the green LED turn off even though the contactors remain energized?
Yes	Replace defective 12 VDC relay.
No	Go to step <b>#2</b> .
<b>2.</b>	Unplug the control box and measure the resistance across the potentiometer, Is the resistance approximately 0 ohms at maximum and 50,000 ohms at minimum setting?
Yes	Go to step <b>#3</b> .
No	Replace defective thermistor.

- 3.** Remove kettle thermistor and allow to cool Remove edge connector from control box. Test resistance across edge connector's pins #2 and #7. Is it approximately 100,000 ohms?  
 Yes Go to step #4.  
 No Replace defective thermistor.
- 
- 4.** Turn the potentiometer on the control box counter-clockwise to decrease the maximum operating temperature. does the kettle continue to overheat?  
 Yes Spray contact cleaner on control box terminal and edge connector. Try box again. If problem still exists, replace defective control box.  
 No Kettle is operating correctly.
- 

**D/ Problem:** Red LED remains illuminated even though water has been added.

**Possible Causes**

- 1.** Defective low water level probe                      **2.** Defective control box.

**Fault Isolation Procedure**

**Step Test**

- 1.** Remove wire from low water level probe and ground the wire to the body of the kettle. Does the red LED turn off?  
 Yes Replace or clean defective low water level probe.  
 No Spray contact cleaner on control box terminals and edge connector. Try box again. If problem still exist, replace defective control box.
- 

**SAFETY INSPECTION CHECKLIST**

**NOTE:** The following instructions are intended for use by qualified service personnel. The following steps should be completed **IN SEQUENCE.**



**A/ KETTLE PREPARATION**

- 1. Disconnect main power at fused disconnect switch.**
- 2.** Kettle should be cold. If necessary add water to kettle pot to cool unit.
- 3.** The pressure gauge should now show a vacuum and have no indication of leakage. If gauge looks damaged replace gauge.
- 4.** Gauge must be showing a vacuum prior to proceeding. If not check for leaks, and repair kettle prior to proceeding. Refer to REFERENCE SECTION (KETTLE VENTING INSTRUCTIONS).



Pressure Gauge in Vacuum.

**B/ MECHANICAL CHECKS**

- 1.** Inspect controls, replace damaged seals, switches, LED's etc..
  - 2.** Remove the console cover and check that the seal is not cracked or split. Replace seal, screws, missing or worn nylon anchor nuts. **Leave cover off.**
  - 3.** Remove the kettle bottom cover and check that the seal is not cracked or split. **Leave cover off.**
- 4A. For units with tilt handle-**
- A. Check handle for tightness. If loose apply lock tight and reinstall. Check handle knob is on end of handle and firmly tightened. If missing replace, if loose apply lock tight and reinstall.
  - B. Check that kettle tilts smoothly and there is no excessive wear in the trunnion bearings. Add grease to nipples as required.

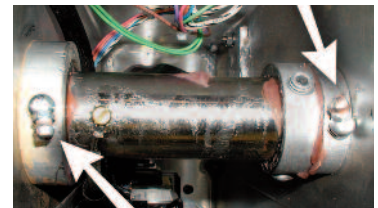

Grease Nipples.

**4B. For units with tilt crank-**

- A. Check that the kettle tilts smoothly. If there is excess play adjust the worm to gear clearance with Locking Nuts or Adjusting Screw as required.
- B. Check that there is no excessive wear in the trunnion bearings.
- C. Apply grease to gear teeth and bearings.

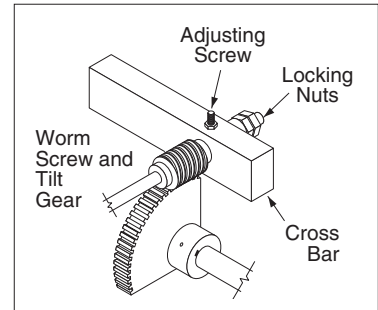
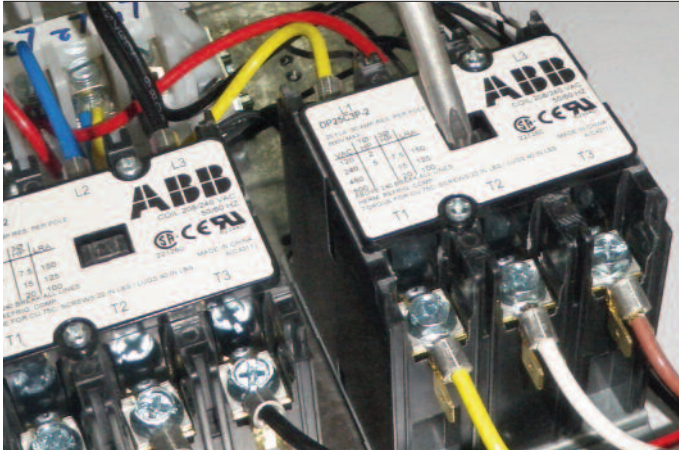

Illustration inverted for clarity.



## C/ CONTACTOR TEST

1. Remove power to unit.
2. Remove nut holding component mounting plate to console.
3. Pull plate out and place on top of console. (Depending on how the installer wired the kettle you may have to remove the supply wire and reconnect).
4. Physically push in on contacts of each contactor to check for free movement. Replace contactor(s) if required.

## D/ LOW WATER LEVEL PROBE:

### Installation Check:

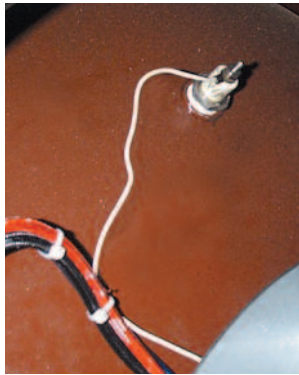

✓ Probe properly attached

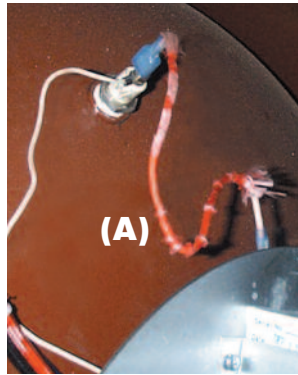

✗ Probe bypassed by running (A) an additional wire

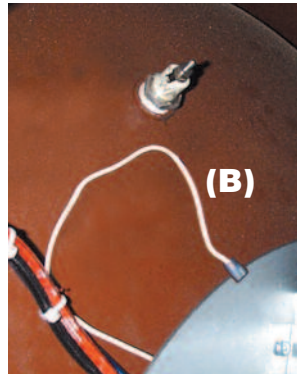

✗ Probe bypassed by (B) grounding the connecting wire

### Functional Test:

1. Turn main power on at fused disconnect switch.
2. Turn kettle on and set temperature to maximum.
3. Green light will come on and contactors close.
4. Tilt kettle over. After approximately a five-second delay the red light will come on, green light go off and the contactors will disengage.
5. Turn kettle upright. Green light will come back on and contactors reengage.
6. Turn kettle off
7. If unit does not function as above, make required repairs.
8. Disconnect main power at fused disconnect switch.

## E/ SAFETY THERMOSTAT

### Installation Check:

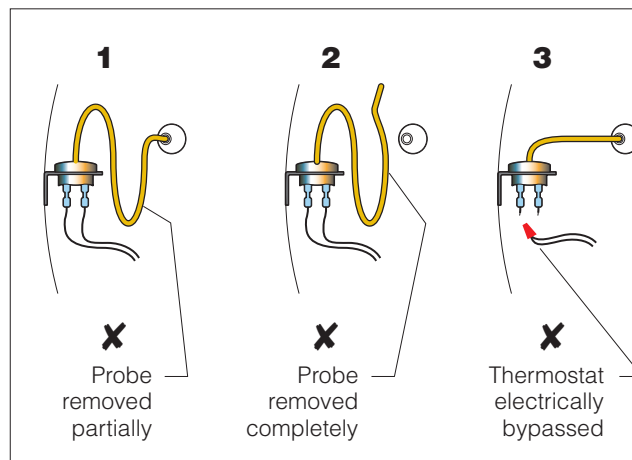
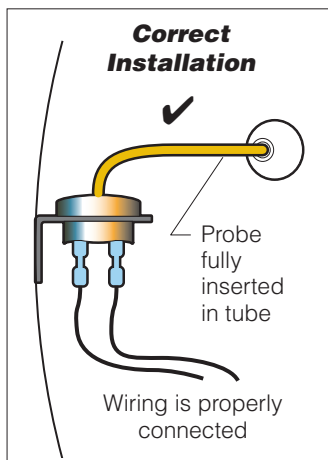

### Incorrect Installations

1. Safety thermostat probe is not completely inserted into tubing (except KET-3-T that has a small loop).
2. Safety thermostat probe is removed from tubing.
3. Safety thermostat electrical connection is bypassed.

## F/ SAFETY VALVE



### Installation Check:

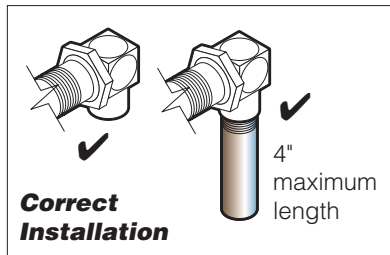

The above illustrations show the variations of factory installed Safety Valves. **Any modifications are unacceptable.**

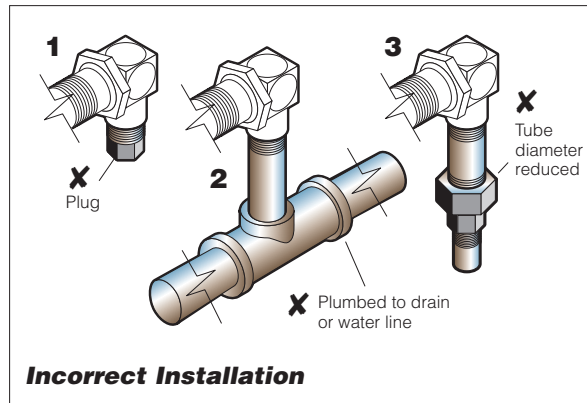

### Physical Checks

1. Check that the PSI rating on the valve matches MAWP (maximum allowable working pressure) on the plate welded to the kettle.
  2. Check that the Safety Valve has a "UV" stamp.
  3. Check that the valve is not damaged in any way.
- If any of the above criteria is not met, replace valve.

### Pressure Relief Valve Periodic Testing Procedure

1. With the kettle empty, set On-Off Switch/Temperature Control to "10" (Max.). Allow the kettle to heat until the unit cycles off.
2. Switch On-Off Switch/Temperature Control to "0" (Off) and disconnect main power at fused disconnect switch.
3. Stand to the side of the pressure relief valve discharge tube and pull valve open for a maximum of one second. Repeat test three to four times. Each time the mechanism should move freely and be accompanied by a rapid escape of steam.

If valve appears to be sticking replace pressure relief valve.

If foreign material is discharged then drain kettle and replace pressure relief valve.

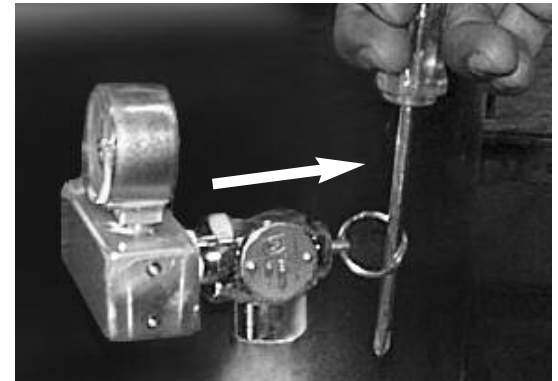

## G/ CALIBRATING PROCEDURE

1. Kettle must be empty when this procedure is executed.
2. Insure the unit has a vacuum before you begin calibrating procedures. If unit requires venting see REFERENCE SECTION (KETTLE VENTING INSTRUCTIONS).
3. Turn kettle ON and set temperature dial to 10 (Max.).
4. Allow the unit to cycle twice (the green light must go on and off).
5. Check temperature of the inner kettle surface with a digital surface thermometer. For accurate readings move probe around bottom of kettle to locate the hottest location.
6. Temperature should be between 260° F and 265° F. Pressure gauge should read between 20 - 28 PSI.
7. Using a screw driver adjust temperature by turning the potentiometer on the black box. Turn very little. Turn clockwise to INCREASES and counter-clockwise to DECREASE temperature.
8. Allow the unit to cycle twice.
9. Re-check temperature.
10. Repeat steps 7 - 9 until unit is calibrated.

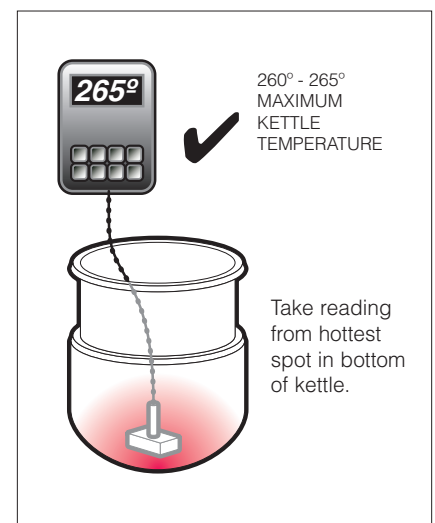

## REPAIRING LEAKS IN STEAM JACKETED KETTLE FITTINGS

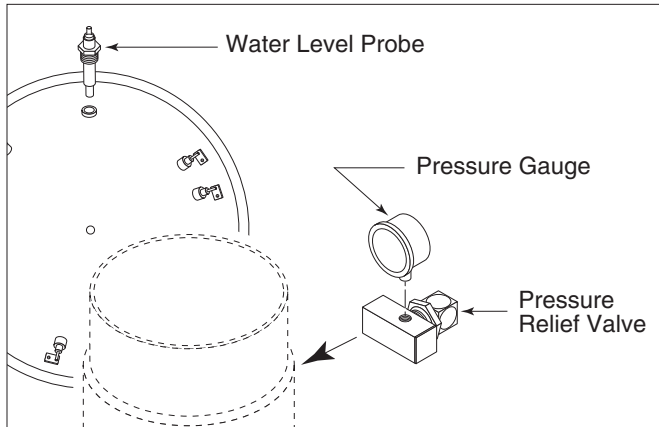

If unit will not hold a vacuum the most likely cause is a leak at one of the fittings. Often, the easiest way to eliminate a leak is reseal the suspect areas.

1. Water Level Probe      Remove, clean threads, apply teflon thread sealant and reinstall.
2. Pressure Relief Valve    **A/** Inspect for signs of leaks. Replace if required.  
    **B/** Remove, clean threads, apply teflon thread sealant and reinstall.
3. Pressure Gauge          **A/** Inspect face of gauge. If it contains moisture on the inside of face replace.  
    **B/** Remove, clean threads, apply teflon thread sealant and reinstall.

## THERMISTOR REPLACEMENT

1. Disconnect main power at fused disconnect switch.
2. Remove bottom cover.

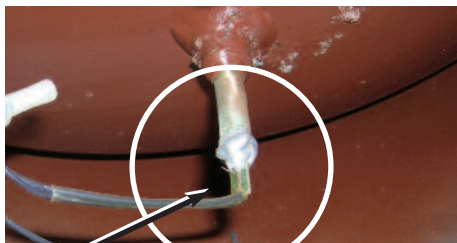

3. Locate thermistor.



4. Cut pigtail connection off.



5. Remove wire from ground lug.
6. Remove thermistor from tube.

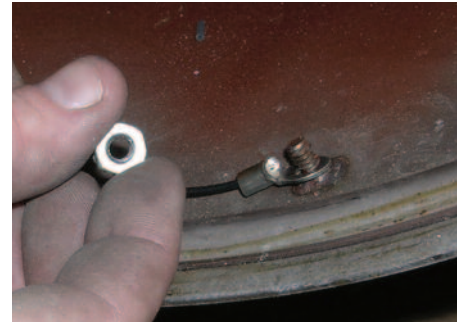

7. Add new "eye" connector to one of the thermistor leads and fasten to ground lug.

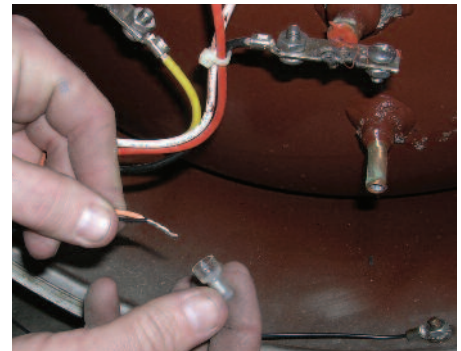

8. Connect orange wire to the other thermistor lead and fasten with pigtail connector.



9. Insert thermistor as far as possible into tube and hold in place. While holding add silicon to secure thermistor into tube. Insure silicon completely surrounds tube and thermistor.
10. Replace covers, reconnect power and test operation.

# KETTLE JACKET CLEANOUT AND PASSIVATION PROCEDURES

The following procedure should be performed at least once every three years to prevent possible corrosion and ensure the optimum life of the kettle.



**DANGER:**



Rust inhibitor can be dangerous. read label and follow safety instructions.

**WARNING:**



Improper refilling of kettle jacket will result in irreversible damage to unit.

## RUST INHIBITOR

Use a "radiator rust inhibitor" that can be purchased at your local automotive centre. It should not contain any anti-freeze and preferably no lubricant.

To ensure satisfactory mixing follow the manufacturer's instructions.

DISPOSAL - Follow all Federal, State and local codes when disposing of product.

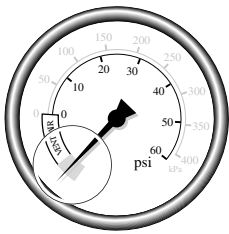

1. Ensure kettle is at room temperature and pressure gauge showing zero or less pressure.
2. Shut off power to the kettle at the fused disconnect switch.

**C. Fill unit via Street Elbow**

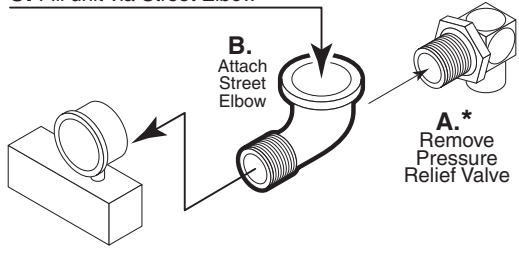

**\*Important-** Pull ring on Pressure Relief Valve prior to removal to insure vessel is not pressurized.

3. Pull Pressure Relief Valve (A) open to insure vessel is not pressurized.
4. Remove Pressure Relief Valve (A).
5. Replace Pressure Relief Valve (A) with Street Elbow (B).
6. Add Spring Water (C) through the Street Elbow (B), using a funnel if necessary. Refer to SPRING WATER REQUIREMENTS chart for the proper amount required.
7. Apply a thread sealant (i.e. Teflon tape) to the Pressure Relief Valve's (A) thread and replace.
8. Restore power to unit at the fused disconnect switch.
9. The kettle must now be vented. (Refer to the KETTLE VENTING INSTRUCTIONS).

## KETTLE VENTING INSTRUCTIONS

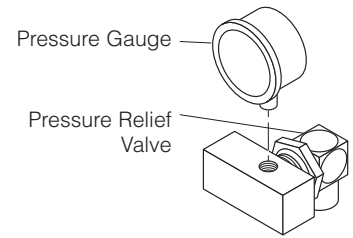
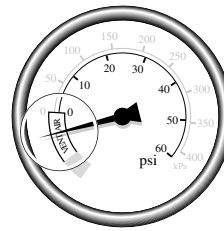

The following venting procedure should be followed when the Vacuum/Pressure Gauge needle is in the "VENT AIR" zone:

NOTE: Check for and eliminate leaks prior to venting (See REPAIRING LEAKS IN STEAM JACKETED KETTLE FITTINGS).

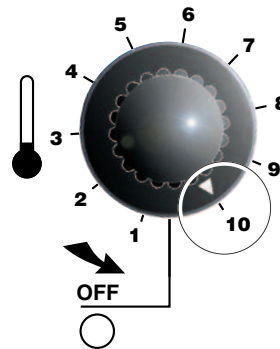

1. Set On-Off Switch/Temperature Control to "10" (Max.). Heat the empty kettle until unit cycles off.

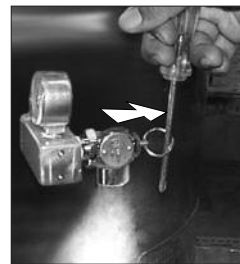

2. Vent kettle by pulling safety valve ring 8-10 times in short 2-3 second blasts with a 5 second interval between pulls.

NOTE: If unit cycles ON, stop venting and wait for kettle to cycle OFF before continuing.

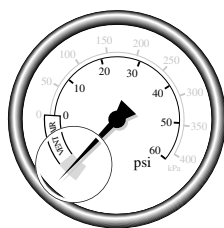

3. Turn kettle OFF. Add cold water to kettle until its surface temperature is below 100°F. The pressure gauge needle should be in the green zone, indicating a vacuum in the kettle's jacket.

## LUBRICATION PROCEDURE

Lubricate the following parts every three months to insure smooth operation and reduce wear.

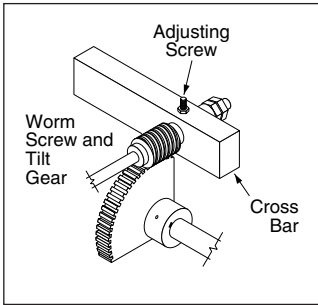

### TRUNNION HOUSING, WORM SCREW AND TILT GEAR

These parts are accessed through the top cover of the console.

Apply grease to gear teeth. Check for excessive play and adjust with adjusting screw located on top of cross bar.

### KETTLE TRUNNIONS

On the left hand side of the kettle there are two grease nipples on the top back portion of the trunnion housing. On the right hand side of the kettle you must remove the console cover to access the two grease nipples.

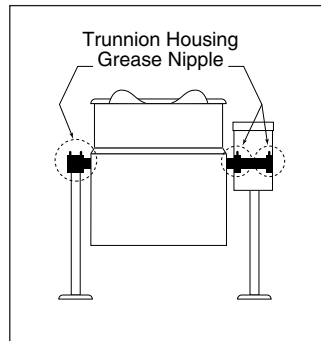

## HINGE ADJUSTMENT INSTRUCTIONS

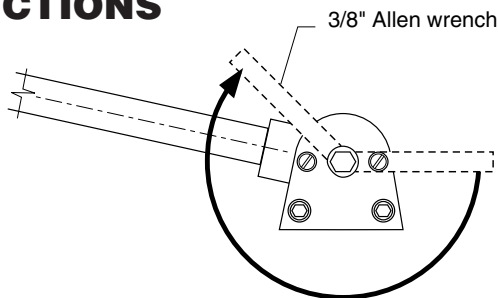

1. Insert 3/8" Allen wrench.
2. Turn clockwise to relieve tension on spring.
3. While tension is released remove one of the two slotted screws.
4. To prevent Allen wrench from springing back abruptly while the second slotted screw is removed, insert a pin (approximately 1/8") in the hole where the first slotted screw was removed from.
5. Remove second slotted screw.
6. While holding Allen wrench remove pin.
7. Turn Allen wrench clockwise to tighten or counter-clockwise to loosen tension to produce desired effect.
8. Re-insert pin in one of the two holes.
9. Tighten one slotted screw in the other hole (it may be necessary to turn Allen wrench slightly to align holes).
10. Remove pin and repeat step number 9 for other slotted screw.

## SSK SOLID STATE CONTROL TEST INSTRUCTIONS

**SSK Solid State Control** (part number KE00458-1)

<b>SWITCH</b>	○	<b>SWITCH</b> - Push for 5 seconds to enter TEST #1 Press again for TEST #2 and again for TEST #3
<b>CPU</b>	○	<b>CPU</b> - Rapid flashing during normal operation TEST #1 = 1 flash/sec Water level test TEST #2 = 2 flash/sec Thermistor test TEST #3 = 3 flash/sec Heater Output test
<b>DIAGNOSTIC LED</b>	○	<b>TEST #1</b> GREEN Probe senses water RED No water sensed
		<b>TEST #2</b> GREEN Thermistor is sensed ORANGE Thermistor is shorted RED Thermistor is open circuit
<b>POTENTIOMETER</b>	○	<b>LOW WATER</b>
		<b>HEATER OUTPUT</b>
		TEST #3 GREEN voltage output to relay for 20 seconds. Normal operation LED matches Front heater (green) LED

**THIS CONTROL BOX MUST BE CALIBRATED WHEN REPLACED**  
(see back for test and calibration instructions)

1. If required remove board from holding bracket for better access.
2. Turn unit on and set to 10 (maximum).
3. Push and hold the SWITCH button for approximately 5 seconds until the CPU starts to flash 1 flash/second. You are now in TEST #1. Output to 12v relay is disabled. With kettle upright the DIAGNOSTIC LED should be green, with kettle tilted it should be red.
4. Push SWITCH button. The CPU starts to flash 2 flash/second. You are now in TEST #2. Check the DIAGNOSTIC LED for indication of the temperature probe status.
5. Push SWITCH button. The CPU starts to flash 3 flash/second. You are now in TEST #3. The HEATER OUTPUT LED should light for 20 seconds and power to the relay should energize the 12v relay for the heat source.

After 20 seconds test mode is exited and unit reverts to normal operation.

## RESERVOIR FILL PROCEDURES

The kettle's water level must be maintained at the proper level to submerge the heater elements. Under normal operating conditions, the sealed water reservoir should never require the addition of water.

If the red "low water" light comes on during use (while the kettle is in an upright position), the water level has reached a critically low level. The low water protection control has automatically shut off the heater elements. The following procedure must be completed before further use:

**NOTE:** Have a qualified service technician repair the leakage problem and add water to the unit. Ensure that the red "low water" light is on when the kettle is upright. On tilting kettles, it is normal for the red light to come on when the kettle is in a tilted position, as the elements are not submerged in water at this point.

**CAUTION:** Only a mixture of distilled water and rust inhibitor should be used when adding water to a partially filled water reservoir. Local tap water conditions may cause kettle damage which is not covered under warranty. Rust inhibitor is purchased locally. Read directions and do not exceed manufacturer's recommendation (excessive rust inhibitor can also cause solidification).

## SPRING WATER REQUIREMENTS

Kettle Capacity	When Red "Low Water Light" comes on, add Distilled Water	When the Reservoir is Completely Empty, Add Distilled Water
<b>3 gallon</b>	50 ounces	120 ounces
<b>6 gallon</b>	70 ounces	160 ounces
<b>12 gallon</b>	120 ounces	2 gallon
<b>20 gallon</b>	1 gallon	3 gallon
<b>25 gallon</b>	1.0 gallon	3.8 gallon
<b>30 gallon</b>	1.5 gallon	4.3 gallon
<b>40 gallon</b>	2.0 gallon	4.8 gallon
<b>60 gallon</b>	2.1 gallon	5.8 gallon
<b>80 gallon</b>	2.6 gallon	6.5 gallon
<b>100 gallon</b>	2.8 gallon	7.3 gallon

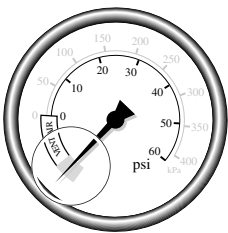

1. Ensure kettle is at room temperature and pressure gauge showing zero or less pressure.
2. Shut off power to the kettle at the fused disconnect switch.

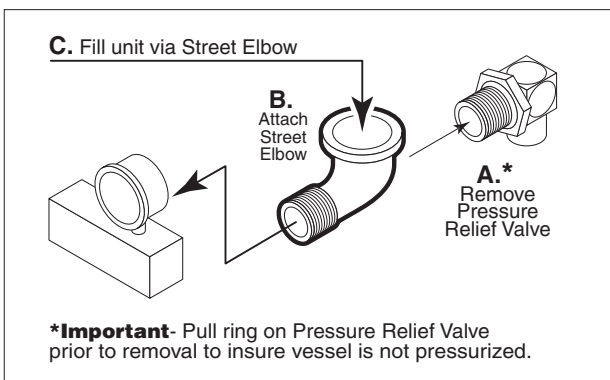

3. Pull Pressure Relief Valve (**A**) open to insure vessel is not pressurized.
4. Remove Pressure Relief Valve (**A**).
5. Replace Pressure Relief Valve (**A**) with Street Elbow (**B**).
6. Add Spring Water (**C**) through the Street Elbow (**B**), using a funnel if necessary. Refer to SPRING WATER REQUIREMENTS chart for the proper amount required.
7. Apply a thread sealant (i.e. Teflon tape) to the Pressure Relief Valve's (**A**) thread and replace.
8. Restore power to unit at the fused disconnect switch.
9. The kettle must now be vented. (Refer to the KETTLE VENTING INSTRUCTIONS).

## DRAINING PROCEDURE



**WARNING:** THE FUSED DISCONNECT SWITCH MUST BE OFF BEFORE REMOVING THE KETTLES BOTTOM COVER.

### Draining procedure

1. Pull pressure relief valve to insure there is no pressure within the kettle jacket.
2. Remove bottom covers.
3. Remove low water level probe and allow water to drain.
4. To rinse kettle jacket:
  - a) On tilting kettles fill jacket from low water probe fitting.
  - b) On stationary kettles:
    1. Replace low water probe.
    2. Remove pressure relief valve and replace with street elbow.
    3. Using a small funnel (one made of paper works great) slowly pour water into the kettle.
5. Allow kettle to drain again.
6. Repeat until water drains clear.

## REFILLING UNIT

1. Apply a thread sealant (i.e. Teflon tape) to the water level probe threads and replace.
2. See RESERVOIR FILL PROCEDURE

# WIRING DIAGRAM

200-240v

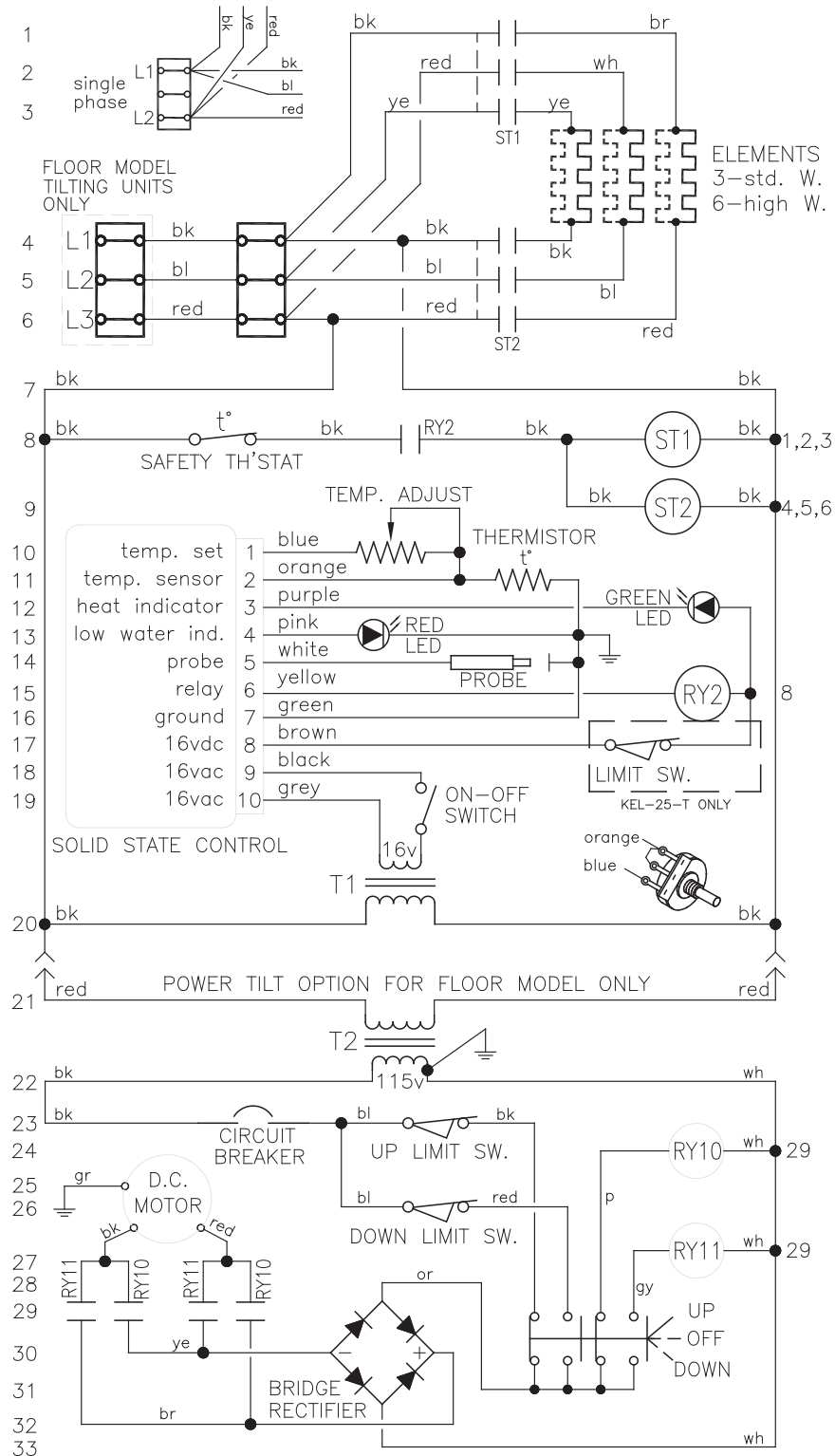

KEL, KEL-T & KET-6/12/20-T 208-240 VOLT KE90347-4 I

# WIRING DIAGRAM

480-600v

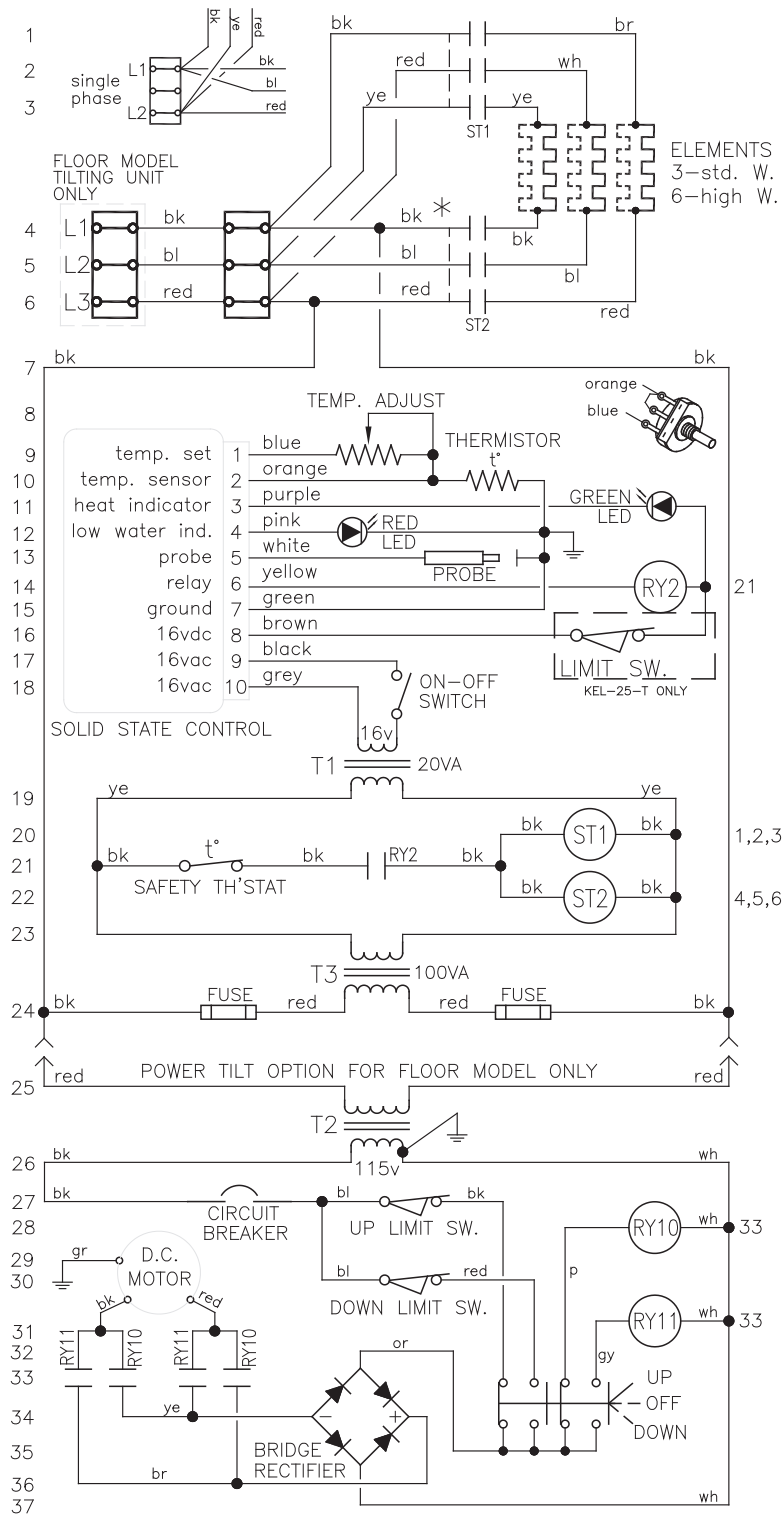

ELECTRIC KETTLE (EXCEPT KET-3-T) 480-600 VOLTS

KE90347-6 I

# SERVICE PARTS

## WARRANTY

Our Company supports a worldwide network of Maintenance and Repair Centers. Contact your nearest Maintenance and Repair Centre for replacement parts, service, or information regarding the proper maintenance and repair of your cooking equipment

In order to preserve the various agency safety certification (UL, NSF, ASME/Ntl. Bd., etc.), only factory-supplied replacement parts should be used. The use of other than factory supplied replacement parts will void warranty.

## HINGE ASSEMBLY

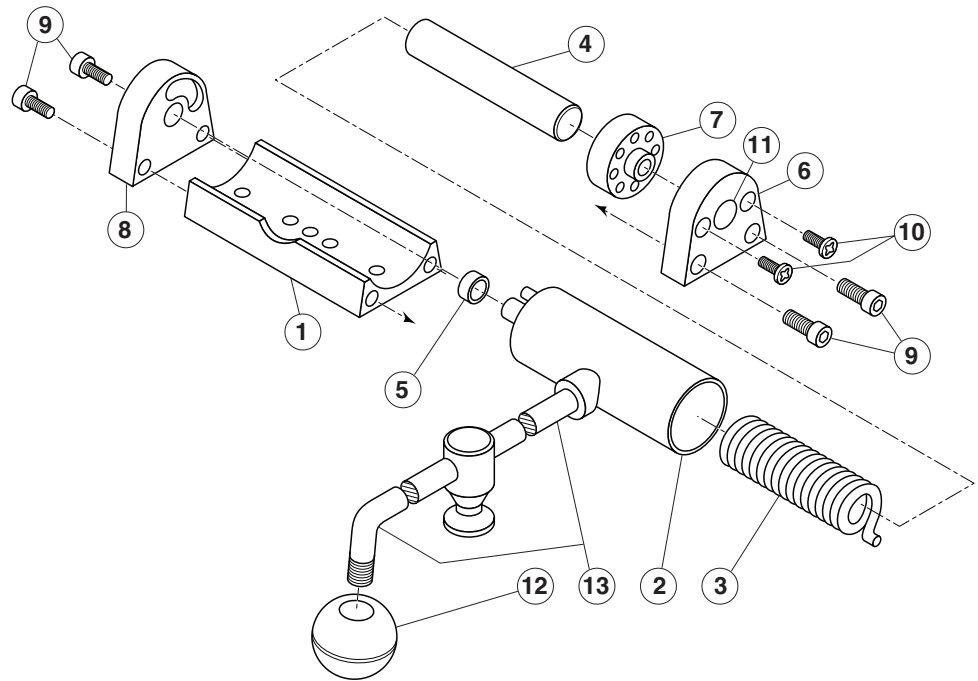

ITEM	PART #	DESCRIPTION	QTY	QTY	QTY	QTY
-	KE00597-6	HINGE ASSY; 25 GALLONS (100 DEG. OPENING, LIGHT SPRING)				▼
-	KE00597-4	HINGE ASSY; KGL-40TSH, HA-MKGL, KDM60T/CT (100 DEG. OPENING, HEAVY SPRING)				▼
-	KE00597-2	HINGE ASS'Y; 60-100 GALLONS, 30-60F (HEAVY SPRING)		▼		
-	KE00597-1	HINGE ASS'Y; 30-40 GALLONS, 20F, KDM25-40T/CT (LIGHT SPRING)	▼			
1	KE50822	HINGE BASE; CHS	1	1	1	1
2	KE51217	HINGE CYLINDER	1	1	1	1
3	KE50121-1	HINGE SPRING; HEAVY (0.187DIA/12 COILS)	-	1	1	-
	KE50121-2	HINGE SPRING; LIGHT (0.162DIA/16 COILS)	1	-	-	1
4	KE50823-1	HINGE PIN; LIGHT SPRING	1	-	-	1
	KE50823-2	HINGE PIN MODIFD; HEAVY SPRING	-	1	1	-
5	KE50824	HINGE BEARING; MODIFIED	1	1	1	1
6	KE50819-1	HINGE END PIECE; LHS	1	1	-	-
	KE50819-2	HINGE END PIECE; LHS MODIFIED (TO 100 DEGREE)	-	-	1	1
7	KE50820	HINGE INSERT; CHS	1	1	1	1
8	KE50819	HINGE END PIECE; RHS	1	1	1	1
9	FA11284	SCREW; 1/4-20 X 1/2" HEX SOCKET	4	4	4	4
10.	FA11507	Cutting Screw,	2	2	2	2
11.	KE54907-10	Plug Button	1	1	1	1
12.	KE50151-2	Knob	1	1	1	1
13.		Cover Handle (specify model)	1	1	1	1

# TRUNNION HOUSING - TILTING KETTLES

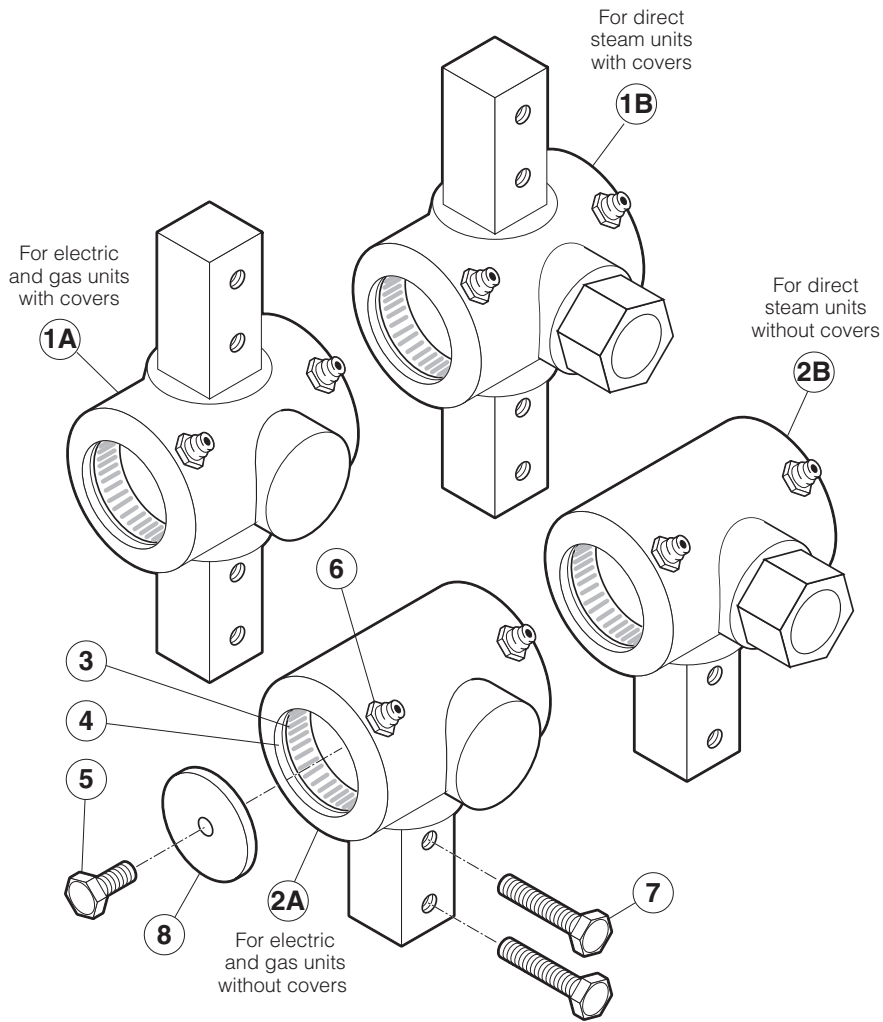

ITEM NO.	PART NO.	DESCRIPTION	QTY.
TRUNNION BEARING ASSEMBLIES (INCLUDES PART # 3, 4 & 6)			
1A.	KE00354	FOR ELECTRIC AND GAS UNITS WITH COVERS	.1
1B.	KE00353	FOR DIRECT STEAM UNITS WITH COVERS	.1
	KE003531	SERVICE HOUSING; SOLID BEARING (KDLT C/W COVER)	.1
2A.	KE00351	FOR ELECTRIC AND GAS UNITS WITHOUT COVERS	.1
2B.	KE00352	FOR DIRECT STEAM UNITS WITHOUT COVERS	.1
	KE003521	SERVICE HOUSING; SOLID BEARING (KDLT W/O COVER)	.1
3.	KE51711	ROLLER BEARING	.2
4.	KE51571-1	BEARING WASHER	.1
5.	FA95081-3	BOLT, 5/16-18 X 1/2"	.1
6.	KE51886	GREASE NIPPLE	.2
7.	FA11326	BOLT, 5/16-18 X 1 1/2"	.4/2
8.	KE50666	SPHERICAL WASHER	.1

# TANGENT DRAW-OFF VALVES

## 1.5" & 3" TANGENT DRAW-OFF VALVE

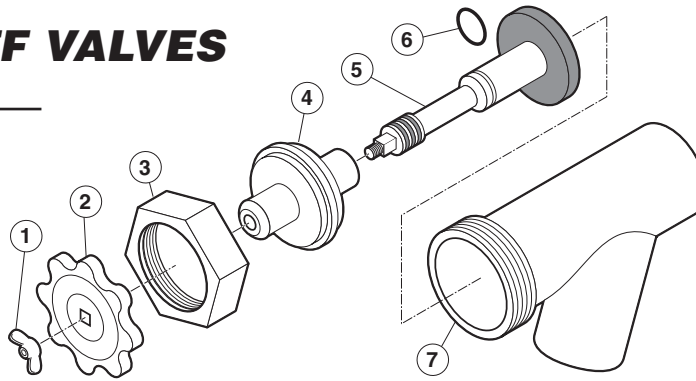

ITEM NO.	PART NO.	DESCRIPTION	QTY.
1. - 7.	KE50219	1.5" DRAW-OFF ASSEMBLY	1
	KE50973	3" DRAW-OFF ASSEMBLY	1
1.	SE50019	WING NUT, TD-1.5	1
	FA21501-1	ACCORN NUT, TD-3	1
	FA11511-1	SCREW (CORRECTIONAL PACKAGE)	1
	FA30505-1	WASHER (CORRECTIONAL PACKAGE)	1
2.	SE50017	KNOB, TD-1.5	1
	SE50018	KNOB, TD-3	1
3.	FI05180-3	HEX NUT, TD-1.5	1
	FI05180-2	HEX NUT, TD-3	1
4.	SE50011	RETAINER, TD-1.5	1
	SE50013	RETAINER, TD-3	1
5.	SE50008	PISTON, TD-1.5	1
	SE50010-1	PISTON, TD-3	1
	KE53290-4	PISTON, TD-3, MODIFIED (CORRECTIONAL PACKAGE)	1
6.	FA05002-24	"O" RING, TD-1.5	1
	FA05002-38	"O" RING, TD-3	1
7.	SE50005	VALVE BODY, TD-1.5	1
	KE50973	VALVE BODY, TD-3	1

## 2" TANGENT DRAW-OFF VALVE

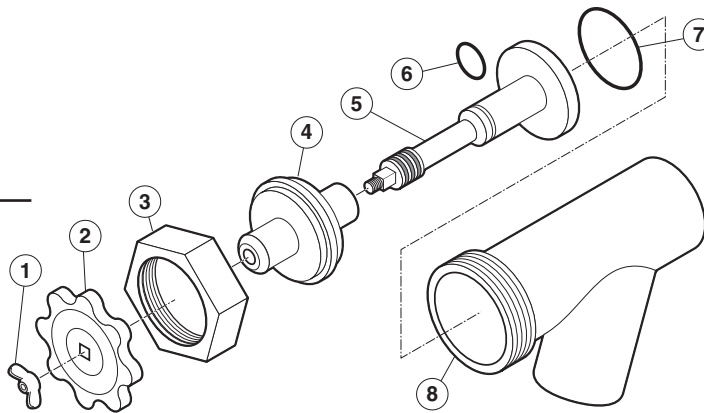

ITEM NO.	PART NO.	DESCRIPTION	QTY.
1. - 7.	KE50972-B	2" DRAW-OFF ASSEMBLY	1
1.	FA95049	WING NUT, TD-2	1
	FA511511-5	SCREW, TD-2 (CORRECTIONAL PACKAGE)	1
2.	KE52755	KNOB, TD-2	1
3.	FI05180-1	HEX NUT, TD-2	1
4.	KE52753	RETAINER, TD-2	1
5.	KE52752-1	PISTON, TD-2	1
	KE53290-3	PISTON, TD-2 (CORRECTIONAL PACKAGE)	1
6.	FA05002-24	"O" RING, BUNA-N (A-111), TD-2	1
7.	FA05002-55	"O" RING, VITON (AS568A-322), TD-2	1
8.	KE52751	VALVE BODY, TD-2	1

# KETTLE BOTTOM & SIDE

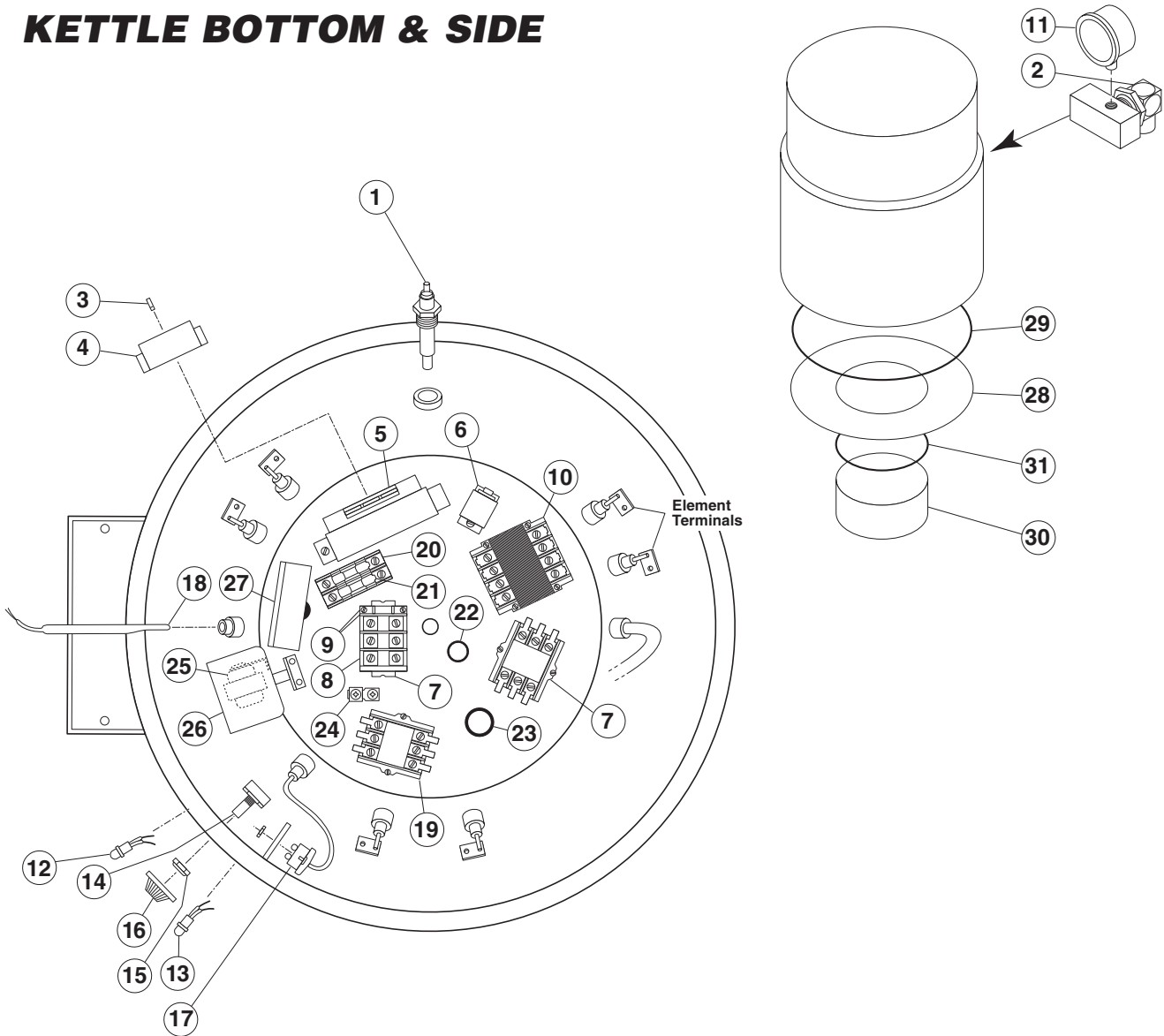

ITEM NO.	PART NO.	DESCRIPTION	QTY.
1.	KE50556-1	Probe, Water Level	1
2.	KE54941-5	Safety Valve, 50 PSI, 1/2" (North America)	1
	KE54941-31	Safety Valve, 50 PSI, 1/2", (Europe)	1
3.	KE51226	Wire Connector Terminal	10
4.	KE51225	Edge Connector	1
5.	KE00458	Solid State Control Box	1
6.	KE50753-7	Relay, 12 VDC	1
7.	KE54761	Bracket, Terminal Block	1
8.	KE50377	Terminal Block Section (Large, White)	3
	SK50055-1	Terminal Block Section (Small)	3
9.	KE50376	Terminal Block End Section (Large, White)	1
	SK50054-1	Terminal Block End Section (Small)	1
	SK50054-2	Terminal Block End Barrier	1
10.	KE53838-11	Transformer, 380-415 to 120-220V	1
	KE53838-12	Transformer, 440-480 to 240V	1
	KE53838-13	Transformer, 600 to 240V	1

11.	KE000714-4	Pressure Gauge, for units built prior to February 2005	1
	KE50429-5	Pressure Gauge, for units built after January 2005	1
12.	KE55486-1	L.E.D., Red, Replacement Kit., (includes LED & "O" Ring)	1
	KE55486-2	L.E.D., Green, Replacement Kit., (includes LED & "O" Ring)	1
	SE003013-3	L.E.D., Amber, Replacement Kit., (includes LED & "O" Ring)	1
14.	SE00115	Potentiometer with ON/OFF Switch, c/w Item #15	1
15.	KE51005	Rubber Boot	1
16.	KE50569-1	Knob, Potentiometer	1
17.	KE55069-5	Safety Thermostat (140° C)	1
18.	KE50515	Thermistor	1
19.	KE50750-3	Contactora, 208/240V, 40 Amp. (standard kettles)	2
	KE50750-4	Contactora, 208/240V, 50 Amp. (special high wattage kettles - 6 elements)	2
	KE50750-5	Contactora, 208/240V, 60 Amp. (special high wattage kettles - 6 elements)	2
20.	KE51139-1	Fuse Holder	1
21.	KE52936-1	Fuse, 1/2 amp (used on 380 to 600V units)	1
22.	KE54833-3	Snap-In Bushing, .875"	1
23.	KE54833-4	Snap-In Bushing 1.093"	1
24.	KE50473	Ground	1
25.	KE53838-21	Transformer, 240 to 16V	1
26.	KE00688	Transformer Enclosure (stationary kettles only)	1
27.	KE50392	Bracket, Electrical Entry, 1 3/4" hole (stationary kettles only)	1
<b>Bottom Cover - Stationary</b>			
28.	KE601174-1	KEL-25	1
	KE601174-2	KEL-30	1
	KE601174-3	KEL-40	1
	KE601174-4	KEL-60 / 40-SH	1
	KE601174-5	KEL-80 / 60-SH	1
	KE601174-6	KEL-100	1
<b>Bottom Cover - Tilting</b>			
	KE50999-1	KEL-25-T	1
	KE50999-2	KEL-40-T	1
	KE50999-3	KEL-60-T / 40-TSH	1
	KE50999-4	KEL-80-T / 60-TSH	1
	KE50999-5	KEL-100-T	1
<b>Bottom Cover Gasket - Stationary &amp; Tilting</b>			
29.	KE55425-5	25 Gallon	1
	KE55425-6	30 Gallon	1
	KE55425-7	40 Gallon	1
	KE55425-8	60 Gallon	1
	KE55425-9	80 Gallon	1
	KE55425-10	100 Gallon	1
<b>Component Enclosure - Stationary</b>			
30.	KE50389	all stationary models	1
<b>Component Enclosure - Tilting</b>			
	KE50471	all tilting models	1
<b>Component Enclosure Gasket - Stationary</b>			
31.	KE55425-16	all stationary models	1
<b>Component Enclosure Gasket - Tilting</b>			
	KE55425-11	all tilting models	1

# CONTROL CONSOLE COMPONENTS - HAND TILT

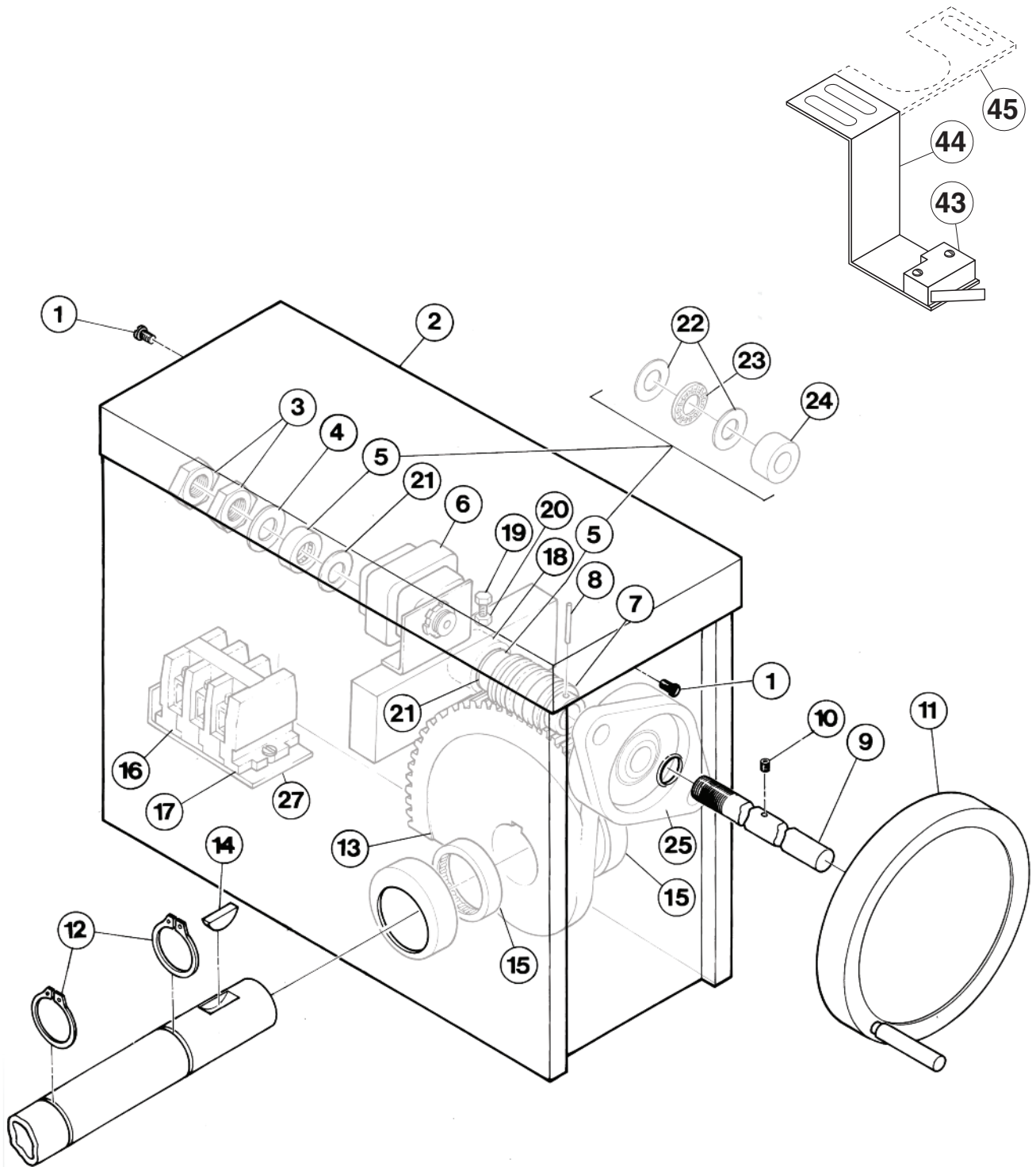

# **CONTROL CONSOLE COMPONENTS - HAND TILT**

<b>ITEM NO.</b>	<b>PART NO.</b>	<b>DESCRIPTION</b>	<b>QTY.</b>
1.	FA11134	Screw, 10-24 x 3/8" SS	2
2.	KE50325	Gear Box Lid	1
3.	FA95008	Locknut, 3/4-16	2
4.	FA30088	Washer, 1 1/2" O.D. x 13/16" I.D. x .125 "W.	1
5.	SE00036	Thrust Bearing Assembly and Spacer	2
6.	KE53838-21	Transformer, 240/16V	1
7.	KE50315	Worm	1
8.	FA95005	Tension Pin	1
9.	KE50375	Tilt Shaft	1
10.	FA19184	Set Screw, 3/8-16-3/8	1
11.	KE00508	Hand Wheel	1
12.	FA95007-1	Retaining Ring (25-40 gallon)	2
	FA95007-4	Retaining Ring (60 gallon & up)	2
13.	KE00151	Segment Gear (25-40 gallon)	1
	KE52833	Segment Gear (60 gallon & up)	1
14.	FA95055-12	Woodruff Key (25-40 gallon)	1
	FA95055-11	Woodruff Key (60 gallon & up)	1
15.	KE51711	Roller Bearing, trunnion (25-40 gallon)	2
	KE517111	Roller Bearing, trunnion (60 gallon & up)	2
16.	KE50377	Terminal Block Section (large, white)	3
	SK50055	Terminal Block Section (small, black)	3
17.	KE50376	Terminal Block End Section (large, white)	1
	SK50054	Terminal Block End Section (small, black)	1
18.	T40226	Bearing Assembly	1
19.	FA10623	Bolt, 5/16-24 x 1 1/2"	1
20.	FA20029	Hex Nut, 5/16-24	1
21.	KE51891	Washer, 1 1/2" O.D. x 13/16" I.D. x .037" W.	2
25.	KE51730	Bearing, tilt shaft	1
27.	KE50374	Bracket, Terminal Block Mounting	1
43.	SK2474500	Limit Switch	1
44.	KE602748	Bracket, 380 & 415 Volt (60 gallon and up)	1
45.	KE602754	Bracket, 380 & 415 Volt (25-40 gallon and up)	1



# CONTROL CONSOLE COMPONENTS - POWER TILT

ITEM NO.	PART NO.	DESCRIPTION	QTY.
1.	KE503252	Gear Box Lid . . . . .	1
2.	FA11134	Screw, 10-24 x 3/8" S.S. . . . .	1
3.	KE52832-1	Motor . . . . .	1
4.	KE53838-8	Transformer, 208/120V (HG3J) . . . . .	1
	KE53838-9	Transformer, 220, 240/120V (HG5J) . . . . .	1
5.	KE50583	Buna-N Insert . . . . .	1
6.	KE50582	Coupling . . . . .	2
7.	KE50377	Terminal Block Section (large, white) . . . . .	3
	SK50055	Terminal Block Section (small, black) . . . . .	3
8.	KE50376	Terminal Block End Section (large, white) . . . . .	1
	SK50054	Terminal Block End Section (small, black) . . . . .	1
9.	FA95008	Locknut, 3/4-16 . . . . .	2
10.	FA30088	Washer, 1 1/2" O.D. x 13/16" I.D. x .125" W. . . . .	1
11.	SE00036	Thrust Bearing Assembly and Spacer . . . . .	2
12.	FA95005	Tension Pin . . . . .	1
14.	KE003209-11	Complete Switch . . . . .	1
	KE603208-4	Momentary Switch Activator*** . . . . .	1
	KE603208-7	Contact Section Holder, Latch*** . . . . .	1
	KE603208-9	Contact Block*** . . . . .	4
***NOTE: for units built prior to Dec. 2006 order Complete Switch KE003209-11			
17.	KE50752	Transformer, 240/16V . . . . .	1
18.	FA95007	Retaining Ring (25-40 gallon) . . . . .	1
	FA95050	Retaining Ring (60 gallon & up) . . . . .	1
19.	FA95048	Woodruff Key (25-40 gallon) . . . . .	1
	FA95051	Woodruff Key (60 gallon & up) . . . . .	1
20.	KE50580	Water Resistant Boot . . . . .	1
22.	KE51007	Micro Switch . . . . .	2
23.	FA00012	"O" Ring, circuit breaker . . . . .	1
24.	KE00151	Segment Gear (25-40 gallon) . . . . .	1
	KE52833	Segment Gear (60 gallon & up) . . . . .	1
25.	KE50315	Worm . . . . .	1
26.	KE50441	Tilt Shaft . . . . .	1
27.	FA11092	Screw, 8-32 x 1/2", SS . . . . .	4
28.	KE51711	Roller Bearing, trunnion (25-40 gallon) . . . . .	2
	KE517111	Roller Bearing, trunnion (60 gallon & up) . . . . .	2
29.	KE51730	Bearing, tilt shaft . . . . .	1
30.	FA10623	Bolt, 5/16-24 x 1 1/2" . . . . .	1
31.	FA20028	Hex Nut, 5/16-24 . . . . .	1
32.	T40226	Bearing assembly . . . . .	1
33.	KE51891	Washer, 1 1/2" O.D. x 13/16" I.D. x .037" W. . . . .	2
37.	FA95037	Key, 3/16" x 3/16" x 3/4" . . . . .	1
39.	KE50579-1	Circuit breaker, 1.5 amp . . . . .	1
40.	KE50581	Bridge Rectifier . . . . .	1
41.	KE54535	Edge Connector (11 pin) . . . . .	2
42.	KE50753-10	Relay . . . . .	2
43.	SK24744500	Switch (CE option) . . . . .	1
44.	KE602748	Bracket, 380 & 415V (60 gallon and up) (CE option) . . . . .	1
45.	KE602754	Bracket, 380 & 415V (25-40 gallon and up) (CE option) . . . . .	1

# **SPARE PARTS LIST**

<b>ITEM ON.</b>	<b>DESCRIPTION</b>	<b>QTY. DOMESTIC</b>	<b>QTY. OVERSEAS</b>
-----------------	--------------------	--------------------------	--------------------------

## **Refer to Kettle Bottom & Side for parts drawing**

KE00458	Solid State Control Box	1	1
KE50753-7	Relay, 12 VDC		1
KE50750-5	Contactora, 208/240V, 60 Amp. (special high wattage kettles - 6 elements)	1	2
KE53838-11	Transformer, 380-415 to 120-220V		1
SE00115	Potentiometer with ON/OFF Switch, c/w Rubber Boot	1	1
KE51005	Rubber Boot	1	1
KE50569-1	Knob, Potentiometer	1	1
KE50515	Thermistor		1
KE51005	Rotary Seal		1
KE52936-1	Fuse, 1/2 amp (used on 380 to 600V units)		1
KE53838-19	Transformer, 120 to 16V	1	1
KE53838-21	Transformer, 240 to 16V	1	1

## **Refer to Faucet Assembly for drawing**

FA05002-19	"O" Ring for Faucet Spout	1	1
------------	---------------------------	---	---



Every new piece of Welbilt Foodservice equipment comes with KitchenCare® and you choose the level of service that meets your operational needs from one restaurant to multiple locations

**StarCare** – Warranty & lifetime service, certified OEM parts, global parts inventory, performance audited

**ExtraCare** — CareCode, 24/7 Support, online/mobile product information

**LifeCare** – Install & equipment orientation, planned maintenance, KitchenConnect™, MenuConnect®

**Talk with KitchenCare®** • 1-844-724-CARE • [www.mtwkitchencare.com](http://www.mtwkitchencare.com)



To learn how Welbilt Foodservice and its leading brands can equip you, visit our global web site at [www.welbilt.com](http://www.welbilt.com), then discover the regional or local resources available to you.