



Visit www.clevelandrange.com to locate a service or sales representative in your area.

Cleveland®

Direct Steam Vertical Mixer Kettles

Installation, Operation, and Maintenance Manual

This manual is updated as new information and models are released. Visit our website for the latest manual.

Model #s -

- (T) MKDL-40-T (-CC)
- (T) MKDL-60-T (-CC)
- (T) MKDL-80-T (-CC)
- (T) MKDL-100-T (-CC)
- (T) MKDL-125-T (-CC)
- (T) MKDL-150-T (-CC)

For your future reference.

Model # _____

Serial # _____



← Model # & Serial #.



Read the manual thoroughly.
Improper installation, operation or maintenance can cause property damage, injury or death.

Part # KE004015-2 REV C
October 2025

TABLE OF CONTENTS

STATEMENT OF RESPONSIBILITIES / DÉCLARATION DES RESPONSABILITÉS / DECLARACIÓN DE RESPONSABILIDADES	2
FOR YOUR SAFETY / POUR VOTRE SÉCURITÉ / PARA SU SEGURIDAD	4
INSTALLATION	8
GENERAL.....	8
RECEIVING INSPECTION.....	8
SHIPPING DAMAGE INSTRUCTIONS.....	8
UNCRATING	8
VENTILATION.....	8
COMPRESSED AIR CONNECTION.....	8
STEAM.....	8
CONDENSATE.....	8
POSITIONING	9
MOVING UNIT.....	9
LEVELING	9
PIPING SCHEMATIC.....	10
STEAM REQUIREMENTS FOR KETTLES	10
STEAM PIPE SIZING.....	10
ELECTRICAL.....	11
FOR POWER TILT UNITS ONLY	11
CLEANING	11
INSTALLATION CHECKS.....	11
OPERATING INSTRUCTIONS.....	12
OPERATING CONTROLS AND INDICATORS.....	12
OPERATING THE KETTLE.....	13
CLEANING INSTRUCTIONS	17
PREVENTATIVE MAINTENANCE	18
DAILY PRE-STARTUP INSPECTION.....	18
SIX MONTH SERVICE INSPECTION	18
YEARLY SERVICE INSPECTION.....	18
TROUBLESHOOTING AND MAINTENANCE PROCEDURES	19
MECHANICAL CHECKS.....	19
PRESSURE RELIEF VALVE TESTING PROCEDURE	19
STEAM TRAP.....	19
SAFETY VALVE INSTALLATION:.....	19
LUBRICATION.....	20
HYDRAULIC OIL REPLACEMENT PROCEDURE.....	20
RE-INSTALLING SPEED CONTROL CABLE	20
AIR LINE LUBRICATOR OIL FILLING PROCEDURE.....	20

STATEMENT OF RESPONSIBILITIES / DÉCLARATION DES RESPONSABILITÉS / DECLARACIÓN DE RESPONSABILIDADES

This document is for use by experienced and trained Qualified Cleveland Range, LLC Authorized Service Representatives who are familiar with both the safety procedures, and equipment they service. Cleveland Range, LLC assumes no liability for any death, injury, equipment damage, or property damage resulting from use of, improper use of, or failure to use the information contained in this document. Cleveland Range, LLC has made every effort to provide accurate information in this document, but cannot guarantee that this document does not contain unintentional errors and omissions.

The information in this document may be subject to technical and technological changes, revisions, or updates. Cleveland Range, LLC assumes no liability or responsibility regarding errata, changes, revisions, or updates.

Qualified Cleveland Range, LLC Authorized Service Representatives are obligated to follow industry standard safety procedures, including, but not limited to, OSHA regulations, and disconnect / lock out / tag out procedures for all utilities including steam, and disconnect / lock out / tag out procedures for gas, electric, and steam powered equipment and / or appliances.

All utilities (gas, electric, water and steam) should be turned OFF to the equipment and locked out of operation according to OSHA approved practices during any servicing of Cleveland Range equipment

Qualified Cleveland Range, LLC Authorized Service Representatives are obligated to maintain up-to-date knowledge, skills, materials and equipment.

Ce document est destiné à l'usage des Représentants de Service qualifiés et autorisés de Cleveland Range, LLC qui possèdent l'expérience et la formation ainsi que la bonne connaissance des mesures de sécurité et du matériel qu'ils entretiennent.

Cleveland Range, LLC décline toute responsabilité pour tout cas de décès, blessure, dommage matériel ou dommage aux biens résultant de l'utilisation, de la mauvaise utilisation ou du manquement d'utilisation des renseignements contenus dans ce document.

Cleveland Range, LLC s'est efforcé à fournir des renseignements précis dans ce document mais ne peut garantir que ce document soit exempt d'erreurs et d'omissions non intentionnelles.

Les renseignements contenus dans ce document peuvent être assujettis à des changements techniques et technologiques, des révisions ou des mises à jour.

Cleveland Range, LLC décline toute obligation ou responsabilité concernant les errata, modifications, révisions ou mises à jour.

Les Représentants de Service qualifiés et autorisés de Cleveland Range, LLC sont tenus de se conformer aux mesures de sécurité normalisées de l'industrie, y compris, mais sans s'y limiter, les réglementations de l'OSHA, les procédures de débranchement / verrouillage / étiquetage relatives à tous les services publics, dont l'approvisionnement en vapeur, et les procédures de débranchement / verrouillage / étiquetage relatives aux équipements et/ou appareils fonctionnant au gaz, à l'électricité et à la vapeur.

Au cours de tout entretien d'un appareil Cleveland Range, tous les services publics (gaz, électricité, eau et vapeur) doivent être FERMÉS au niveau de l'appareil et le dispositif de fonctionnement doit être verrouillé suivant les pratiques approuvées de l'OSHA.

Les Représentants de Service qualifiés et autorisés de Cleveland Range, LLC sont tenus d'actualiser en permanence leurs connaissances, compétences, matériel et équipement.

Este documento está destinado para el uso de los Representantes de Servicio calificados y autorizados de Cleveland Range, LLC quienes cuentan con la experiencia y la capacitación así como el buen conocimiento de las medidas de seguridad y de los equipos que mantienen.

Cleveland Range, LLC, declina toda responsabilidad en caso de cualquier fallecimiento, lesiones, daños al equipo o daños a la propiedad resultantes de la utilización, del uso indebido o de la falta de utilización de la información provista en este documento.

Cleveland Range, LLC se ha esforzado en suministrar información precisa en este documento, pero no puede garantizar que este documento esté exento de errores y de omisiones no intencionales.

La información contenida en este documento podría estar sujeta a cambios técnicos o tecnológicos, revisiones o actualizaciones. Cleveland Range, LLC declina toda obligación o responsabilidad con respecto a erratas, modificaciones, revisiones o actualizaciones.

Los Representantes de Servicio calificados y autorizados de Cleveland Range, LLC tienen la obligación de seguir los procedimientos estándar de seguridad de la industria; los cuales incluyen pero no se limitan a los reglamentos de la OSHA (La Administración de la Seguridad y Salud Ocupacionales), los procedimientos de desconexión, cierre y etiquetado relativos a todos los servicios públicos incluyendo el suministro de vapor y los procedimientos de desconexión, cierre y etiquetado para los equipos y/o aparatos que funcionan a base de gas, electricidad o vapor.

Cuando se esté dando servicio o mantenimiento a un aparato de Cleveland Range, todos los servicios públicos (gas, electricidad, agua y vapor) deben estar APAGADOS para el equipo en cuestión y se debe seguir el procedimiento de cierre de operaciones de acuerdo con las prácticas aprobadas por la OSHA.

Los Representantes de Servicio calificados y autorizados de Cleveland Range, LLC tienen la obligación de actualizar constantemente sus conocimientos, destrezas, materiales y equipamiento.

WARRANTY DISCLAIMER

Our Kettles, Mixers, Skillets, and Steamers are designed for commercial kitchen environments. To ensure optimal performance, longevity, and safety, the following conditions must be maintained:

- **Humidity & Moisture:** The equipment is designed to operate within standard commercial kitchen humidity levels of **40% to 65%** relative humidity. Prolonged exposure to humidity levels exceeding **65%** may compromise electrical components, cause condensation-related issues, and reduce equipment lifespan. Proper ventilation is essential to maintaining safe conditions.
- **Steam, Condensate & Water Exposure:** While the equipment can withstand occasional water splashes and steam exposure, direct and prolonged contact with high-pressure steam or continuous water spray may cause damage and void the warranty. Effective ventilation is required to manage steam buildup.
- **Ambient Temperature:** The recommended operating temperature range is **13°C (55°F) to 39°C (102°F)**. Exposure to temperatures beyond this range may impact performance, lead to malfunctions, or pose safety risks.
- **Ventilation Requirements:** Proper ventilation must be maintained to prevent excessive heat and humidity buildup, which can lead to overheating, reduced efficiency, and premature wear. Gas-fired equipment must only be installed under a ventilation hood in a room with adequate makeup air. Always consult local regulations to ensure compliance with ventilation standards.
- **Water Quality:** Follow Cleveland Range's water quality guidelines to ensure optimal equipment performance. Softening hard water reduces deposits, and filtration removes corrosive elements. Regular descaling, as recommended, prevents scale buildup. Consult a water treatment specialist and follow local regulations for proper management.
- **Installation and Preventive Maintenance:** Follow Cleveland Range's installation and preventive maintenance guidelines to ensure proper functioning and longevity of the units. Regular upkeep prevents issues and ensures optimal performance. Failure to follow the schedule may lead to reduced efficiency and breakdowns.
- **Drainage System:** Failure to follow Cleveland Range specifications may result in damage. Do not place a drain beneath the unit, as excessive moisture can shorten the lifespan of electrical and gas components, leading to potential malfunctions or hazards.

Failure to adhere to these conditions may result in decreased efficiency, equipment damage, or safety hazards and may void the manufacturer's warranty.

FOR YOUR SAFETY / POUR VOTRE SÉCURITÉ / PARA SU SEGURIDAD

FOR YOUR SAFETY

Do not store or use gasoline or any other flammable liquids and vapours in the vicinity of this or any other appliance.

POUR VOTRE SÉCURITÉ

Ne pas entreposer ou utiliser d'essence ou d'autres liquides ou vapeurs inflammables à proximité de cet appareil ou de tout autre appareil.

PARA SU SEGURIDAD

No guarde ni use gasolina o cualesquiera otros líquidos o vapores inflamables en las cercanías de éste o cualquier otro aparato.

WARNING: Improper installation, operation, adjustment, alteration, service or maintenance can cause property damage, injury or death.

Read the installation and operating instructions thoroughly before installing, operating or servicing this equipment.

AVERTISSEMENT: Toute mauvaise pratique en matière d'installation, de fonctionnement, de réglage, de modification, d'entretien ou de maintenance peut causer des dommages matériels, des blessures ou la mort. Lisez la totalité des instructions d'installation et d'utilisation avant d'installer, d'utiliser ou d'entretenir cet équipement.

ADVERTENCIA: La indebida instalación, operación, ajuste, modificación, servicio o mantenimiento puede ocasionar daños a la propiedad, lesiones o muerte. Lea detenidamente las instrucciones de instalación y de operación antes de instalar, poner a funcionar o dar servicio a este equipo.

Do not spray aerosols in the vicinity of this appliance while it is in operation.

This appliance is not to be used by persons with reduced physical, sensory or mental capabilities, or lack of experience and knowledge, unless they have been given supervision or instruction concerning use of the appliance by a person responsible for their safety.

This appliance is not for use by children and they must be supervised not to play with it.

Retain this manual for your reference.

Ne pas pulvériser des aérosols dans le voisinage de cet appareil alors qu'il est en fonctionnement.

Cet appareil ne doit pas être utilisé par des personnes dont les capacités physiques, sensorielles ou mentales sont réduites, ou des personnes dénuées d'expérience ou de connaissance, sauf si elles ont pu bénéficier, par l'intermédiaire d'une personne responsable de leur sécurité, d'une surveillance ou d'instructions préalables concernant l'utilisation de l'appareil.

















Conservez ce manuel pour votre référence.







No pulverice aerosoles en las proximidades de este aparato mientras está en funcionamiento.

Este aparato no debe ser utilizado por personas con capacidades físicas, sensoriales o mentales reducidas, o que no tengan la experiencia y los conocimientos adecuados, a menos que estas personas hayan recibido supervisión e instrucciones en cuanto al uso del aparato por la persona responsable de la seguridad de ellas.

Guarde este manual para su referencia.

WARNING / AVERTISSEMENT / ADVERTENCIA

	<p>Inspect unit daily for proper operation. / Inspecter le bloc quotidiennement pour garantir le fonctionnement normal. / Inspeccione diariamente el funcionamiento correcto de la unidad.</p>		<p>Stand clear of product discharge path when discharging hot product. / Se tenir loin du chemin de purge des produits lors de la purge des produits chauds. / Manténgase alejado de la trayectoria de descarga del producto al descargar producto caliente..</p>
	<p>Heavy. / Lourd. / Pesado Team or mechanical lift. / Levage en équipe ou mécanique. / Levantamiento en equipo o mecánico.</p>		<p>Surfaces may be extremely hot! Use protective equipment. / Les surfaces peuvent être extrêmement chaudes ! Utiliser des équipements de protection. / Las superficies pueden estar muy calientes! Utilice equipo protector.</p>
	<p>Keep clear of pressure discharge. / Se tenir hors de portée de la purge des soupapes de surpression. / Manténgase alejado de la descarga de presión.</p>		<p>Keep hands away from moving parts and pinch points. / Tenir les mains à l'abri des pièces mobiles et des angles. / Mantenga las manos lejos de las piezas móviles y los puntos de presión.</p>
	<p>Hot product and surfaces. / Produit et surfaces chaudes. / Producto y superficies calientes. Do not touch. / Ne pas toucher. / No la toque.</p>		<p>Do not fill kettle above recommended level marked on outside of kettle. / Ne pas remplir le chaudron au-delà du niveau indiqué à l'extérieur. / No llene la marmita por encima del nivel recomendado marcado en la parte exterior de la marmita.</p>
	<p>Unit must be anchored as per manual. / Unité doit être ancrée selon les directives du manuel.</p>		<p>Opening the drain cock will lead to the outflow of the hot contents of the boiling pan. Wear protective equipment when discharging hot product. / L'ouverture du robinet de vidange entraînera l'écoulement du contenu chaud de la marmite. Porter des équipements de protection lors de la purge des produits chauds. / La apertura de la llave de drenaje provocará la salida del contenido caliente de la marmita. Utilice equipo protector al descargar producto caliente.</p>
	<p>Floor may become slippery from product spillage. / Déversement de produit peut causer de plancher à être glissant. / Derrame de producto puede causar piso a ser resbaladizo.</p>		<p>In case of emergency or breakdown, refer to "Emergency" in OPERATING THE KETTLE section. / En cas d'urgence ou de panne, reportez-vous à « Urgence » dans la section FONCTIONNEMENT DE LA BOUILLLOIRE. / En caso de emergencia o avería, consulte "Emergencia" en la sección FUNCIONAMIENTO DEL HERVIDOR.</p>
	<p>Do not lean on or place objects on kettle lip. / Ne pas adosser ou placer des objets contre le bord de chaudron. / No se apoye en la tapa de la marmita ni coloque objetos sobre ella.</p>		<p>Do not remove guards or operate without them. / Ne pas supprimer les gardes ou fonctionner sans eux. / No retire los guardias ni funcionar sin ellos.</p>
	<p>Do not climb, sit or stand on equipment. / Il ne faut pas monter, s'asseoir ni se tenir debout sur l'équipement. / No subirse, ni sentarse ni pararse sobre el equipo.</p>		<p>Have a qualified service technician maintain your equipment. / Demandez à un technicien en entretien et en réparation qualifié d'effectuer l'entretien de votre équipement. / Haga que un técnico de servicio calificado mantenga su equipo.</p>

	<p>Keep appliance and area free and clear of combustibles. / Gardez l'appareil et son entourage libre de tous combustibles. / Mantenga el aparato y el área libres de combustibles.</p>		<p>Do not attempt to operate this appliance during a power failure. / N'essayez pas de faire fonctionner cet appareil lors d'une panne de courant. / No intente poner en marcha este aparato durante un fallo de suministro eléctrico.</p>
	<p>Shut off power at main fuse disconnect prior to servicing. / Couper l'alimentation sur le principal fusible sectionneur avant l'entretien. / Apague la alimentación eléctrica en el fusible desconectador principal antes de darle servicio.</p>		<p>Ensure kettle is at room temperature and pressure gauge is showing zero or less prior to removing any fittings. / S'assurer que le chaudron se trouve dans une température ambiante et que le manomètre affiche zéro ou moins avant de déposer les raccords. / Asegúrese de que la marmita está a temperatura ambiente y el manómetro está mostrando cero o menos antes de quitar cualquier accesorio.</p>
POWER SUPPLY / SOURCE DE COURANT / FUENTE DE ALIMENTACIÓN			
	<p>Appliance must <u>not</u> be supplied through an external switching device that is regularly switched on and off. / L'appareil ne doit pas être alimenté par un interrupteur externe régulièrement allumé et éteint. / El aparato no debe ser alimentado a través de un dispositivo de conmutación externo que se encienda y apague periódicamente.</p>		
MAINTENANCE / ENTRETIEN / MANTENIMIENTO			
	<p>The pressure relief valve must be inspected every six months. / La soupape de décharge doit être inspectée à tous les six mois. / La válvula de descarga de presión debe ser inspeccionada cada seis meses.</p> <p>Have a qualified service technician inspect your unit yearly. / L'unité doit être inspectée annuellement par un technicien de service qualifié.</p>		
	<p>Greasing must be performed every six months, as outlined in the maintenance procedures, to prevent wear or damage. / La lubrification doit être effectuée tous les six mois, conformément aux procédures de maintenance, afin d'éviter l'usure ou les dommages. / La lubricación debe realizarse cada seis meses, según los procedimientos de mantenimiento, para evitar el desgaste o los daños.</p>		

NOTICE

FOR THE USER

Read the Operating instructions thoroughly before using this equipment.

FOR THE INSTALLER

Read the Installation instructions thoroughly before installing or servicing this equipment.

Improper installation, adjustment, alteration, service or maintenance can cause property damage, injury or death.

This appliance is not to be used by persons with reduced physical, sensory or mental capabilities, or lack of experience and knowledge, unless they have been given supervision or instruction concerning use of the appliance by a person responsible for their safety.

This appliance is not for use by children, and they must be supervised not to play with it.

Any repairs to the pressure vessel must be done by a certified pressure vessel repair shop and all repair methods and materials must be approved by the manufacturer.

MODEL NUMBER LEGEND:

1	2	3	-	4	-	5
----------	----------	----------	----------	----------	----------	----------

1 – Type of Equipment

MK = Mixer Kettle
TMK = Twin Mixer Kettle

2 – Type of Power

E = Electricity
G = Gas
D = Direct Steam

3 – Type of Mount

L = Legs or Frame
M = Modular (Cabinetized)
T = Table Top

4 – Designation of Capacity in Gallon

From 3 Gallon to 200 Gallon

5 – Tilting Options

Blank = Stationary
T = Tilting

INSTALLATION

GENERAL

Environment:

Operating Criteria	Acceptable Range
Ambient Air Temperature	15-40 degrees Celsius
Relative Humidity	0-80%
Altitude	0-3000 meters
Voltage	208-480, 3ph
Location	Inside building, under ventilation hood

Ensure electrical supplies match rating plate. Installation of the kettle must be accomplished by qualified installation personnel working to all applicable local and national codes. This equipment is built to comply with applicable standards for manufacturers. Included among those approval agencies are: UL, NSF, ASME/N.Bd., CSA, ETL, and others. Many local codes exist, and it is the responsibility of the owner/installer to comply with these codes. Observe all clearance requirements. Do not obstruct the flow of combustion and ventilation air.

RECEIVING INSPECTION

Before unpacking visually inspect the unit for evidence of damage during shipping. If damage is noticed, do not unpack the unit, follow shipping damage instructions.

SHIPPING DAMAGE INSTRUCTIONS

If shipping damage to the unit is discovered or suspected, observe the following guidelines in preparing a shipping damage claim.

1. Write down a description of the damage or the reason for suspecting damage as soon as it is discovered. This will help in filling out the claim forms later.
2. As soon as damage is discovered or suspected, notify the carrier that delivered the shipment.
3. Arrange for the carrier's representative to examine the damage.
4. Fill out all carrier claims forms and have the examining carrier sign and date each form.

APPROXIMATE WEIGHTS

Model #	Unit	Unit with shipping box	Model #	Unit	Unit with shipping box
MKDL40T	700 lbs.	770 lbs.	TMKDL40T	1,360 lbs.	1,430 lbs.
MKDL60T	740 lbs.	810 lbs.	TMKDL60T	1,610 lbs.	1,680 lbs.
MKDL80T	830 lbs.	900 lbs.	TMKDL80T	1,700 lbs.	1,770 lbs.
MKDL100T	910 lbs.	980 lbs.	TMKDL100T	1,800 lbs.	1,870 lbs.
MKDL125T	1,000 lbs.	1,070 lbs.	TMKDL125T	1,890 lbs.	1,960 lbs.
MKDL150T	1,100 lbs.	1,170 lbs.	TMKDL150T	1,990 lbs.	2,060 lbs.

UNCRATING

Caution:

Straps under tension and will snap when cut.

Carton may contain staples and skid contains nails.

Use proper safety equipment and precautions.

Unit is heavy use adequate help or lifting equipment as needed.



1. Carefully cut any straps from container.
2. Lift off carton.
3. Inspect for hidden damage. If found refer to "SHIPPING DAMAGE INSTRUCTIONS".
4. Cut strap holding unit.
5. Remove lag bolts from feet.
6. Remove manual from kettle pot. Write down the model# and serial# of the unit onto the front of this manual.
7. Lift kettle off skid and move kettle to its installation location.
8. Discard packaging material according to local and or state requirements.



VENTILATION

Operation of these units can produce significant levels of steam and condensate, it is recommended they be installed under a ventilation hood in a room which has provisions for adequate make up air. Further information can be obtained by referring to the U.S.A. National Fire Protection Associations NFPA96 regulations. These standards have also been adopted by the National Building Code in Canada.

COMPRESSED AIR CONNECTION

Mixer Kettles with an air activated discharge valve require a minimum of 90 PSI to operate correctly.

If the unit is also supplying air to a Metering Filling Station then a pressure of 100 PSI at a minimum volume of 25 CFM is required.

The air supplied to the mixer should be clean and dry. No oil should be added to the supply air. We recommend the compressed air system be equipped with a drier, filter, and automatic water dump on the air compressor receiver tank. If the distance between the tank and the unit is less than 100 feet then a minimum line size of 3/4" is required. A distance of 100 to 300 feet requires a minimum 1" line.

STEAM

All steam plumbing to and from the kettle and steam boiler should be thoroughly cleaned and inspected for dirt and debris before final connection to the kettle are made.

Check the rating plate for the maximum steam pressure that your kettle is rated for. If the steam supply pressure exceeds the rated pressure, a pressure reducing valve is required. The steam inlet is at the right side of the kettle, as seen from the front.

CONDENSATE

A steam condensate trap must be plumbed to a drain, using minimum 1/2" NPT plumbing. The condensate line is limited to a maximum rise of 10 feet in order for the steam pressure to adequately force the condensate through the plumbing. Any higher rise requires a pump.

If the steam boiler to which this kettle is installed has a condensate return (closed loop system), a 1/2" steam strainer, a 1/2" steam trap, and a 1/2" check valve must be installed on the output (condensate) side of the kettle.

POSITIONING

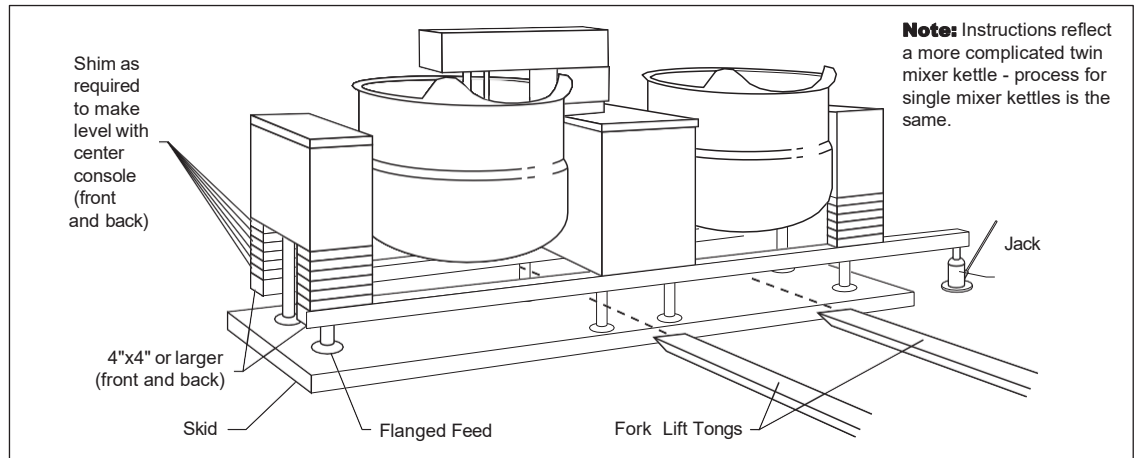

MOVING UNIT

1. While still on skid, move unit as close to final installation position as possible.
2. Prepare unit for lifting as shown in diagram.
3. Lift gently with a forklift or jacks and remove skid.
4. Lower gently to ground and remove forklift and blocking.
5. If unit has to be re-positioned, slide gently. Do not twist or push one side of unit excessively and cause binding on trunnions.

LEVELING

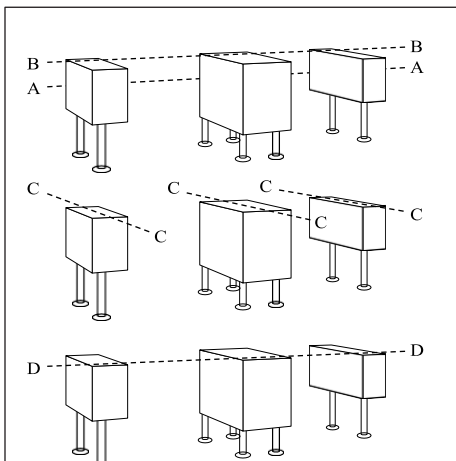

1. With straight-edge, line the backs of the consoles up with each other (dotted line **A**).
2. Level and straight-edge backs of consoles (dotted line **B**). Adjustments are made by turning flanges on back feet only.
3. Level consoles individually from front to back (dotted lines **C**). Adjustments are made by turning flanges on front feet only.
4. Re-check that the back is level (dotted line **B**) and then the front (dotted line **D**). Adjust if necessary.
5. Check that mixer bridge is level and guide pins (see illustration) lock smoothly without binding. If not repeat steps **1** through **4**.

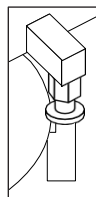

NOTE: See Operating Instructions before operating unit.

6. Make electrical connections (see electrical service connections) and test mixer bridge as follows:
 - A/** Raise mixer bridge: Move the bridge to its highest position.
 - B/** Swing bridge out over center console to far left and lower bridge.
 - C/** Bridge pins should enter pin hole on kettle perfectly. If not return to step 1 and repeat leveling steps.

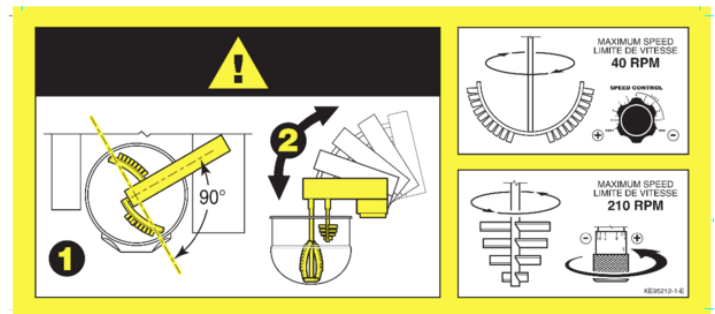

- D/** Raise bridge and swing to far right (for twin mixers only).
 - E/** Repeat steps **B** and **C** (for twin mixers only).
7. Once positioned and leveled, permanently secure the kettle's flanged feet to the floor using stainless steel lag bolts and floor anchors (supplied by the installer). Secure each of the flanged feet with one bolt in each hole. Seal joints of flanged feet with a silicone sealant.

ADDITIONAL TIPS:

- Verify that the hydraulic hoses are free from pinching and properly routed during movement of the arm.
- On twin mixer models, repeat all bridging and alignment checks for both sides.
- Ensure all electrical connections and safety systems are correctly installed before final operation.

PIPING SCHEMATIC

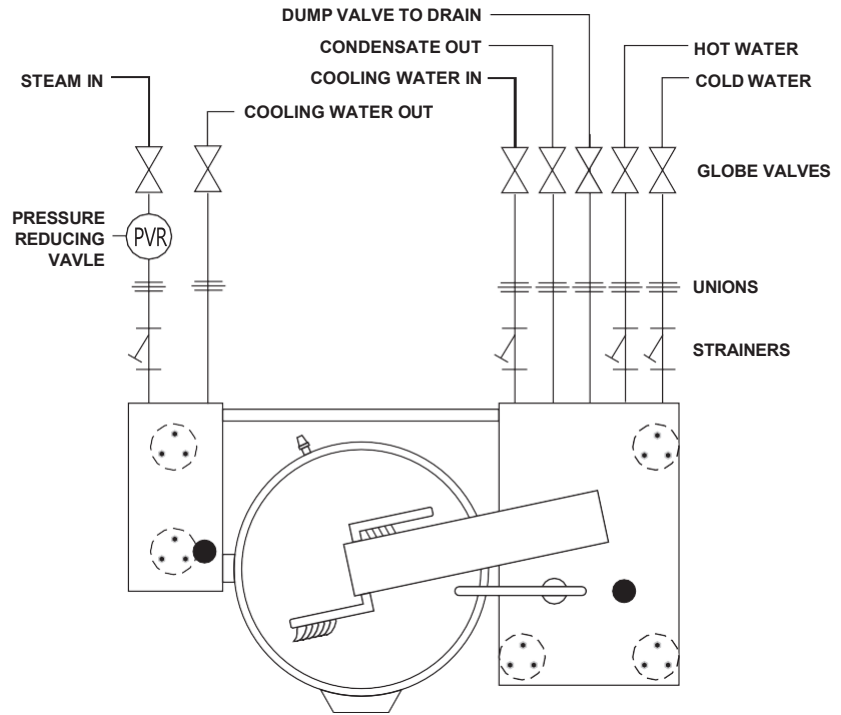

STEAM REQUIREMENTS FOR KETTLES

Kettle Cap. U.S. Gal.	Kettle Dia.	25 psi Steam 265°F		40 psi Steam 287°F		80 psi Steam 302°F	
		Lbs./Hr.	Hp./Hr.	Lbs./Hr.	Hp./Hr.	Lbs./Hr.	Hp./Hr.
40	26"	100	3	120	4	150	4.5
60	29.5"	150	4.5	190	5.5	230	7.0
80	33"	210	6.0	260	7.5	300	9.0
100	36"	260	7.5	320	9.5	390	11.0
125	40"	320	9.5	400	11.5	470	14.0
150	40"	390	11.0	480	14.0	570	17.0

- Steam requirements are maximum per hour.
- If more than one unit is on the same line then add the steam usage for each one to reach a total.

STEAM PIPE SIZING

Steam Required Lbs./Kg. per hour	Required pipe length in feet/meters		
	200 Ft.	400 Ft.	600 Ft.
	60 Meters	125 Meters	185 Meters
100/45 Kg.	3/4"	1"	1 1/4"
200/91 Kg.	1"	1 1/4"	1 1/2"
300/136 Kg.	1"	1 1/4"	1 1/2"
400/182 Kg.	1"	1 1/2"	1 3/4"
500/227 Kg.	1 1/4"	1 1/2"	1 3/4"
700/318 Kg.	1 1/2"	1 3/4"	2"
900/409 Kg.	1 1/2"	1 3/4"	2"

NOTES:

- Pipe size in inches.
- Less than 50 PSI (3.4 BAR) pressure, increase pipe size by 1/4".
- 80 to 100 PSI (5.5 to 6.8 BAR), Decrease pipe size by 1/4".

ELECTRICAL

ENSURE THE ELECTRICAL SUPPLY MATCHES THE KETTLE'S REQUIREMENTS AS STATED ON THE RATING LABEL.

Install in accordance with local codes and/or the National Electric Code ANSI/NFPA No 70-1981 (USA) or the Canadian Electric Code CSA Standard C22.1 (Canada). A separate fused disconnect switch must be supplied and installed. The kettle must be electrically grounded by the installer.

NOTE: This appliance is not GFI (GFCI) compatible.

The electric supply must match the power requirements specified on the kettle's rating plate. The copper wiring must be adequate to carry the required current at the rated voltage. Refer to the specification sheet for electrical specifications.

1. Ensure main power is turned off before connecting wires.
2. Remove the screws at the rear of the center console cover, and remove the cover. A wiring diagram is affixed to the underside of the console cover.
3. Feed permanent copper wiring 18" through the cut-out in the bottom of the console. Connect wiring in junction box in the bottom of the console.
4. Turn main power back on.
5. Check for correct rotation of electric motor (access by removing top front cover on center console). If rotation is incorrect, disconnect main power and reverse any two of the three live lines.
6. Replace the console cover and secure it with screws.

FOR POWER TILT UNITS ONLY

NOTE: Ensure the electrical supply matches the kettle's requirements as stated on the rating label.

This kettle is built to comply with CE standards. Many local codes exist, and it is the responsibility of the owner and installer to comply with these codes.

CLEANING

After installation the kettle must be thoroughly cleaned and sanitized prior to cooking.

INSTALLATION CHECKS

Although the kettle has been thoroughly tested before leaving the factory, the installer is responsible for ensuring the proper operation of kettle once installed.

1. Before turning the kettle on, read the vacuum/pressure gauge. The gauge's needle should be in the green zone. If the needle is in the "VENT AIR" zone, follow air venting procedure.
2. Before turning the kettle on, read the vacuum/pressure gauge. The gauge's needle should be in the green zone. If the needle is in the "VENT AIR" zone, follow air venting procedure.

3. Unit has been thoroughly checked for gas leaks at the factory however the installer should check all connections for any leaks which may have resulted from shipping or installation.
4. Supply power to the kettle by placing the fused disconnect switch to the "ON" position.
5. Open gas shut-off valve to turn on main gas supply.
6. Turn the temperature control knob to "1" (Min.). The green LED light should remain lit, indicating the burner is lit, until the set temperature is reached. Then the green light will cycle on and off, indicating the burner is cycling on and off to maintain temperature.
7. Tilt the kettle forward. After a few seconds the red "LOW WATER" light should be lit when the kettle is in a tilted position. This light indicates that the burner has automatically been shut off by the kettle's safety circuit. This is a normal condition when the kettle is in a tilted position.
8. Raise the kettle to the upright position. The red "LOW WATER" light should go out when the kettle is upright.
9. Turn the temperature control knob to "10" (Max.) and allow the kettle to preheat. The green light should remain on until the set temperature is reached. Then the green light will cycle ON and OFF, indicating the burner is cycling ON and OFF to maintain temperature.
10. Check carbon monoxide is less than 0.08 percent in an air-free sample of the flue gases. See FREE AIR CALCULATION procedure in "Maintenance Procedures & Parts Lists" manual.

MIXER

1. Raise Bridge - If bridge does not raise then check motor rotation. Bridge should not raise until speed control is turned to minimum and then adjusted back up.
2. Swing Bridge - Bridge when fully raised should swing without hitting any object, i.e. control housing, kettle lip. Check that hydraulic hoses are not being pinched by stops on swivel assembly.
3. Tilt Kettle - Kettle tilts smoothly both down and back up. If power tilt, check that micro switches are adjusted properly (kettle is level in upright position and drains fully when tilted) and are not being crushed by gear.
4. Lower Bridge - Raise bridge. Switch to mix. Turn speed control to zero to reset micro switch then set speed control to number four. Check that unit does not begin to mix until bridge has lowered part way into the kettle. Check that mixer bridge pin lowers into pin hole correctly.
5. Speed Control - Main - Main agitator arm not rotating when set at "0" but will start to move slowly on "1". Speed control makes positive contact with micro switch.
6. Speed Control - Secondary - Set main speed control to five. Adjust secondary control from minimum to maximum. Look for considerable speed variance.
7. Water Faucets - Turn on hot water faucet. Turn off and check for leaks in piping and drips from faucet spout. Repeat above with cold water faucet.
8. Product Discharge - Add water to kettle. Check for leaks from valve. Open and close valve a few times Valve and check for leaks again.

⚠ WARNING

If for any reason this unit is not functioning correctly DO NOT OPERATE. Contact your authorized service agent.

OPERATING INSTRUCTIONS



OPERATING CONTROLS AND INDICATORS

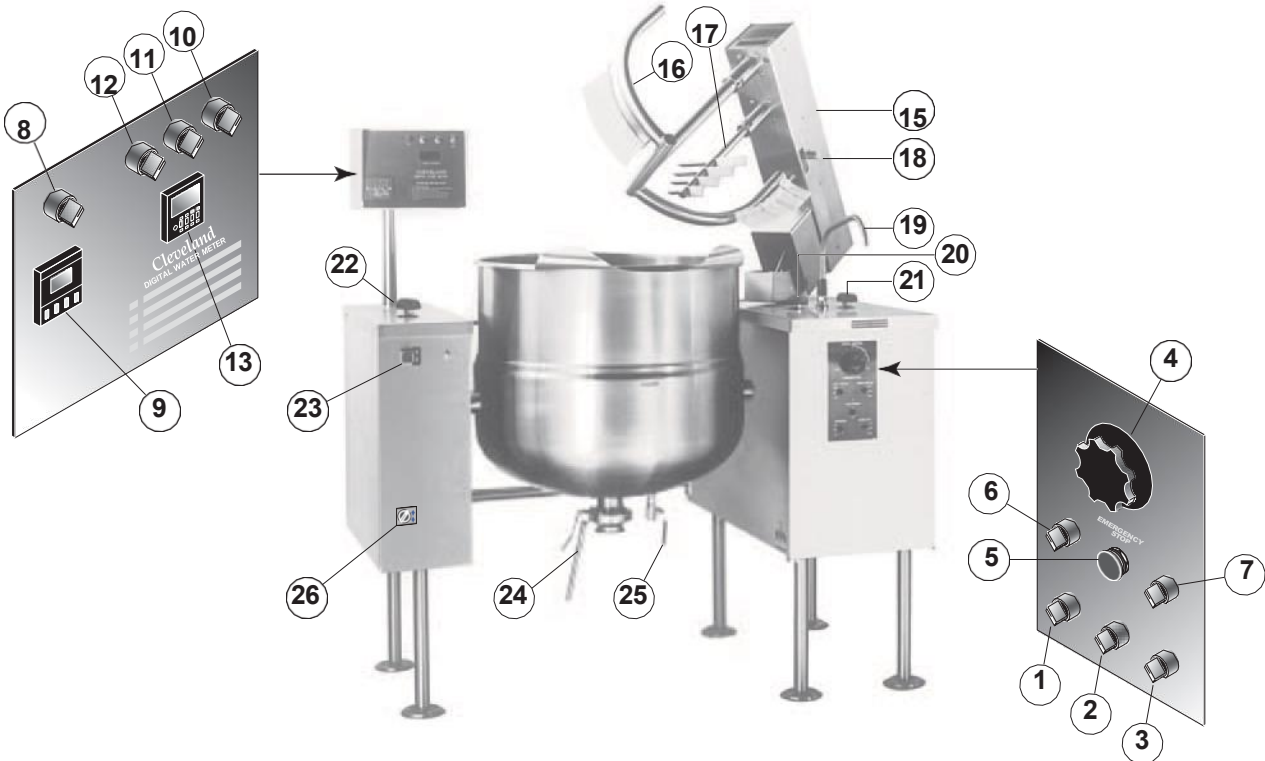

ITEM #	DESCRIPTION	FUNCTION
1	MAIN POWER SWITCH	Power switch for unit.
2	MIX/LIFT SWITCH	Sets hydraulics to mix or lift mode.
3	UP/DOWN SWITCH	When unit is in lift mode, mixer bridge can be raised or lowered with this switch.
4	MIXER SPEED CONTROL	Controls speed of agitators and mixer bridge lift.
5	EMERGENCY STOP BUTTON	Stops hydraulic system (agitators and mixer bridge lift).
6	HEAT/COOL SWITCH	Switches left hand kettle from heating to cooling.
7	HEAT/COOL SWITCH	Switches right hand kettle from heating to cooling.
8	ACTIVE/BYPASS SWITCH	Switch to activate or bypass (manual operation) the controller.
9	TEMPERATURE CONTROLLER	Digital temperature control and indicator.
10	WATER METER POWER SWITCH	Power switch for water meter.
11	WATER METER START SWITCH	Starts water flow to kettle.
12	WATER METER INTERRUPT SWITCH	Interrupts flow without resetting water meter.
13	WATER METER CONTROL	Display and settings for water meter.
15	MIXER BRIDGE	Encloses agitator motors.
16	MAIN AGITATOR ARM	Provides most of the product movement.
17	SECONDARY AGITATOR ARM	Provides reverse agitation and product lift in kettle.
18	SECONDARY SPEED CONTROL KNOB	Controls speed of secondary agitator arm.
19	FAUCET SPOUT	Delivers water to the kettle.
20	HOT WATER VALVE	Turns on hot water.
21	COLD WATER VALVE	Turns on cold water.
22	STEAM CONTROL VALVE	Manually controls the amount of steam entering the kettle.
23	POWER TILT CONTROL SWITCH	Used for tilting the kettle up or down. Replaced by hand tilt wheel on manual tilt units.
24	BUTTERFLY VALVE	Discharge valve for product in the kettle.
25	DRAIN COCK	Used to manually drain condensate from kettle.
26	AIR REGULATOR SWITCH	Used to open and close the air valve (optional/not shown).

OPERATING THE KETTLE



Intended Use:

Processing of food and pharmaceuticals in non-residential locations. Not for the making of dough or other heavy dough like products.

Intended Users:

- Supervised and trained staff during production periods.
- Trained maintenance and service personnel.

Removable component weights

Lbs (kg)	40 gal	60 gal	80 gal	100 gal	125 gal	150 gal
Main arm with blades	21 (9.5)	23 (10.4)	25 (11.3)	28 (12.7)	32 (14.5)	32 (14.5)
Baffle arm	7 (3.2)	7 (3.2)	8 (3.6)	10 (4.5)	12 (5.4)	12 (5.4)
Secondary arm	8 (3.6)	8 (3.6)	10 (4.5)	12 (5.4)	13 (5.9)	13 (5.9)
Screen	7 (3.2)	8 (3.6)	9 (4.1)	10 (4.5)	14 (6.4)	14 (6.4)
Air valve complete			12 (5.4)			
Air cylinder only			8 (3.6)			
Air valve body only			4 (1.8)			

Noise level

Noise level maximum 80 Decibels.

Mixing Arm Rotation speeds

Arm	Speed (RPM)
Primary	0-40
Secondary	0-210

Rim (loading) heights

Rim heights are given below. It is up to owners of the equipment to ensure the operators are performing the loading in a safe and acceptable manner.

Size	Height - BV3 valve	Height - PVA3 valve
40	40.5	40.75
60	43.75	44.25
80	44.75	46.26
100	44.5	48.75
125	44.5	48.75
150	48.5	53.5

Emergency

In the event of a fire or other emergency.

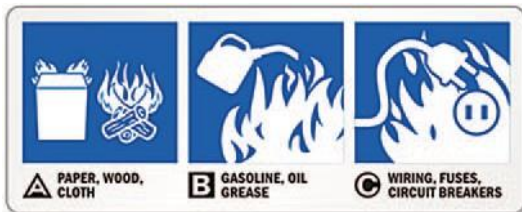

Turn off unit

Shut off power supplies including Electrical, Gas or Steam as applicable. (If safe to do so.)

Using fire extinguishers is only recommended if you are trained and feel safe to do so. Use only Fire extinguishers rated ABC.

This is a pressure vessel and with a properly operating safety valve will not exceed rated pressures. Jacket contains water and trace amounts of rust inhibitor and/or antifreeze.

WARNING:



This unit has been fitted with a warning buzzer for bridge movement and a cover and screen to prevent contact with moving mixer arms. Do not remove or bypass these safeties.

1. Perform daily startup inspection.
2. Preheat the kettle by turning the ON/OFF Temperature Control to the desired temperature setting. The Heat Indicator Light (Green) will remain lit, indicating the burner is on, until the temperature setting is reached. When the green light goes off, the burners are off, and preheating is complete.

NOTE: When cooking egg and milk products, the kettle should not be preheated, as products of this nature adhere to hot cooking surfaces.

3. Place food product into the kettle. The green Heat Indicator Light will cycle on and off indicating the burners are cycling on and off to maintain the set temperature.



4. When cooking is completed turn Temperature Control to the "OFF" position.
5. Pour the contents of the kettle into an appropriate container by tilting the kettle forward or using discharge valve.

NOTE: Cleaning should be completed immediately after cooked foods are removed.

NOTE: A five minute complete shut-of period is required before relighting.

Operating Suggestions

Cleveland Range Mixer Kettles are simple and safe to operate. The following tips will allow you to maximize the use of your new mixer.

If a mixer bridge is equipped with a temperature probe for a controller or thermometer, the probe must be submerged a minimum of three inches in the product for accurate readings.

Safety

As a safety precaution the MIXER SPEED CONTROL must first be turned to zero before unit will start to mix.

Always remember, like a cooking pot the kettles become very hot when cooking. Avoid contact with bare skin.

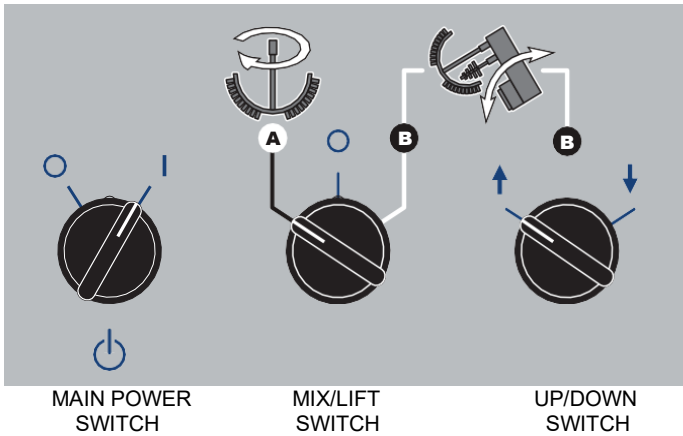

MAIN POWER SWITCH

MIX/LIFT SWITCH

UP/DOWN SWITCH

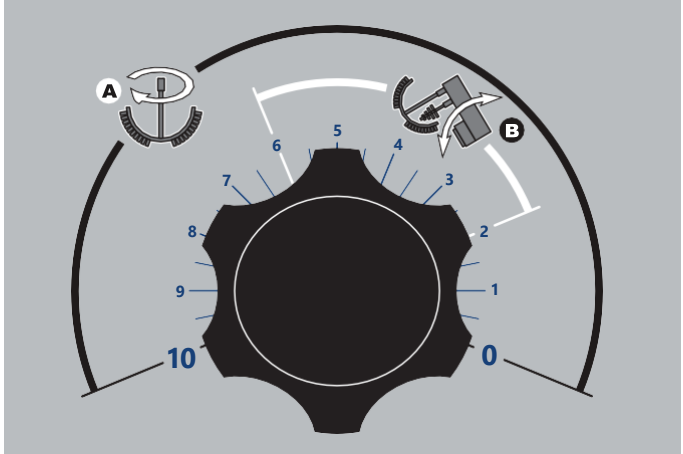

MIXER SPEED CONTROL SWITCH

General Operation

1. Turn MAIN POWER SWITCH on.
2. Turn Steam Control Valve to control heat kettle.

Lifting & Lowering Bridge

WARNING: Ensure FAUCET SPOUT is out of way before raising or lowering bridge.

1. Turn MIX/LIFT SWITCH to lift icon "B".
2. Turn MIXER SPEED CONTROL to "0" and back up to "5".
3. Turn and hold UP/DOWN SWITCH to up arrow to raise or down arrow to lower.

Mixing

1. Turn MIX/LIFT SWITCH to mix icon "A".
2. Turn MIXER SPEED CONTROL SWITCH to "0" and slowly adjust to desired speed.
3. Adjust SECONDARY SPEED CONTROL KNOB to desired speed.

Tilting Kettle

1. Raise MIXER BRIDGE and swing to side.
2. For manual tilt: Turn HANDWHEEL.
3. For power tilt: Turn POWER TILT CONTROL SWITCH.

WARNING: Do not tilt kettle when mixer agitators are in kettle bowl.

Product Discharge Valve

1. For butterfly valve: Push handle in and pull upwards to open.
2. For air valve: Turn Air Regulator Switch to open or close.



Turns on when unit is running

Actual Temperature

Set Temperature

Press arrow up/down to Set Temperature

Operation Using DTCI – JUMO LC100

Note: Temperature probe on mixer must be covered with a minimum of three inches of product to function correctly.



1. Turn mixer MAIN POWER switch to "ON" (JUMO LC100 lights up and displays present temperatures).



2. Turn HEAT/COOL switch to "OFF/AUTO".



3. Turn ACTIVE/BYPASS switch to "BYPASS". The unit should not be heating or cooling at this point.

4. To change set point temperature push ▲ or ▼ button.

5. Add product to kettle.



6. Turn ACTIVE/BYPASS switch to "ACTIVE". If the set point temperature is higher than the product temperature, the kettle will start heating.

Note:

- For twin kettles, JUMO LC100 will control the kettle the mixer is in.
- Button ⏪ is for programming mode only. Press ⏩ to exit programming mode.

DIGITAL WATER METER OPERATING INSTRUCTIONS

(USED AFTER APRIL 2019)

NOTE: The digital counter has been pre-set at the factory and should operate satisfactory. If installing a new counter (or the configuration settings to your existing digital counter become corrupted) you must configure the digital counter as shown below (**Configuring a Digital Counter**) prior to operation.

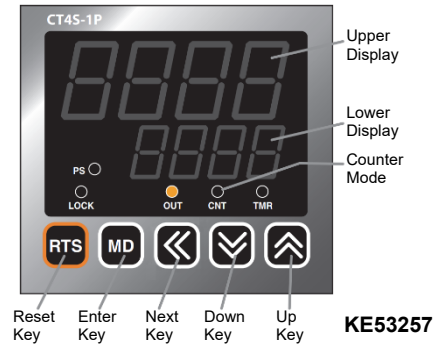

1. Turn POWER switch "ON".

2. Switch water to "Hot" or "Cold". (If option available).

3. To advance in setting value change mode, press key until the digit you want to change is flashing in the lower display window. Then use the or key to change the value of the flashing digit. When all digits are selected (lower display window) for the required quantity of water press the **MD** key to complete the change of setting value and return to run mode. The selection will not be registered in the memory if **MD** is not pressed.



4. Locate delivery spout over desired kettle.

RESET CONTINUE



5. Turn START switch to **RESET**. Delivery will start at 0 and stop at preset volume.

INTERRUPT



6. To stop delivery at any time, turn INTERRUPT switch to ●.

RESET CONTINUE



7. To complete delivery after interrupting, turn START switch to **CONTINUE**.



8. Push **RST** button to rest counter to 0 without starting delivery.

Hot Cold



9. Select Hot or Cold water if this option is available.

Configuring a Digital Counter

This procedure is only necessary when installing a replacement counter or settings to existing counter become corrupted.

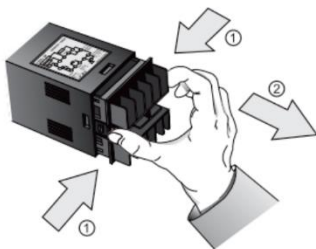

1. Power must be off.
2. Squeeze toward (1) and pull toward (2) as illustrated. (CTS/CTY Series)
3. Select input logic by using input logic switch (SW1) inside Counter/Timer.
4. Push case in opposite direction of (2).
5. Turn power on.

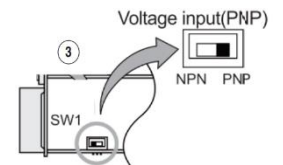

NOTE: Turn OFF the power before changing input logic. (PNP/NPN).



Editing Parameter Settings

After changing the switch position (see above instructions - **Configuring a Digital Counter**), edit the parameters as follows:

NOTE: The PS indicator light will turn off while the counter is in configuration mode.

1. Press and hold **MD** key for 3 seconds to enter parameter configuration mode. Use **MD** key to step through the parameters.
2. When the desired parameter description is shown in the upper display (see **Parameters Chart**), press  or  key to change the parameter.
3. When the desired setting is shown, press the **MD** key to move to the next parameter.
4. To exit configuration mode, press and hold **MD** key for 3 seconds.

Parameters Chart

Use **MD** key to step through Parameters



Parameter Description	Parameter Sign	Required Setting
Counter/Timer	[C-t]	CoUn
Input Mode	[In]	UP
Output Mode	[OUT.n]	C
Max. Counting Speed	[CPS]	30
Decimal Point	[dP]	----
Min. Reset Time	[rst]	20
Input Logic	[SIG]	PnP
Prescale Decimal Point	[SC.dP]	---.-
Prescale Value	[SCL]	001.0
Start Point Value	[StPt]	0000
Memory Protection	[dAtA]	CLr
Key Lock	[LoCK]	L.oFF

Use  or  key to step to the Required Setting



CLEANING INSTRUCTIONS



CARE AND CLEANING

Cooking equipment must be cleaned regularly to maintain its fast, efficient cooking performance and to ensure its continued safe, reliable operation. The best time to clean is shortly after each use (allow unit to cool to a safe temperature).

WARNINGS



Harsh Cleaners

Do not use harsh detergents or cleaners that are chloride-based, caustic, highly acidic, or contain quaternary salts.



Wire Brush & Scrapers

Do not use a metal bristle brush or scraper.



Steel Pads

Steel wool should never be used for cleaning the stainless steel.



High Pressure Spray Hose

Unit should never be cleaned with a high pressure spray hose.



Stagnant Water

Do not leave water sitting in unit when not in use.

CLEANING INSTRUCTIONS

1. Turn unit off.
2. Remove drain screen (if applicable). Thoroughly wash and rinse the screen either in a sink or a dishwasher.
3. Prepare a warm water and mild detergent solution in the unit.
4. Remove food soil using a nylon brush.
5. Loosen food which is stuck by allowing it to soak at a low temperature setting.
6. Drain unit.
7. Rinse interior thoroughly.
8. If the unit is equipped with a Tangent Draw-Off Valve, clean as follows:
 - a) Disassemble the draw-off valve first by turning the valve knob counter-clockwise, then turning the large hex nut counter-clockwise until the valve stem is free of the valve body.
 - b) In a sink, wash and rinse the inside of the valve body using a nylon brush.
 - c) Use a nylon brush to clean tangent draw-off tube.
 - d) Rinse with fresh water.
 - e) Reassemble the draw-off valve by reversing the procedure for disassembly. The valve's hex nut should be hand tight only.
9. If the unit is equipped with a Butterfly Valve, clean as follows:
 - a) Place valve in open position.
 - b) Wash using a warm water and mild detergent solution.
 - c) Remove food deposits using a nylon brush.
 - d) Rinse with fresh water.
 - e) Leave valve open when unit is not in use.
10. If the unit is equipped with an Air Valve, clean as follows:
 - a) Open product valve.
 - b) Disconnect air hoses.
 - c) Remove air cylinder.
 - d) Remove valve tee.
 - e) Remove all O-rings.
 - f) Clean air cylinder, do not submerge in water. Wipe clean and sanitize.
 - g) Clean and sanitize tee and O-rings.
 - h) Grease and reinstall O-rings.
 - i) Reinstall valve tee to kettle outlet.
 - j) Reinstall air cylinder to bottom of tee.
 - k) Reconnect air hoses.
 - l) Close valve and check for alignment.
11. Clean the scraper blades as follows:
 - a) Remove retaining ring and slide scraper blades off agitator arm.
 - b) Place parts in a pan of warm water to soak.
 - c) Clean in a sink, using a warm water and mild detergent solution.
 - d) Rinse with fresh water.
 - e) Allow to dry thoroughly on a flat, clean surface.

12. Using mild soapy water and a damp sponge, wash the exterior, rinse, and dry.

NOTES

- ⇒ For more difficult cleaning applications one of the following can be used: alcohol, baking soda, vinegar, or a solution of ammonia in water.
- ⇒ Leave the cover off when the kettle is not in use.
- ⇒ For more detailed instructions refer to Stainless Steel Equipment Care and Cleaning (www.nafem.org/resources/stainlessteelfinal.doc) on Nafem's website (www.nafem.org).



DISPOSAL INSTRUCTIONS

This unit is recyclable. Do not dispose in landfill.

The unit may contain rust inhibitor and or antifreeze within the jacket. Drain unit and dispose following Federal, State and local regulations.

The majority of the unit is composed of stainless steel. Other alloys and electrical components make up a small percentage of the total. Follow Federal, state and local regulations for disposal.



PREVENTATIVE MAINTENANCE

FOR MAINTENANCE AND REPAIRS CONTACT YOUR AUTHORIZED MANITOWOC SERVICE AGENCY AND HAVE A QUALIFIED SERVICE TECHNICIAN MAINTAIN YOUR EQUIPMENT.



WARNING:



If for any reason this unit is not functioning correctly DO NOT OPERATE. Contact your authorized service agent.



DAILY PRE-STARTUP INSPECTION

1. Product Discharge Valve and opens and closes.
2. Mixer Bridge lifts up and screen is in place.
3. All switches are functioning correctly.

SIX MONTH SERVICE INSPECTION

1. Perform daily startup inspection.
2. Gasket (G) around top cover is in good condition.
3. Tilt hand (H) wheel is tight.
4. **Grease bearings on both trunnions.**
5. Check for play in gears (adjust if required).
6. Fasteners securing panels are in place and tight.
7. **Perform pressure relief valve periodic test (see Pressure Relief Valve Testing).**
8. Adequate exhaust and makeup air is supplied to working area.
9. Check for hydraulic leaks.
10. Check safety systems have not been bypassed.

YEARLY SERVICE INSPECTION

1. Perform six month service inspection.
2. Replace hydraulic oil and filter.



TROUBLESHOOTING AND MAINTENANCE PROCEDURES



The following trouble shooting guide and maintenance procedures are meant to be used by Qualified Service Technician

ANY REPAIRS TO THE PRESSURE VESSEL MUST BE DONE BY A CERTIFIED PRESSURE VESSEL REPAIR SHOP AND ALL REPAIR METHODS AND MATERIALS MUST BE APPROVED BY THE MANUFACTURER.

For periodic maintenance recommendations see “Operators Manual”.

Extreme caution must be taken if unit is electrically energized for testing. Remove power from the unit while servicing. For periodic maintenance recommendations see “Operators Manual”.

MECHANICAL CHECKS

1. Inspect controls, replace damaged seals, switches, LED's etc.
2. Remove the console cover and check that the seal is not cracked or split. Replace seal, screws, missing or worn nylon anchor nuts. **Leave cover off.**
3. Remove the kettle bottom cover and check that the seal is not cracked or split. **Leave cover off.**

4. For units with tilt crank-

- A. Check that the kettle tilts smoothly. If there is excess play adjust the worm to gear clearance with Locking Nuts or Adjusting Screw as required.
- B. Check that there is no excessive wear in the trunnion bearings.
- C. Apply grease to gear teeth and bearings.

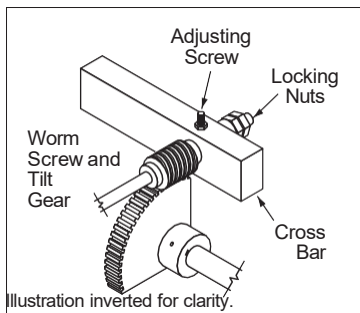

Grease Nipples.



PRESSURE RELIEF VALVE TESTING PROCEDURE

The pressure relief valve must be checked at least twice a year as part of the normal maintenance performed.

1. With the kettle empty, fully open the steam valve and allow the kettle to preheat.
 2. Stand to the side of the pressure relief valve discharge tube and pull valve open for maximum of one second. Repeat test three to four times. Each time the mechanism should move freely and be accompanied by a rapid escape of steam.
- ⇒ If valve appears to be sticking replace pressure relief valve.
 ⇒ If foreign material is discharged then drain kettle and replace pressure relief valve.

STEAM TRAP

To remove line condensate that forms inside the steam jacket, each kettle should be equipped with a steam trap in the line of the kettle outlet to the drain. A good steam trap at startup releases air and wet steam into the drain line for a few minutes, then holds the steam jacket. During cooking, the trap periodically releases accumulated condensate. If the kettle's cooking performance becomes inadequate after long use, replacement of the steam trap with a new one may restore kettle operation to peak efficiency.

SPARE PARTS LIST

PART NO.	DESCRIPTION	QTY.
KE51834	Scraper Blades.....	5
KE00860	Speed Control Cable Assembly	1
KE52936-6	Fuse, 3 Amp	2
KE50753-10	Relay	2-5
KE52936-16	Fuse	2
KE603208-9	Contact Block, Normally Open	2
KE603208-8	Contact Block, Normally Closed.....	2

SAFETY VALVE INSTALLATION:

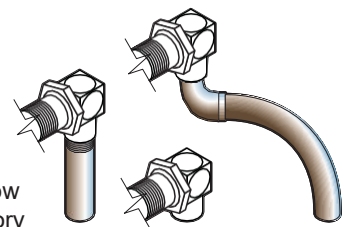

The above illustrations show the three variations of factory installed Safety Valves.

Modifications are unacceptable.

LUBRICATION

Lubricate the following parts every three months to ensure smooth operation and reduce wear.

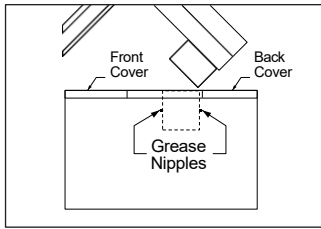

MIXER BRIDGE HOUSING

There are two grease nipples on the mixer bridge swivel housing which are accessed by removing the front and back covers on the 18" console.

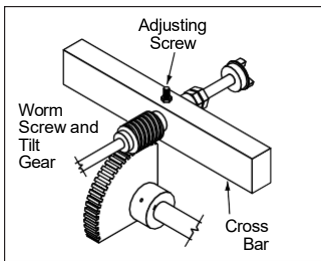

TRUNNION HOUSING, WORM SCREW AND TILT GEAR

These parts are accessed through the front cover on the 18" console.

Apply never seize to gear teeth. Check for excessive play and adjust with adjusting screw located on top of cross bar.

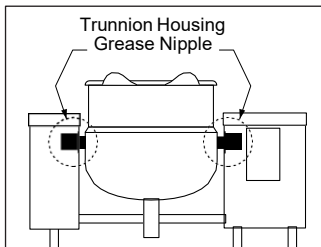

KETTLE TRUNNIONS

Accessed via the top covers on the 10" and 18" consoles. Each has two grease nipples.

HYDRAULIC OIL REPLACEMENT PROCEDURE

One of the most important maintenance tasks is to change the hydraulic oil yearly. Under heavy usage the oil should be changed every nine months. It is important to change the oil regularly to prevent its breakdown which leads to the damaging of components.

The oil filter should be changed at the same time as the hydraulic oil. A clean filter prevents particles from damaging the other components in the system.

Replace the hydraulic fluid as follows:

- ⇒ Disconnect power to unit.
- ⇒ Remove the front top panel on the main console.
- ⇒ Remove chrome vent cap from breather pipe located beside electric motor.
- ⇒ Remove plug bolt from bottom left front corner of main console to drain oil into your catch pail.
- ⇒ Remove oil filter.
- ⇒ Replace plug bolt.
- ⇒ Refill unit through breather pipe using approximately 12 U.S. gallons of Tellus 32 hydraulic oil (oil should be 6 1/2" deep in tank).
- ⇒ Install new oil filter (Part# SE50094).
- ⇒ Replace chrome vent cap and front top panel.
- ⇒ Reconnect power to unit.
- ⇒ Run unit to remove any air in the lines.

NOTE: Mixer may run rough and noisy for one or two hours if air has become trapped in the line.

RE-INSTALLING SPEED CONTROL CABLE

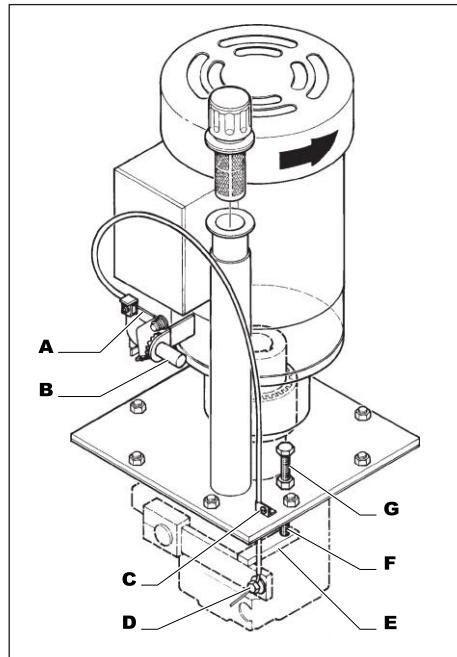

1. Turn sprocket of speed control so that wire "A" is fully extended towards shaft "B".
2. Insert end of cable through bracket "C".
3. Insert wire so it protrudes approximately 1/2" to 5/8" through hole in bolt "D". Tighten bolt and bend end of wire.
4. Bring pump arm "E" up until it hits stop bolt "F" and tighten screw "C".
5. Reassemble unit. Speed control knob will go on pointing toward minimum setting.
6. Turn mixer on with speed control set at minimum setting.
7. If scraper arm is turning, loosen nut "G" and back stop bolt "F" off a few turns. Next loosen screw "C" and slowly pull up cable until scraper arm stops turning. Retighten screw "C". Gently turn stop bolt "F" down until it hits arm. Lock in place by tightening nut "G".
8. Scraper arm should now go from no rotation to fast rotation by turning speed control knob.

NOTE: Mixer may run rough and noisy for one or two hours if air has become trapped in the line.

AIR LINE LUBRICATOR OIL FILLING PROCEDURE

1. Disconnect air supply and bleed system.
2. Remove cover on console
3. Check for oiler location.
4. Inspect oil level in bowl.
5. Remove filler cap.
6. Add mineral oil as required.
7. Replace filler cap and console cover.

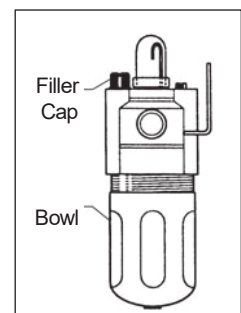

TROUBLESHOOTING GUIDE

This section contains information intended for use by Authorized Service Personnel only.

PROBLEM

A/ *Kettle heats too slowly or does not come to a boil.*

Probable Cause	Remedy
1. Inadequate steam flow.	Check for correct steam using chart below. If kettle is connected to a steamer and powered by a generator the units should be operated sequentially (kettle boiling first, then start steamer).
2. Steam trap not operating properly.	The trap should open periodically to dump condensate, then close. If it does not open or close it should be cleaned or replaced.
3. Food batches are not always the same.	When checking make certain that the original state (ie. fresh or frozen) and quantity of food product is the same.

PROBLEM

B/ *The trunnion housing leaks steam.*

Probable Cause	Remedy
1. Trunnion "O" rings are worn.	Replace "O" rings

PROBLEM

B/ *The steam trap makes a banging noise when steam applied to cold kettle.*

Probable Cause	Remedy
1. Kettle condensate has not been drained.	On all tilting models the condensate should be drained from the cold kettle. This is done before steam is applied using the drain cock valve on the bottom of the kettle.

STEAM REQUIREMENTS FOR KETTLES

Kettle Cap. U.S. Gal.	Kettle Dia.	25 psi Steam 265°F		40 psi Steam 287°F		80 psi Steam 302°F	
		<u>Lbs./Hr.</u>	<u>Hp./Hr.</u>	<u>Lbs./Hr.</u>	<u>Hp./Hr.</u>	<u>Lbs./Hr.</u>	<u>Hp./Hr.</u>
40	26"	100	3	120	4	150	4.5
60	29.5"	150	4.5	190	5.5	230	7.0
80	33"	210	6.0	260	7.5	300	9.0
100	36"	260	7.5	320	9.5	390	11.0
125	40"	320	9.5	400	11.5	470	14.0
150	40"	390	11.0	480	14.0	570	17.0

- Steam requirements are maximum per hour.
- If more than one unit is on the same line then add the steam usage for each one to reach a total.

Every new piece of Welbilt Foodservice equipment comes with KitchenCare® and you choose the level of service that meets your operational needs from one restaurant to multiple locations

StarCare – Warranty & life-time service, certified OEM parts, global parts inventory, performance audited

ExtraCare – CareCode, 24/7 Support, online/mobile product information

LifeCare – Install & equipment orientation, planned maintenance, KitchenConnect™, MenuConnect®

Talk with KitchenCare® • 1-844-724-CARE • www.mtwkitchencares.com



To learn how Welbilt Foodservice and its leading brands can equip you, visit our global web site at www.welbilt.com, then discover the regional or local resources available to you.