



Visit www.clevelandrange.com to locate a service or sales representative in your area.



Gas Table Top Kettles

Installation, Operation, Maintenance, Parts & Service

This manual is updated as new information and models are released. Visit our website for the latest manual.

MODELS:

- KGT6T
- KGT12T
- KGT12TGB



For your future reference.

Model # _____

Serial # _____

← Model # & Serial #.



**Read the manual thoroughly.
Improper installation, operation or
maintenance can cause property
damage, injury or death.**

TABLE OF CONTENTS

Statement of Responsibilities	1
For your Safety	2
Installation	4
Operating Instructions	7
Cleaning Instructions	8
Safety Inspection Checklist	9
Service Procedures	12
Service Parts	19



STATEMENT OF RESPONSIBILITIES / DÉCLARATION DES RESPONSABILITÉS / DECLARACIÓN DE RESPONSABILIDADES

This document is for use by experienced and trained Qualified Cleveland Range, LLC Authorized Service Representatives who are familiar with both the safety procedures, and equipment they service. Cleveland Range, LLC assumes no liability for any death, injury, equipment damage, or property damage resulting from use of, improper use of, or failure to use the information contained in this document. Cleveland Range, LLC has made every effort to provide accurate information in this document, but cannot guarantee that this document does not contain unintentional errors and omissions.

The information in this document may be subject to technical and technological changes, revisions, or updates. Cleveland Range, LLC assumes no liability or responsibility regarding errata, changes, revisions, or updates.

Qualified Cleveland Range, LLC Authorized Service Representatives are obligated to follow industry standard safety procedures, including, but not limited to, OSHA regulations, and disconnect / lock out / tag out procedures for all utilities including steam, and disconnect / lock out / tag out procedures for gas, electric, and steam powered equipment and / or appliances.

All utilities (gas, electric, water and steam) should be turned OFF to the equipment and locked out of operation according to OSHA approved practices during any servicing of Cleveland Range equipment

Qualified Cleveland Range, LLC Authorized Service Representatives are obligated to maintain up-to-date knowledge, skills, materials and equipment.

Ce document est destiné à l'usage des Représentants de Service qualifiés et autorisés de Cleveland Range, LLC qui possèdent l'expérience et la formation ainsi que la bonne connaissance des mesures de sécurité et du matériel qu'ils entretiennent.

Cleveland Range, LLC décline toute responsabilité pour tout cas de décès, blessure, dommage matériel ou dommage aux biens résultant de l'utilisation, de la mauvaise utilisation ou du manquement d'utilisation des renseignements contenus dans ce document.

Cleveland Range, LLC s'est efforcé à fournir des renseignements précis dans ce document mais ne peut garantir que ce document soit exempt d'erreurs et d'omissions non intentionnelles.

Les renseignements contenus dans ce document peuvent être assujettis à des changements techniques et technologiques, des révisions ou des mises à jour.

Cleveland Range, LLC décline toute obligation ou responsabilité concernant les errata, modifications, révisions ou mises à jour.

Les Représentants de Service qualifiés et autorisés de Cleveland Range, LLC sont tenus de se conformer aux mesures de sécurité normalisées de l'industrie, y compris, mais sans s'y limiter, les réglementations de l'OSHA, les procédures de débranchement / verrouillage / étiquetage relatives à tous les services publics, dont l'approvisionnement en vapeur, et les procédures de débranchement / verrouillage / étiquetage relatives aux équipements et/ou appareils fonctionnant au gaz, à l'électricité et à la vapeur.

Au cours de tout entretien d'un appareil Cleveland Range, tous les services publics (gaz, électricité, eau et vapeur) doivent être FERMÉS au niveau de l'appareil et le dispositif de fonctionnement doit être verrouillé suivant les pratiques approuvées de l'OSHA.

Les Représentants de Service qualifiés et autorisés de Cleveland Range, LLC sont tenus d'actualiser en permanence leurs connaissances, compétences, matériel et équipement.

Este documento está destinado para el uso de los Representantes de Servicio calificados y autorizados de Cleveland Range, LLC quienes cuentan con la experiencia y la capacitación así como el buen conocimiento de las medidas de seguridad y de los equipos que mantienen.

Cleveland Range, LLC, declina toda responsabilidad en caso de cualquier fallecimiento, lesiones, daños al equipo o daños a la propiedad resultantes de la utilización, del uso indebido o de la falta de utilización de la información provista en este documento.

Cleveland Range, LLC se ha esforzado en suministrar información precisa en este documento, pero no puede garantizar que este documento esté exento de errores y de omisiones no intencionales.

La información contenida en este documento podría estar sujeta a cambios técnicos o tecnológicos, revisiones o actualizaciones. Cleveland Range, LLC declina toda obligación o responsabilidad con respecto a erratas, modificaciones, revisiones o actualizaciones.

Los Representantes de Servicio calificados y autorizados de Cleveland Range, LLC tienen la obligación de seguir los procedimientos estándar de seguridad de la industria; los cuales incluyen pero no se limitan a los reglamentos de la OSHA (La Administración de la Seguridad y Salud Ocupacionales), los procedimientos de desconexión, cierre y etiquetado relativos a todos los servicios públicos incluyendo el suministro de vapor y los procedimientos de desconexión, cierre y etiquetado para los equipos y/o aparatos que funcionan a base de gas, electricidad o vapor.

Cuando se esté dando servicio o mantenimiento a un aparato de Cleveland Range, todos los servicios públicos (gas, electricidad, agua y vapor) deben estar APAGADOS para el equipo en cuestión y se debe seguir el procedimiento de cierre de operaciones de acuerdo con las prácticas aprobadas por la OSHA.

Los Representantes de Servicio calificados y autorizados de Cleveland Range, LLC tienen la obligación de actualizar constantemente sus conocimientos, destrezas, materiales y equipamiento.

FOR YOUR SAFETY / POUR VOTRE SÉCURITÉ / PARA SU SEGURIDAD

FOR YOUR SAFETY

Do not store or use gasoline or any other flammable liquids and vapours in the vicinity of this or any other appliance.

POUR VOTRE SÉCURITÉ

Ne pas entreposer ou utiliser d'essence ou d'autres liquides ou vapeurs inflammables à proximité de cet appareil ou de tout autre appareil.

PARA SU SEGURIDAD

No guarde ni use gasolina o cualesquiera otros líquidos o vapores inflamables en las cercanías de éste o cualquier otro aparato.

WARNING: Improper installation, operation, adjustment, alteration, service or maintenance can cause property damage, injury or death. Read the installation and operating instructions thoroughly before installing, operating or servicing this equipment.

AVERTISSEMENT : Toute mauvaise pratique en matière d'installation, de fonctionnement, de réglage, de modification, d'entretien ou de maintenance peut causer des dommages matériels, des blessures ou la mort. Lisez la totalité des instructions d'installation et d'utilisation avant d'installer, d'utiliser ou d'entretenir cet équipement.

ADVERTENCIA: La indebida instalación, operación, ajuste, modificación, servicio o mantenimiento puede ocasionar daños a la propiedad, lesiones o muerte. Lea detenidamente las instrucciones de instalación y de operación antes de instalar, poner a funcionar o dar servicio a este equipo.

Do not spray aerosols in the vicinity of this appliance while it is in operation.

This appliance is not to be used by persons with reduced physical, sensory or mental capabilities, or lack of experience and knowledge, unless they have been given supervision or instruction concerning use of the appliance by a person responsible for their safety.

This appliance is not for use by children and they must be supervised not to play with it.

Post in a prominent location, instructions to be followed in the event the user smells gas. This information shall be obtained by consulting your local gas supplier.

Do not obstruct the flow of combustion and ventilation air.

Retain this manual for your reference.

Ne pas pulvériser des aérosols dans le voisinage de cet appareil alors qu'il est en fonctionnement.

Cet appareil ne doit pas être utilisé par des personnes dont les capacités physiques, sensorielles ou mentales sont réduites, ou des personnes dénuées d'expérience ou de connaissance, sauf si elles ont pu bénéficier, par l'intermédiaire d'une personne responsable de leur sécurité, d'une surveillance ou d'instructions préalables concernant l'utilisation de l'appareil.

Cet appareil n'est pas destiné à être utilisé par des enfants et ils doivent être surveillés pour s'assurer qu'ils ne jouent pas avec l'appareil.

Affichez à un endroit bien visible les instructions à suivre dans le cas où l'utilisateur sent une odeur de gaz. Ces informations seront obtenues auprès de votre fournisseur de gaz local.

Ne pas obstruer le flux d'air de combustion et de ventilation.

Conservez ce manuel pour votre référence.

No pulverice aerosoles en las proximidades de este aparato mientras está en funcionamiento.

Este aparato no debe ser utilizado por personas con capacidades físicas, sensoriales o mentales reducidas, o que no tengan la experiencia y los conocimientos adecuados, a menos que estas personas hayan recibido supervisión e instrucciones en cuanto al uso del aparato por la persona responsable de la seguridad de ellas.

Este aparato no debe ser usado por los niños y ellos deben ser supervisados para que no jueguen con el aparato.

No obstruya el flujo del aire combustión y de ventilación.

Guarde este manual para su referencia.



WARNING / AVERTISSEMENT / ADVERTENCIA



Improper installation, operation, adjustment, alteration, service or maintenance can cause property damage, injury or death. Read the installation and operating instructions thoroughly before installing, operating or servicing this equipment. / Toute mauvaise pratique en matière d'installation, de fonctionnement, de réglage, de

modification, d'entretien ou de maintenance peut causer des dommages matériels, des blessures ou la mort. Lisez la totalité des instructions d'installation et d'utilisation avant d'installer, d'utiliser ou d'entretenir cet équipement. / La indebida instalación, operación, ajuste, modificación, servicio o mantenimiento puede ocasionar daños a la propiedad, lesiones o muerte. Lea detenidamente las instrucciones de instalación y de operación antes de instalar, poner a funcionar o dar servicio a este equipo.



Do not lean on or place objects on lip. / Ne vous penchez pas sur oune placez pas des objets sur la lèvres. / No se apoye ni coloque objetos en el labio.



Hot product and surfaces. / Produit et surfaces chaudes. / Producto y superficies calientes.

Do not touch. / Ne pas toucher. / No la toque



Stand clear of product discharge path when discharging hot product. / Écartez-vous du chemin de décharge d'un produit chaud. / Permanezca alejado de la ruta de descarga del producto al vaciar producto caliente.



Keep hands away from moving parts and pinch points. / Gardez les mains loin des pièces mobiles et des points de pincement. / Mantenga las manos lejos de piezas móviles y puntos de presión muy localizada.



Do not fill kettle above recommended level marked on outside of kettle. / Ne remplissez pas la chaudière en excès du niveau recommandé marqué sur la chaudière. / No llene la marmita arriba del nivel recomendado marcado fuera de la marmita.



Unit must be anchored as per manual. / Unité doit être ancrée selon les directives du manuel. / Unidad debe estar fijado según el manual.



Keep appliance and area free and clear of combustibles. / Gardez l'appareil et son entourage libre de tous combustibles. / Mantenga el aparato y el área libres de combustibles.



Do not attempt to operate this appliance during a power failure. / N'essayez pas de faire fonctionner cet appareil lors d'une panne de courant. / No intente poner en marcha este aparato durante un fallo de suministro eléctrico.



Inspect unit daily for proper operation. / Inspectez l'unité tous les jours pour son bon fonctionnement. / Inspeccione diariamente el funcionamiento correcto de la unidad.



Surfaces and product may be hot! Wear protective equipment. / Les surfaces et le produit peuvent être chauds! Portez un équipement de protection. / ¡Las superficies y el producto pueden estar calientes! Utilice equipo protector.



Floor may become slippery from product spillage. / Déversement de produit peut causer de plancher à être glissante. / Derrame de producto puede causar piso a ser resbaladizo.



Unit exhaust contains carbon monoxide. Operate only under a properly functioning hood with adequate make up air. / L'échappement de l'unité émet du monoxyde de carbone. Exploiter uniquement sous une hotte fonctionnant correctement avec une source adéquate d'air d'appoint. / El escape de la unidad contiene monóxido de carbono. Operar solamente bajo una campana en buen funcionamiento con aire de relleno adecuado.



Pressurized device. / Appareil sous pression. / Dispositivo de presión.

Keep clear of pressure relief discharge. / Restez à l'écart de la soupape de sûreté. / Permanezca alejado de la descarga de presión.



Do not climb, sit or stand on equipment. / Il ne faut pas monter, s'asseoir ni se tenir debout sur l'équipement. / No subirse, ni sentarse ni pararse sobre el equipo.

SERVICING / ENTRETIEN / SERVICIO



Shut gas supply off prior to servicing. / Fourniture de gaz fermée au loin avant d'entretenir. / Suministro de gas cerrado apagado antes del mantenimiento.



Remove electrical power prior to servicing. / Coupez l'alimentation électrique avant l'entretien. / Desconecte la energía eléctrica antes de darle servicio.

Risk of electric shock. / Risque de choc électrique. / Riesgo de choque eléctrico.



Ensure kettle is at room temperature and pressure gauge is showing zero or less prior to removing any fittings. / Assurez-vous que la chaudière est à température ambiante et que le manomètre est à zéro ou moins avant de retirer des accessoires. / Asegúrese de que la marmita esté a temperatura ambiente y el manómetro esté mostrando cero o menos antes de retirar cualquier accesorio.



Have a qualified service technician maintain your equipment. / Demandez à un technicien en entretien et en réparation qualifié d'effectuer l'entretien de votre équipement. / Haga que un técnico de servicio calificado mantenga su equipo

INSTALLATION

GENERAL

Installation of the kettle must be accomplished by qualified installation personnel working to all applicable local and national codes. Improper installation of product could cause injury or damage.

This equipment is built to comply with applicable standards for manufacturers. Included among those approval agencies are: UL, A.G.A., NSF, ASME/N.Bd., CSA, CGA, ETL, and others. Many local codes exist, and it is the responsibility of the owner/installer to comply with these codes.

Observe all clearance requirements to provide proper make-up air flow. Do not obstruct the flow of combustion and ventilation air. Check rating plate to ensure that kettle has been equipped to operate with the type of gas available at the installation.

RECEIVING INSPECTION

Before unpacking visually inspect the unit for evidence of damage during shipping.

If damage is noticed, do not unpack the unit, follow shipping damage instructions.

SHIPPING DAMAGE INSTRUCTIONS

If shipping damage to the unit is discovered or suspected, observe the following guidelines in preparing a shipping damage claim.

1. Write down a description of the damage or the reason for suspecting damage as soon as it is discovered. This will help in filling out the claim forms later.
2. As soon as damage is discovered or suspected, notify the carrier that delivered the shipment.
3. Arrange for the carrier's representative to examine the damage.
4. Fill out all carrier claims forms and have the examining carrier sign and date each form.

APPROXIMATE WEIGHTS

Model #	Unit	Unit with shipping box
KGT6T	180 lbs.	220 lbs.
KGT12T	195 lbs.	235 lbs.
KGT12TGB	215 lbs.	255 lbs.

UNCRATING

Caution:

Straps under tension and will snap when cut.

Carton may contain staples and Skid contains Nails.

Use proper safety equipment and precautions.

Unit is heavy use adequate help or lifting equipment as needed.

1. Carefully cut any straps from container.
2. Lift off carton.
3. Inspect for hidden damage. If found refer to "SHIPPING DAMAGE INSTRUCTIONS".
4. Cut strap holding unit.
5. Remove wooden 1x6 holding unit to skid.



6. Remove manual from kettle pot. Write down the model# and serial# of the unit onto the front of this manual.
7. Lift kettle off skid and move kettle to its installation location.
8. Discard packaging material according to local and or state requirements.

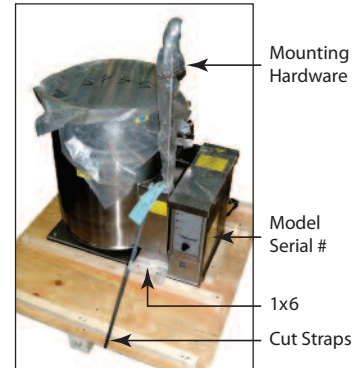

VENTILATION

Gas fired kettles are only to be installed under a ventilation hood in a room which has provisions for adequate make up air. Further information can be obtained by referring to the U.S.A. National Fire Protection Associations NFPA96 regulations. These standards have also been adopted by the National Building Code in Canada.



POSITIONING

CLEARANCE REQUIREMENTS TO COMBUSTIBLE AND NONCOMBUSTIBLE SURFACES.

Model #	Back	Left Side	Right Side
KGT6T	4"	0	0
KGT12T/GB	4"	0	0

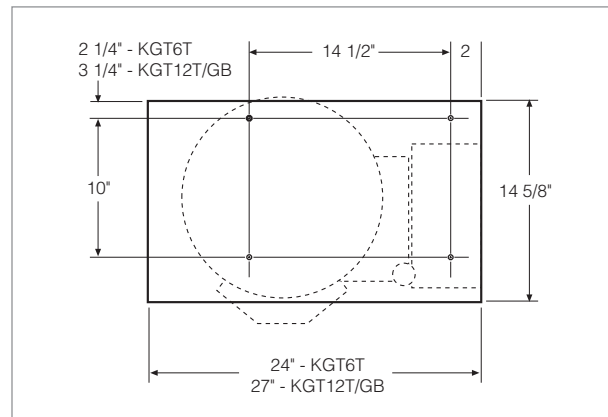

Table-top models must be positioned on a firm, level stand (Cleveland ST-28 or ST-55 recommended), or existing counter top, and bolted in place.

These models are supplied with mounting hardware. This hardware threads into the welded bushing on the underside of the base.

Once the kettle is secure, screw tilt handle into the threaded hole provided at the right side of kettle.

GAS

ENSURE THE GAS SUPPLY MATCHES THE KETTLE'S REQUIREMENTS AS STATED ON THE RATING LABEL.

Installation must conform, with local codes or in the absence of local codes, with the National Fuel Gas Code ANSI Z223.1/NFPA 54, or the Natural Gas and Propane Installation Code, CSA B149.1.

The appliance and its individual shut-off valve must be disconnected from the gas supply piping system during any pressure testing of that system at test pressures in excess of 1/2 psi (3.45 kPa).

The appliance must be isolated from the gas supply piping system by closing its individual manual shut-off valve during any pressure testing of the gas supply piping system at test pressures equal to or less than 1/2 psi (3.45 kPa).

It is recommended that a sediment trap (drip leg) be installed in the gas supply line. If the gas pressure exceeds 14" water column, a pressure regulator must be installed, to provide a maximum of 14" water column gas pressure to the gas control valve.

Use a gas pipe joint compound which is resistant to L.P. gas. Test all pipe joints for leaks with soap and water solution. Ensure that the gas pressure regulator is set for the manifold pressure indicated on the gas rating plate.

1. Removed supplied manual shut-off valve and establish mounting location.
2. Add union and piping as required.
3. Connect the gas line to the manual shut-off valve.

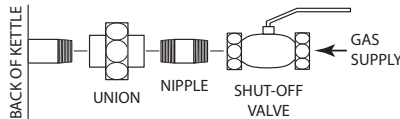

ELECTRICAL

ENSURE THE ELECTRICAL SUPPLY MATCHES THE KETTLE'S REQUIREMENTS AS STATED ON THE RATING LABEL.

A cord and plug are supplied with the unit. Simply plug the unit into any grounded outlet rated for a minimum of 10 amps.

WARNING:

Electrical Grounding Instructions.

This unit is equipped with a three-prong (grounding) plug for your protection against shock hazard and should be plugged directly into a properly grounded three-prong receptacle. Do not cut or remove the grounding prong from this plug.

The kettle must be electrically installed and grounded in accordance with local codes, or in the absence of local codes, with National Electrical Code, ANSI/NFPA 70 (USA) or the Canadian Electrical Code, CSA C22.2, (Canada).

Standard supply voltage is 115 volts A.C., however, optional A.C. voltages can be supplied on special order. A separate fused disconnect switch must be supplied and installed in the high voltage electrical supply line.

The wiring diagram is located under the cover of kettle control box.

NOTE: Units are tested on a in-house ground fault system. However, there is no guarantee the unit will work on all ground fault systems. If you are having problems you can hard wire the unit.

CLEANING

After installation the kettle must be thoroughly cleaned and sanitized prior to cooking.

INSTALLATION CHECKS

Although the kettle has been thoroughly tested before leaving the factory, the installer is responsible for ensuring the proper operation of kettle once installed.

1. Before turning the kettle on, read the vacuum/pressure gauge. The gauge's needle should be in the green zone. If the needle is in the "VENT AIR" zone, follow air venting procedure.
2. Unit has been thoroughly checked for gas leaks at the factory however the installer should check all connections using soap bubble or gas detector for any leaks which may have resulted from shipping or installation.
3. Supply power to the kettle by placing the fused disconnect switch to the "ON" position.
4. Open gas shut-off valve to turn on main gas supply..
5. Turn the temperature control dial to "1" (Min.). The green LED light should remain lit, indicating the burner is lit, until the set temperature is reached. Then the green light will cycle on and off, indicating the burner is cycling on and off to maintain temperature.
6. Tilt the kettle forward. After a few seconds the red "LOW WATER" light should be lit when the kettle is in a tilted position. This light indicates that the burner has automatically been shut off by the kettle's safety circuit. This is a normal condition when the kettle is in a tilted position.
7. Raise the kettle to the upright position. The red "LOW WATER" light should go out when the kettle is upright.
8. Turn the temperature control dial to "10" (Max.) and allow the kettle to preheat. The green light should remain on until the set temperature is reached. Then the green light will cycle ON and OFF, indicating the burner is cycling ON and OFF to maintain temperature.
9. Turn unit OFF.

WATER

The sealed jacket of the gas-fired kettle is precharged with the correct amount of a water-based formula, and therefore, no water connection is required to the kettle jacket.

The kettle can be equipped with optional hot and cold water taps, requiring 1/2" copper tubing supply lines.

OPERATING INSTRUCTIONS



1. **Tilting Handle** - Used for tilting the kettle.
2. **Vacuum/Pressure Gauge** - Indicates steam pressure and vacuum.
3. **Pressure Relief Valve** - Pressure safety device.
4. **Heat Indicator Light (Green)** - Cycles ON-OFF with burner.
5. **Low Water Indicator Light (Red)** - When lit, indicates a low water condition.
6. **Ignition Failure Indicator Light (Amber)** - Indicates failure of heating system to ignite.
7. **Dial** - Turns kettle ON/OFF and adjusts the cooking temperature.
8. **Kettle Tilt Lock** - Prevents unit from accidental tilting.
9. **Water Level Sight Glass** - Displays water level in steam jacket.

⚠ WARNING

If for any reason this unit is not functioning correctly **DO NOT OPERATE**. Contact your authorized service agent.



OPERATING THE KETTLE

NOTE: If you are cooking an egg or milk product, do not pre-heat kettle.

1. Perform DAILY PRE-STARTUP INSPECTION (see Maintenance).
2. Preheat the kettle by turning the dial to the desired temperature setting (see "Temperature Range Chart"). The Heat Indicator Light (Green) will remain lit, indicating the unit is heating, until the temperature setting is reached. When the green light goes off, the burners are off, and preheating is complete.
3. Place food product into the kettle. The Heat Indicator Light (Green) will cycle on and off indicating the burners are cycling on and off to maintain the set temperature.

NOTE: Do not fill kettle above recommended level marked on outside of kettle.



4. When cooking is completed turn dial to the "OFF" position.

NOTE: A five minute complete shut-of period is required before relighting.

5. Pour the contents of the kettle into an appropriate container by tilting the kettle forward. Care should be taken to pour slowly enough to avoid splashing off the product.

Temperature Control Setting	Approximate Product Temperature	
	°F	°C
MIN.	120	49
1.	130	54
2.	145	63
3.	160	71
4.	170	77
5.	185	85
6.	195	91
7.	210	99
8.	230	110
9.	245	118
MAX.	265	130

NOTE: Certain combinations of ingredients will result in temperature variations

Temperature Range Chart

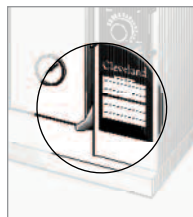

KETTLE TILT LOCK

Your unit is equipped with a lock to prevent accidental tilting. The following procedure should be used to tilt the kettle.

1. Grasp the tilt handle.
2. Hold the latch down to unlock tilting mechanism.
3. Pull the handle to tilt kettle.
4. To lock, return the kettle to its upright position and push handle back.

CLEANING INSTRUCTIONS



CARE AND CLEANING

Cooking equipment must be cleaned regularly to maintain its fast, efficient cooking performance and to ensure its continued safe, reliable operation. The best time to clean is shortly after each use (allow unit to cool to a safe temperature).



Chloride Cleaners

Do not use detergents or cleansers that are chloride based or contain quaternary salt.



Wire Brush & Scrapers

Do not use a metal bristle brush or scraper.



Steel Pads

Steel wool should never be used for cleaning the stainless steel.

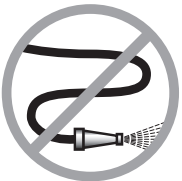

High Pressure Spray Hose

Unit should never be cleaned with a high pressure spray hose.



Do not leave water sitting in unit when not in use.

CLEANING INSTRUCTIONS

1. Turn unit off.
2. Remove drain screen (if applicable). Thoroughly wash and rinse the screen either in a sink or a dishwasher.
3. Prepare a warm water and mild detergent solution in the unit.
4. Remove food soil using a nylon brush.
5. Loosen food which is stuck by allowing it to soak at a low temperature setting.
6. Drain unit.
7. Rinse interior thoroughly.
8. Using mild soapy water and a damp sponge, wash the exterior, rinse, and dry.

NOTES

- ⇒ For more difficult cleaning applications one of the following can be used: alcohol, baking soda, vinegar, or a solution of ammonia in water.
- ⇒ Leave the cover off when the kettle is not in use.
- ⇒ For more detailed instructions refer to Stainless Steel Equipment Care and Cleaning (www.nafem.org/resources/stainlesssteelfinal.doc) on Nafem's website (www.nafem.org).

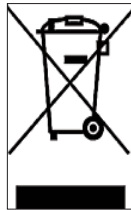

DISPOSAL INSTRUCTIONS

This unit is recyclable. Do not dispose in landfill.

The unit may contain rust inhibitor and or antifreeze within the jacket. Drain unit and dispose following Federal, State and local regulations.

The majority of the unit is composed of stainless steel. Other alloys and electrical components make up a small percentage of the total. Follow Federal, state and local regulations for disposal.



PREVENTATIVE MAINTENANCE

FOR MAINTENANCE AND REPAIRS CONTACT YOUR AUTHORIZED MANITOWOC SERVICE AGENCY
AND HAVE A QUALIFIED SERVICE TECHNICIAN MAINTAIN YOUR EQUIPMENT.



WARNING

If for any reason this unit is not functioning correctly DO NOT OPERATE. Contact your authorized service agent.

Cleveland Range equipment requires little preventative maintenance. We do however provide the following chart as a guideline for inspection and maintenance to keep your unit functioning at 100%.



DAILY PRE-STARTUP INSPECTION

1. Tilt Handle (A) is tight and knob is in place.
2. Kettle Tilt Lock (B) is functioning correctly.
3. Pressure Gauge (C) is in the green when unit is cold.
4. Green Light (D) comes on when unit is energized.
5. Red Light (E) comes on when unit is tilted.



SIX MONTH SERVICE INSPECTION

1. Perform daily startup inspection.
2. Screws holding top cover are in place and tight.
3. Flue gasket is in place and in good condition.
4. Burner is held firmly in place and in good condition.
5. Fasteners securing base and support leg are in place and tight.
6. Perform pressure relief valve periodic test (see Pressure Relief Valve Periodic Testing Procedure).
7. Adequate exhaust and makeup air is supplied to working area.

YEARLY SERVICE INSPECTION

1. Perform six month service inspection.
2. Perform free air calculation (see FREE AIR CALCULATION).
3. Perform safety inspection using SAFETY INSPECTION CHECKLIST found in the MAINTENANCE PROCEDURES.

SAFETY INSPECTION CHECKLIST

NOTE: The following instructions are intended for use by qualified service personnel. The following steps should be completed **IN SEQUENCE**.



A/ KETTLE PREPARATION

1. Disconnect main power at fused disconnect switch.
2. Kettle should be cold. If necessary add water to kettle pot to cool unit.
3. The pressure gauge should now show a vacuum and have no indication of leakage. If gauge looks damaged replace gauge.
4. Gauge must be showing a vacuum prior to proceeding. If not check for leaks, and repair kettle prior to proceeding. Refer to REFERENCE SECTION (KETTLE VENTING INSTRUCTIONS).



Pressure Gauge in Vacuum.

B/ MECHANICAL CHECKS

1. Inspect controls, replace damaged seals, switches, LED's etc..
2. Remove the console cover and check that the seal is not cracked or split. Replace seal, screws, missing or worn nylon anchor nuts. **Leave cover off.**
3. Remove the kettle bottom cover and check that the seal is not cracked or split. **Leave cover off.**
- 4A. For units with tilt handle-
 - A. Check handle for tightness. If loose apply lock tight and reinstall. Check handle knob is on end of handle and firmly tightened. If missing replace, if loose apply lock tight and reinstall.
 - B. Check that kettle tilts smoothly and there is no excessive wear in the trunnion bearings. Add grease to nipples as required.
- 4B. For units with tilt crank-
 - A. Check that the kettle tilts smoothly. If there is excess play adjust the worm to gear clearance with Locking Nuts or Adjusting Screw as required.
 - B. Check that there is no excessive wear in the trunnion bearings.
 - C. Apply grease to gear teeth and bearings.

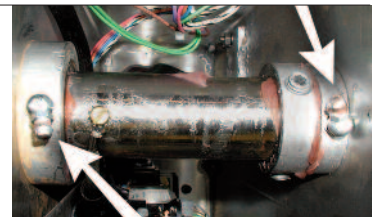

4A. Grease Nipples.

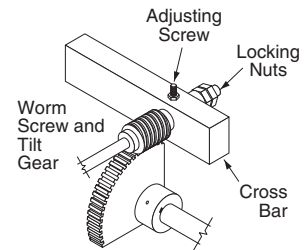

4B. Illustration inverted for clarity.

C/ MARINE LOCK TEST

1. Check that lock mechanism is not bent or damaged.
2. Check that lock clears stop pin on side box without rubbing when kettle is tilted.
3. Check side to side play. Lock should remain fully over stop pin when pushed to it's maximum side to side play.

D/ LOW WATER LEVEL PROBE:

Installation Check:

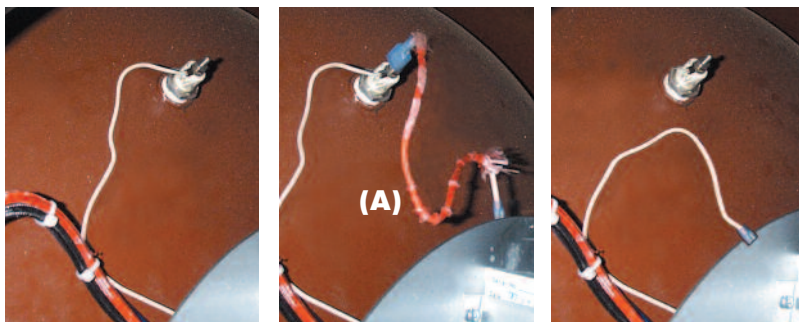

✓ Probe properly attached

✗ Probe bypassed by running (A) an additional wire

✗ Probe bypassed by (B) grounding the connecting wire

Functional Test:

1. Turn main power on at fused disconnect switch.
2. Turn kettle on and set temperature to maximum.
3. Green light will come on and contactors close.
4. Tilt kettle over. After approximately a five-second delay the red light will come on, green light go off and the contactors will disengage.
5. Turn kettle upright. Green light will come back on and contactors reengage.
6. Turn kettle off
7. If unit does not function as above, make required repairs.
8. Disconnect main power at fused disconnect switch.

E/ SAFETY THERMOSTAT

Installation Check:

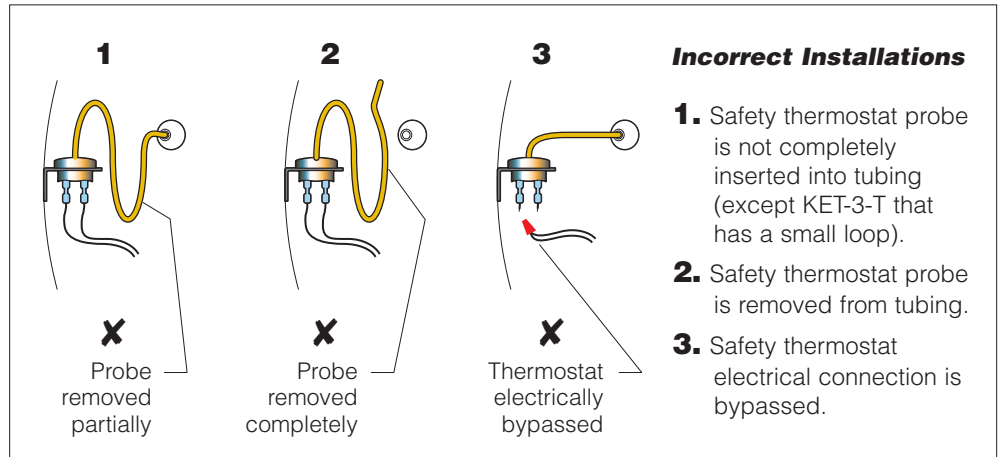
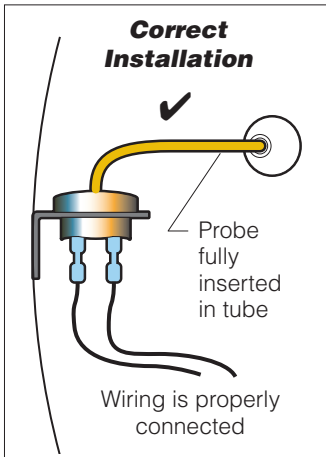

F/ SAFETY VALVE

Installation Check:

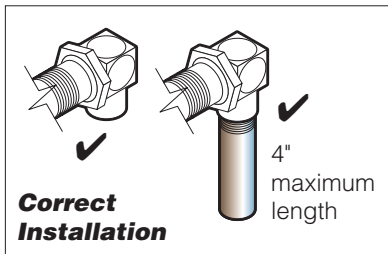

The above illustrations show the variations of factory installed Safety Valves. **Any modifications are unacceptable.**

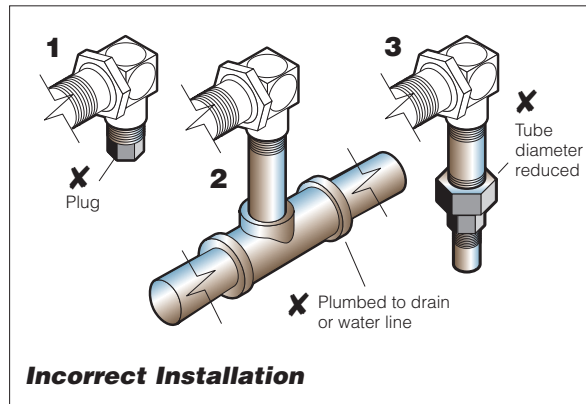

Physical Checks

1. Check that the PSI rating on the valve matches MAWP (maximum allowable working pressure) on the plate welded to the kettle.
 2. Check that the Safety Valve has a "UV" stamp.
 3. Check that the valve is not damaged in any way.
- If any of the above criteria is not met, replace valve.

Pressure Relief Valve Periodic Testing Procedure

1. With the kettle empty, set On-Off Switch/Temperature Control to "10" (Max.). Allow the kettle to heat until the unit cycles off.
2. Switch On-Off Switch/Temperature Control to "0" (Off) and disconnect main power at fused disconnect switch.
3. Stand to the side of the pressure relief valve discharge tube and pull valve open for a maximum of one second. Repeat test three to four times. Each time the mechanism should move freely and be accompanied by a rapid escape of steam.

If valve appears to be sticking replace pressure relief valve.

If foreign material is discharged then drain kettle and replace pressure relief valve.

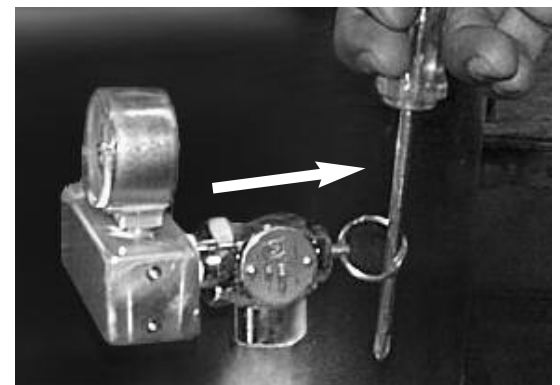

G/ CALIBRATING PROCEDURE

1. Kettle must be empty when this procedure is executed.
2. Insure the unit has a vacuum before you begin calibrating procedures. If unit requires venting see REFERENCE SECTION (KETTLE VENTING INSTRUCTIONS).
3. Turn kettle ON and set temperature dial to 10 (Max.).
4. Allow the unit to cycle twice (the green light must go on and off).
5. Check temperature of the inner kettle surface with a digital surface thermometer. For accurate readings move probe around bottom of kettle to locate the hottest location.
6. Temperature should be between 260° F and 265° F. Pressure gauge should read between 20 - 28 PSI.
7. Using a screw driver adjust temperature by turning the potentiometer on the black box. Turn very little. Turn clockwise to INCREASES and counter-clockwise to DECREASE temperature.
8. Allow the unit to cycle twice.
9. Re-check temperature.
10. Repeat steps 7 - 9 until unit is calibrated.

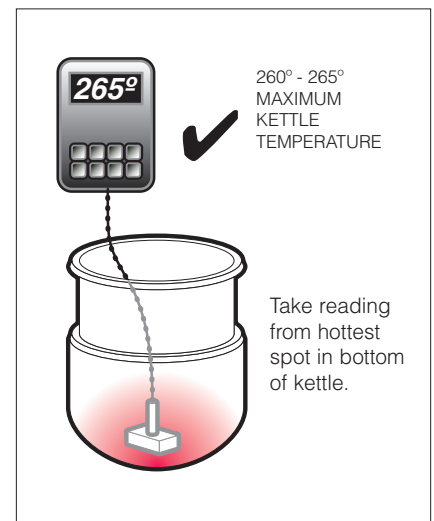

OPERATING SEQUENCES

1. Turn On-Off / Temperature Dial*
 - 14 volt transformer is energized and powers solid state control system.
 - Temperature knob is turned up and control box calls for heat.
 - Relay (RY-1) closes and powers 24 volt transformer.
 - Ignition control box is powered.
3. Ignitor Sparks*
 - Gas valve is energized.
 - Ignitor sparks and ignition occurs.
4. Temperature Reached*
 - Solid state controls senses temperature reached.
 - Relay (RY-1) opens and 24 volt transformer loses power.
 - Ignition control box is turned off.
 - Gas valve closes.
5. Maintaining Temperature*
 - Solid state controls senses temperature drop.
 - Relay (RY-1) closes and powers 24 volt transformer.
 - Ignitor control box is powered.
 - Steps three and four are repeated.

SOLID STATE CONTROL SEQUENCE

Our solid state controls consist of the following components.

On-Off / Temperature* Provides or interrupts electrical power to the control system.

Dial (Potentiometer) Rotate to change resistance from 0 to 50,000 ohms. This resistance is compared to the resistance on the thermistor using a voltage comparator circuit inside the control box.

If the resistance is lower than the thermistor resistance then the control box will provide 14v dc to pin #8. The green indicator light illuminates and the control relay (RY-1) is energized closed to provide power to the heating system.

Control Box* Analyzes inputs from water level probe, tilt switch, potentiometer, thermistor. Energizes control relay (RY-1)

Water Level Probe* Senses water in jacket.

Tilt Switch When kettle is in upright position tilt switch is closed to complete circuit between pin #8, the relay (RY-1) and green indicator light.*

Thermistor* The thermistor resistance decreases as temperature increases. When the thermistor resistance equals the potentiometer then 14v dc is removed from pin #8. The control relay (RY-1) returns to the normally open position.

Green LED Light Indicates that the control box is calling for heat. Pin #8 powered.

Red LED Light Indicates that the water level probe is not immersed in water. Not enough water in the jacket or kettle tilted.

Relay (RY-1) When energized allows the heating circuit to function. Electric elements or gas burner system.

NOTES:

* A ground loop circuit must be established between kettle body, water in jacket, water level probe and control box. If this loop is present, it indicates that there is sufficient water in the kettle for safe operation.

* If there is not sufficient water in the jacket then the loop is broken and the control box will prevent 14v DC from being supplied to pin #8. The control relay (RY-1) will remain (or return) to the normally open position and the unit cannot heat. The red LED light will be illuminated.

SERVICE PROCEDURES

FOR MAINTENANCE AND REPAIRS CONTACT YOUR AUTHORIZED MANITOWOC SERVICE AGENCY AND HAVE A QUALIFIED SERVICE TECHNICIAN MAINTAIN YOUR EQUIPMENT.



KETTLE VENTING INSTRUCTIONS

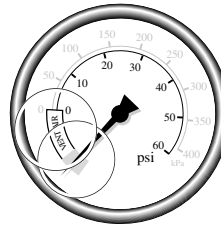
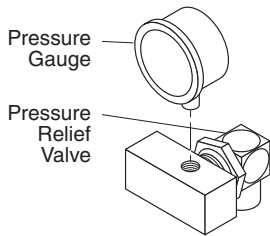
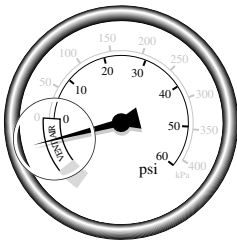

- Turn kettle OFF. Add cold water to kettle until its surface temperature is below 100°F. The pressure gauge needle should be in the green zone, indicating a vacuum in the kettle's jacket.

The following procedure should be followed when the Vacuum/Pressure Gauge needle is in the "VENT AIR" zone:

NOTE: Check for and eliminate leaks prior to venting (See Repairing Leaks in Steam Jacketed Kettle Fittings.



DANGER: PRESSURE RELIEF VALVE WILL EXHAUST HIGH TEMPERATURE STEAM. CONTACT WITH SKIN COULD RESULT IN SERIOUS BURNS. KEEP FACE, HANDS AND BODY CLEAR OF DISCHARGE.

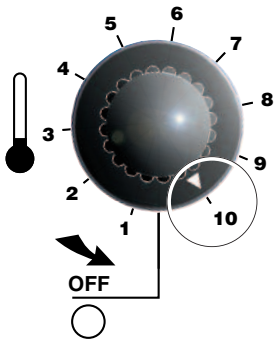

- Turn kettle ON and set dial to **10** (Max.), heat the empty kettle until unit cycles off.

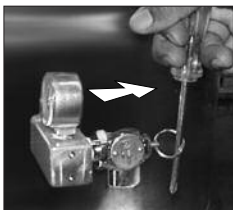

- Vent kettle by pulling safety valve ring 8-10 times in short 2-3 second blasts with a 5 second interval between pulls.

NOTE: If unit cycles ON, stop venting and wait for kettle to cycle OFF before continuing.

REPAIRING LEAKS IN STEAM JACKETED KETTLE FITTINGS

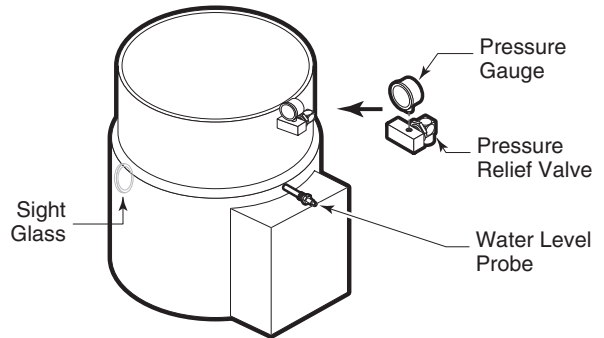

If unit will not hold a vacuum the most likely cause is a leak at one of the components threaded fittings, or within the component itself.

There are two methods available for preventing leaks. The advantage of the "Preferred Method" is that you eliminate all potential leaks.

Preferred Method: Replace (using teflon tape) Pressure Relief Valve, Pressure Gauge, Water Level Probe and Sight Glass.

Second Method: Remove and reinstall (using teflon tape) all of the above four components. If unit continues to lose vacuum replace components as per "Preferred Method".

CALIBRATING PROCEDURE

1. Insure the unit has a vacuum before you begin calibrating procedures. If unit requires venting refer to Kettle Venting Instructions.
2. Turn dial to "10" (Max.).
3. Allow the unit to cycle twice.
4. Check temperature of the inner kettle surface with a digital surface thermometer.
5. Temperature should be between 260° F and 265° F.
6. Using a screw driver adjust temperature by turning the potentiometer on the black box. Turn very little. Turn clockwise to INCREASES and counter-clockwise to DECREASE temperature.
7. Allow the unit to cycle twice.
8. Check temperature of the inner kettle surface with a digital surface thermometer.
9. Repeat steps 4. through 8. until unit is calibrated.

PRESSURE RELIEF VALVE PERIODIC TESTING PROCEDURE

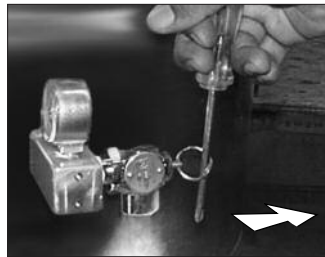

DANGER:
PRESSURE RELIEF VALVE WILL EXHAUST HIGH TEMPERATURE STEAM. CONTACT WITH SKIN COULD RESULT IN SERIOUS BURNS. KEEP FACE, HANDS AND BODY CLEAR OF DISCHARGE.

WARNING: Kettle surface will be hot and steam will be released during testing. Take necessary precautions including the use of gloves and eye protection to prevent personal injury.

1. With the kettle empty, turn dial to "10" (Max.). Allow the kettle to heat until the unit cycles off.
2. Turn dial to "0" (Off).
3. Stand to the side of the pressure relief valve discharge tube and pull valve open for a maximum of one second. Repeat test three to four times. Each time the mechanism should move freely and be accompanied by a rapid escape of steam.

If valve appears to be sticking replace pressure relief valve.

If foreign material is discharged then drain kettle and replace pressure relief valve.

If Low Water Light comes on after this procedure, you need to add water to the jacket (see RESERVOIR FILL PROCEDURE).

RESERVOIR FILL PROCEDURES

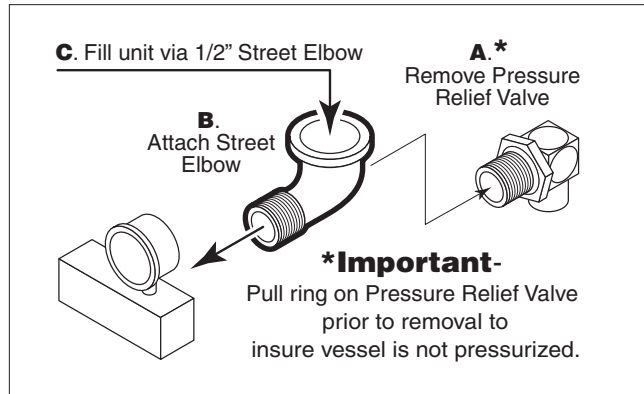

DISTILLED WATER REQUIREMENTS

Kettle Capacity	When red "Low Water Light" comes on, add distilled or bottled water.
6 gallon	70 ounces
12 gallon	120 ounces

1. Ensure kettle is at room temperature and pressure gauge showing zero or less pressure.
2. Remove electrical plug from power source.
Shut off gas supply to kettle.
3. Pull Pressure Relief Valve (A) open to insure vessel is not pressurized.
4. Remove Pressure Relief Valve (A).
5. Replace Pressure Relief Valve (A) with 1/2" Street Elbow (B).
6. Add distilled or bottled water (C) through the Street Elbow (B), using a funnel if necessary. Fill the unit to the high level mark on the Sight Glass.
7. Apply a thread sealant (i.e. Teflon tape) to the Pressure Relief Valve's (A) thread and replace.
8. Reconnect gas and electrical supplies.
9. The kettle must now be vented. (Refer to the KETTLE VENTING INSTRUCTIONS).

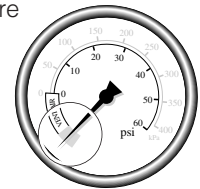

KETTLE JACKET CLEANOUT AND PASSIVATION PROCEDURES

The following procedure should be performed at least once every three years to prevent possible corrosion and ensure the optimum life of the kettle.

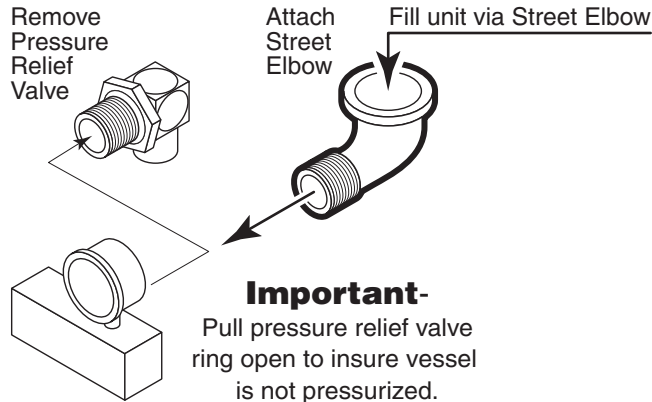

RUST INHIBITOR

Use a “radiator rust inhibitor” that can be purchased at your local automotive centre. It should not contain any anti-freeze and preferably no lubricant.

To ensure satisfactory mixing follow the manufacturer’s instructions.

DISPOSAL - Follow all Federal, State and local codes when disposing of product.

10. Tilt kettle upright, apply a thread sealant (i.e. Teflon tape) to the sight glass threads and replace.
11. Refer to chart below to determine the required volume of water.

Kettle Size	Volume of Mixture	
	U.S. Gal.	Liters
6 U.S. Gal.	1.6	5.8
12 U.S. Gal.	2.2	8.3

PROCEDURE



1. Ensure kettle is at room temperature and pressure gauge showing zero or less pressure.
2. Shut off and disconnect gas supply.
3. Remove electrical plug from power source.
4. Remove bolts holding kettle to tabletop.
5. Pull ring on pressure relief valve to insure there is no pressure within the kettle jacket.
6. Remove pressure relief valve.
7. Replace pressure relief valve with street elbow (see above illustration).
8. Remove sight glass from left side of kettle.
9. Tilt kettle on its side (sight glass opening facing downwards) and allow to drain. Flush out with water.
12. In a separate container mix water with the required rust inhibitor.
13. Fill jacket via the street elbow with the mixture.
14. Remove street elbow.
15. Apply a thread sealant (i.e. Teflon tape) to the pressure relief valve and replace.
16. Reconnect gas and electrical supplies.
17. Turn kettle on, vent and heat to high for 1/2 hour.
18. Cool kettle.
19. Repeat steps 5-15.
20. Replace bolts holding kettle to tabletop.
21. Reconnect gas and electrical supplies.
22. Turn kettle on and vent kettle.

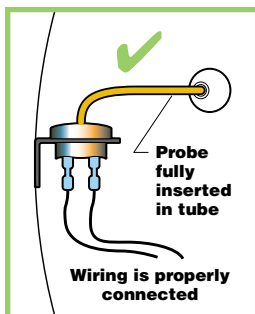

SAFETY THERMOSTAT CONNECTION

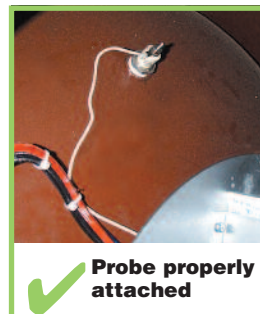

LOW WATER LEVEL PROBE CONNECTION

NATURAL GAS TO PROPANE CONVERSION KIT

(for KGT6T & KGT12T/GB)



THIS CONVERSION KIT SHALL ONLY BE INSTALLED BY A QUALIFIED SERVICE AGENCY

For use at 0-2000 feet elevation on Honeywell valves Model 8305. For higher elevations consult the factory.

PART #'s KE003716-1 kit for KGT6T (34,000 BTU)
KE003716-2 kit for KGT12T/GB (52,000 BTU)

Includes parts listed below:

PART #	DESCRIPTION	QTY.
KE53406-2	Orifice, 1.75mm, Propane Gas (for KGT6T)	1
KE53406-12	Orifice, 2.15mm, Propane Gas (for KGT12T/GB)	1
KE603911-1	Conversion Label (for KGT6T)	1
KE603911-2	Conversion Label (for KGT12T/GB)	1
KE55240-4	Gas Valve Conversion Kit	1
KE603910	Instruction Sheet	1

⚠ WARNING:

This conversion kit shall be installed by a qualified service agency in accordance with the manufacturer's instructions and all applicable codes and requirements of the authority having jurisdiction. If the information in these instructions is not followed exactly, a fire, and explosion or production of carbon monoxide may result causing property damage, personal injury or loss of life. The qualified service agency is responsible for the proper installation of this kit. The installation is not proper and complete until the operation of the converted appliance is checked as specified in the manufacturer's instructions supplied with the kit.

⚠ CAUTION

The gas supply shall be shut off prior to disconnecting the electrical power, before proceeding with the conversion.

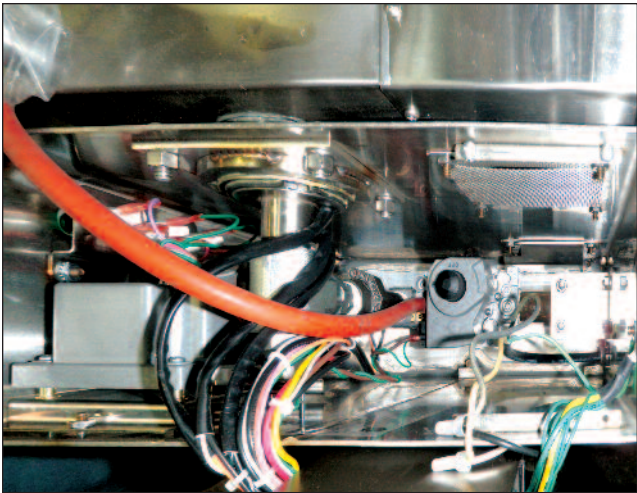

Photo showing manometer hooked up to outlet side of valve.

INSTRUCTIONS

1. Shut off gas supply.
2. Unplug electrical cord from source.
3. Replace the gas orifice with the one supplied.
4. Remove cover.
5. Remove component mounting plate to get access to the gas valve.
6. Follow instructions in KE55240-4, GAS VALVE CONVERSION KIT to convert gas valve to 10 in W.C.
7. Check inlet pressure is between 12-14 inches W.C.
8. Using instructions from kit KE55240-4 check input rate of unit.
9. On the underside of the console cover with indelible marker place the following information: Company, Name, Address & Date of Conversion.
10. Reassemble unit.
11. Install conversion label as close as possible to the existing rating plate.



12. Reconnect gas and electrical supply.
13. Test kettle operation buy following "INSTALLATION CHECK" section of the service manual.

REPAIRING LEAKS IN STEAM JACKETED KETTLE FITTINGS

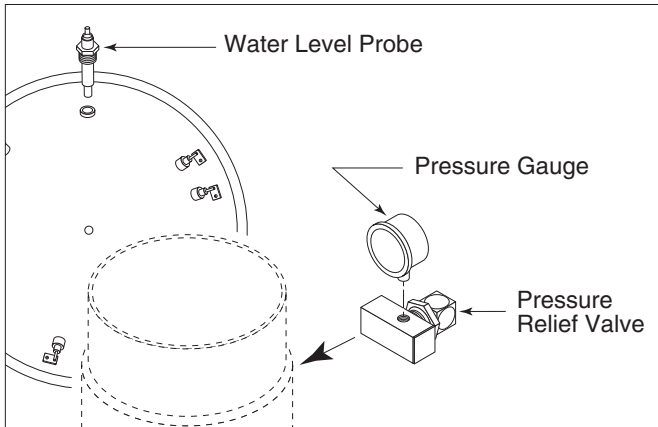

If unit will not hold a vacuum the most likely cause is a leak at one of the fittings. Often, the easiest way to eliminate a leak is reseal the suspect areas.

1. Water Level Probe Remove, clean threads, apply teflon thread sealant and reinstall.
2. Pressure Relief Valve **A/** Inspect for signs of leaks. Replace if required.
B/ Remove, clean threads, apply teflon thread sealant and reinstall.
3. Pressure Gauge **A/** Inspect face of gauge. If it contains moisture on the inside of face replace.
B/ Remove, clean threads, apply teflon thread sealant and reinstall.

THERMISTOR REPLACEMENT

1. Disconnect main power at fused disconnect switch.
2. Remove bottom cover.

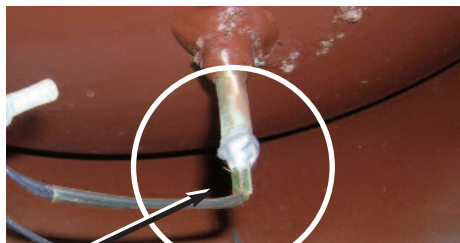

3. Locate thermistor.



4. Cut pigtail connection off.

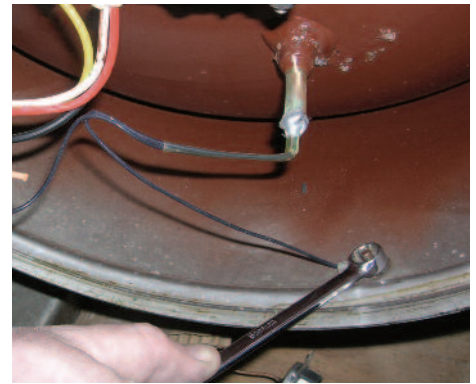

5. Remove wire from ground lug.
6. Remove thermistor from tube.



7. Add new "eye" connector to one of the thermistor leads and fasten to ground lug.

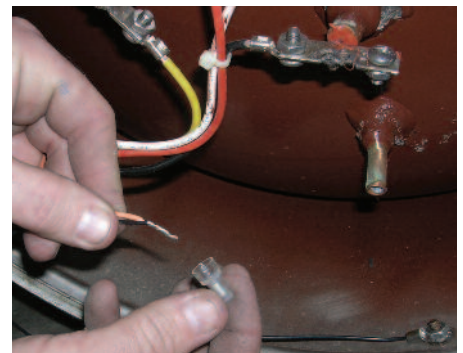

8. Connect orange wire to the other thermistor lead and fasten with pigtail connector.



9. Insert thermistor as far as possible into tube and hold in place. While holding add silicon to secure thermistor into tube. Insure silicon completely surrounds tube and thermistor.

10. Replace covers, reconnect power and test operation.

LUBRICATION PROCEDURE

Lubricate the following parts every three months to insure smooth operation and reduce wear.

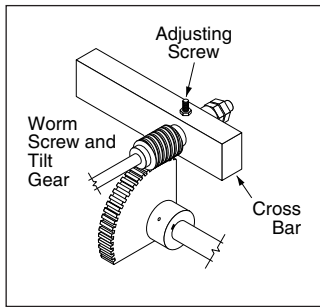

TRUNNION HOUSING, WORM SCREW AND TILT GEAR

These parts are accessed through the top cover of the console.

Apply grease to gear teeth. Check for excessive play and adjust with adjusting screw located on top of cross bar.

KETTLE TRUNNIONS

On the left hand side of the kettle there are two grease nipples on the top back portion of the trunnion housing. On the right hand side of the kettle you must remove the console cover to access the two grease nipples.

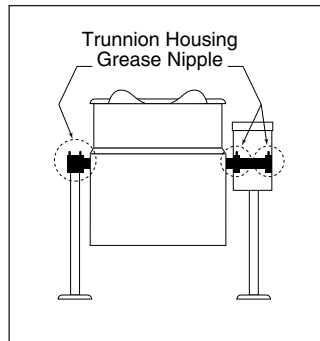

HINGE ADJUSTMENT INSTRUCTIONS

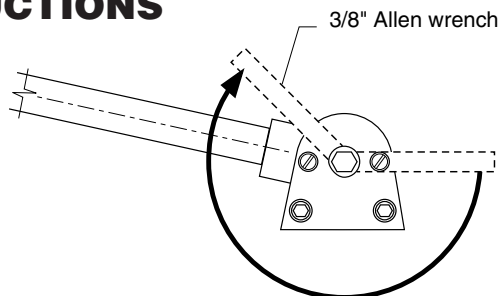

1. Insert 3/8" Allen wrench.
2. Turn clockwise to relieve tension on spring.
3. While tension is released remove one of the two slotted screws.
4. To prevent Allen wrench from springing back abruptly while the second slotted screw is removed, insert a pin (approximately 1/8") in the hole where the first slotted screw was removed from.
5. Remove second slotted screw.
6. While holding Allen wrench remove pin.
7. Turn Allen wrench clockwise to tighten or counter-clockwise to loosen tension to produce desired effect.
8. Re-insert pin in one of the two holes.
9. Tighten one slotted screw in the other hole (it may be necessary to turn Allen wrench slightly to align holes).
10. Remove pin and repeat step number 9 for other slotted screw.

SSK SOLID STATE CONTROL TEST INSTRUCTIONS

SSK Solid State Control (part number KE00458-1)

SWITCH	<input type="radio"/>	SWITCH - Push for 5 seconds to enter TEST #1 Press again for TEST #2 and again for TEST #3
CPU	<input type="radio"/>	CPU - Rapid flashing during normal operation TEST #1 = 1 flash/sec Water level test TEST #2 = 2 flash/sec Thermistor test TEST #3 = 3 flash/sec Heater Output test
DIAGNOSTIC LED	<input type="radio"/>	TEST #1 GREEN Probe senses water RED No water sensed TEST #2 GREEN Thermistor is sensed ORANGE Thermistor is shorted RED Thermistor is open circuit
POTENTIOMETER	<input type="radio"/>	LOW WATER
	<input type="radio"/>	HEATER OUTPUT
	<input type="radio"/>	TEST #3 GREEN voltage output to relay for 20 seconds. Normal operation LED matches Front heater (green) LED

THIS CONTROL BOX MUST BE CALIBRATED WHEN REPLACED
(see back for test and calibration instructions)

1. If required remove board from holding bracket for better access.
 2. Turn unit on and set to 10 (maximum).
 3. Push and hold the SWITCH button for approximately 5 seconds until the CPU starts to flash 1 flash/second. You are now in TEST #1. Output to 12v relay is disabled. With kettle upright the DIAGNOSTIC LED should be green, with kettle tilted it should be red.
 4. Push SWITCH button. The CPU starts to flash 2 flash/second. You are now in TEST #2. Check the DIAGNOSTIC LED for indication of the temperature probe status.
 5. Push SWITCH button. The CPU starts to flash 3 flash/second. You are now in TEST #3. The HEATER OUTPUT LED should light for 20 seconds and power to the relay should energize the 12v relay for the heat source.
- After 20 seconds test mode is exited and unit reverts to normal operation.

WIRING DIAGRAM

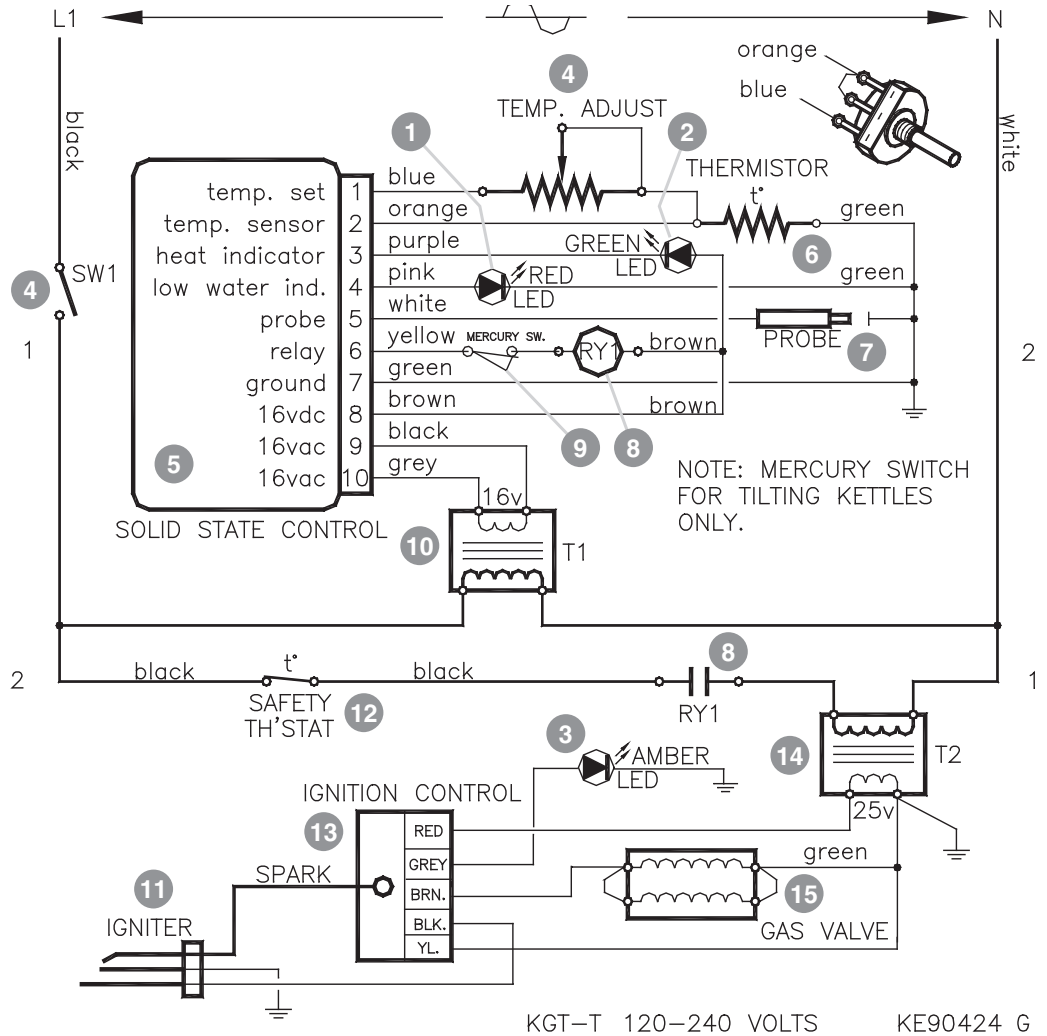

ITEM #	PART #	DESCRIPTION
1.	KE55486-2	L.E.D., RED
2.	KE55486-3	L.E.D., GREEN
3.	KE55486-4	L.E.D., AMBER
4.	SE00114	POTENTIOMETER WITH ON/OFF SWITCH, C/W RUBBER BOOT
5.	KE00458-1	SOLID STATE CONTROL BOX
6.	KE00515	THERMISTOR ASSEMBLY
7.	KE50556-1	WATER LEVEL PROBE
8.	KE50753-7	RELAY
9.	KE50294-1	MERCURY SWITCH
10.	KE53838-27	TRANSFORMER, 120/14V OPTION
	KE53838-21	TRANSFORMER, 240/16V OPTION
11.	KE53437-2	IGNITER
12.	KE55069-6	SAFETY THERMOSTAT
	KE53469-2	IGNITION CONTROL #05-296466-151
14.	KE53838-20	TRANSFORMER, 120/24V OPTION
	KE53838-18	TRANSFORMER, 240/24V OPTION
15.	KE55240-8	GAS VALVE, NATURAL
15.		For conversion to propane gas see GAS VALVE REPLACEMENT KIT

SERVICE PARTS

WARRANTY

Our Company supports a worldwide network of Maintenance and Repair Centers. Contact your nearest Maintenance and Repair Centre for replacement parts, service, or information regarding the proper maintenance and repair of your cooking equipment.

In order to preserve the various agency safety certification (UL, NSF, ASME/Ntl. Bd., etc.), only factory-supplied replacement parts should be used. The use of other than factory supplied replacement parts will void warranty.

FAUCET ASSEMBLY

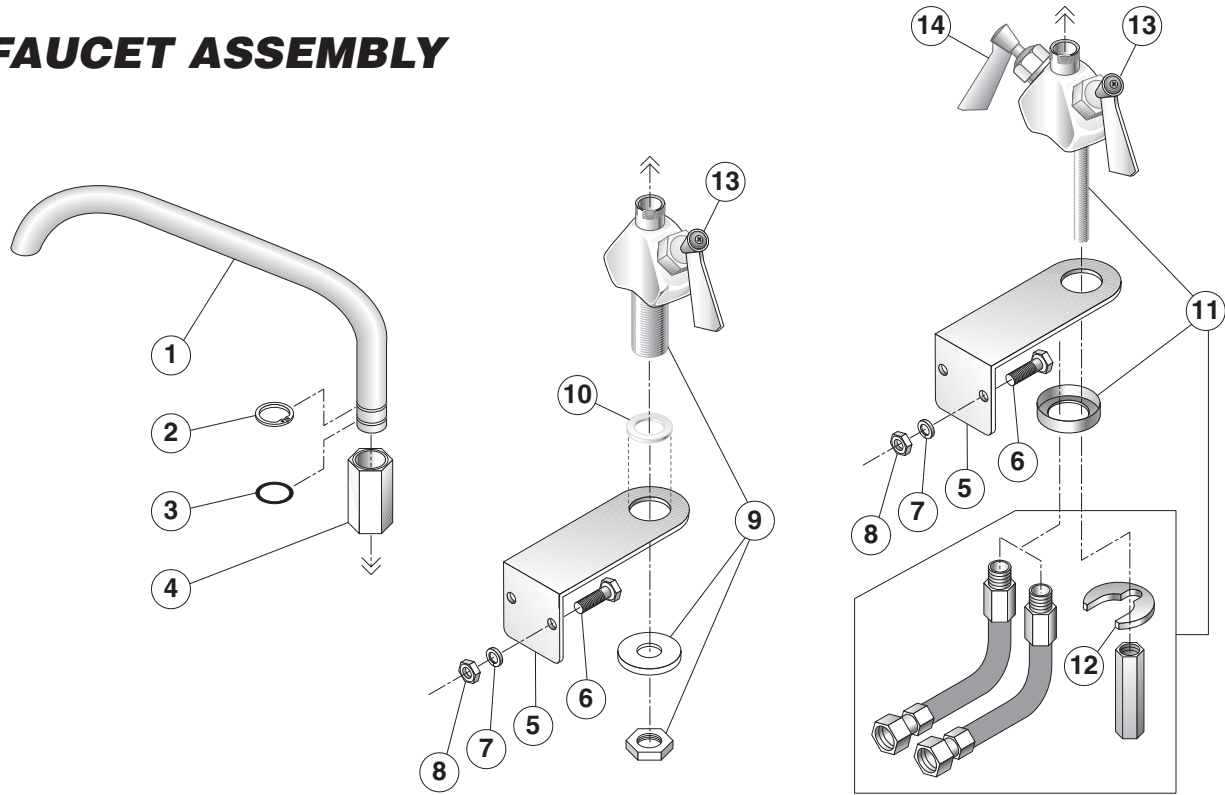

ITEM #	PART #	DESCRIPTION	QTY.
	SPK2	SINGLE PANTRY FAUCET (includes items 1-10)	
	DPK2	DOUBLE PANTRY FAUCET (includes items 1-8 & 11)	
1.	KE50825-2	3/4" SPOUT	1
2.	FA95007-10	RETAINING RING	1
3.	FA05002-19	"O" RING	1
4.	KE51736	LONG FAUCET NUT	1
5.	KE54159	FAUCET MOUNTING BRACKET	1
6.	FA11258	HEX CAP SCREW	2
7.	FA31029	LOCK WASHER	2
8.	FA31029	HEX NUT	2
9.	KE51401	SINGLE PANTRY BODY (c/w item 12)	1
10.	KE50335	ADAPTER WASHER	1
11.	KE51403	DOUBLE PANTRY BODY (c/w item 12 & 13)	1
12.	SE50447	REPLACEMENT HORSESHOE WASHER	1
13.	SE50021	REPLACEMENT STEM ASSEMBLY, COLD WATER	1
14.	SE50020	REPLACEMENT STEM ASSEMBLY, HOT WATER	1

MAIN COMPONENTS

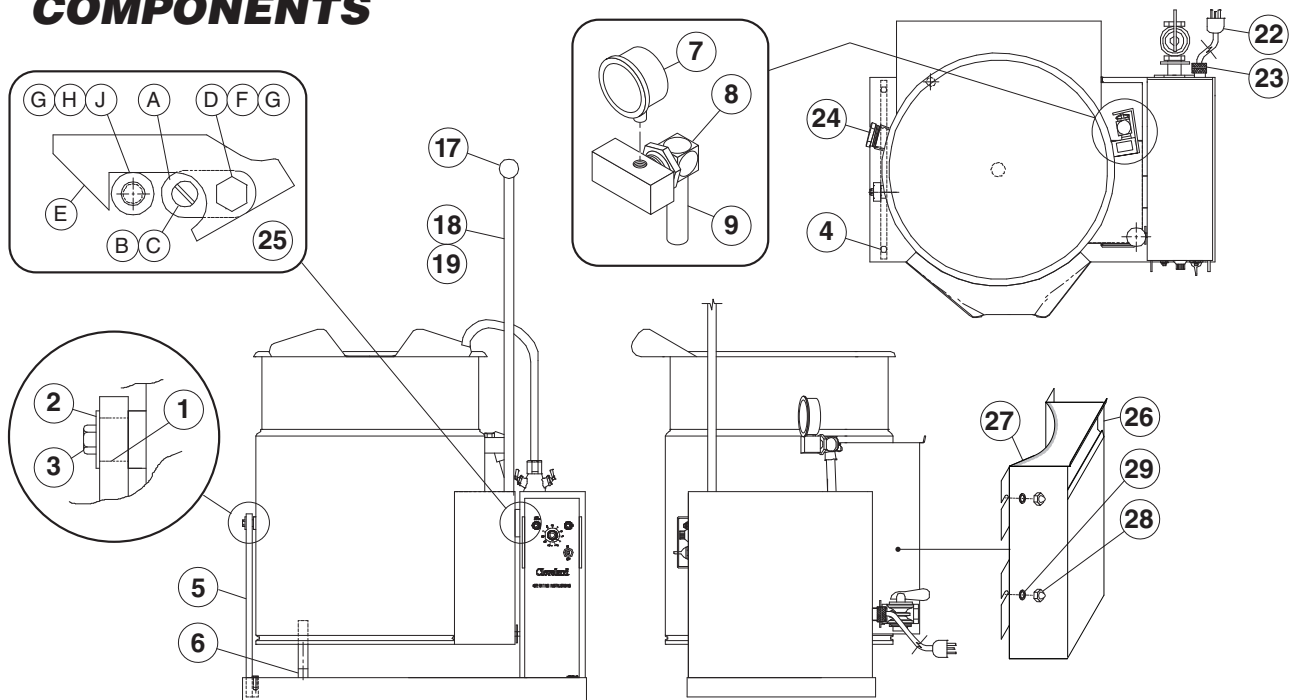

ITEM #	PART #	DESCRIPTION	QTY.
1.	SK50403	BRONZE BEARING	1
2.	SK50434	WASHER	1
3.	FA95081-3	BOLT, MODIFIED	1
4.	FA11258	HEX BOLT, 14-20X3/4" LG.	2
5.	KE02004-2	TRUNNION SUPPORT BAR AND BRACE ASSEMBLY (KGT6/12T)	1
6.	KE50474	FOOT	1
7.	KE50429-5	PRESSURE GAUGE	1
8.	KE54941-5	SAFETY VALVE, 50 PSI, 1/2" (NORTH AMERICA)	1
9.	KE50997	BLOW DOWN TUBE	1
17.	KE50151-2	KNOB	1
18.	KE54670-4	HANDLE, 6 GALLON	1
	KE54670-5	HANDLE, 12 GALLON	1
19.	FA30501-1	FIBER WASHER FOR HANDLE	1
22.	KE54821-8	ELECTRICAL CORD	1
23.	KE54721-2	CORD CONNECTOR	1
24.	KE54468	WATER LEVEL SIGHT GLASS	1
25.	KE003672	MARINE LOCK ASSEMBLY	1
	A	SPACER	1
	B	SCREW, 10-30X1/2"	1
	C	LOCKWASHER, #10	1
	D	HEX NUT, 10-30	1
	E	LATCH	1
	F	SPLIT LOCKWASHER, 1/4"	1
	G	HEX NUT 1/4"-20	2
	H	PIN	1
	J	TOOTH LOCKWASHER, 1/4"	1
26.	KE01914	FLUE (KGT6T)	1
	KE01914-1	FLUE (KGT12T)	1
27.	KE54419-6	GASKET, KGT6T	1
	KE54419-7	GASKET, KGT6/12T	1
28.	FA21051-2	ACCORN NUT. 1/4-20	4
29.	FA30505-1	FLAT WASHER	4

GAS VALVE ASSEMBLY

COMPLETE ASSEMBLIES

PART #	GAS TYPE	FOR UNITS
KE02366-1	NATURAL	KGT6/12T
KE02366-2	NATURAL	KGT12TGB (gearbox option)
KE02366-3	PROPANE	KGT6/12T
KE02366-4	PROPANE	KGT12TGB

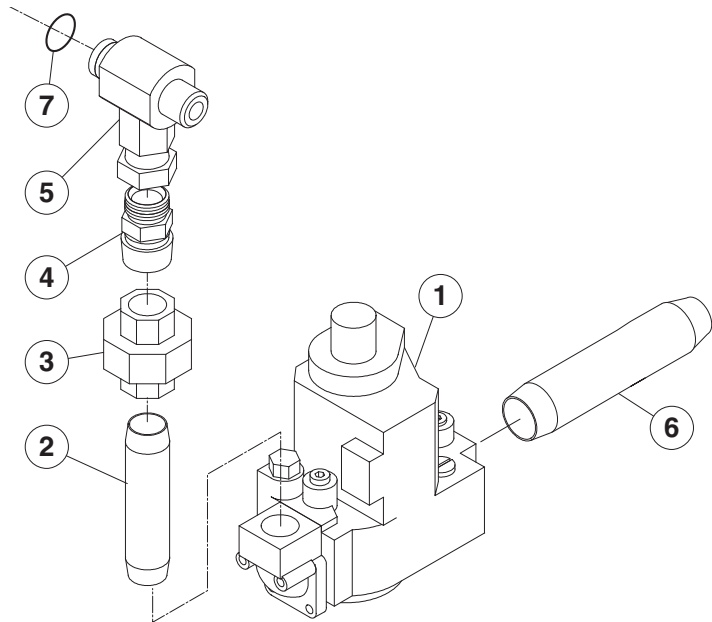

ITEM #	PART #	DESCRIPTION	QTY.
1.	KE55240-8	GAS VALVE, NATURAL (for conversion to propane gas see GAS VALVE REPLACEMENT KIT)	1
2.	N0440C3.125 N0440C6.25	NIPPLE, 1/2" X 3 1/8" (KGT6/12T) NIPPLE, 1/2" X 6 1/4" (KGT6/12TGB, gearbox option)	1 1
3.	FI00073	1/2" BLACK IRON UNION	1
4.	FI05163-1	ADAPTER, 1/2" NPT	1
5.	FI05222-2	SWIVEL CONNECTOR, TRUNNION	1
6.	N0640A6.188	NIPPLE	1
7.	FI05222-3	"O" RING (c/w item #7)	1

SWITCHES & INDICATORS

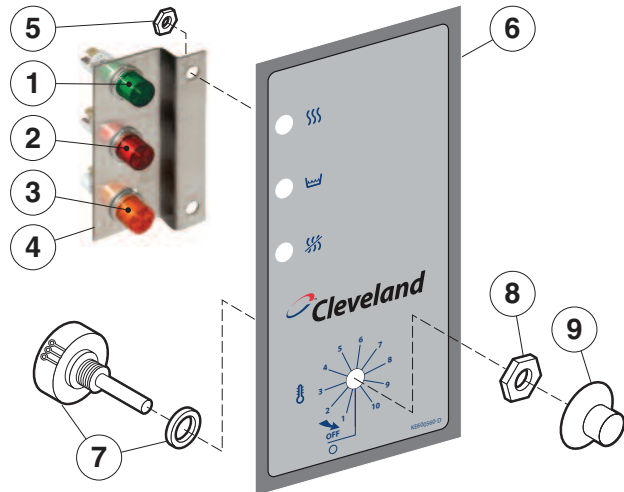

ITEM #	PART #	DESCRIPTION	QTY.
1.	KE55486-3	INDICATOR LIGHT, GREEN	1
2.	KE55486-2	INDICATOR LIGHT, RED	1
3.	KE55486-4	INDICATOR LIGHT, AMBER	1
4.	KE600537	BRACKET, LIGHT	1
5.	FA21006	#10-24, HEX NUT, S.S.	2
6.	KE600560	LABEL	1
7.	SE00114	POTENTIOMETER WITH ON/OFF SWITCH, C/W ITEM #8	1
8.	KE51005	ROTARY SEAL	1
9.	KE50569-1	KNOB, POTENTIOMETER	1

ELECTRICAL COMPONENTS

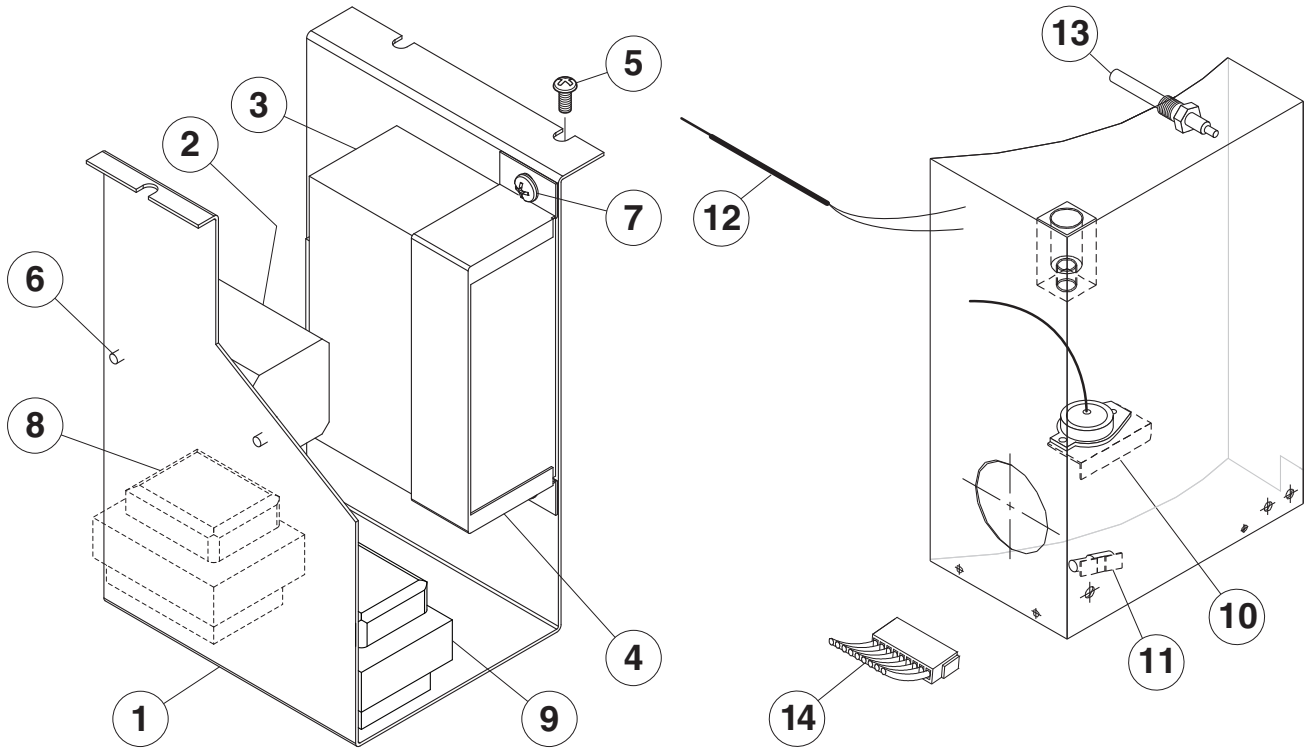

ITEM #	PART #	DESCRIPTION	QTY.
	KE000565-1	COMPONENT ASSEMBLY, 120V (includes items 1-7, 8A & 9A)	1
	KE000565-2	COMPONENT ASSEMBLY, 240V (includes items 1-7, 8B & 9B)	1
1.	KE600545	COMPONENT MOUNTING BRACKET	1
2.	KE50753-7	RELAY	1
3.	KE00458-1	SOLID STATE CONTROL BOX	1
4.	KE50303-1	BLACK BOX BRACKET	1
5.	FA11145	SCREW, #10-32 X 3/8 S.S.	2
6.	FA15018-7	SCREW, ZINC PLATED, #6-32 X 1/4 SEMS HEAD	2
7.	FA11091	MACHINE SCREW, PHILIPS HEAD, #8-32 x 3/8	3
8. A/	KE53838-20	TRANSFORMER, 120/24V OPTION	1
B/	KE53838-18	TRANSFORMER, 240/24V OPTION	1
9. A/	KE53838-27	TRANSFORMER, 120/14V OPTION	1
B/	KE53838-21	TRANSFORMER, 240/16V OPTION	1
10.	KE55069-6	SAFETY THERMOSTAT	1
11.	KE50294-1	MERCURY SWITCH	1
12.	KE00515	THERMISTOR ASSEMBLY	1
13.	KE50556-1	PROBE, LOW WATER	1
14.	WHKGT-2	WIRING HARNESS	1

CONSOLE COMPONENTS

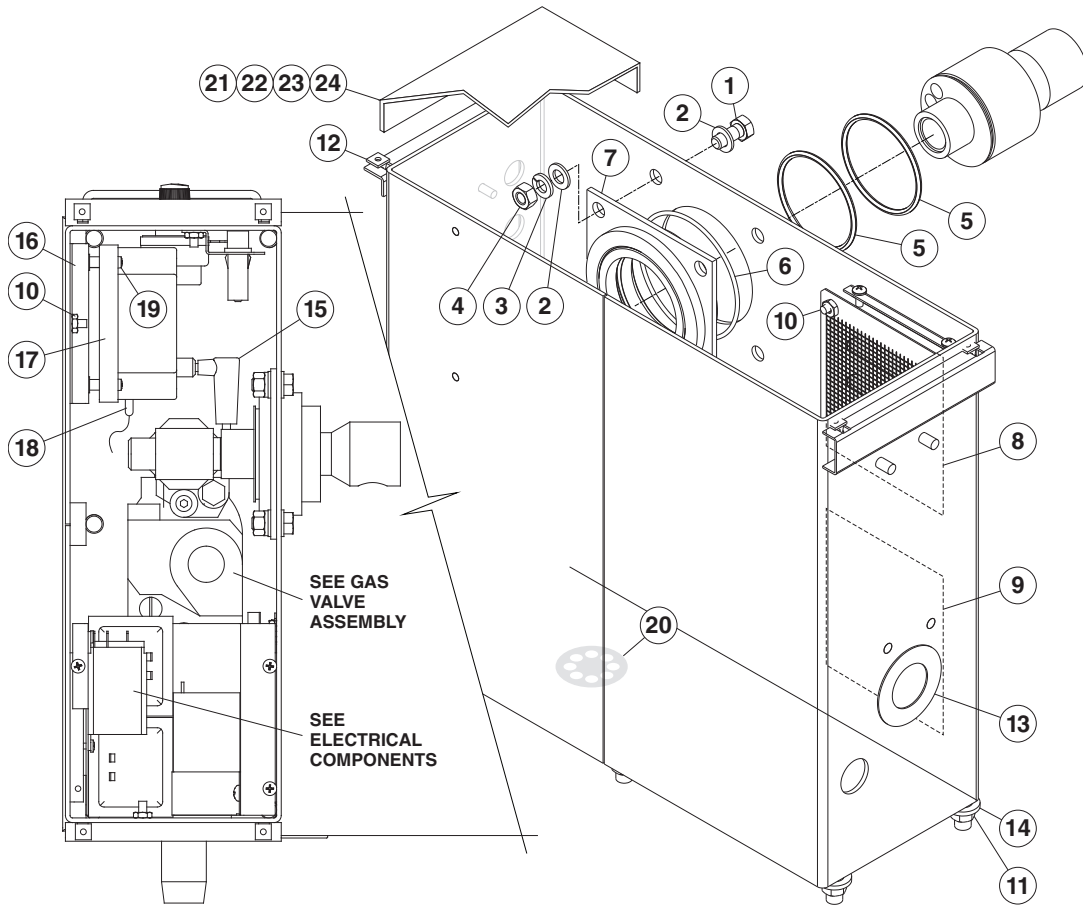

ITEM #	PART #	DESCRIPTION	QTY.
1.	FA11323	SCREW, HEX CAP, 5/16-18 X 3/4	4
2.	KE600343	WASHER, 5/16	8
3.	FA31030	WASHER, SPRING LOCK, 5/16	4
4.	FA21024	HEX NUT, 1/16-18	4
5.	FA05002-45	O-RING, 2 1/4 X 2 1/2	2
6.	FA05002-49	O-RING, 31D X 31 1/16 OD	1
7.	KE01917-1	BEARING SUPPORT WELDMENT	1
8.	KE002948-1	LOUVER PANEL	1
9.	KE002948-2	LOUVER PANEL	1
10.	FA21006	NUT, 10-24	6
11.	FA21026	HEX NUT, 3/8-16	6
12.	FA95074	NYLON ANCORE NUT	4
13.	KE603870	WASHER	1
14.	FA31010	WASHER, SPRING LOCK, 3/8	6
15.	KE54308-3	HIGH VOLTAGE LIGHT ASSEMBLY	1
16.	KE600567	BRACKET, IGNITION MODULE	1
17.	KE53469-2	IGNITION CONTROL MODULE	2
18.	KE54309	LOW VOLTAGE LEAD ASSEMBLY	4
19.	FA15018-8	SCREW, 6-32 X 3/4	4
20.	KE54907-19	PLUG	1
21.	KE003689-1	COVER, (KGT6/12T)	1
	KE003689-2	COVER, (KGT12TGB)	1
22.	KE600284-2	GASKET	1
23.	KE603886	GROUND WIRE	1
24.	FA20504-3	LOCKNUT, 10-24 (K)	1

GAS TRAIN ASSEMBLY

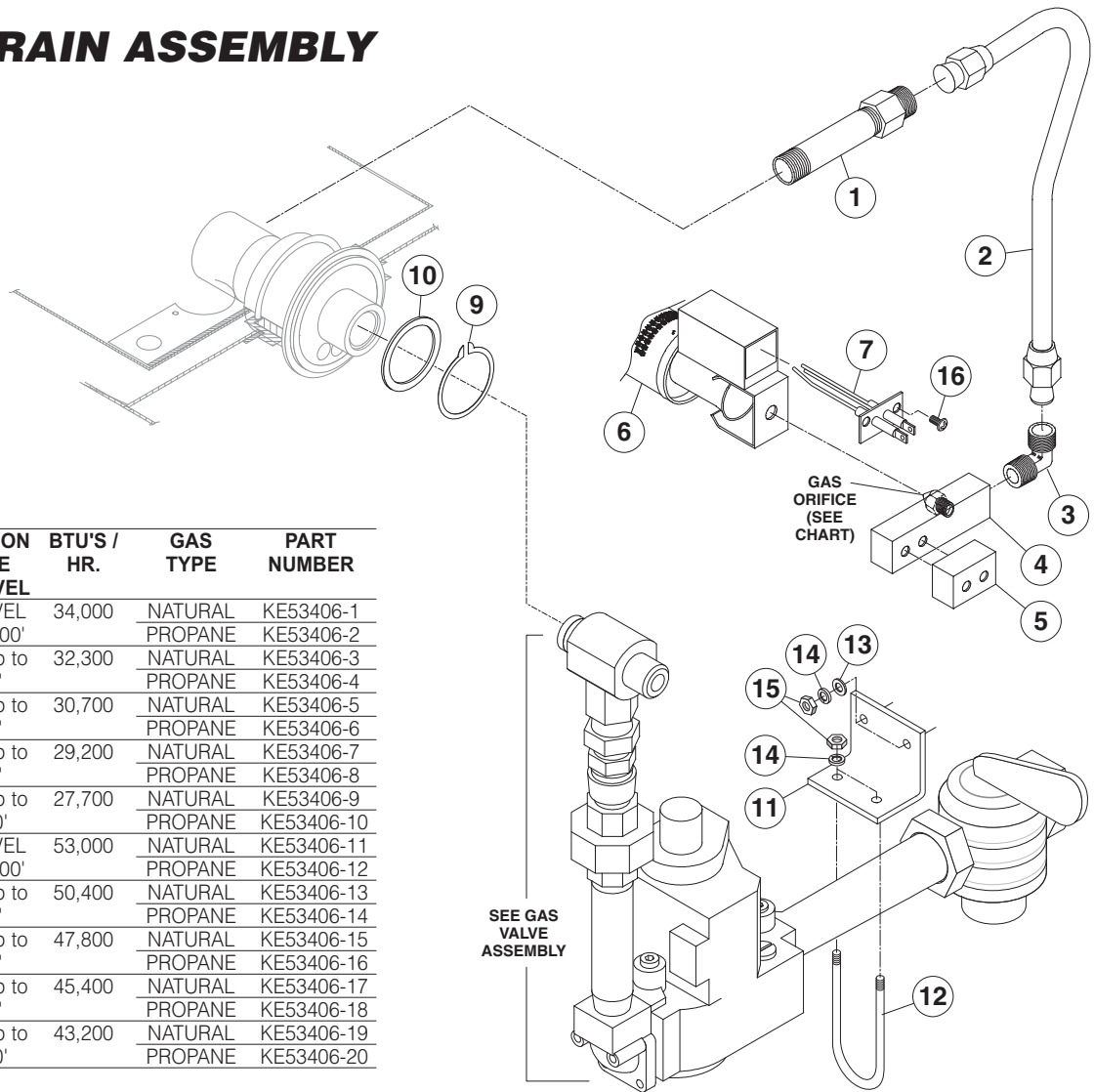

GAS ORIFICES

SIZE	ELEVATION ABOVE SEA LEVEL	BTU'S / HR.	GAS TYPE	PART NUMBER
6 GAL	SEA LEVEL up to 2000'	34,000	NATURAL	KE53406-1
	SEA LEVEL up to 2000'	34,000	PROPANE	KE53406-2
	2,000' up to 4,000'	32,300	NATURAL	KE53406-3
	2,000' up to 4,000'	32,300	PROPANE	KE53406-4
	4,000' up to 6,000'	30,700	NATURAL	KE53406-5
	4,000' up to 6,000'	30,700	PROPANE	KE53406-6
	6,000' up to 8,000'	29,200	NATURAL	KE53406-7
	6,000' up to 8,000'	29,200	PROPANE	KE53406-8
	8,000' up to 10,000'	27,700	NATURAL	KE53406-9
	8,000' up to 10,000'	27,700	PROPANE	KE53406-10
12 GAL	SEA LEVEL up to 2000'	53,000	NATURAL	KE53406-11
	SEA LEVEL up to 2000'	53,000	PROPANE	KE53406-12
	2,000' up to 4,000'	50,400	NATURAL	KE53406-13
	2,000' up to 4,000'	50,400	PROPANE	KE53406-14
	4,000' up to 6,000'	47,800	NATURAL	KE53406-15
	4,000' up to 6,000'	47,800	PROPANE	KE53406-16
	6,000' up to 8,000'	45,400	NATURAL	KE53406-17
	6,000' up to 8,000'	45,400	PROPANE	KE53406-18
	8,000' up to 10,000'	43,200	NATURAL	KE53406-19
	8,000' up to 10,000'	43,200	PROPANE	KE53406-20

ITEM #	PART #	DESCRIPTION	QTY.
1.	KE02012-1	COMPRESSION FITTING (STRAIGHT) & NIPPLE ASS'Y	1
2.	KE003084-1	KGT6T	1
	KE003084-2	KGT12T	1
3.	KE603085	COMPRESSION ELBOW	1
4.	KE54666	ORIFICE ADAPTER	1
5.	KE54700	ORIFICE SUPPORT BLOCK (KGT6T)	1
6.	KE01500-3	BURNER ASSEMBLY (KGT6T), C/W IGNITOR	1
	KE01500-8	BURNER ASSEMBLY (KGT12T), C/W IGNITOR	1
7.	KE53437-2	IGNITOR	1
9.	FA95007-11	RETAINING RING	1
10.	KE54434-1	WASHER	1
11.	KE603869	CLAMPING BRACKET	1
12.	FA95092-2	U BOLT, 1/4-20 UNC	1
13.	FA30505-1	FLAT WASHER, 1/4	2
14.	FA31029	LOCK WASHER, 1/4 SS	4
15.	FA21008	HEX NUT, 1/4-20 UNC	4
16.	FA11145	SCREW	2

GEARBOX ASSEMBLIES

(KGT12TGB,
gearbox option only)

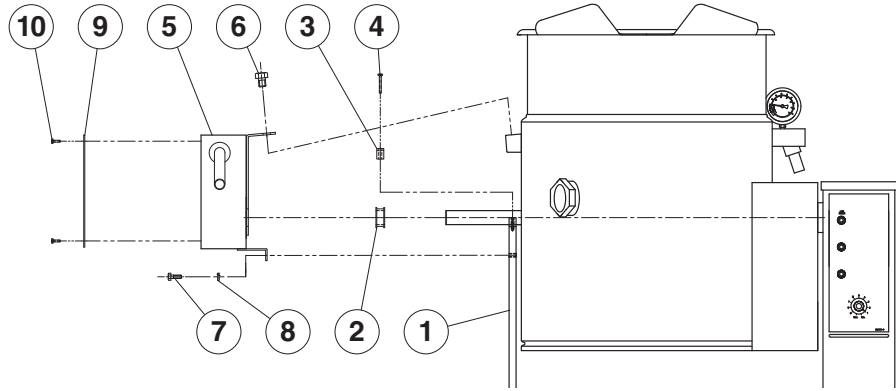

ITEM #	PART #	DESCRIPTION	QTY.
1.	KE02004-3	TRUNNION SUPPORT BAR AND BRACE ASSEMBLY	1
2.	SK50403-2	BEARING, BRONZE	1
3.	KE54656-4	TRUNNION SUPPORT BAR TOP END	1
4.	FA11140	SCREW	2
5.	KE02062-2	TILTING GEARBOX ASSEMBLY	1
6.	KE54732	HEX BOLT, MODIFIED	1
7.	FA11256	HEX BOLT	1
8.	FA31029	LOCKWASHER	1
9.	KE54729-2	GEARBOX COVER	1
10.	FA11145	SCREW	4

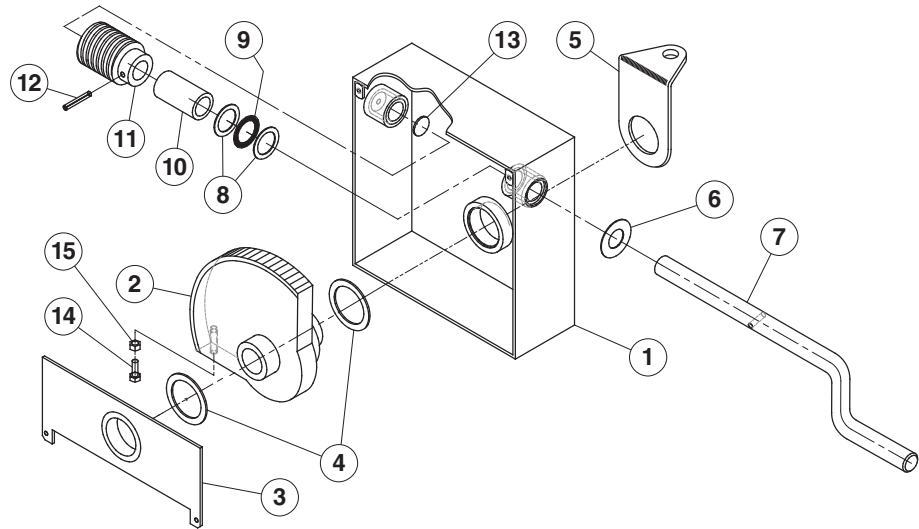

ITEM #	PART #	DESCRIPTION	QTY.
1.	KE02060-1	GEAR BOX WELDMENT	1
2.	KE02059	SPACER GEAR AND SEGMENT ASSEMBLY	1
3.	KE02061	TRUNNION BEARING HOUSING HOLDER ASSEMBLY	1
4.	KE54738-1	BRASS WASHER (TRUNNION SPACER)	2
5.	KE54750-1	TILT BRACKET	1
6.	KE54738-3	WASHER	1
7.	KE50306-1	TUKT SHAFT	1
8.	KE52192	BEARING WASHER	2
9.	KE52191	BEARING	1
10.	KE50426-3	SPACER FOR WORM GEAR	1
11.	KE50315	WORM GEAR	1
12.	FA95005	TENSION PIN	1
13.	KE54737	TILT SHAFT, END SPACER	1
14.	FA10485	HEX BOLT	1
15.	FA20026	HEX NUT	1

Every new piece of Welbilt Foodservice equipment comes with KitchenCare® and you choose the level of service that meets your operational needs from one restaurant to multiple locations

StarCare – Warranty & lifetime service, certified OEM parts, global parts inventory, performance audited

ExtraCare — CareCode, 24/7 Support, online/mobile product information

LifeCare – Install & equipment orientation, planned maintenance, KitchenConnect™, MenuConnect®

Talk with KitchenCare® • 1-844-724-CARE • www.mtwkitchencare.com



To learn how Welbilt Foodservice and its leading brands can equip you, visit our global web site at www.welbilt.com, then discover the regional or local resources available to you.