

### DuraPan™ SERIES

ELECTRIC, OPEN OR MODULAR BASE,  
30 & 40 GALLON (115 & 150 LITER)

**MODELS:**  SEL-30-TR  SEM-30-TR  
 SEL-40-TR  SEM-40-TR

#### Cleveland Standard Features

- Leg or Modular Base
- Full 30/40 Gallon (115/150 Liters) Capacity Rating to Bottom of Pouring Lip
- Power Tilt (Hydraulic Hand Tilt Optional)
- Stainless Steel Clad 5/8" Cooking Surface Guaranteed against warpage
- Stainless Steel Coved Cornered Pans with both Gallon and Liter Markings
- Space-Saving Design- No Clearance Required at rear or sides (optional Faucet and Console requires 4 1/2" on one side)
- All Stainless Steel Construction for durability and easy cleaning
- Adjustable, Electronic Thermostat controls temperature from 100°F to 425°F
- High Efficiency Heating System with even heat distribution - 14 kW's for 30 gallon models, 18 kW's for 40 gallon models.
- Fast Heat-Up and Recovery Time-Preheats in 15 minutes, full capacity from cold to boiling in 60 minutes
- Spring Assist Cover with Adjustable Vent and Full Width Handle
- On/Off Switch, Thermostat Knob and Pilots, recessed to avoid breakage
- Four Stainless Steel, Level adjustable feet, rear flanged for bolting
- Serviceable from the front of the unit
- Two Pilot Lights; Green = Power on, Amber = Temperature Cycling
- Splash Proof Controls and Water Tight Electrical Connections
- High Limit Safety Device set at 450°F (232°C)
- Anti-Splash Pouring Lip
- Typical approvals include UL, CSA, CE and NSF

#### Options & Accessories

- Sliding Drain Drawer with Splash Screen (SLD) (for SEL models only)
- Hydraulic Hand Tilt with quick lowering feature (HTS)
- Power Tilt with Hand Tilt Override (PT1)
- Double or Single Pantry Faucet (SPS14, DPS14), includes Faucet Mounting Bracket
- Double or Single Pantry Skillet Filler with 60" hose (SKF-S or DKF-S)



Open base model shown with optional Drain Drawer (SLD) and Power Tilt (PT1)

#### Short Form Specifications

Shall be CLEVELAND, Tilting Skillet; Model SE - \_\_\_\_ - TR \_\_\_\_ KW, \_\_\_\_ Volts holding no less than \_\_\_\_ gallons ( \_\_\_\_ liters); Complete with thermostatic and Safety Controls; Gallon Markings; Stainless Steel Clad; 5/8" Cooking Surface; Power Tilt; Spring Assist Cover with adjustable Vent. All Stainless Steel Construction. No Clearances Required.

- Hot & Cold Water Pre-Rinse Spray Head with Hose (PRS-S)
- Voltage Options:
  - VOSK1, 240 Volt, 60 Hz, 3 Phase
  - VOSK2, 380/415 Volt, 50 Hz, 3 Phase - for export
  - VOSK3, 440/480 Volt, 60 Hz, 3 Phase
- Food Strainers for pouring spout (FS)
- Vegetable Steamers (VS)
- Poaching Pans (PP)
- Wall Mounting (WMS)
- In-Wall Carriers (IWCS)
- Pan Carriers (PCS), not available on 30 gallon models with a Tangent Draw-Off Valve
- 2" Tangent Draw-Off Valve (TD2), left side only

SECT. XII PAGE 5  
0707

**DIMENSIONS**

MODEL	A	B	C	D	E	F
SEL-30-TR	36"	32"	9"	5"	20"	3"
	(915mm)	(812mm)	(229mm)	(127mm)	(508mm)	(76mm)
SEL-40-TR	48"	44"	12 1/8"	8"	22"	6"
	(1220mm)	(1118mm)	(308mm)	(203mm)	(559mm)	(153mm)

**CAPACITIES**

In 4 oz. servings. Other sizes may be calculated.  
 30 gallons / 115 Liters ..... 960  
 40 gallons / 150 Liters ..... 1280

**SPECIFICATIONS**

CLEARANCE	APPROX. SHIPPING WEIGHTS
<b>RIGHT:</b> 1" (26mm) (4 1/2"/115mm with Faucet)	<b>SEL-30-TR</b> 420 LBS. 191 KG.
<b>LEFT:</b> 1" (26mm)	
<b>REAR:</b> 1" (26mm)	<b>SEL-40-TR</b> 490 LBS. 223 KG

**ELECTRICAL**

SEL-30-TR & SEM-30-TR (Standard Wattage)						
Volts	Ph	Hz	Total Watts	Amps	Wire Size	
208	1	60	14400	69.2	4	
208	3	60	14400	40	8	
240	1	60	14400	60	6	
240	3	60	14400	34.6	8	
380	1	50	14400	37.9	8	
380	3	50	14400	21.9	10	
416	1	50	14400	34.6	8	
416	3	50	14400	20	10	
480	1	60	14400	30	8	
480	3	60	14400	17.3	10	

SEL-40-TR & SEM-40-TR (Standard Wattage)						
Volts	Ph	Hz	Total Watts	Amps	Wire Size	
208	1	60	18000	86.5	3	
208	3	60	18000	50	6	
240	1	60	18000	75	4	
240	3	60	18000	43.4	8	
380	1	50	18000	47.3	6	
380	3	50	18000	27.3	10	
416	1	50	18000	43.3	6	
416	3	50	18000	25	10	
480	1	60	18000	37.5	6	
480	3	60	18000	21.7	10	



EXTERIOR HINGES (REQUIRED FOR OPTIONAL TD 2)

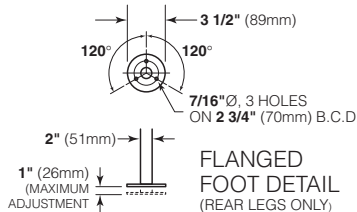
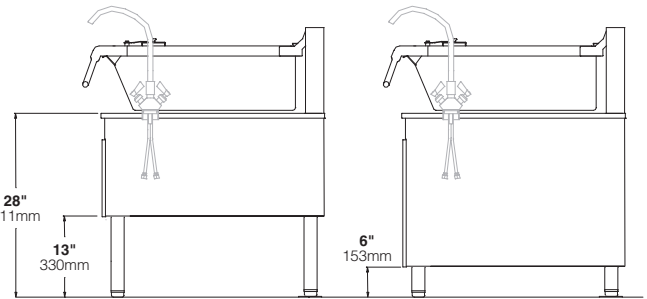
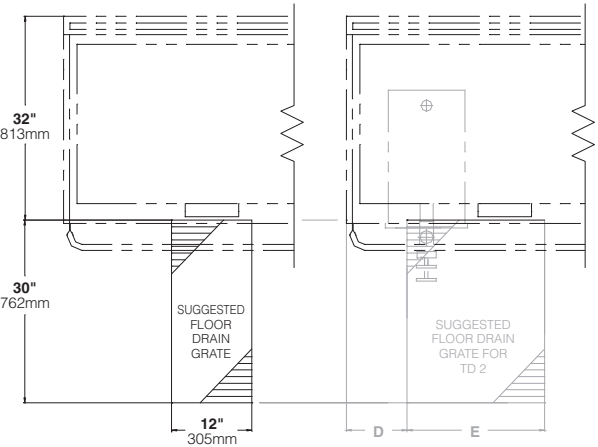

FLANGED FOOT DETAIL (REAR LEGS ONLY)

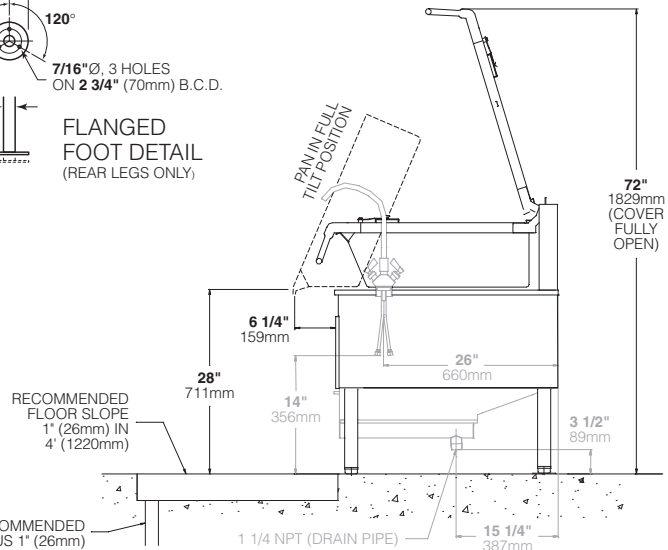
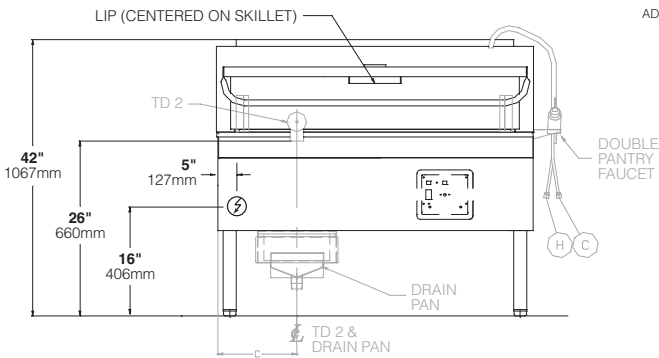
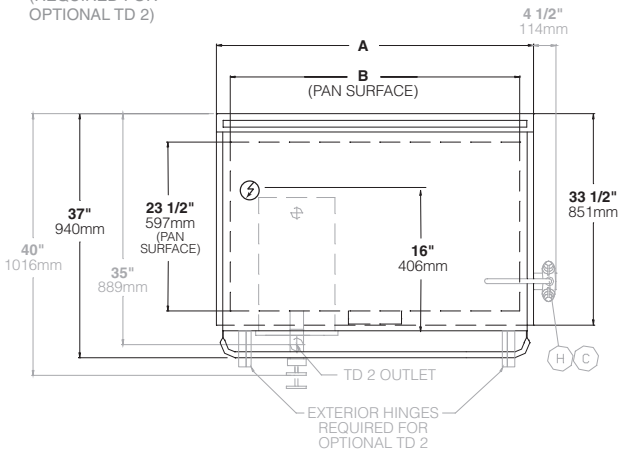

**NOTE:** NON STANDARD ITEMS ARE SHOWN IN GRAY

**NOTES:**

Cleveland Range reserves right of design improvement or modification, as warranted. Many regional, state and local codes exist and it is the responsibility of the owner and installer to comply with the codes. Cleveland Range equipment is built to comply with applicable standards for manufacturers. Included among those approval agencies are U.L., NSF, CGA, CSA, ETL and others.